

# PRECIPITATION RATES AND SPRINKLER IRRIGATION

## *Instructor's Manual*

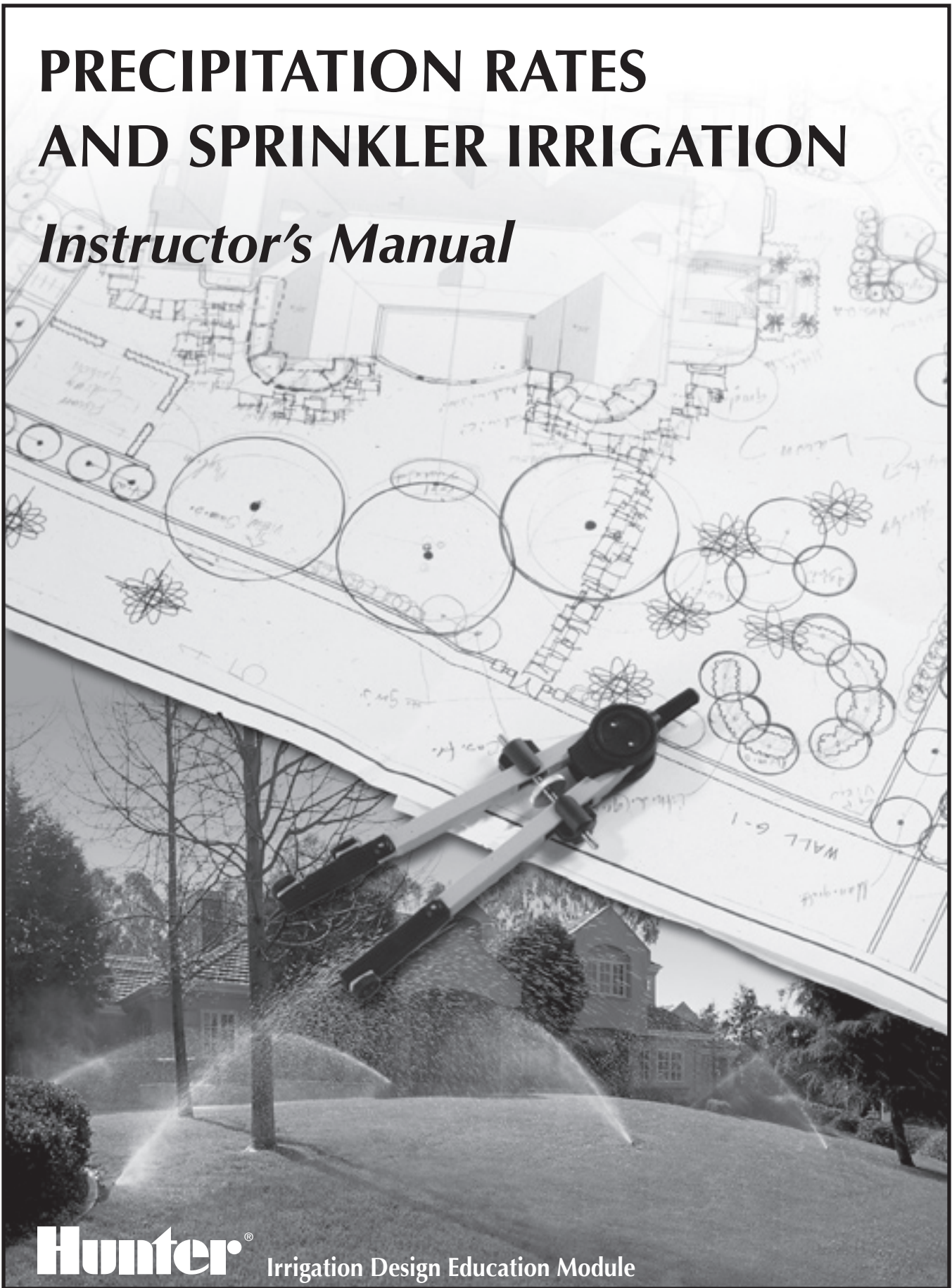



## Notes to the Instructor

---

With the exception of the instructional notes found in sidebars on some of these pages, this manual is identical to the Student's Manual. This allows you to make references to the material by page number. While the information in the sidebars provides you with additional background and recommendations on presentation of the material, the sidebars are not intended to be a part of the presentation.

### Presentation Levels and Estimated Presentation Time

This manual is designed to facilitate presentations to groups ranging from novices to students with advanced knowledge of irrigation systems. We recommend selection of one of the following three levels of presentation, depending on the audience and time available:

**Level I** This level is introductory and spans pages one through five, and the first half of page six. Topics include Introduction, Preliminary Quiz, What Is Precipitation Rate, Sprinkler Type and Expected Precipitation Rate, Sprinkler Versus System Precipitation Rate, Use of Precipitation Rates in Landscape Irrigation, Sprinkler System Costs and Precipitation Rates, and a summary of these topics as the closing remarks (the summary is on page 29).

An estimate of the time necessary for this presentation is 25 to 40 minutes.

**Level II** This presentation includes more advanced topics and concepts. It includes Level I plus the following topics: Determining Precipitation Rate, Effect of Sprinkler Flow Rate on Precipitation Rate, Effect of Head and Row Spacing on Precipitation Rates, Effect of Radius Adjustment on Precipitation Rate and Distribution Uniformity, Matched Precipitation Rates, Proper Use of Matched Precipitation-Rate Heads, The Dry Spot Drives the System, Matched Precipitation Rates Using Multiple Nozzle Selections, Selecting Nozzles for Odd Arcs, and a summary of these topics as the closing remarks.

The estimated presentation time for Level II is one hour to one hour and 15 minutes. The Level II presentation does **not** allow time for students to work through problems as a part of the presentation.

This level requires more time but not necessarily a more advanced audience. The selection of Level I versus Level II should depend on the perceived interest level of the audience. If you believe the audience desires only a brief introduction to precipitation rates, then Level I would be most appropriate. For those audiences wanting more in-depth information, Level II is a better choice provided sufficient time is available.

**Level III** With this presentation, the students will retain the maximum amount of information and it is recommended if time permits. Level III consists of the material presented in Level I and Level II, and includes time for students to practice the precipitation-rate problems in the manual. (Students should work these problems in groups or with someone sitting next to them.)

The estimated time required to present Level III is two to two and one-half hours.

We recognize that sufficient time is not always available to accomplish as much as you might like, and we caution instructors against trying to cover more material than the students can realistically retain in the time available.

## **Cooperative Learning**

Throughout these learning modules we will stress ways in which you can engage the students in active participation. Research has proven that student participation (known as cooperative or collaborative learning) will result in greater retention and understanding of the material than is possible with lecture-style presentations.

A lecture presentation is the most comfortable style for most teachers; therefore, the temptation to present all material in the lecture format is difficult to resist. Until you have used the active-participation techniques we suggest here several times, they may feel awkward. However, we encourage you to persevere and experiment with these techniques, as they will result in increased retention of this or other material.

## Presentation Materials

As part of your presentation, consider including the following materials and supporting items:

1. Calculators – if you intend to make a Level III presentation in which calculations will be practiced in the class, pocket calculators that can be loaned to the students are helpful.
2. Props – for *small* groups, the inclusion of materials for the students to see, touch, and manipulate can be beneficial. For example, you might bring different types of sprinklers such as fixed sprays, bubblers, impact rotors, gear-driven rotors, and micro-sprays. These heads could be used during the portion of the presentation discussing expected precipitation rates, as well as the portion discussing the effect of radius adjustment on precipitation rates.

## Classroom Preparation

Even seasoned instructors can find themselves in less-than-desirable classrooms. If at all possible, check the classroom prior to the presentation so that problems can be corrected.

The most common problem with a classroom is the inability to darken the room sufficiently to show slides or use an overhead projector. If you intend to use the available slide set, additional personal slides, or overhead transparencies, it is very important that the classroom can be darkened. Even minimal light can diminish a good slide presentation.

Another concern is the availability of seating with tables or desks for writing. Desks or tables are recommended as they facilitate note taking and calculation of problems.

## Dividing the Participants Into Groups

We recommend that the students be divided into small work groups; each group should consist of two to four members—three is ideal. These groups should be established in the fashion you deem most appropriate. For groups of 30 or less, some possible methods include the following:

1. Divide the participants into groups of three.
2. Have the participants count off into groups of three.
3. Preselect the groups to achieve heterogeneous groups (usually used when the number of participants is small and you already know the individuals).

With groups of more than 30 people, ask the participants to team up with two other people.

Work groups are helpful in all presentation levels (particularly for the preliminary quiz) but they are essential for a Level III presentation (working sample problems).

## Table of Contents

Introduction.....	1
<i>Important Facts to Learn</i> .....	1
What Is “Precipitation Rate?” .....	1
<i>Are All Precipitation Rates the Same?</i> .....	2
Sprinkler Type and Expected Precipitation Rate .....	2
<i>High Precipitation Rates – More than 1.0 in./hr</i> .....	2
<i>Moderate Precipitation Rates – Between 0.5 and 1.0 in./hr</i> .....	2
<i>Low-Precipitation Rates – 0.5 in./hr or Less</i> .....	3
“Sprinkler” Precipitation Rates Versus “System” Precipitation Rates..	3
<i>Sprinkler Precipitation Rates</i> .....	3
<i>System Precipitation Rates</i> .....	3
Use of Precipitation Rates in Landscape Irrigation .....	4
<i>Sprinkler Head Selection</i> .....	4
<i>Scheduling Sprinkler Run Time</i> .....	4
Sprinkler System Cost and Precipitation Rates .....	6
Determining Precipitation Rates .....	6
<i>The Sprinkler Spacing Method</i> .....	6
<i>Sample Problems for the Sprinkler Spacing Method</i> .....	10
<i>The Total Area Method</i> .....	11
<i>Sample Problems for the Total Area Method</i> .....	12
Effect of Sprinkler Flow Rate on Precipitation Rate .....	13
Effect of Head and Row Spacing on Precipitation Rates.....	14
Effect of Radius Adjustment on Precipitation Rate and Distribution Uniformity .....	15
<i>Reducing the Radius</i> .....	17
<i>Increasing the Radius</i> .....	17
<i>Summary of Effect of Radius Adjustment on     Precipitation Rate</i> .....	17
<i>Sample Problems: Precipitation Rate Versus Flow,     Head/Row Spacing, and Radius Adjustment</i> .....	18
Matched Precipitation Rates .....	19
<i>Achieving Matched Precipitation Rates</i> .....	19
<i>A System Without Matched Precipitation Rates</i> .....	21
<i>Sample Problems: Identifying Matched     Precipitation-Rate Heads</i> .....	22
Proper Use of Matched Precipitation-Rate Heads .....	23
<i>The Dry Spot Drives the System</i> .....	24
<i>Matched Precipitation Rates Using Multiple Nozzle Selections</i> ...	25
<i>Performance Data PGP Standard Nozzles –     25 Degree Trajectory</i> .....	26
Selecting Nozzles for Odd-Arc Heads .....	27
<i>Sample Problems: Selecting Nozzles for Matched     Precipitation Rates</i> .....	28
Summary .....	29
Answers to Sample Problems .....	30
Calculating Precipitation Rate Formulas .....	33



## Introduction

---

Today's irrigation designer or system manager faces a multitude of concerns including:

- increased costs for water
- excessive runoff
- wet spots that do not allow use of a turf or landscape
- dry spots that are unsightly or cause lost plant material
- increased pests and diseases
- higher bills for pumping
- too much or too little water applied

Each of these can be related to precipitation rates; thus, understanding precipitation rates can help you avoid these common problems, leading to improved landscapes and reduced costs through better irrigation design and management.

## Important Facts to Learn

The purpose of this booklet is to provide an understanding of sprinkler precipitation rates and the importance of matching precipitation rates. After you have read through this material, you should be able to:

1. Define *Precipitation Rate*.<sup>1</sup>
2. Give two reasons why precipitation rates are important in landscape irrigation.
3. Calculate precipitation rates using both standard formulas and the Hunter Precipitation Rate Estimator.
4. Select matched precipitation-rate heads and nozzle combinations from a manufacturer's specifications.

## What Is "Precipitation Rate?"

---

If someone said they were caught in a rainstorm that dropped one inch of water in an hour you would have some idea of how "hard" or "heavily" the rain came down. A rainstorm that covers an area with one inch of water in one hour has a "precipitation rate" of one inch per hour (1 in./hr). Similarly, if a sprinkler system applies enough water to cover the irrigated area with one inch of water in one hour, the sprinkler system also has a precipitation rate of 1 in./hr. Thus, the precipitation rate is the speed at which a sprinkler or an irrigation system applies water.

**Note:** Precipitation rates in the United States are measured in inches per hour (in./hr), and elsewhere in millimeters per hour, written as mm/hr (25.4 mm/hr = 1 in./hr).

---

The presentation should begin with a preliminary test to assess the knowledge level of the students. This will help you determine the level at which the material should be presented.

## Preliminary Quiz

---

With the other members of your group, take two minutes to determine a definition of **Precipitation Rate**. At the end of two minutes, I will ask for definitions from various groups.

---

At the end of the two minutes, ask for volunteers to give their definitions. Reword the definitions given, or continue to ask for examples, until you have a definition that closely matches one of these.

### **Precipitation Rate:**

1. How fast water is applied, as measured in inches per hour (in./hr).
  2. An amount of water applied over a period of time, usually measured in inches per hour.
- 

<sup>1</sup>The term "application rate" can be used interchangeably with "precipitation rate."

## Are All Precipitation Rates the Same?

Landscape irrigation systems and individual sprinklers themselves have widely varying precipitation rates. The rates typically vary from:

- Low – 0.5 in./hr and below
- Medium – 0.5 to 1.0 in./hr
- High – 1.0 in./hr and above

These precipitation rates reflect the typical soil infiltration<sup>2</sup> rates. Use of sprinklers with high precipitation rates on soils with low infiltration rates would result in excessive runoff.

## Sprinkler Type and Expected Precipitation Rate

While the correlation between sprinkler type and precipitation rate is not absolute, the following chart provides a general indication of the precipitation rates you can expect with different types of sprinkler heads.

**TYPICAL PRECIPITATION RATE RANGES**

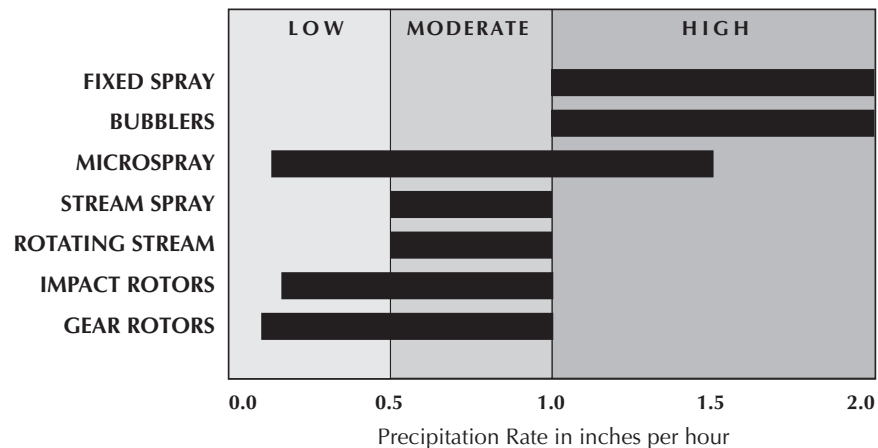

### High Precipitation Rates – More than 1.0 in./hr

Sprinklers with these precipitation rates would be best suited for use on level, coarse-textured soils with high infiltration rates and little hazard of erosion. If used in other conditions they must be operated in short cycles to avoid excessive runoff and soil erosion.

### Moderate Precipitation Rates – Between 0.5 and 1.0 in./hr

Sprinklers with these precipitation rates should be used under conditions similar to those described for high precipitation-rate sprinklers. However, these could be operated for somewhat longer cycles than the high precipitation-rate heads.

<sup>2</sup> The term “intake rate” can be used interchangeably with “infiltration rate.”

## Low-Precipitation Rates – 0.5 in./hr or Less

Low precipitation-rate sprinklers have the advantage in that they can be used with a wider variety of slope and soil textures without excessive runoff or soil erosion.

## “Sprinkler” Precipitation Rates Versus “System” Precipitation Rates

---

Depending on the construction of the irrigation system, the precipitation rate quoted may be either a “sprinkler” or a “system” rate.

### Sprinkler Precipitation Rates

When the precipitation rate for a “sprinkler” is given, it refers to the rate for a system in which only one specific type of head is used. The precipitation rate for a single sprinkler is calculated using the **Sprinkler Spacing Method**. This method calculates the precipitation rate for those sprinkler heads with the same spacing, rate of flow (in gallons per minute, or GPM) and arc of spray.

### System Precipitation Rates

The precipitation rate for a “system” is the average precipitation rate of all sprinklers in an area regardless of the arc, spacing, or flow rate for each head. The system precipitation rate is calculated using the **Total Area Method**. The area for which the calculation is made usually corresponds to all the heads on one irrigation control valve. While individual heads in an area may have different precipitation rates, this method gives you an *average* over the entire area.

The Total Area Method is most useful and accurate when all the heads in the area have similar precipitation rates. Where the precipitation rates of the sprinkler heads vary considerably, the average precipitation rate can be misleading. Where there are differences in precipitation rates, the irrigation system may have applied enough water to the “average” area, but there very likely will be dry spots and wet spots as well.

**Note:** It is important to remember that precipitation rates and system uniformity are two completely separate issues. Calculated precipitation rates do not reflect how uniformly the water is being applied. System uniformity is an important calculation and should always be taken into account when scheduling irrigation systems or determining minimum water supply requirements.

# Use of Precipitation Rates in Landscape Irrigation

Precipitation rate is critical to selection of sprinkler heads for a system and scheduling sprinkler run times.

## Definitions

**Infiltration Rate** – How quickly water moves into the soil. A higher infiltration rate allows a higher precipitation rate without runoff.

**Texture** – The relative proportions of sand, silt and clay in a given soil. The students may relate to an analogy of relative size between soil particles: sand, silt and clay having the same relative proportions as boulders, marbles and BBs. Types of soil texture include sandy loam, sandy clay, loam, clay loam, and clay, among others. Generally, sandy loams have higher (faster) infiltration rates than clays.

**Structure** – The combination of various soil particle types into a uniform mixture that behaves as a single unit. Structural classes include granular, blocky, and columnar, among others. A blocky structure generally allows faster infiltration than does a columnar structure.

## Sprinkler Head Selection

When selecting sprinkler heads, it is necessary to limit their precipitation rate to the infiltration rate of the soil. The infiltration rate is affected by the soil texture, soil structure, plant material, and the slope. The following chart gives a relationship between these factors and the infiltration rate of the soil. Failure to limit precipitation rates to the soil infiltration rate can result in excessive runoff and erosion.

SOIL TEXTURE	MAXIMUM PRECIPITATION RATES (inches per hour):							
	0 to 5% slope		5 to 8% slope		8 to 12% slope		12%+ slope	
	Cover	Bare	Cover	Bare	Cover	Bare	Cover	Bare
Coarse sandy soils	2.00	2.00	2.00	1.50	1.50	1.00	1.00	0.50
Coarse sandy soils over compact subsoils	1.75	1.50	1.25	1.00	1.00	0.75	0.75	0.40
Uniform light sandy loams	1.75	1.00	1.25	0.80	1.00	0.60	0.75	0.40
Light sandy loams over compact subsoils	1.25	0.75	1.00	0.50	0.75	0.40	0.50	0.30
Uniform silt loams	1.00	0.50	0.80	0.40	0.60	0.30	0.40	0.20
Silt loams over compact subsoil	0.60	0.30	0.50	0.25	0.40	0.15	0.30	0.10
Heavy clay or clay loam	0.20	0.15	0.15	0.10	0.12	0.08	0.10	0.06

*The maximum precipitation-rate values listed are as suggested by the United States Department of Agriculture. The values are average and may vary with respect to actual soil conditions and condition of the ground cover.*

## Scheduling Sprinkler Run Time

Scheduling sprinkler run times without knowing the precipitation rate is like trying to estimate your arrival time without knowing how fast you are traveling. The precipitation rate represents the speed at which an amount of water is applied. Knowing this is important because it helps us estimate how long it will take to apply the water needed by the plants in the landscape. The precipitation rate is also required for proper irrigation scheduling to prevent dry or wet areas. If the precipitation rate is not known, the tendency is to over water to be sure enough water is applied.

Sometimes there is a misconception about sprinkler run times and precipitation rates. The misconception is that sprinkler systems with low precipitation rates take longer to irrigate the landscape. While it is true that each head must be run for a longer period of time, more heads can be operated at one time and, therefore, the total irrigation time for an entire project will be the same for both high and low precipitation-rate sprinkler heads.

In the following illustration, two areas of the same size, one irrigated with high and one with low precipitation-rate sprinklers, both require the same amount of irrigation time. The water supply is 30 GPM and the plants require 0.25 water.

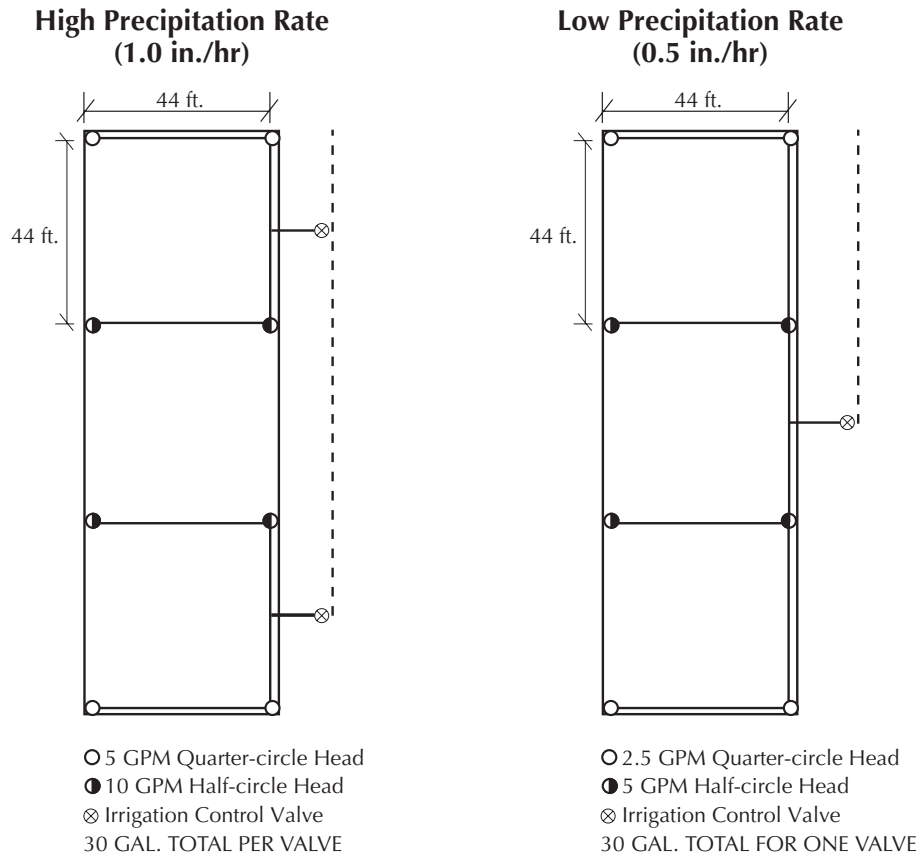

In the high precipitation-rate example, two valves are required and each valve must be operated for 15 minutes in order to apply the 0.25 inches of water needed. Total run time is 30 minutes.

In the low precipitation-rate example, the lower GPM per head allows the entire area to be operated by one control valve. The lower precipitation rate requires that the heads be operated for 30 minutes but since all the heads are operated at the same time the total run time is the same as in the high precipitation-rate example.

With low or high precipitation-rate sprinkler systems, the total run time is limited by the volume (GPM) available from the water source, not the precipitation rate of the sprinkler system.

---

At the end of a **Level I** presentation, ask the students to develop definitions or descriptions for the following without looking in the manual:

- Precipitation rate
  - Sprinkler precipitation rate
  - System precipitation rate
  - Two uses for precipitation rates in landscape irrigation
- 

---

For a **Level II** presentation, avoid calculation of precipitation rates by hand or with a calculator. The presentation time should be used to familiarize the students with the basic formulas. You can assign the sample problems as homework so the students can become familiar with the calculations later. During **Level III** presentations, some calculations can be done during the presentation.

---

## **Sprinkler System Cost and Precipitation Rates**

---

Low precipitation-rate sprinkler systems often cost less to install than those with high precipitation rates. This is because low precipitation-rate sprinklers require lower flow rates (GPM), per acre irrigated, than high precipitation-rate sprinklers. This means fewer valves and controller stations are required per acre, and therefore less cost per acre.

## **Determining Precipitation Rates**

---

As mentioned earlier, there are two primary methods used to determine precipitation rate: the Sprinkler Spacing Method and the Total Area Method.

### **The Sprinkler Spacing Method**

This method is used to determine the precipitation rate for a single sprinkler. The rate is calculated assuming the sprinkler is used in conjunction with other sprinklers of the same kind (i.e., same arc, flow, and spacing). With this method, one can compare the precipitation rate of similar types of sprinkler heads with each other. In the past, this formula was used for the Sprinkler Spacing Method:

$$P_r = \frac{96.25 \times \text{GPM (for } 360^\circ \text{ head)}}{\text{Head Spacing} \times \text{Row Spacing}}$$

where:

**$P_r$**  is the precipitation rate in inches per hour.

**96.25** is a constant that converts gallons per minute to inches per hour. It is derived from 60 min/hr divided by 7.48 gallons per cu ft, multiplied by 12 in. per ft

**GPM** is the rated flow of the full-circle head used in gallons per minute.

**Head Spacing** is the distance in feet between heads in the same row (see the following diagram).

**Row Spacing** is the distance in feet between the rows of sprinklers (see the following diagram).

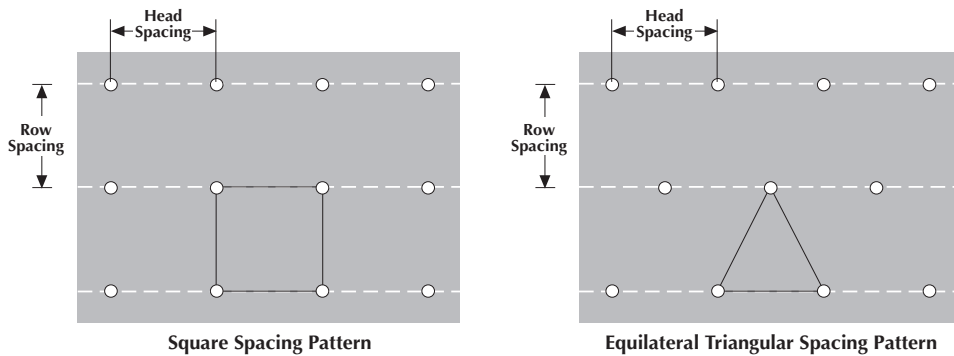

While the previous formula has been in use for many years, it requires an additional calculation for sprinkler heads with spray arcs under 360 degrees. To simplify this process, we have modified the Sprinkler Spacing Method formula to be applicable to heads of any arc. The modified formula, which is now recommended, is:

$$P_r = \frac{34650 \times \text{GPM (for any arc)}}{\text{Degrees of Arc} \times \text{Head Spacing} \times \text{Row Spacing}}$$

where:

$P_r$  is the precipitation rate in inches per hour.

**34650** is a constant that converts gallons per minute to inches per hour for sprinklers with any arc. It is derived from 60 min/hr divided by 7.48 gallons per cu ft, multiplied by 12 in. per ft times 360 degrees. (Note: If the flow of the head is in gallons per hour (GPH), instead of gallons per minute (GPM), the constant should be changed to 577.5).

**GPM** is the rated flow of the head used, regardless of its arc, in gallons per minute.

**Degrees of Arc** is the arc of the spray pattern, in degrees, for the sprinkler selected (e.g., full circle = 360°, half circle = 180°, etc.).

**Head Spacing** is the distance in feet between heads in the same row.

**Row Spacing** is the distance in feet between the rows of sprinklers.

---

The modified formula and the constant **34650** shown here represent an attempt to simplify the formula for calculating precipitation rates for individual sprinklers. By modifying the formula, it is no longer necessary to convert the flow to the equivalent for a full-circle head. This is of particular value with the new sprinklers that have odd arcs rather than the standard 90, 180 and 360 degrees found on sprinkler heads in the past.

---

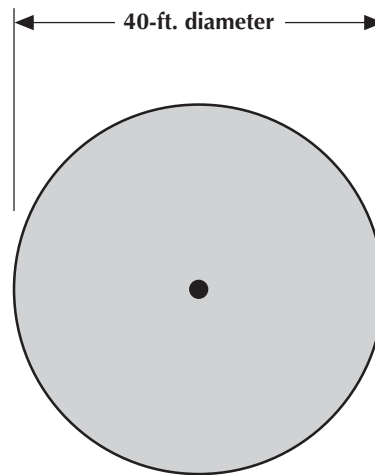

**Full-circle sprinkler at 5 GPM.**

This illustration depicts a full-circle head with a coverage diameter of 40 feet (a 20-ft radius) that delivers 5.0 GPM over that circle. The manufacturer recommends a 20-ft head spacing and 20 feet between the rows of heads (i.e., square spacing).

Using the modified Sprinkler Spacing Method formula, we can determine the precipitation rate as follows:

$$\begin{aligned}
 P_r &= \frac{34650 \times \text{GPM (for any arc)}}{\text{Arc Degrees} \times \text{Head Spacing} \times \text{Row Spacing}} \\
 &= \frac{34650 \times 5.0}{360 \times 20 \times 20} \\
 &= \frac{173250}{144000} \\
 &= 1.20 \text{ in./hr}
 \end{aligned}$$

This formula works equally well for sprinklers of any arc:

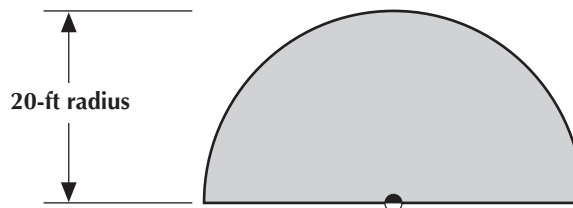

**Half-circle sprinkler at 2.5 GPM.**

In this example, the head selected is a half-circle (180° arc) sprinkler with a 20-ft radius delivering 2.5 GPM. The manufacturer recommends a 20-ft head spacing and 20 feet between the rows of heads (square spacing). Using the modified Sprinkler Spacing Method, we can determine the precipitation rate as follows:

$$\begin{aligned} P_r &= \frac{34650 \times \text{GPM (for any arc)}}{\text{Arc (degrees)} \times \text{Head Spacing} \times \text{Row Spacing}} \\ &= \frac{34650 \times 2.5}{180 \times 20 \times 20} \\ &= \\ &= \frac{86625}{72000} \\ &= 1.20 \text{ in./hr} \end{aligned}$$

Notice the precipitation rate for both the full-circle head and the half-circle head is 1.20 in./hr. This is because the half-circle head covers half the area and applies half the gallonage of the full-circle head.

---

These and the subsequent sample problems should be completed by the students outside of the presentation period. In most cases it is assumed there will not be sufficient time to work on the problems during the presentation. Students should be advised to return to the sample problems for review.

When used as a part of an ongoing irrigation course, these problems could be assigned as homework to be completed prior to the next class session. In these cases, verification of the students' knowledge could be tested by asking various students to review the problems with the group as a whole.

If there is time to do additional problems during the presentation session, students should be instructed to do so with one or two other participants.

Working together in these small groups allows the students to check with others regarding misunderstandings. This process facilitates increased retention of the material.

---

## Sample Problems for the Sprinkler Spacing Method

Use the modified Sprinkler Spacing Method to determine precipitation rate in the following problems (the answers can be found on page 30).

1. The characteristics of the selected head are:
  - full-circle (360° arc) sprinkler
  - 3.5 GPM
  - 30-ft radius
  - recommended head spacing is 30 feet
  - recommended row spacing is 30 feet (square spacing)
2. The characteristics of the selected head are:
  - quarter-circle (90° arc) sprinkler
  - 0.5 GPM
  - 15-ft radius
  - recommended head spacing is 15 feet
  - recommended row spacing is 13 feet (equilateral triangular spacing)
3. The characteristics of the selected head are:
  - three-quarter-circle (270° arc) sprinkler
  - 1.75 GPM
  - 8-ft radius
  - recommended head spacing is 9 feet
  - recommended row spacing is 7.5 feet (triangular spacing)
4. The characteristics of the selected head are:
  - one-third-circle (120° arc) sprinkler
  - 10.5 GPM
  - 60-ft radius
  - recommended head spacing is 50 feet
  - recommended row spacing is 55 feet (rectangular spacing)

## The Total Area Method

This calculation is best suited for determining the average precipitation rate for a system, or portion of a system, that uses sprinklers with differing arcs, flow rates, and spacings. The formula for the Total Area Method is:

$$P_r = \frac{96.25 \times \text{Total GPM}}{\text{Total Area}}$$

where:

$P_r$  is the precipitation rate in inches per hour.

**96.25** is a constant that converts gallons per minute to inches per hour. It is derived from 60 min/hr divided by 7.48 gallons per cu ft times 12 inches per foot.

**Total GPM** is the cumulative flow from all sprinklers in the specified area, in gallons per minute.

**Total Area** is the area irrigated, in square feet.

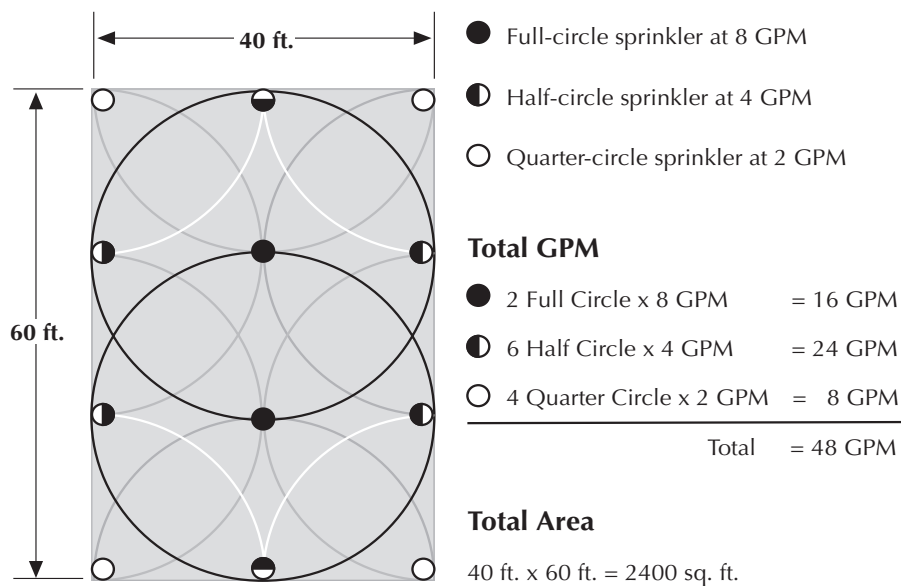

In this illustration, the area under consideration contains 12 sprinkler heads with arcs varying from 90° to 360°, with flow rates between 2 and 8 GPM, totalling of 48 GPM. Using the Total Area Method formula, we can determine the precipitation rate as follows:

$$\begin{aligned}
 P_r &= \frac{96.25 \times \text{Total GPM}}{\text{Total Area}} \\
 &= \frac{96.25 \times 48}{2400} \\
 &= 1.93 \text{ in./hr}
 \end{aligned}$$

## Sample Problems for the Total Area Method

Use the Total Area Method to determine precipitation rate in the following problems (the answers can be found on page 31).

1. The characteristics of the selected area are:
  - total flow to the area is 25 GPM
  - total area irrigated is 2100 square feet
  
2. The characteristics of the selected area are:
  - total flow to the area is 250 GPM
  - total area irrigated is 1 acre (43560 square feet )

## Effect of Sprinkler Flow Rate on Precipitation Rate

The precipitation rate of a sprinkler or a system varies **directly** with the flow rate of the sprinkler (measured in GPM). Because Precipitation Rate is a measurement of how fast water is being applied, if the spacing remains constant, **increasing** sprinkler flow **increases** the precipitation rate and **decreasing** sprinkler flow **decreases** the precipitation rate.

**SPRINKLER FLOW vs. PRECIPITATION RATE**

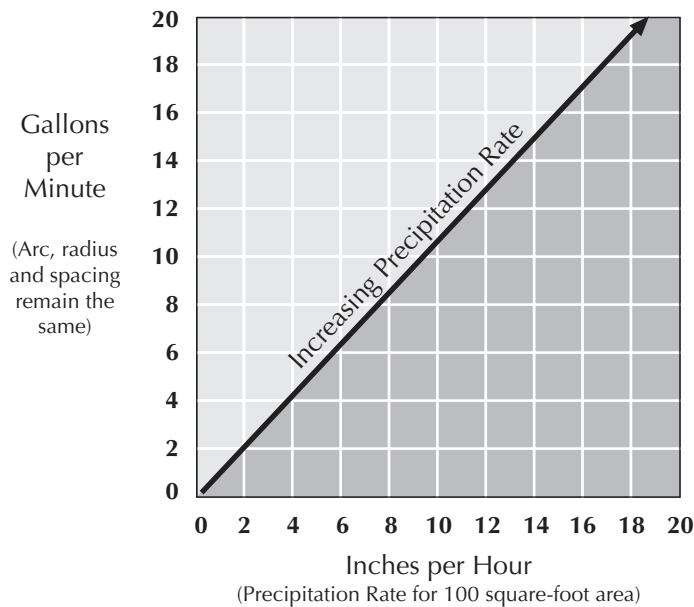

For example, if the sprinkler flow is doubled (by changing the head or nozzle), the precipitation rate will double, as shown by the following calculations.

Precipitation rate for a 180° head at 2.5 GPM spaced on a 20-ft by 20-ft square grid:

$$\begin{aligned}
 P_r &= \frac{34650 \times \text{GPM (for any arc)}}{\text{Arc (degrees)} \times \text{Head Spacing} \times \text{Row Spacing}} \\
 &= \frac{34650 \times 2.5}{180 \times 20 \times 20} \\
 &= \frac{86625}{72000} \\
 &= 1.20 \text{ in./hr}
 \end{aligned}$$

Precipitation rate for a 180° head at 5.0 GPM spaced on a 20-ft by 20-ft square grid:

$$\begin{aligned} P_r &= \frac{34650 \times \text{GPM (for any arc)}}{\text{Arc (degrees)} \times \text{Head Spacing} \times \text{Row Spacing}} \\ &= \frac{34650 \times 5.0}{180 \times 20 \times 20} \\ &= \frac{173250}{72000} \\ &= 2.40 \text{ in./hr} \end{aligned}$$

## Effect of Head and Row Spacing on Precipitation Rates

---

The precipitation rate of a sprinkler or system is inversely related to head spacing and row spacing. With the sprinkler flow remaining constant, **increasing** head or row spacing **decreases** the precipitation rate and, conversely, **reducing** head or row spacing **increases** the precipitation rate.

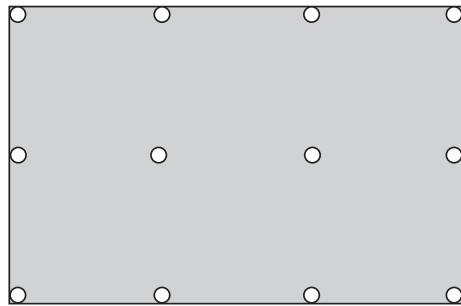

Correct head and row spacing for desired Precipitation Rate

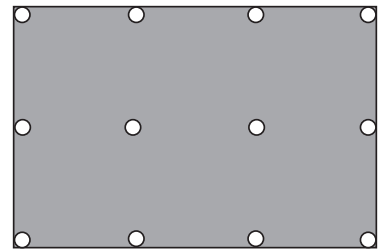

Decreased head and row spacing increases Precipitation Rate

For example, if the sprinkler spacing along a row is reduced by one half (e.g., 20 feet to 10 feet), the precipitation rate would double, as shown by the following calculations.

Precipitation rate for heads on a 20 ft by 20 ft square grid:

$$\begin{aligned} P_r &= \frac{34650 \times \text{GPM (for any arc)}}{\text{Arc (degrees)} \times \text{Head Spacing} \times \text{Row Spacing}} \\ &= \frac{34650 \times 2.5}{180 \times 20 \times 20} \\ &= \frac{86625}{72000} \\ &= 1.20 \text{ in./hr} \end{aligned}$$

Precipitation rate if head spacing is reduced to 10 feet, with row spacing remaining at 20 feet:

$$\begin{aligned} P_r &= \frac{34650 \times \text{GPM (for any arc)}}{\text{Arc (degrees)} \times \text{Head Spacing} \times \text{Row Spacing}} \\ &= \frac{34650 \times 2.5}{180 \times 10 \times 20} \\ &= \frac{86625}{36000} \\ &= 2.40 \text{ in./hr} \end{aligned}$$

As stated, reducing head or row spacing increases the precipitation rate, and increasing head or row spacing decreases the precipitation rate.

## Effect of Radius Adjustment on Precipitation Rate and Distribution Uniformity

Radius adjustment of sprinkler heads is usually accomplished in one of two ways. The first method is an internal change of pressure and flow (GPM); thus, modifying the radius of throw. This is accomplished on fixed-spray heads, fixed-stream spray heads and some rotating stream spray heads by turning an adjustment screw on the top of the head.

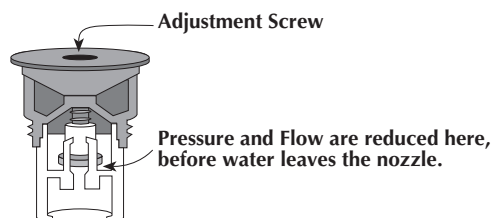

The second method involves external disruption of the spray with no change in flow but a modification in radius of throw. This is typical of rotor and impact heads, and is accomplished by screws, flaps, or pins that disturb the stream of water after it has left the nozzle orifice.

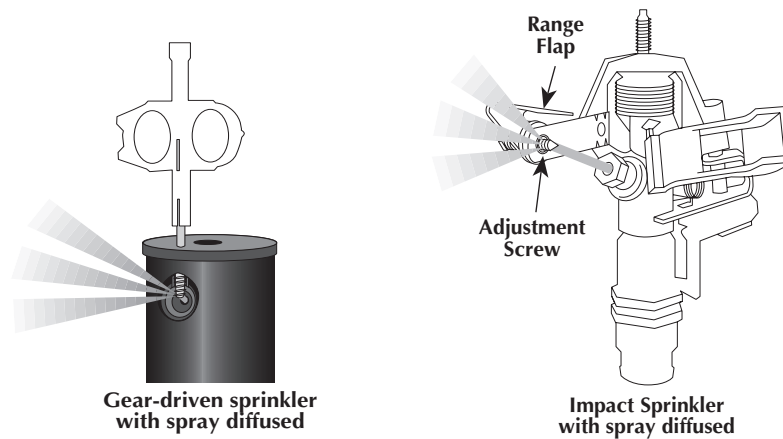

---

Distribution Uniformity, Scheduling Coefficient and other methods of evaluating system uniformity will be explained in more detail in another module. For additional information refer to the 1991 Irrigation Association Technical Conference Proceedings, *Uniformity Statistics for Describing and Comparing Water Distribution Data*, pp. 126-138.

---

It is important to recognize the consequences of radius adjustment on how uniformly the sprinkler distributes water over the irrigated area. One method of describing this uniformity is called Distribution Uniformity. Distribution uniformity (DU) is a measurement of how evenly water is applied to an area. A perfect DU would mean all of the area irrigated received exactly the same amount of water. While desirable, this is virtually impossible to achieve.

Sprinkler manufacturers have designed their sprinklers to operate at peak performance at a given radius. Adjusting the radius below this optimum will reduce the distribution uniformity and lead to dry and wet spots. To understand the effect of radius adjustment on precipitation rate and distribution uniformity, one must consider that the precipitation rate is the *average* rate at which water is applied to an area—this does not take the distribution uniformity into account. For example, two sprinkler systems, both with a precipitation rate of 1.5 in./hr have the same precipitation rate but they will not necessarily distribute the water in each area with the same uniformity.

## Reducing the Radius

As an extreme example, suppose you have a zone of impact sprinklers, with a normal radius of throw of 40 feet, that are spaced 44 feet apart. Now suppose you reduce the radius to 20 feet. Since the head spacing was not changed, and radius reduction on impact heads does not reduce the flow (GPM), the “precipitation rate” remains the same, but the distribution uniformity is much worse than before. **The precipitation rate did not change because the flow and spacing remained the same.** However, the distribution uniformity is much worse because now some areas are not receiving any water.

In another example with fixed-spray heads that have a radius of twelve feet and are spaced at twelve feet, suppose we reduce the radius from twelve to eight feet. With fixed-spray heads, this reduces the flow of water along with the radius. In this case, **the precipitation rate is reduced because the flow (GPM) was reduced (even though the spacing remained the same.)** Since the head spacing was not changed, the distribution uniformity would not be as good as before the radius was reduced.

## Increasing the Radius

If increasing the radius does not include an increase in flow, or does not result in water being applied outside the landscaped area, then increasing the radius without increasing the spacing will not alter the precipitation rate for that area.

## Summary of Effect of Radius Adjustment on Precipitation Rate

Adjusting the radius will alter the system precipitation rate only if:

- head or row spacing is changed.
- flow is changed (this is dependent on sprinkler head design).
- some water previously being applied to the landscaped area is now falling on hardscape or outside the landscaped area (this would result in a slight reduction of the actual precipitation rate along the edges of the system).

Adjusting the sprinkler radius may also adversely affect the spray pattern uniformity and result in poor distribution uniformity and application efficiency.

## Sample Problems: Precipitation Rate Versus Flow, Head/Row Spacing, and Radius Adjustment

Without using the slide rule or making manual calculations, in each of the following problems decide if the precipitation rate should: (A) increase, (B) decrease, or (C) remain the same. (The answers can be found on page 31.)

1. Head spacing is reduced from 30 feet to 25 feet. Row spacing, arc and GPM from the heads remain the same.
2. GPM from the head is reduced from 4.5 GPM to 4.0 GPM. Arc, head and row spacing remain the same.
3. Head spacing is increased from 25 feet to 29 feet. GPM is reduced from 2.0 GPM to 1.7 GPM. Row spacing and arc remain the same.
4. The radius of the impact head is reduced with the range flap or screw. Arc, head and row spacing remain the same.
5. The radius is reduced on a fixed spray head by turning an internal flow adjustment screw. Arc, head and row spacing remain the same.
6. The radius is increased on a gear-drive rotor by turning the radius adjustment screw so it no longer interrupts the spray stream after it has left the sprinkler nozzle. Arc, head and row spacing remain the same.

## Matched Precipitation Rates

A system or zone in which all the heads have similar precipitation rates is said to have matched precipitation rates. A sprinkler by itself does not have a matched precipitation rate. Only when it is used with other sprinklers of similar precipitation rates would they be considered matched (matched implies two or more). When designing sprinkler systems, matching precipitation rates can help to avoid wet and dry spots and excessive run times which leads to high water bills, increased pumping costs, or both.

Both wet and dry areas can be caused by applying water at different precipitation rates. The area with the low precipitation rate becomes a dry spot and the area with the high precipitation rate becomes too wet. Where heads that apply water at substantially different precipitation rates must be used, they should be zoned separately—divided into circuits that are operated by different control valves. Separate control zones can be used to schedule an increase in run times for lower precipitation rate heads in order to equalize the amount of water applied.

## Achieving Matched Precipitation Rates

As discussed earlier, head and row spacing directly affect precipitation rates. There are two other related factors that also affect precipitation rate: the head's arc of coverage and its flow rate in GPM. (In this section, we assume that head and row spacing remain the same.) The following diagram depicts sprinklers with matched precipitation rates.

### MATCHED PRECIPITATION RATE HEADS

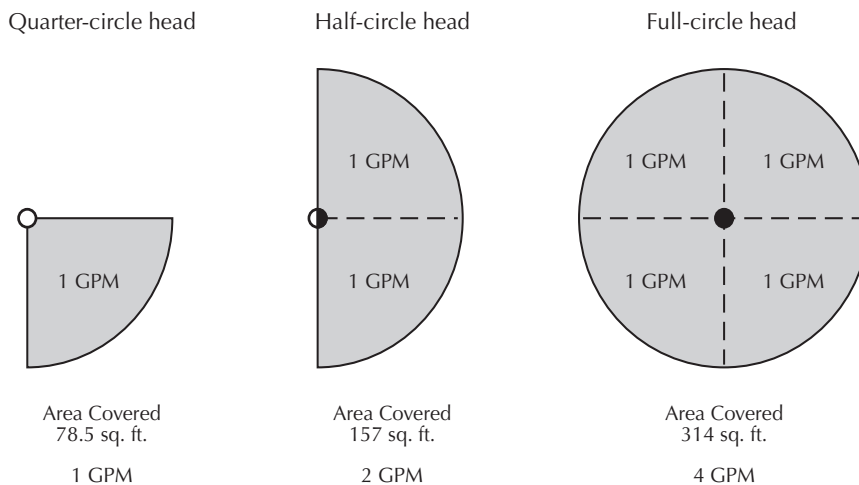

With matched precipitation rates, as the arc of the sprinkler increases, the flow rate also increases. In the previous illustration, the half-circle head covers twice the area of the quarter-circle head, with a flow rate twice that of the quarter-circle head. The full-circle head covers twice the area of the half-circle head and four times the area of a quarter-circle head, and has a flow rate twice that of the half-circle head and four times that of the quarter-circle head.

If the heads in the example all have a 10-ft radius, the arc, area covered, and rate of flow for each would be:

Arc	Area covered by sprinkler	Flow
90°	78.5 sq. ft	1 GPM
180°	157 sq. ft	2 GPM
360°	314 sq. ft	4 GPM

**As the spray arc doubles, so does the flow.** This is a quick way to check for matching precipitation-rate heads. The flow rate of half-circle heads must be two times the flow rate of the quarter-circle heads, and the full-circle heads must have two times the flow rate of the half-circle heads. Manufacturers' specifications often specifically indicate the sprinklers with doubling arcs and flow rates; i.e., the sprinklers considered to have matched precipitation rates.<sup>3</sup>

This principle can be applied to nozzle selection, as well as head selection. Sprinklers with multiple nozzle options can deliver matched precipitation rates if the installer follows the principle of doubling the flow as the arc doubles.

<sup>3</sup> While exact doubling of flow rates is ideal, heads with GPM values within  $\pm 10\%$  of the ideal would be considered to have matched precipitation rates.

## A System Without Matched Precipitation Rates

The following illustration depicts three sprinklers with the same flow rate and three different arcs. (This would occur, for example, if the sprinklers all had the same nozzle installed regardless of arc.)

### SPRINKLER HEADS THAT DO NOT HAVE MATCHED PRECIPITATION RATES

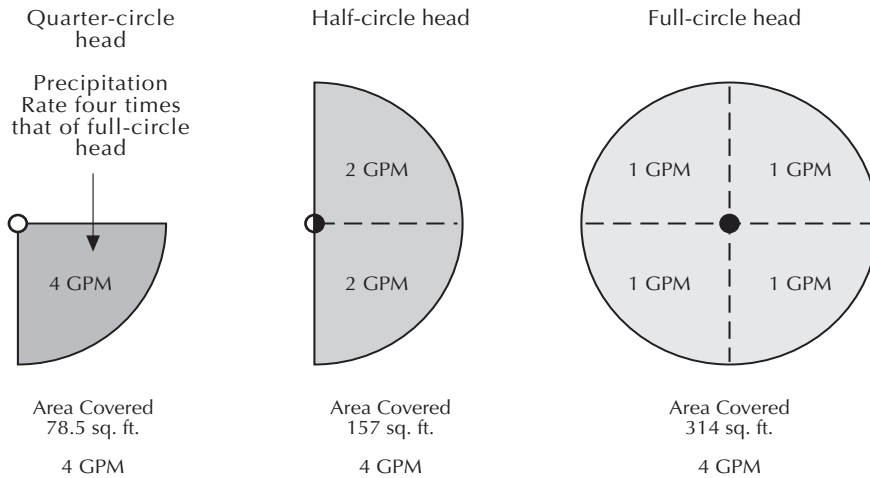

The area covered by the quarter-circle head is receiving four times as much water as the area covered by the full-circle head. If these heads were used on the same control valve, the areas covered by the quarter-circle heads would be too wet or the areas covered by the full-circle heads would be too dry. The use of sprinkler heads on the same valve with widely varying precipitation rates results in poor distribution uniformity and low system efficiency.

## Sample Problems:

### Identifying Matched Precipitation-Rate Heads

For each of the following problems, select the set of sprinklers with matching precipitation rates (the answers can be found on page 31).

1. Which set of sprinkler heads has matched precipitation rates?
  - A. Full-circle (360°) head at 8.0 GPM, half-circle (180°) head at 3.0 GPM, and quarter-circle (90°) head at 1.5 GPM.
  - B. Full-circle (360°) head at 16.0 GPM, half-circle (180°) head at 8.0 GPM, and quarter-circle (90°) head at 2.0 GPM.
  - C. Full-circle (360°) head at 2.0 GPM, half-circle (180°) head at 4.0 GPM, and quarter-circle (90°) head at 8.0 GPM.
  - D. Full-circle (360°) head at 2.0 GPM, half-circle (180°) head at 1.0 GPM, and quarter-circle (90°) head at 0.5 GPM.
  - E. None of the above have matched precipitation rates.
  
2. Which set of sprinkler heads has matched precipitation rates?
  - A. Full-circle (360°) head at 3.8 GPM, half-circle (180°) head at 1.9 GPM, and quarter-circle (90°) head at 0.9 GPM.
  - B. Full-circle (360°) head at 3.2 GPM, half-circle (180°) head at 6.4 GPM, and quarter-circle (90°) head at 12.8 GPM.
  - C. Full-circle (360°) head at 6.0 GPM, half-circle (180°) head at 4.0 GPM, and quarter-circle (90°) head at 2.0 GPM.
  - D. Full-circle (360°) head at 3.0 GPM, half-circle (180°) head at 2.0 GPM, and quarter-circle (90°) head at 1.0 GPM.
  - E. None of the above have matched precipitation rates.

## Proper Use of Matched Precipitation-Rate Heads

Use of matched precipitation-rate heads simplifies the design process by eliminating the need to separate full-circle heads from quarter-circle and half-circle heads. The following diagram illustrates the ability to mix sprinklers with various arcs or flow rates, on the same circuit, if they have matched precipitation rates.

### MATCHED PRECIPITATION RATE SYSTEM

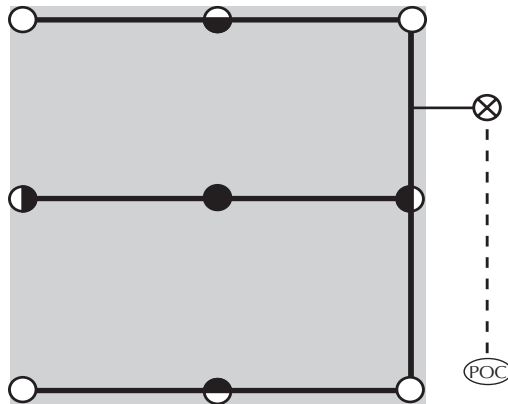

- 4 GPM Full-circle Head
- ◐ 2 GPM Half-circle Head
- 1 GPM Quarter-circle Head
- ⊗ Irrigation Control Valve
- - Irrigation Main Line
- Ⓞ POC Point of Connection

## The Dry Spot Drives the System

When heads that do not have matched precipitation rates are used in the same zone, dry spots develop, and dry spots usually lead to lengthening of sprinkler run times.<sup>4</sup> Since most turf managers or home owners are reluctant to allow dry areas of their lawn to die, the entire area is watered longer to ensure that sufficient water is applied to keep the dry spot alive.

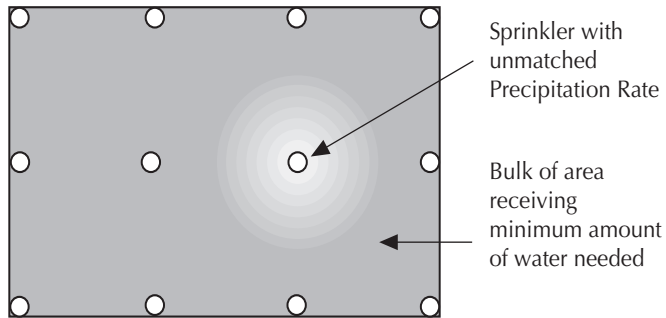

In this diagram, one sprinkler has a different precipitation rate than the others, causing a “dry spot” to develop. The remaining area receives the minimum amount of water needed.

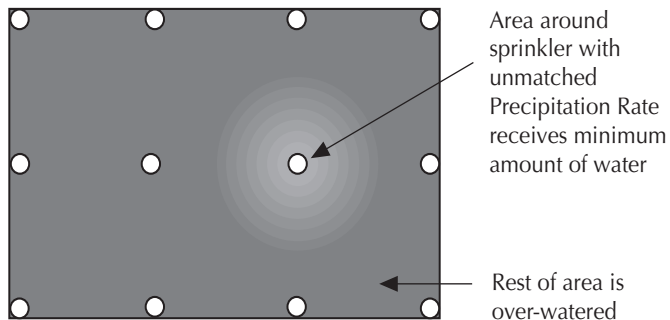

In order to apply the minimum amount of water needed to satisfy the “dry spot,” all the remaining areas are over-watered.

<sup>4</sup> When scheduling irrigation, dry spots are measured by the “Scheduling Coefficient.” The Scheduling Coefficient is an indication of the additional sprinkler run time necessary to compensate for dry spots.

## Matched Precipitation Rates Using Multiple Nozzle Selections

The first heads to achieve matched precipitation rates were the spray heads with fixed arcs. As awareness of the importance of matched precipitation rates increased, the concept was incorporated into rotor heads through the use of multiple nozzle sets. With these sets, the designer or installer can select the nozzle combinations best suited for their design situation while maintaining a matched precipitation rate.

The selection of nozzles to achieve matched precipitation rates follows the same principles as those discussed for the fixed-arc heads. For heads with the same radius of throw, as the arc is increased, the flow rate of the sprinkler head should increase proportionally (quarter-circle head at 1 GPM, half-circle head at 2 GPM, etc.)

Referring to the following chart, the nozzles selected for matched precipitation rates could be as follows:

30 foot spacing at 50 PSI:

Quarter-circle	Half-circle	Full-circle
No. 2 Nozzle	No. 5 Nozzle	No. 8 Nozzle

40 foot spacing at 50 PSI:

Quarter-circle	Half-circle	Full-circle
No. 4 Nozzle	No. 7 Nozzle	No. 10 Nozzle

These nozzle combinations remain within our target range of a  $\pm 10\%$  variation between precipitation rates for heads operated by the same control valve.

## Performance Data

### PGP Standard Nozzles – 25 Degree Trajectory

PGP Standard Nozzle (Red)					
Performance Data					
Nozzle	Pressure PSI	Radius ft.	Flow GPM	Precip in/hr ■ ▲	
<b>1</b>	30	28'	0.5	0.12	0.14
	40	29'	0.6	0.14	0.16
	<b>50</b>	<b>29'</b>	<b>0.7</b>	<b>0.16</b>	<b>0.19</b>
	60	30'	0.8	0.17	0.20
<b>2</b>	30	29'	0.7	0.16	0.19
	40	30'	0.8	0.17	0.20
	<b>50</b>	<b>30'</b>	<b>0.9</b>	<b>0.19</b>	<b>0.22</b>
	60	31'	1.0	0.20	0.23
<b>3</b>	30	30'	0.9	0.19	0.22
	40	31'	1.0	0.20	0.23
	<b>50</b>	<b>31'</b>	<b>1.2</b>	<b>0.24</b>	<b>0.28</b>
	60	32'	1.3	0.24	0.28
<b>4</b>	30	32'	1.2	0.23	0.26
	40	33'	1.4	0.25	0.29
	<b>50</b>	<b>34'</b>	<b>1.6</b>	<b>0.27</b>	<b>0.31</b>
	60	34'	1.8	0.30	0.35
<b>5</b>	30	34'	1.6	0.27	0.31
	40	36'	1.8	0.27	0.31
	<b>50</b>	<b>38'</b>	<b>2.0</b>	<b>0.27</b>	<b>0.31</b>
	60	38'	2.2	0.29	0.34
<b>6</b>	30	34'	2.0	0.33	0.38
	40	36'	2.4	0.36	0.41
	<b>50</b>	<b>38'</b>	<b>2.7</b>	<b>0.36</b>	<b>0.42</b>
	60	38'	2.9	0.39	0.45
<b>7</b>	30	34'	2.6	0.43	0.50
	40	38'	3.0	0.40	0.46
	<b>50</b>	<b>40'</b>	<b>3.4</b>	<b>0.41</b>	<b>0.47</b>
	60	40'	3.7	0.45	0.51
<b>8</b>	30	37'	3.2	0.45	0.52
	40	39'	3.7	0.47	0.54
	<b>50</b>	<b>41'</b>	<b>3.9</b>	<b>0.45</b>	<b>0.52</b>
	60	42'	4.6	0.50	0.58
<b>9</b>	30	38'	3.6	0.48	0.55
	40	41'	4.3	0.49	0.57
	<b>50</b>	<b>44'</b>	<b>5.2</b>	<b>0.52</b>	<b>0.60</b>
	60	45'	5.5	0.52	0.60
<b>10</b>	40	44'	6.0	0.60	0.69
	50	46'	6.8	0.62	0.71
	<b>60</b>	<b>47'</b>	<b>7.6</b>	<b>0.66</b>	<b>0.76</b>
	70	49'	8.2	0.66	0.76
<b>11</b>	40	46'	8.0	0.73	0.84
	50	48'	8.9	0.74	0.86
	<b>60</b>	<b>50'</b>	<b>9.8</b>	<b>0.75</b>	<b>0.87</b>
	70	51'	10.5	0.78	0.90
<b>12</b>	40	46'	10.5	0.96	1.10
	50	48'	11.9	0.99	1.15
	<b>60</b>	<b>50'</b>	<b>12.7</b>	<b>0.98</b>	<b>1.13</b>
	70	52'	14.1	1.00	1.16

Note: All precipitation rates calculated for 180 degree operation.  
For the precipitation rate for a 360 degree sprinkler, divide by 2.

## Selecting Nozzles for Odd-Arc Heads

---

With multiple nozzle selection it is possible to match precipitation rates in odd arcs as well. For example, full-circle PGP's with No. 8 nozzles, spaced 35 feet apart at 50 PSI, have flow rates of 4.2 GPM each. A 270° head is needed on the same valve. Follow the steps below to determine the proper nozzle.

To match the precipitation rate of one spray arc with another, first determine the appropriate flow rate for the desired arc using the following formula:

$$\text{GPM}_x = (\text{Arc}_x / \text{Arc}_a) \times \text{GPM}_a$$

where:

**GPM<sub>x</sub>** is the flow rate (in GPM) of the new head.

**Arc<sub>x</sub>** is the arc (in degrees) of the new head.

**Arc<sub>a</sub>** is the arc (in degrees) of the existing head.

**GPM<sub>a</sub>** is the flow rate (in GPM) of the existing head.

For the previous example, the calculation would be:

$$\begin{aligned}\text{GPM}_x &= (\text{Arc}_x / \text{Arc}_a) \times \text{GPM}_a \\ &= (270 / 360) \times 4.2 \\ &= 0.75 \times 4.2 \\ &= 3.15\end{aligned}$$

With this rate of flow (3.15 GPM), you can check the nozzle performance chart to find the nozzle which most closely matches the desired GPM. In this case, it would be a No. 7 nozzle with 3.4 GPM at 50 PSI. While this does not match our target GPM exactly, it will provide a precipitation rate of 0.36 in./hr for the 270° head, versus 0.33 in./hr for the full-circle head. This precipitation rate remains within our target range of a ±10% variance.

---

Using the formulas for selecting nozzles for odd arcs may be confusing to some students. In cases where the majority of the students have struggled with the previous formulas, it may be appropriate to inform them of the use for this formula but not go into detail. Students interested can follow through with the sample problems after the class session.

---

---

At the end of a **Level II** or **Level III** presentation also ask the students to develop definitions or descriptions for the following without looking in the manual:

1. The Effect of Flow Rate on Precipitation Rates.
  2. The Effect of Head/Row Spacing on Precipitation Rates.
  3. The Effect of Radius Adjustment on Precipitation Rates.
  4. Matched Precipitation Rates.
  5. The Dry Spot Drives the System.
- 

## Sample Problems:

### Selecting Nozzles for Matched Precipitation Rates

For these problems, use the Nozzle Performance Chart shown in the previous section to select the appropriate nozzle for the desired arc to match the existing arc/nozzle combination. (The answers to these sample problems can be found on page 32.)

1. The existing heads are full-circle heads ( $360^\circ$ ) spaced 48 feet apart, using No. 10 nozzles (6.8 GPM) at 50 PSI. You need to add a  $270^\circ$  head to the same circuit. Find the nozzle that will match (within  $\pm 10\%$ ) the existing precipitation rate of 0.28 in./hr
2. The existing heads are half-circle heads ( $180^\circ$ ) spaced 36 feet apart, using No. 5 nozzles (1.8 GPM) at 40 PSI. You need to add a  $110^\circ$  head to the same circuit. Find the nozzle that will match (within  $\pm 10\%$ ) the existing precipitation rate of 0.27 in./hr
3. The existing heads are half-circle heads ( $180^\circ$ ) spaced 40 feet apart, using No. 6 nozzles (2.9 GPM) at 60 PSI. You need to add a  $270^\circ$  head to the same circuit. Find the nozzle that will match (within  $\pm 10\%$ ) the existing precipitation rate of 0.35 in./hr

## Summary

---

### Precipitation Rate

- A. How fast water is applied, as measured in inches per hour.
- B. An amount of water applied over a period of time, usually measured in inches per hour.

### Sprinkler Precipitation Rate

When the precipitation rate for a “sprinkler” is given, it refers to the precipitation rate of a group of heads used together and all having the same arc, spacing and GPM.

### System Precipitation Rate

The precipitation rate for a “system” is the average precipitation rate of all sprinklers in a given area regardless of the arc, spacing, or flow rate of each head.

### Use of Precipitation Rates in Landscape Irrigation

Sprinkler Head Selection

Scheduling Sprinkler Run Time

### Effect of Sprinkler Flow Rate on Precipitation Rate

The precipitation rate of a sprinkler or system varies directly with the flow rate (in GPM) of the sprinkler. When sprinkler spacing remains constant, increasing sprinkler GPM increases the precipitation rate, and decreasing sprinkler GPM decreases the precipitation rate.

### Effect of Head/Row Spacing on Precipitation Rate

The precipitation rate of a sprinkler or system varies inversely with head and row spacing. When sprinkler GPM remains the same, decreasing head or row spacing increases precipitation rate, while increasing head or row spacing decreases precipitation rate.

### Effect of Radius Adjustment on Precipitation Rate

Adjusting the radius of a sprinkler head will affect the precipitation rate only if one of the following occur: (1) head or row spacing is changed, (2) flow is changed (this is dependent on sprinkler head design), or (3) some water previously being applied to the landscaped area is now falling on hardscape or outside the landscaped area.

### Matched Precipitation Rate

A system (or zone) with a matched precipitation rate is one in which all the heads have similar precipitation rates.

## Answers to Sample Problems

---

Answers to the Sprinkler Spacing Method problems (page 10):

$$\begin{aligned} 1. \quad P_r &= \frac{34650 \times \text{GPM (for any arc)}}{\text{Arc (degrees)} \times \text{Head Spacing} \times \text{Row Spacing}} \\ &= \frac{34650 \times 3.5}{360 \times 30 \times 30} \\ &= \frac{121275}{324000} \\ &= 0.37 \text{ in./hr} \end{aligned}$$

$$\begin{aligned} 2. \quad P_r &= \frac{34650 \times \text{GPM (for any arc)}}{\text{Arc (degrees)} \times \text{Head Spacing} \times \text{Row Spacing}} \\ &= \frac{34650 \times 0.5}{90 \times 15 \times 13} \\ &= \frac{17325}{17550} \\ &= 0.99 \text{ in./hr} \end{aligned}$$

$$\begin{aligned} 3. \quad P_r &= \frac{34650 \times \text{GPM (for any arc)}}{\text{Arc (degrees)} \times \text{Head Spacing} \times \text{Row Spacing}} \\ &= \frac{34650 \times 1.75}{270 \times 9 \times 7.5} \\ &= \frac{60637.5}{18225} \end{aligned}$$

$$\begin{aligned} 4. \quad P_r &= 3.33 \text{ in./hr} \\ &= \frac{34650 \times \text{GPM (for any arc)}}{\text{Arc (degrees)} \times \text{Head Spacing} \times \text{Row Spacing}} \\ &= \frac{34650 \times 10.5}{120 \times 50 \times 55} \\ &= \frac{363825}{330000} \end{aligned}$$

1.1 in./hr

Answers to the Total Area Method problems (page 12):

$$P_r = \frac{96.25 \times \text{Total GPM}}{\text{Total Area}}$$

$$= \frac{96.25 \times 25}{2100}$$

$$= \frac{2406.25}{2100}$$

2.  $P_r = 1.15$  in./hr

$$P_r = \frac{96.25 \times \text{Total GPM}}{\text{Total Area}}$$

$$= \frac{96.25 \times 250}{43560}$$

$$= \frac{2406.25}{43560}$$

0.55 in./hr

Answers to the precipitation rate versus flow and spacing problems (page 18):

1. Precipitation rate will increase.
2. Precipitation rate will decrease.
3. Precipitation rate will decrease.
4. Precipitation rate will remain the same.
5. Precipitation rate will decrease.
6. Precipitation rate will remain the same for most areas unless over-spray occurs along the perimeter of the irrigated area.

Answers to the identification of matched precipitation-rate head problems (page 22):

1. D.
2. A.

Answers to the nozzle selection for matched precipitation-rate problems (on page 28):

1. First find the appropriate rate of flow (GPM) for the 270° head:

$$\begin{aligned} \text{GPM}_x &= (\text{Arc}_x / \text{Arc}_k) \times \text{GPM}_k \\ &= (270 / 360) \times 6.8 \\ &= 0.75 \times 6.8 \\ &= 5.1 \end{aligned}$$

Next use the performance chart to find the nozzle that most closely matches 5.1 GPM at the existing sprinkler operating pressure (50 PSI). The Standard No. 9 nozzle delivers 5.5 GPM at 50 PSI. This is the flow rate closest to our target of 5.1 GPM. With this nozzle, the precipitation rate for a 270° head spaced 48 ft apart, with a flow of 5.1 GPM, produces the desired precipitation rate, 0.28 in./hr.

2. First find the appropriate rate of flow (GPM) for the 110° head:

$$\begin{aligned} \text{GPM}_x &= (\text{Arc}_x / \text{Arc}_k) \times \text{GPM}_k \\ &= (110 / 180) \times 1.8 \\ &= 0.61 \times 1.8 \\ &= 1.1 \end{aligned}$$

Next use the performance chart to find the nozzle that most closely matches 1.1 GPM at the existing sprinkler operating pressure (40 PSI). The Standard No. 3 nozzle delivers 1.0 GPM at 40 PSI. When spaced 36 ft apart, the precipitation rate for the No. 3 nozzle would be 0.24 in./hr, which is within ±10% of the target of 0.27 in./hr.

3. First find the appropriate rate of flow (GPM) for the 270° head:

$$\begin{aligned} \text{GPM}_x &= (\text{Arc}_x / \text{Arc}_k) \times \text{GPM}_k \\ &= (270 / 180) \times 2.9 \\ &= 1.5 \times 2.9 \\ &= 4.35 \end{aligned}$$

Next use the performance chart to find the nozzle that most closely matches 4.35 GPM at the existing sprinkler operating pressure (60 PSI). The Standard No. 8 nozzle delivers 4.6 GPM at 60 PSI. When spaced 40 feet apart, the precipitation rate for the No. 8 nozzle would be 0.39 in./hr, which is within ±10% of the target of 0.35 in./hr.

## Calculating Precipitation Rate Formulas

Depending upon the construction of the irrigation system, the precipitation rate may be calculated by either a “sprinkler spacing” or a “total area” method.

**Sprinkler Spacing Method...** The precipitation rate should be calculated for each individual zone. If all sprinkler heads on the zone have the same spacing, flow rate, and arc of coverage, use one of the following formulas:

Any Arc and Any Spacing (■):

$$\text{P.R. (in/hr)} = \frac{\text{GPM (for any Arc)} \times 34,650}{\text{Degrees of Arc} \times \text{Head Spacing (ft)} \times \text{Row Spacing (ft)}}$$

$$\text{P.R. (mm/hr)} = \frac{\text{m}^3/\text{hr (for any Arc)} \times 360,000}{\text{Degrees of Arc} \times \text{Head Spacing (m)} \times \text{Row Spacing (m)}}$$

$$\text{P.R. (mm/hr)} = \frac{\text{l/min (for any Arc)} \times 21,600}{\text{Degrees of Arc} \times \text{Head Spacing (m)} \times \text{Row Spacing (m)}}$$

Equilateral Triangular Spacing (▲):

$$\text{P.R. (in/hr)} = \frac{\text{GPM of 360 Arc} \times 96.25}{(\text{Head Spacing})^2 \times .866}$$

$$\text{P.R. (mm/hr)} = \frac{\text{l/min of 360 Arc} \times 60}{(\text{Head Spacing})^2 \times .866}$$

$$\text{P.R. (mm/hr)} = \frac{\text{m}^3/\text{hr of 360 Arc} \times 1,000}{(\text{Head Spacing})^2 \times .866}$$

**Total Area Method...** The precipitation rate for a “system” is the *average* precipitation rate of *all* sprinklers in an area, regardless of the spacing, flow rate, or arc for each head. The Total Area Method calculates all the flows of all of the heads in any given area.

$$\text{P.R. (in/hr)} = \frac{\text{Total GPM} \times 96.25}{\text{Total Area}}$$

**Notes:**



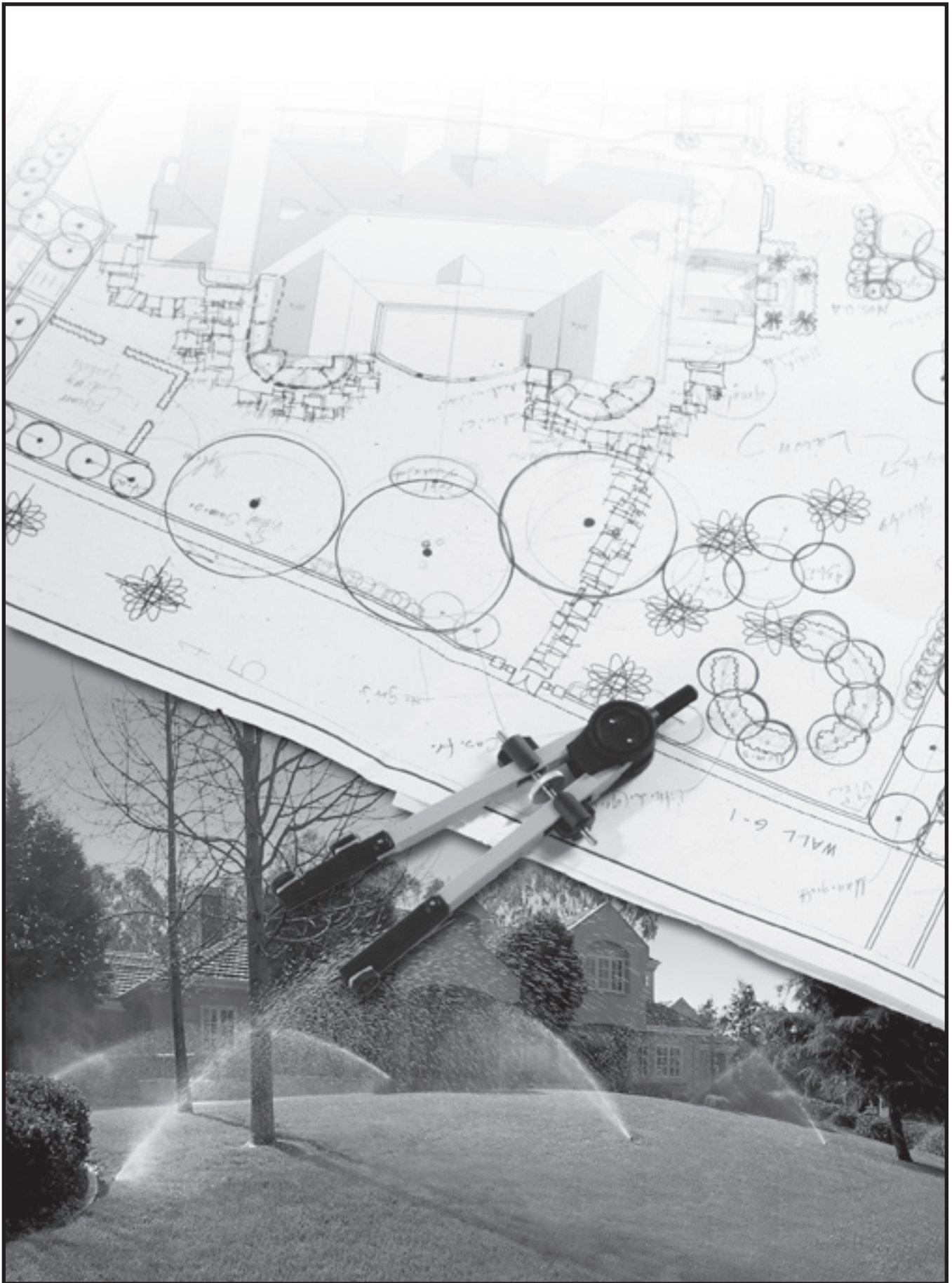

**Hunter Industries • The Irrigation Innovators**

1940 Diamond St. • San Marcos, CA 92078 • U.S.A. • Tel: 760-774-5240 • Fax: 760-744-7461  
www.HunterIndustries.com

P/N 701001  
ED-001.A 6/05