

USER'S GUIDE TO POWDER COATING

Third Edition

Darryl L. Ulrich
Editor



Published by the Society of Manufacturing
Engineers in cooperation with the Association
for Finishing Processes of SME



31837 PDF

ABOUT THIS BOOK

Boasting significant advantages over liquid finishes, powder coating technology has received mushrooming acceptance in recent years. It now constitutes 10% of the total industrial finishing market in North America.

A major driving force behind the growth of powder coating is environmental regulation of air, water, and waste disposal. Such regulation has a hard-hitting, detrimental impact on liquid finishes, which must have venting, filtering, and solvent recovery systems to control volatile organic compounds (VOCs). Powder, being a dry finish, contains no VOCs, making powder users much less encumbered by environmental regulations. The nature of powder coating also makes it economical to use and safer and more comfortable for workers than its liquid counterpart.

Concurrent with powder coating's growing popularity is research and development enhancing the technology and opening it up to more applications. These new developments prompted the publication of this third edition of "User's Guide to Powder Coating." The book is a storehouse of updated information for current and potential powder coating users. Its editor and contributors—people on the cutting edge of the powder coating technology—provide readers with the most recent hows, whens, and whys of powder coating.

ABOUT THE EDITOR

Darryl L. Ulrich is vice president/general manager, Powder Technology Inc., Schofield, Wisconsin.

As of 1993, Mr. Ulrich spent 34 years in the paint and coatings industry, the last 23 years in powder coatings. His work experience covers the areas of research and development, sales and technical services, and management in the fields of trade sales and industrial coatings.

Mr. Ulrich's powder coating experience began in 1970 at Cargill, Inc. His advent into the technology was sparked by the development and commercialization of polyester powder resins for use with urethane curing agents used in some powder coatings. In 1979 he joined H.B. Fuller Company as laboratory manager of the Industrial Coatings Department. In 1983 he became director of Research and Technical Services of the company's Industrial Coatings Division. In 1985 he joined the O'Brien Corporation as technical sales representative based in Minneapolis, Minnesota. In 1987, Mr. Ulrich became a partner in a new powder manufacturing company, serving as vice president and general manager of Powder Technology Inc., a custom manufacturer of powder coatings.

He is a member of the Association for Finishing Processes of the Society of Manufacturing Engineers (AFP/SME), and the Chemical Coaters Association. Activities within AFP/SME include serving as session chair at Finishing '81 and '83 and as conference chair at Finishing '85 and '87. In 1983, he received the AFP Technical Division Contribution Award.

Mr. Ulrich lectures at the University of Wisconsin Powder Coating Short Course.



Society of
Manufacturing
Engineers

C0122L
31837 PDF

**USER'S GUIDE TO
POWDER COATING**
Third Edition

CONTRIBUTORS

Gregory J. Bocchi
Powder Coating Institute

Gerald W. Crum
Nordson Corporation

Charles Danick
Cargill Resin Products Division

Peter R. Gribble
Ferro Corporation

Brad B. Gruss
Fremont Industries, Inc.

Jeffrey W. Hale
Gema-Volstatic Incorporated

Steven L. Kiefer
Morton International, Inc.

Ken Kreeger
Nordson Corporation

Nicholas P. Liberto, PE
Powder Coating Consultants Division of Ninan, Inc.

Gus Lissy
GLA Finishing Systems

Kevin Loop
Navistar Corporation

Rick Morgan
Nordson Corporation

Atam P. Sahni
Ferro Corporation

James M. Sales
Ultimate Metal Finishing Corporation

George R. Trigg
GRT Engineering

James F. Zeis, CMfgE
Uni Spray

**USER'S GUIDE TO
POWDER COATING**
Third Edition

Darryl L. Ulrich
Editor

Prepared By

Association for Finishing Processes of
the Society of Manufacturing Engineers

SOCIETY OF MANUFACTURING ENGINEERS
Dearborn, Michigan

Copyright © 1993 by Society of Manufacturing Engineers

Third Edition

98765

All rights reserved, including those of translation. This book, or parts thereof, may not be reproduced in any form or by any means, including photocopying, recording, or microfilming, or by any information storage and retrieval system, without permission in writing of the copyright owners.

No liability is assumed by the publisher with respect to the use of information contained herein. While every precaution has been taken in the preparation of this book, the publisher assumes no responsibility for errors or omissions. Publication of any data in this book does not constitute a recommendation of any patent or proprietary right that may be involved or provide an endorsement of products.

Library of Congress Catalog Card Number: 93-085795
International Standard Book Number: 0-87263-444-2

Additional copies may be obtained by contacting:

Society of Manufacturing Engineers
Customer Service
One SME Drive
Dearborn, Michigan 48121
1-800-733-4763

SME staff who participated in producing this book:
Senior Editor: Larry Binstock
Production Secretary: Dorothy Wylo
Association Manager: Cheri Willetts

Printed in the United States of America

about AFP/SME

The Association for Finishing Processes of SME (AFP/SME) is the principal educational association for those involved with paint and coating applications worldwide. It was founded in 1975 to provide an informational interchange among producers of coatings and pretreatment applicators, product designers, equipment manufacturers, users, and coatings operations professionals, those responsible for environmental compliance and finishing consultants.

The Association's goal is to provide leadership and knowledge concerning the finishing industry. Its objectives are to expand the use of new technologies and meet the rapidly changing needs of its constituents. AFP/SME serves individuals by promoting finishing as a career. It serves companies by promoting technical excellence. The Association also serves the environment by promoting effective management and operational techniques.

In pursuit of its goal, AFP/SME sponsors conferences, clinics, and courses around the country. Topics for these sessions include: industrial painting processes, production painting, systems design, troubleshooting coating defects, liquid and powder coating, radiation curing, plastic finishing, robot finishing, wood finishing, and environmental compliance.

In addition, AFP/SME publishes books, reports, *The Finishing Line* technical quarterly, and pocket guides to provide current technical information on all aspects of industrial finishing.

In joining AFP/SME, an individual also becomes a member of the Society of Manufacturing Engineers and receives *Manufacturing Engineering* magazine. The Society presently comprises over 75,000 manufacturing-oriented members in some 70 countries throughout the world.

For more information call the AFP/SME Manager at (313) 271-1500, ext. 544.

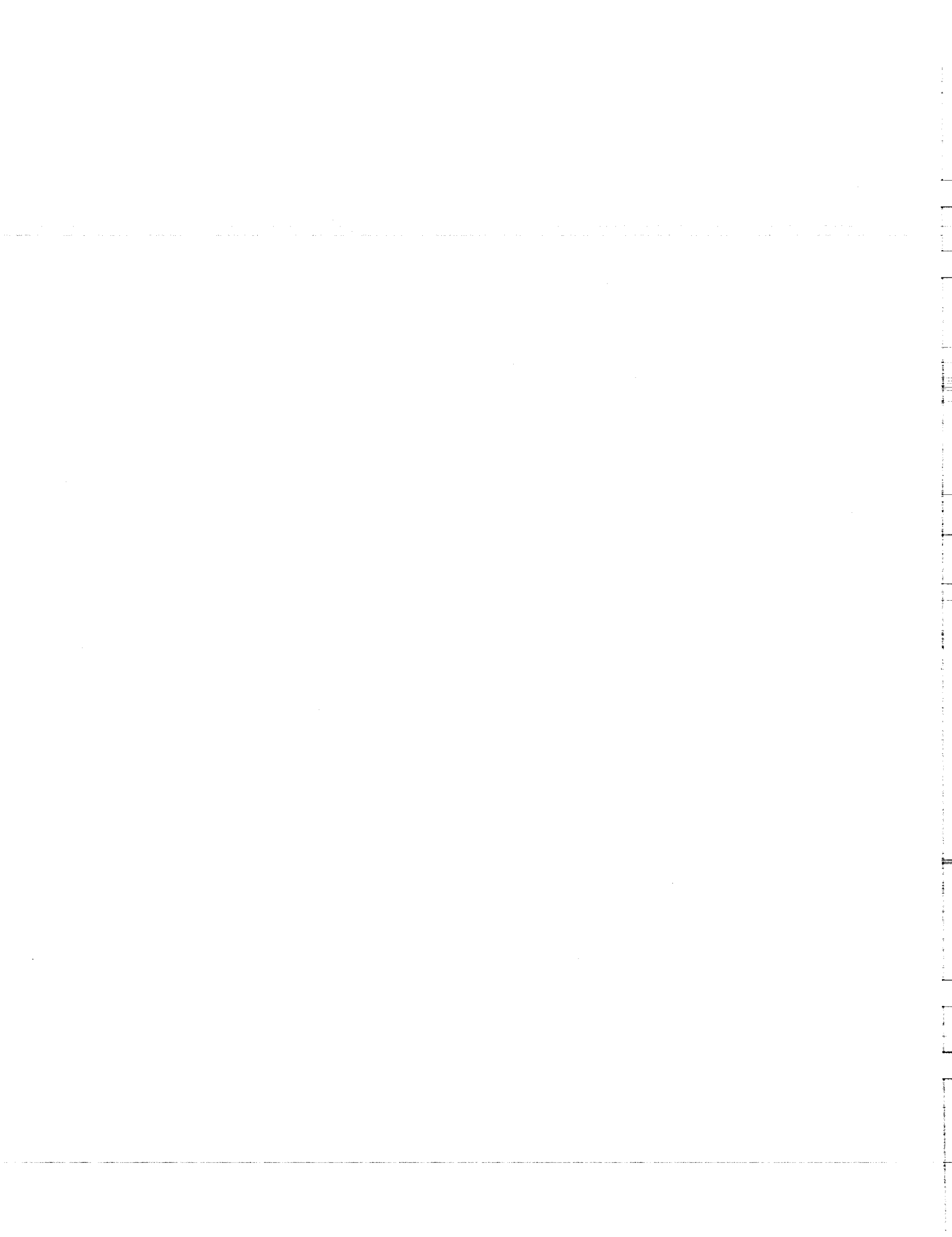

TABLE OF CONTENTS

Preface	ix
Chapter 1: WHY POWDER COATING?	1
Economic Considerations.....	1
Applications.....	2
Environmental Implications.....	2
Powder Coating Growth.....	3
Chapter 2: POWDER COATING MATERIALS	5
Thermoplastic Powder Coatings.....	5
Thermoset Powder Coatings.....	6
Polyester Resin-based Powder Coatings.....	9
Coating Selection.....	13
Safety.....	13
Chapter 3: ECONOMIC ADVANTAGES OF POWDER COATING	17
Cost Savings.....	17
Environmental Factors.....	18
Plant Safety.....	19
Application Evaluation.....	19
Chapter 4: SURFACE PREPARATION	25
Cleaning Methods.....	25
Chemical Surface Preparation.....	29
Cleaning Galvanized Steel.....	29
Cleaning Aluminum.....	31
Cleaning Steel.....	34
Chapter 5: METHODS OF APPLYING POWDER COATINGS	39
Fluidized Powder Bed Process.....	39
Electrostatic Fluidized Bed Process.....	42
Electrostatic Powder Spray Coating.....	46
Equipment.....	47
Operation.....	49
Application Factors.....	52
Operation Conditions.....	53

Chapter 6: POWDER SPRAY BOOTHS AND RECOVERY SYSTEMS.....	55
Spray Booths.....	55
Collector System.....	59
Color Change Considerations.....	64
Chapter 7: DESIGN CONSIDERATIONS FOR OPERATION OF POWDER COATING SYSTEMS.....	67
Operation of Powder Coating System.....	68
Chapter 8: HEATING APPLICATION.....	73
Preheating.....	73
Postheating.....	73
Process Considerations.....	74
Available Methods of Heating.....	74
Oven Cavity Atmosphere.....	75
Safety.....	75
Chapter 9: POWDER STORAGE AND HANDLING.....	77
Storage Recommendations.....	78
Safety.....	78
Chapter 10: REPAIR OF PARTS AND HANGER STRIPPING.....	81
Touch-up.....	81
Recoat.....	81
Rebake.....	82
Stripping.....	82
General.....	83
Chapter 11: QUALITY CONTROL.....	85
SPC.....	85
Avoiding and Correcting Quality Variations.....	85
POWDER COATINGS TODAY AND TOMORROW.....	107
Index.....	111

PREFACE

Painting, coating, or finishing—whatever term you choose—has been around for thousands of years. From the earliest recorded history, and probably long before that, the human race has “painted” for decoration, protection, and combinations of both.

From the ancient Chinese lacquered or shellacked leather suits of armor to the modern materials of the space shuttle heat shields, coatings have been used to beautify and protect the substrate or article being coated.

Coatings have indeed come a long way. However, not all advances were good. Along with improvements in performance, reductions in cost, and increased manufacturing volumes have come many disposal problems. Toxic wastes entering our air, soil, and water from the finishing industry are being targeted for drastic reductions and/or elimination. I am not suggesting in the least that the finishing industry is the sole cause of America's pollution problems. It is, however, one of the additive factors and does come under local, state, and federal regulations regarding use and disposal.

The technology of powder coatings offers the finishing industry a way to more easily meet the new pollution and disposal requirements. Developments in materials and equipment offer the finisher better quality, wider selection, higher transfer efficiencies, and lower overall finishing costs when compared to noncompliant coatings.

In the past few years there has been a lot of effort to develop materials that will allow powder into new markets. Super durable powders are being investigated that will compete in the silicone polyester and fluorocarbon market. New resin systems will enable formulators to reduce costs in the general purpose area; perhaps even compete with the “little red wagon paint.”

Equipment developments allow easier and faster color change or give high enough efficiency so that reclaim may not be necessary to give the economic advantage to powder.

Suppliers of pigment and other additives recognize the powder industry as a viable market and have started to increase their efforts to meet industry needs.

New and potential entrants in powder coating manufacturing promise the coater more choices and the possibilities of small batch, special color runs.

One recent development is a high-temperature silicone powder currently used on muffler and exhaust manifolds. Operating temperatures and test temperatures exceed 1000°F (538°C). Other lower temperature silicone modified powders are being tested on items such as gas grills. Temperatures are in the range of 600 to 800°F (316 to 427°C).

Powder is one of the fastest growing new coating technologies. It cannot be used for everything, but where the substrate is, or can be made, electrically conductive to allow electrostatic spraying and/or heated to a range of 275 to 400°F (135 to 204°C), powder may well be the best choice. Where they can be used, powder coatings deliver a combination of quality, economics, efficiency, and safety in the finishing industry.

To keep the finishing industry abreast of all the many developments in powder coating technology, the Association of Finishing Processes of the Society of Manufacturing Engineers presents this third edition of the *User's Guide to Powder Coating*.

Darryl L. Ulrich
Editor

CHAPTER 1

WHY POWDER COATING?

The use of powder coating as a finishing process has grown significantly in the past several years. More and more finishing engineers have turned to powder coating as a way to produce a high-quality finish while increasing production, cutting costs, and complying with increasing environmental pressures. Also, ongoing technological breakthroughs are continually knocking down the few barriers that hindered powder coating's ability to grow in the market. In fact, powder coating now constitutes 15% of the finishing market where it competes directly with traditional liquid finishes. It covers over 10% of the total industrial finishing market in North America.

With recent and pending environmental regulations on air and water emissions and waste disposal, the switch from liquid to powder finishing is becoming more prevalent. Liquid finishing requires the use of solvents to convey the resinous binder over a surface. These liquid solvents necessitate venting, filtering, and solvent recovery systems to control volatile organic compounds (VOCs). Powder coating, on the other hand, is a dry finish, which does not use VOCs during any part of the finishing operation.

In powder coating, the finely ground particles of pigment and resin are electrostatically charged and sprayed onto a metal part. The coating process can be done manually or automatically with a wide variety of equipment available to small and large end users. The parts to be coated are grounded neutral so that the charged particles projected at them adhere to the parts and are held there until melted and fused into a smooth coating in the curing ovens. The result is a uniform, durable, high-quality finish.

ECONOMIC CONSIDERATIONS

The excellence of the powder-coated finish is accompanied by substantial cost savings, when compared to liquid coating systems. Since powder contains no VOCs, air used to exhaust the powder spray booth can be recirculated directly to the plant, eliminating the cost of heating or cooling the makeup air. Ovens that cure solvent-based coatings must heat and exhaust huge volumes of air to ensure that the solvent fumes do not reach a potentially explosive level. With no solvent in powder coating, the exhaust required in the ovens is lower, resulting in energy and cost savings in spite of the higher curing temperatures that powder coating requires.

Labor and Efficiency Savings

There are savings in labor costs because less training is required to operate a powder coating system, and there is no mixing of powder with solvents or catalysts. Maintenance costs are also low, as most clean-ups can be done with a vacuum.

The powder application system can also bring greater operating efficiency to the finishing operation, which can save both time and money. Parts can be racked closer together on a conveyor, so more parts can pass through a production line in a given period of time, resulting in lower unit costs. More parts can also be coated automatically, as powder coating does not run, drip, or sag, resulting in significantly lower reject rates. And with appropriate application equipment, powder materials, and efficient recovery methods, one-coat application and overall powder utiliza-

Chapter 1

tion efficiency of 95% to 98% is readily achievable. If more than one color is required, color change can be accomplished in a relatively short period of time. And up to 99% of the powder sprayed at the product surface, but not adhering, can be recovered and reused, resulting in minimal waste disposal costs.

Today's powder coatings offer a wide range of performance properties and glosses, and can match virtually any color or texture. Film thicknesses from under one mil (.03 mm) to over 15 mil (.38 mm) are possible.

APPLICATIONS

Powder coatings are now used in hundreds of applications. As market potential grows, research devoted to product improvement also increases, leading to further innovations and market expansion.

Powder Coating Markets

One of the biggest potential powder coating users is the appliance industry. The high-quality finish is both attractive and durable, and a viable alternative for porcelain enamel and liquid finishes on traditional appliance surfaces. These include dryer drums, front and side panels of ranges and refrigerators, washer tops and lids, air conditioner cabinets, water heaters, dishwasher racks, and cavities of microwave ovens. Technological developments have resulted in powder coatings with lower gloss, lower temperature curing requirements, and stronger resistance to chips, scratches, detergents, and grease. All these features have led to the use of powder coatings on about 40% of all appliance finishes. Appliance applications represent about 21% of the North American powder coating market.

The automotive industry represents an additional 15% of the North American powder coating market. Wheels, bumpers, roof racks, door handles, interior panels, and various "under-the-hood" parts are being powder coated. Powder is also used as a primer-surfacer on component parts for trucks and recreational vehicles. Clear

powders, over a liquid base coat, are being developed for exterior auto body finishing.

The architectural and building market uses powder coating on file cabinets, shelving, aluminum extrusions for window frames, door frames, and modular office furniture. Posts, rails, fencing, metal gutters, highway and parking lot poles, guard rails, farm implements, garden tools and tractors, patio furniture, and other products used outdoors all benefit from the high weatherability factor of powder coating.

Countless everyday uses for powder coating include fire extinguishers, mechanical pencils and pens, thumbtacks, barbecue grills, and vending machines. Sporting goods equipment uses include bicycle frames, golf club shafts, ski poles, and exercise equipment. Technological advancements have allowed expansion of powder coating to nonmetal surfaces, such as ceramics, wood, plastic, and brass so that bottles, shower stalls, dashboards, and even toilet seats are now powder coated.

ENVIRONMENTAL IMPLICATIONS

With the current emphasis on control of emissions from industrial processes and overall concerns about air quality, ground water, and hazardous wastes, powder coatings offer an environmental advantage that may be a determining factor in selecting powder coating as a finishing process.

No solvents are involved in the mixing, application, or clean-up of a powder coating operation, virtually eliminating solvent emissions and the need for venting, filtering, or solvent recovery systems that would be required to control VOCs. This greatly simplifies the permitting process needed for installation, expansion, and operation of facilities, and makes compliance with federal and state regulations much easier. It also allows the possibility of including a finishing operation in a non-attainment area where other systems may not be permitted.

Most Powders Nonhazardous

In addition, the powders used for powder coatings are solids and most are classified as nonhazardous. Their use eliminates or minimizes problems and expenses associated with the disposal of hazardous wastes from a finishing process. There is no sludge, fouled spray booth filters, or solvent to contend with. Up to 99% of powder overspray can be recovered and reused, with automatic recycling units collecting the overspray powder and returning it directly to the feed hopper, where it returns to the system. In instances where there is waste, it can be handled as a non-water-soluble solid, presenting few disposal problems.

POWDER COATING GROWTH

Because of these and other advantages, powder coating system installations continue at a dramatic

rate. Development work on materials, equipment, and new applications and surfaces will bring dynamic changes to the powder coating industry. Applications not possible a few years ago may become practical and advantageous in the near future. The potential powder user should work closely with suppliers to stay current on the latest developments in powder coating materials, application, maintenance, and clean-up. And with continually changing environmental regulations, it is best to check with local officials for disposal recommendations.

The use of powder coating as a finishing process has grown rapidly over the last several years, with no signs of slowing down anytime soon. This manual will assist you in understanding the process, materials, and application methods of this ever-growing finishing technology.

CHAPTER 2

POWDER COATING MATERIALS

Powder coating materials are unique among all present-day compliance coatings. They are "dry," solid, essentially 100% film-forming coating materials, as opposed to the liquid materials used in high solids, water-reducible, radiation cure, and electrocoat technologies.

Powder coatings are, in fact, not *paint* until the coated item emerges from the curing or fusion oven. Prior to baking, powder coatings are finely pulverized plastic compositions, and consequently, most resins used in powder coatings are quite different from those used with liquid paints. Liquid paints require resins soluble or miscible with solvents and/or water, whereas powder coatings require resins that are solid materials. These solid resins must be solid at ambient, and reasonably elevated, storage temperatures, and must be capable of melting sharply to low viscosities to permit flow to a continuous coating film when heated.

In the early '70s the number of solid resin systems available to powder coatings manufacturers was somewhat restricted and, consequently, there were limitations on their ability to meet the diverse needs of the finishing industry. However, the growth of powder coatings has been accompanied by a rapid technological expansion, resulting in many new resin systems and other compositional components. This has now made available a wide range of powder coatings that will meet, and often exceed, the properties of most present-day solvent-based and water-based baking enamels.

Today, powder coatings are available to the industrial finisher in two major types, thermoplastics and thermosets. Like all other industrial surface coatings, powder coatings are individually formulated to meet the industrial user's very specific finishing needs. This means matching the finisher's house colors and film performance requirements, all within the particular restrictions of the finisher's operation. New types with unique properties are constantly being developed. Consequently, as with the selection of any industrial finish, a close relationship must be developed between the user of the coating and the supplier so that these exacting requirements are thoroughly understood, and the correct type of finishing material is supplied.

THERMOPLASTIC POWDER COATINGS

A thermoplastic powder coating melts and flows on the application of heat, but continues to have the same chemical composition when it solidifies on cooling. Thermoplastic powder coatings are based on thermoplastic resins of high molecular weight. The properties of these coatings depend on the basic properties of the resin. These tough and resistant resins tend to be difficult, as well as expensive, to be ground into the very fine particles necessary for the spray application and fusing of thin films. Consequently, thermoplastic resin systems are used more as functional coatings of many mils thickness and are applied mainly by the fluidized bed application technique.

Chapter 2

Typical examples of thermoplastic powder coatings are:

Polyethylene. Polyethylene powders were the first thermoplastic powder coatings offered to industry. Polyethylene provides coatings of excellent chemical resistance and toughness with outstanding electrical insulation properties. The surface of such applied coatings is smooth, warm to the touch, and of medium gloss. Polyethylene coatings have good release properties, allowing viscous sticky materials to be cleaned from their surfaces. Consequently, they find many uses in the coating of laboratory equipment.

Polypropylene. As a surface coating, polypropylene offers many of the useful properties it has as a plastic material. Because natural polypropylene is so inert, it shows little tendency to adhere to metal or other substrates. This characteristic makes it necessary to chemically modify the natural polypropylene when it is used as a surface coating powder, so that adhesion of the coating to the substrate can be obtained.

Nylon. Nylon powders are almost all based on type 11 nylon resin and offer tough coatings that have excellent abrasion, wear, and impact resistance with a low coefficient of friction when applied over a suitable primer. A most interesting use of nylon powder coating is in the field of mechanical design. Its unique combination of low coefficient of friction and good lubricity makes it ideal for sliding and rotating bearing applications such as automotive spline shafts, relay plungers, and shift forks, and other bearing surfaces on appliances, farm equipment, and textile machinery.

Polyvinyl. Polyvinyl chloride powder coatings have good exterior durability and provide coatings with a medium-soft glossy finish. They bond well to most metal substrates when applied over a suitable primer. These coatings will withstand the stress of metal fabrication operations such as bending, embossing, and drawing.

Thermoplastic. Thermoplastic polyester powder coatings have good adhesion to most

metal substrates without requiring a primer, and exhibit good exterior weatherability. They are good coatings for such items as outdoor metal furniture.

Thermoplastic powders are most suitable for coating items requiring a thicker film for extreme performance. They do not generally compete in the same markets as liquid paints.

THERMOSET POWDER COATINGS

Thermosetting powder coatings are quite different from thermoplastic powder coatings; they are based on lower molecular weight solid resins. Subjected to elevated temperatures, these coatings melt, flow, and chemically crosslink within themselves or with other reactive components to form a higher molecular weight reaction product. The coating has a different chemical structure than the basic resin. The newly formed materials are heat stable and will not soften back to a liquid on further exposure to heat. Powders based on these resin systems can be ground to fine particle sizes, in the range of 25-40 microns. Due to the rheological characteristics of these resin systems, they can produce thin paint-like surface coatings in the 1 to 3 mil (approximately .025 to .076 mm) range with properties equivalent and sometimes superior to the coatings produced by the liquid compliance technologies.

The generic types of resins used in thermosetting powder coatings are:

- Epoxy;
- Polyester;
- New polyester;
- Acrylic;
- Silicone/Epoxy;
- Silicone acrylics; and
- Silicone.

In the area of thermosetting powder coatings, a large technological expansion has occurred in the last few years. Quite often more than one generic type of powder coating can be custom formulated to meet a specific end use. The final choice, of course, depends on economics and performance, and must be arrived at through cooperation between the powder supplier and the user.

Epoxy Resin Based Systems

Epoxy powders are a prominent type of thermosetting powder coating in use today, due to their very wide range of formulation latitude. Epoxy powders are used for both thick-film functional end uses and thin-film decorative uses. Crosslinking systems are similar to those used for epoxy adhesives or two-part epoxy paints, except most are designed to be stable at room temperatures.

Functional Epoxy Powder Coatings

Two major functional end uses for epoxies are in electrical insulation and corrosion protection. In the insulation use, epoxy powders conform exactly to the contours of the electrical part, bonding to the surface of the part to become a permanent integral insulation that is void-free and of low bulk. Typical applications would be on automobile alternators, electric motors, and switch gear. In the area of corrosion protection, epoxy powders provide low-cost, low-maintenance, and long-lasting protection against most chemically aggressive environments. They are, therefore, suitable for coating gas and oil field distribution piping. Recently, multifunctional epoxies have been used to make high temperature and pressure-resistant coatings for lining the inside of "down-hole" oil drilling pipes. Similarly, epoxy powder coated "rebars"—reinforcing steel bars for highway and bridge decks—drastically cut the formation of corrosion products that cause concrete cracking and heavy repair costs. Because of application needs, functional epoxies are often very fast curing and may require cool storage and shipment.

Thin-film Epoxy Powder Coatings

In the thin-film surface coating area, i.e., in the 1 to 3 mil (approximately .025 to .076 mm) range, epoxy powders are formulated to produce highly attractive coatings of various gloss or surface textures, while still retaining the inherent toughness, corrosion resistance, flexibility, and adhesion characteristic of the epoxy resin family. Recent advances in epoxy crosslinking chemistry have given formulators a wide range of film properties within this area. The range of bake time and temperature has been especially broadened. Epoxies are now available that can be baked at a temperature as low as 250°F (121°C) for a period of 20 to 30 minutes, or for a very short time at much higher temperatures. A good example of this is the application of epoxy powder coating to screen wire, where a good combination of fast cure and thin film forming ability is required.

Despite having an excellent combination of mechanical and resistance properties, epoxy does have one major disadvantage—poor exterior weatherability. An epoxy will exhibit rapid chalking within a few months of exterior exposure, just as a liquid epoxy coating does. Although a weathered epoxy coating may look unsightly, it still maintains its mechanical and resistance properties.

Therefore, decorative epoxy powder coatings are restricted to internal uses or areas of very little UV exposure. This still leaves a number of possible application areas for epoxy powder coatings. Because of their combination of toughness and resistance properties, epoxy powders are finding many uses in the major appliance industry. For example, in some applications white epoxy powder coatings have replaced porcelain on refrigerator interiors, providing advantages and cost savings. The advantages come in the freedom from cracking, a characteristic displayed by porcelain when handled roughly.

There is also a cost savings in the type of substrate that can be used in the liner construc-

Chapter 2

tion. Porcelain requires low-carbon steel, which must be thoroughly pickled through as many as 14 stages. Powder coating can use iron or zinc phosphated cold-rolled steel. Since porcelain must be fired at temperatures around 1500°F (816°C) and thermosetting epoxy powders normally bake at about 375°F (191°C) temperature range, considerable energy savings are obtained. Other areas of epoxy powder use in the appliance industry include the interior coating of dryer drums and microwave oven cavities. Similarly, the properties of epoxy powder coatings make them very suitable for automotive parts such as oil filters, springs, and other components where exterior durability is not a prime requisite. Typical applications and general properties of epoxy are listed in Figures 2-1 and 2-2.

Epoxy Polyester Hybrids

Epoxy powder coatings based on newer technology are known as epoxy-polyester “hybrids” or “multipolymer” systems.

This group of powder coatings could be considered simply part of the epoxy family, except that the high percentage of polyester utilized (often more than half the resin) makes

Fire extinguishers	Shelving
Toys	Transformer cases
Refrigerator liners	Primers
Dryer drums	Bathroom fixtures
Microwave ovens	Refrigerator racks
Mixers and blenders	Sweepers
Fertilizer spreaders	Sewing machines
Screening	Power Tools
Oil filters	Room air conditioners
Automobile springs	Office furniture
Hospital equipment	Instrument cases
Bus seat frames	Garden tools
Business machines	Kitchen furniture
Glass bottles	

Figure 2-1. Typical applications of epoxy.

that classification misleading. The properties of these hybrid coatings are more closely akin to epoxies than polyesters, with a few notable exceptions. They show similar flexibility in terms of impact and bend resistance, but produce slightly softer films. Their corrosion resistance is comparable to epoxies in many cases, but their resistance to solvents and alkali is generally inferior to pure epoxies.

One advantage of these hybrids, due to the influences of the polyester component, is high

<u>Property</u>	<u>Range</u>
Hardness (pencil)	HB-7H
Impact resistance (in-lb)	60-160
Gloss (60 deg. meter)	3-100+
Color	All colors, clear and textures
Salt spray	1,000+ hr obtainable*
Condensing humidity	1,000+ hr obtainable*
Cure range (typical 2 mil (0.05mm) film—time @ metal temp.)	3 min @ 450°F (232°C) 25 min @ 250°F (121°C)
*Environmental resistance properties are a function of the total coating process, including substrate and pretreatment quality.	

Figure 2-2. Typical properties of epoxy.

resistance to overbake yellowing in the cure oven. This also translates into some improved resistance to ultraviolet light yellowing. These systems will begin to chalk almost as fast as an epoxy but, after initial chalking, the deterioration is slower and the discoloration less severe than for unmodified epoxy powders.

Another advantage of epoxy/polyester powder coatings is their good electrostatic spray characteristics. They can be applied with excellent transfer efficiency and show good penetration into corners and recesses.

An epoxy polyester hybrid should certainly be considered along with the epoxy family for thin film decorative end use. Applications for an epoxy polyester hybrid are listed in Figure 2-3; typical properties are listed in Figure 2-4.

**POLYESTER RESIN-BASED
POWDER COATINGS**

The polyester powder coatings used commercially in the United States are divided into two types (with various curing mechanisms): hydroxyl polyester powders and carboxyl polyester powders.

Toolboxes	Oil filters and air cleaners
Farm equipment	Fire extinguishers
Air conditioner housings	Transformer covers
Electrical control boxes	Toys
Hot water heaters	Screening wire
Hot water radiators	Power tools
Primer/surfacers	Shelving
Grain storage bins	Office furniture

Figure 2-3. Applications of an epoxy polyester hybrid.

**Hydroxyl or Urethane Polyester
Powder Coatings**

The primary type, in use for a number of years, is a urethane-cured polyester powder that is comparable chemically to the exterior quality urethane paints used on aircraft, buses, trucks, and railroad cars. Coatings of this type combine outstanding thin film appearance and toughness, with excellent weathering properties.

<u>Property</u>	<u>Range</u>
Hardness (pencil)	HB-3H
Impact resistance (in-lb)	60-160
Gloss (60 deg. meter)	10-100+
Color	All colors, clear and textures
Salt spray	1,000+ hr obtainable*
Condensing humidity	1,000+ hr obtainable*
Cure range (typical 2 mil (0.05 mm) film—time @ metal temp.)	10 min @ 400°F (204°C) 25 min @ 300°F (149°C)
*Environmental resistance properties are a function of the total coating process, including substrate and pretreatment quality.	

Figure 2.4. Typical properties of an epoxy polyester hybrid.

Chapter 2

Typical curing times for these types of systems are 20 minutes at 375°F (191°C) to 10 minutes at 400°F (204°C). This is another area of thermosetting powder coating chemistry that has expanded greatly in the past few years, and recent developments in the area of cure chemistry have made it possible to develop good film properties at temperatures as low as 320°F (160°C) for 20 minutes. However, care should be exercised to assure that vital properties, such as hardness and weatherability, are maintained.

The urethane chemistry of these systems lends itself to good performance in the thinner 1 to 2 mil (0.25 to .05 mm) film thickness range. Thicker films tend to exhibit poorer mechanical properties in such factors as impact resistance and flexibility. These polyesters are true competitors to high-quality liquid paints in respect to thin-film appearance. They have found many uses in the automotive, appliance, and general metal finishing areas.

Many of these systems have an emission during the cure of 1 to 5% by weight of e-caprolactam, which must be vented from the bake oven to prevent fouling or appearance contamination.

One major use of these polyesters is in the coating of lighting fixtures where excellent reflectivity is required at a minimal film thick-

Auomotive trim parts	Garden tractors
Fluorescent light fixtures	Range side panels and broiler
Steel and aluminum wheels	Ornamental iron
Patio furniture	Air conditioner cabinets
Playground equipment	Restaurant furniture supports
Chrome wheels and trim	Fence fittings
	Transformer cases

Figure 2-5. Typical applications for urethane polyester powder.

ness. Other areas of use include office furniture, wheels, boat trailers, garden tractors, and many others requiring exterior durability. In the appliance industry, they are used as a porcelain replacement on range side panels and meet all the requirements of this industry's exterior finishing specifications. Urethane polyester powder applications are listed in Figure 2-5; typical properties are given in Figure 2-6.

Carboxyl Polyester Powders

The second type of polyester powder, carboxyl (COOH) polyester powder, is based on technology developed in Europe. These products can be described as the exterior durable cousins of the

<u>Property</u>	<u>Range</u>
Hardness (pencil)	HB-6H
Impact resistance (in-lb)	20-160
Gloss (60 deg. meter)	5-95+
Colors	All colors, clear and textures
Salt spray	1,000+ hr obtainable*
Condensing humidity	1,000+ hr obtainable*
Cure range (typical 1-2 mil (0.25-0.5 mm) @ metal temp.)	10 min @ 400°F (204°C) 20 min @ 320°F (160°C)
*Environmental resistance properties are a function of the total coating process, including substrate and pretreatment quality.	

Figure 2-6. Typical properties of urethane polyester powder.

epoxy/polyester hybrids but, instead of using a conventional epoxy resin to co-react with the polyester, a very low molecular weight glycidyl or epoxy functional curing agent is used. In this way, the polyester constitutes a very high percentage of the resin and provides weathering comparable to urethane-cured polyesters.

These coatings are typically baked for 3 to 15 minutes at 350 to 400°F (177 to 204°C), but more recent formulations give cures as low as 300°F (149°C) for extended time periods. This could be an advantage over the urethane-cure polyesters in certain applications. The primary attributes of this type of polyester are their excellent mechanical properties at any film thickness and good edge coverage. Films of 3 to 5 mils offer excellent flow, gloss, and toughness. The appearance of these systems in the 1 to 2 mil (0.25 to 0.05 mm) range may be a little more textured than the urethane-cured polyesters but, again, advancement in this area is narrowing the difference. Overbake color stability is also excellent. Adhesion and corrosion resistance properties are comparable to the urethane-cured polyesters, but their resistance to chemicals and solvents is lower.

An ideal application for this type of polyester powder is the coating of air conditioner cabinets,

where a combination of good sharp-edge coverage with good exterior durability is required on the venting components. Typical applications of carboxyl polyester powders are listed in Figure 2-7, and typical properties in Figure 2-8.

New Polyester Powders

Now entering the marketplace are polyester powder coatings based on new crosslinking chemistries. They are endowed with excellent mechanical properties such as high film thickness, good edge coverage, and dielectric resistance. Their appearance and properties are similar to TGIC (carboxyl) polyesters. This type of polyester powder is ideally suited for coating air conditioner cabinets, transformers, and precoated

Irrigation pipe and fixtures	Fence poles and fittings
Outdoor furniture	Lawn and garden equipment
Air conditioning units	Aluminum extrusions
Steel and aluminum wheels	Transformers
Any post-forming application requiring weatherability	Wire fencing

Figure 2-7. Typical applications of carboxyl polyester powders

<u>Property</u>	<u>Range</u>
Hardness (pencil)	HB-6H
Impact (in-lb)	60-160
Gloss (60 deg. meter)	5-95+
Colors	All colors, clear and textures
Salt spray	1,000+ hr obtainable*
Condensing humidity	1,000+ hr obtainable*
Cure range (typical 2-3 mil (0.07-0.5 mm), time @ metal temp.)	3-10 min @ 400°F (204°C) 30 min @ 300°F (149°C)

*Environmental resistance properties are a function of the total coating process, including substrate and pretreatment quality.

Figure 2-8. Typical properties of carboxyl polyester powders

Chapter 2

Air conditioning units	Farm equipment
Wire fencing	Aluminum extrusions
Transformers	
Appliances—precoated metals	

Figure 2-9. Typical applications of new polyester powders.

metals. Typical applications are listed in Figure 2-9. Properties are listed in Figure 2-10.

Acrylic Powders

Acrylics constitute another generic group of thermosetting powder coatings with exterior durability. In the early days of powder coating,

makes them excellent candidates for the appliance industry where they are used quite extensively.

The acrylics show good resistance to alkali, an important trait for use on appliances. On range sides, for example, they may come into contact with alkali oven-cleaning compounds, or on washing machine parts they may be contacted by hot detergent. These systems also demonstrate extremely good electrostatic spray properties, making the application of thin film thickness very realistic and controllable. As a class, acrylics are more sensitive to substrate quality than other thermoset powder coatings, and most acrylics are not compatible with other coating chemistries. Typical applications are listed in Figure 2-11; properties are given in Figure 2-12.

<u>Property</u>	<u>Range</u>
Hardness (pencil)	F-2H
Impact (in-lb)	60-160
Gloss (60°)	20-90
Color	All colors, clear and textures
Salt spray	1,000+ hr
Condensing humidity	1,000+ hr
Cure range, time @ metal temp.	10 min @ 400°F (204°C) 30 min @ 375°F (191°C)

Figure 2-10. Typical properties of new polyester powders.

imported acrylics established a good reputation for exterior durability combined with trouble-free application characteristics. Major acrylic powder coatings sold in the U.S. are the urethane-cured and glycidyl, or epoxy functional, types.

Urethane acrylics require bake temperatures similar to the hydroxyl polyester urethanes with a minimum cure temperature around 340°F (171°C). They are also characterized by excellent thin film appearance and, unlike liquid acrylic paints, retain a level of film flexibility for impact resistance with excellent film hardness. This

Glycidyl (GMA) acrylics require bake temperatures with a minimum cure temperature around 300°F (149°C). They have excellent thin film appearance and offer excellent film flexibility in the form of impact resistance.

Range side panels	Aluminum extrusions
Refrigerator cabinets and doors	Microwave ovens
Dishwasher exteriors	Garden tractors
Automotive trim coating	Washing machine parts

Figure 2-11. Typical applications of acrylics.

<u>Property</u>	<u>Range</u>
Hardness (pencil)	2-3H
Impact resistance (in-lb)	40-100
Gloss	10-90
Color	All colors, clear and textures
Salt spray	1,000+ hr*
Condensing humidity	1,000+ hr*
Cure range (typical 1.5 mil (0.0381 mm) film time @ metal temp.)	10 min @ 400°F (204°C) 25 min @ 350°F (177°C)

*Environmental resistance properties are a function of the total coating process including substrate and pretreatment quality.

Figure 2-12. Typical properties of acrylics.

Glycidyl acrylics make the most water-white clear powder coatings, and are used for various automotive and hardware applications. Typical applications are listed in Figure 2-13 and properties in Figure 2-14.

Silicone Powders and Modified Silicone Powders

A recently introduced class of silicone powder coating material can withstand operating temperatures from 400°F (204°C) to over 1,000°F (538°C) and has found applications in areas from food contact cookware to engine exhaust systems. Typical properties of the new silicone powders are listed in Figure 2-15.

COATING SELECTION

Industrial finishes are custom formulated to individual and end-user requirements. Successful selection depends on a close working relationship between users and suppliers. Selection should be strictly on a demonstrated film performance basis. This is because the film performance of a thermosetting powder coating is completely dependent on the bake it receives in a particular plant, on a particular substrate, with a particular degree of

cleanliness, and type of metal pretreatment. Many specialties in the marketplace can cross over the guidelines. Because of the mushrooming effect of this technology, areas of formulation expertise are developing that can stretch some of the characteristics of a particular generic type, making it perhaps a more economically viable alternate under specific plant circumstances.

A summary of the key properties of each generic type of thermosetting powder coating is presented in Figure 2-16.

In selecting a thermosetting powder type, such key factors as demonstrated film performance, demonstrated application characteristics, and cost performance balance should be kept in focus

SAFETY

No matter which coating is selected for a particular application, the health and safety aspects of the actual fully formulated and color-matched material to be used must be fully determined. This information should be requested from the supplier since it can be of great significance to the final application.

Chapter 2

Automotive trim coatings
Clear coating for aluminum wheels
Motorcycles
Automotive prime surfaces

Figure 2-13. Typical applications of GMA acrylics.

<u>Property</u>	<u>Range</u>
Hardness	H-2H
Impact resistance	60-160
Gloss	10-95+
Colors	All colors, clear and textures
Salt spray	1,000+ hr
Condensing humidity	1,000+ hr
Cure range, time @ metal temp.	5 min @ 400°F (204°C) 25 min @ 300°F (149°C)

Figure 2-14. Typical properties of GMA acrylics.

<u>Property</u>	<u>Range</u>
Hardness	H-5H
Direct impact	20 in/lbs
Gloss	10-85
Colors	Black and other colors depending on system
Cure schedule	15 min @ 440 to 500°F (204 to 260°C)
Operating temperatures	400 to >1000°F (204 to >538°C) (Type of substrate is critical)
Can be formulated to comply with FDA 175.300 requirements.	

Figure 2-15. Typical properties of the new silicone powders.

Epoxy	Tough and flexible. Excellent chemical and corrosion resistance. Excellent mechanical properties. Poor exterior color/gloss retention.
Epoxy Polyester Hybrids	Decorative film performance. Very good chemical and corrosion resistance. Very good mechanical properties. Fair exterior color/gloss retention.
Polyester (Hydroxyl) Urethane	Thin film powder applications. Good chemical and corrosion resistance. Good mechanical properties. Very good exterior color/gloss retention.
TGIC (Carboxyl) Polyester	Thicker film powder applications. Very good chemical and corrosion resistance. Excellent mechanical properties. Very good exterior color/gloss retention.
New Polyester	Very good chemical and corrosion resistance. Excellent mechanical properties. Very good exterior color/gloss retention.
Acrylic Urethane	Thin film powder coatings. Good chemical and corrosion resistance. Poor mechanical properties. Excellent exterior color/gloss retention.
Acrylic Hybrids	Decorative film performance. Very good chemical and corrosion resistance. Good mechanical properties. Fair to good exterior color/gloss retention.
GMA Acrylic	Thin film powder coatings. Good chemical and corrosion resistance. Good mechanical properties. Excellent exterior color/gloss retention.
Silicone Epoxy Silicone Acrylic Silicone	Operating temperatures from 400° to >1000°F (204 to >538°C). Can be formulated to fit FDA 175.300 applications.

Figure 2-16. Key properties of thermosetting powder coatings.

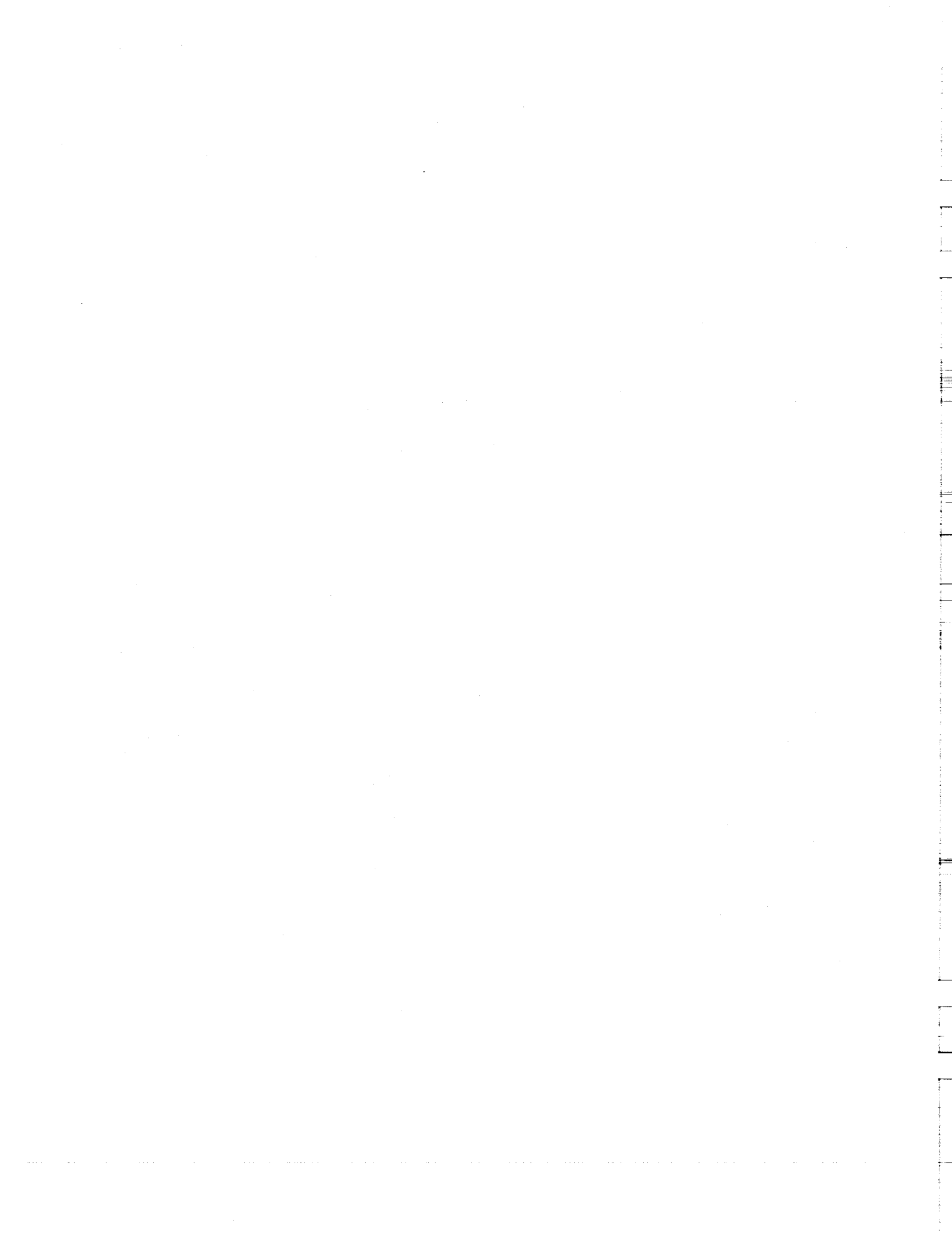

CHAPTER 3

ECONOMIC ADVANTAGES OF POWDER COATING

Energy and labor cost reduction, high operating efficiencies, and environmental safety are advantages of powder coating that attract more and more finishers. Great cost savings can be found in each of these areas.

When compared with a liquid coating system, a powder coating system has several obvious significant economic advantages. There are also many advantages that may not appear significant by themselves but, when collectively considered, contribute substantial cost savings. Although this chapter will try to cover all cost advantages of powder coating, each individual application must be analyzed in light of its particular needs, and appropriate cost advantages must be adapted to that situation.

COST SAVINGS

The specific areas covered relative to the economic advantages of powder coating systems are: energy savings, labor cost savings, higher operating efficiencies, environmental factors, plant safety, and capital costs.

Energy Savings

One of the most significant advantages of powder coating is that it does not require special air makeup to the coating booth. Since powder contains no compounds that are volatile at room temperature, air makeup for the booth can be recirculated to the plant—quite advantageous to a plant where extreme weather conditions are prevalent. The cost of heating booth makeup air is a sizeable figure in most coating operations,

and considerable savings result if it can be avoided.

Another significant economic advantage of powder coating is the minimal amount of oven ventilation necessary versus the amount needed for all forms of liquid coatings, including waterborne, high solids, and electrocoating. N.F.P.A. 86-A requires that 10,000 SCF of air be exhausted from the oven for each gallon of solvent load; the N.F.P.A. recommends that only 1,500 SCF of air be exhausted for each pound of volatiles in sprayed powder. Generally, the amount of volatiles in powder is minimal. Since this amount will vary from powder to powder, a user should look critically at this factor in any potential use analysis.

Labor Savings

The labor cost savings of powder coating depends on the individual finisher's requirements; however, there are definite potential labor savings to be considered. When the powder is delivered to a user's plant, it is ready to use; no need to mix any solvents or catalysts prior to application, as is necessary for many liquid coatings. Once the application process is operating, there are no critical operating parameters to maintain, such as viscosity and pH, as is the case for many liquid coatings. Nor are there percent solids, specific resistance, binder to pigment ratio, and MEQ levels, which are necessary for electrocoating systems. The level of skill and training required of an operator for a powder coating system is less than that needed for liquid systems, and significantly less than for electrocoat systems.

Chapter 3

There also may be labor savings because better overall coverage can be obtained with automatic powder coating equipment. Often less, or no, manual reinforcement is required. This depends largely on production requirements and part configuration, but is a factor to be considered.

High Operating Efficiencies

Economic advantages resulting from higher operating efficiencies are many and varied, depending upon the particular operation. The most significant advantage is the material usage efficiency. Fluidized bed operations are inherently 100% efficient, although some loss may result from such items as dragout and excess film. Electrostatic spray operations are usually considered to be between 50 and 80% efficient upon first use of the powder. That is, from 20 to 50% of the material is oversprayed and, if collected, can be reused as satisfactory powder. Since oversprayed powder can be reclaimed during the application process and therefore reused, overall material utilization in the range of 95 to 98% can be achieved. By comparison, liquid spray coating systems can achieve material usage efficiencies only in the range of 20 to 90%. With electrocoating, 98 to 99% efficiency is possible.

Since powder greatly reduces drip, run, or sag, a significantly lower reject rate can be achieved. If badly sprayed parts are discovered prior to curing, they can be simply blown clean with an air gun, and then recoated. Since there is no flash-off time required when using powder coatings, a finisher can use the saved plant space more efficiently and economically. In addition, there is less chance of particulate and dust contamination, which could take place during the flash-off period. This results in fewer rejects for the powder coating product.

Powder coating can achieve equal or superior film properties compared with liquid coatings—in most cases with only one coat, eliminating the need to prime a part prior to topcoating.

In addition, since powder coatings develop full cure during the baking cycle, and usually resist

abuse better than liquid coatings upon leaving the oven, less damage will result during the handling, assembling, and packaging operations. This decreases the need for touch-up and, again, the reject rate will be lower. Both items contribute to savings.

Finally, the amount of space required to store powder, and the space occupied by the powder coating system itself, is considerably less, in most cases, than the space required for an equivalent liquid coating system. This allows more productive and efficient use of available plant space.

Capital Costs

Capital costs associated with installing a powder coating system are becoming more competitive with a liquid coating system. They are well below those required for an electrocoating system. There is also an additional cost for the laboratory equipment necessary for maintaining an electrocoat tank. In many cases, finishers are experiencing a one-year or less payback period after installing their powder coating system.

ENVIRONMENTAL FACTORS

In some cases, it may be more difficult to put a dollar figure on the economic advantages of powder coating when considering the environmental factors. However, there are significant factors that can be readily measured. Since there are effectively no solvents in powder coating, and as much as 70% of various solvents in a conventional coating, powder coating can achieve an environmentally "clean" finishing line.

As regulatory agencies further limit the amount of solvent emissions allowed, more and more finishers using liquid coatings systems must install costly afterburners to incinerate the emitted solvents. In almost every case, a solvent only adds to the cost and detracts from the properties of a cured coating. Another significant environmental factor is the increased difficulty and cost of disposing of the hazardous waste generated by liquid coating application. In some cases it is

Economic Advantages of Powder Coating

nearly impossible and is a responsibility that lingers for years.

PLANT SAFETY

Consider the economic advantages of powder coatings in conjunction with plant safety. Since there are effectively no solvents in a powder coating, the significant reduction in fire risk could reduce a plant's insurance premiums considerably. In addition, any spillage of powder outside the coating booth can be safely and easily removed by an industrial vacuum cleaner fitted with an air-driven or dust-tight electric motor. There is also a reduced health hazard to the operator in a powder coating system, since there are no solvents to cause nose, mouth, throat, skin, or eye irritations.

There have been rare cases where a powder caused skin irritation. Powders can be abrasive by continued contact with contaminated clothing or gloves, and proper care should be taken. Problems can be avoided by washing with soap and water. The improved worker environment can result in lower employee absenteeism, which could be a significant economic advantage.

APPLICATION EVALUATION

Many published articles give cost justifications for powder with comparisons to liquid. The most important figure in such evaluations is the net cost per square foot or per item to successfully coat the product with a suitable finish.

When considering costs, the entire finishing system, starting at the entrance area and including

everything that adds cost to the manufacturer throughout the expected life of the product, must be considered. This should include items returned and product liability.

These are some of the basic requirements to finish a part:

1. Space and equipment for cleaning, pretreat, application, curing.
2. Manpower.
3. Coating material and supplies.
4. Energy washing, drying, spraybooth and oven makeup air, curing oven.
5. Waste disposal.
6. Rejected parts due to finish, i.e., runs, sags, scratches, and other damage to the finish.

There are many economic advantages of powder coating that should be considered when preparing a justification for a powder system. The individual requirements and needs for each application will put a different emphasis on every considered area, be it energy, labor, operating efficiency, environment, or safety. It is not practical in this presentation to cover specific costs for any single installation. The matter can, however, be treated in a rather general way. The following pages include a cost comparison worksheet and several related tables.

The examples on the following four pages were originally developed by Morton Powder Coatings Group of Reading, Pennsylvania, and have been adapted for this volume by G. Bruce Bryan of Volstatic, Incorporated. These cost figures are a guide, since actual costs change frequently. Specific costs can be inserted as required.

Chapter 3

LINE #	VARIABLE	EXPLANATION	HIGH SOLIDS LIQUID	POWDER EXAMPLE	EXISTING METHOD	POWDER
1	Paint Cost	Liquid \$ Per Gal (reduced) Powder \$ Per Pound	21.00	2.40		
2	Volume Solids %	Reduced	54%	98%		
3	Specific Gravity	Powder Only		1.6		
4	Theoretical Coverage Ft ² /# @ 100%	Liquid - Line 2 X 1604 Powder - 192.4 / Line 3	866	118		
5	% Material Utilization	See Table 3-1 Below	80%	95%		
6	Film Thickness Mils	Average Film Thickness	1.2	1.5		
7	Actual Coverage Ft ² /# or Gal.	Line 4 / Line 6 X Line 5	577	75		
8	Applied Cost \$/Ft ²	Line 1 / Line 7	.0364	.0320		

Figure 3-1. Applied Material Cost.

Table 3-1
Material Utilization

System % Utilization Efficiency	Conventional Liquid	Electrostatic Liquid	Disc. or Bell Liquid	Electrostatic Powder
	40	50-70	80-90	95-98

LINE #	VARIABLE	EXPLANATION	HIGH SOLIDS LIQUID	POWDER EXAMPLE	EXISTING METHOD	POWDER
9	Booth Openings Ft ²	Square Footage of Booth Openings	208	60		
10	Face Velocity Ft/Min	Minimum Average Velocity is 100 Ft/Min, 125 Ft/Min Recommended	125	133		
11	CFM Exhausted Ft ³ /Min	Line 9 X Line 10	26,000	Returned to Plant		
12	Air Temperature °F	See Table 3-3 Yearly Average Temperature	50 °F	50 °F		
13	Plant Air Temperature °F	Average Plant Air Temp. During Winter Months	70 °F	70 °F		
14	Temperature Difference °F	Line 12 - Line 13	20 °F	20 °F		
15	BTU Required BTU ^s	Line 11 X Line 14 X 1.1* BTUs/Hour @ 100% Effic.	572,000	0		

*The constant 1.1 is found by multiplying .018 (BTU^s required to raise one cubic foot of air one degree F. @ 100% efficiency) by 60 (converting CFM to CFH). 1.08 is rounded to 1.1.

Figure 3-2. Exhaust - spray booth.

Economic Advantages of Powder Coating

LINE #	VARIABLE	EXPLANATION	HIGH SOLIDS LIQUID	POWDER EXAMPLE	EXISTING METHOD	POWDER
16	Production Ft ² /Hr	Number of Parts Per Hour X Part Surface Area	6,000	6,000		
17	Coverage Ft ² /# or Gal	Line 7	577	75		
18	Applied Coating # or	Line 16 / Line 17	10.4	80		
19	Solvent Load Gal or #/Hr	(100% - Line 2) X Line 18	4.8	1.6		
20	Exhaust Required CFM	Liquid - Line 19 X 167.0(a) Powder - Line 19 X 250.0(b) (Minimum 600 CFM)	801.6	600		
21	Bake Temperature °F	Recommended Cure Temp.	325 °F	375 °F		
22	Plant Temp. °F	Line 13	70 °F	70 °F		
23	Temp. Difference °F	Line 21 - Line 22	255 °F	305 °F		
24	BTUs Required	Line 20 X Line 23 X 1.1*	224,850	201,300		

(a) 167 = 10,000 SCF (NFPA Recommended) X 1 Hr /60 Min Liquid
(b) 250 = 1,500 SCF (HFA Recommended) X 1 Hr /60 Min Powder

* The constant 1.1 is found by multiplying .018 BTUs required to raise one cubic foot of air one degree F @ 100% efficiency) by 60 (converting CFM to CFH). 1.08 is rounded to 1.1.

Figure 3-3. Exhaust - bake oven.

LINE #	VARIABLE	EXPLANATION	HIGH SOLIDS LIQUID	POWDER EXAMPLE	EXISTING METHOD	POWDER
25	Temp. Difference °F	Line 23	255 °F	305 °F		
26	Conveyor & Tooling Load #/Hr	(Conveyor Wt./Ft. + Hanger & Hook Wt./Ft.) X Conveyor Speed X 60	5,760	5,760		
27	Ware Load #/Hr	Line 16 X Ware #/Ft ²	3,600	3,600		
28	Total Load #/Hr	Line 26 + Line 27	9,360	9,360		
29	Specific Heat Load	Use: Steel .125, Iron .13, Aluminum .248	.125	.125		
30	Total Load Loss BTU/Hr	Line 25 X Line 28 X Line 29	298,350	356,850		
31	Radiation Loss BTU/Hr	Total Oven Surface Area (Ft ²) X 3+ X Line 25 (If outside Use Line 12)	1,517,760	1,815,360		
32	Total Heat Loss BTU/Hr	Line 30 + Line 31	1,816,110	2,172,210		

BTU loss per ft²/hour with 4" insulation

Figure 3-4. Conveyor and part heat loss.

Chapter 3

LINE #	VARIABLE	EXPLANATION	HIGH SOLIDS LIQUID	POWDER EXAMPLE	EXISTING METHOD	POWDER
33	Exhaust-Spray Booth BTUs/Hr	Line 15	572,000	0		
34	Exhaust-Bake Oven BTUs/Hr	Line 24	224,850	201,300		
35	Conveyor & Part Heat Loss BTUs/Hr	Line 32	1,816,010	2,172,210		
36	Oven Make-Up BTUs/Hr	Line 20 X Line 14 X 1.1*	17,635	13,200		
37	Total BTUs BTUs/Hr	Line 33 + Line 34 + Line 35 + Line 36	2,630,595	2,386,710		
38	Energy Cost - Gas \$/Hr	(Line 37/(1,000,000))/Table 3-2 X Cost/1,000,000 Cubic Ft.	19.73	17.90		
39	Energy Cost - Elec. \$/Hr	(Line 37/3,415)/Table 3-2 X Cost/KWH				

Figure 3-5. Total energy cost.

Table 3-2
Fuel Efficiency

FUEL	COAL	OIL	ELECTRICITY	GAS DIRECT FIRE	GAS INDIRECT FIRE
	HEAT CONTENT %	HEAT CONTENT %	HEAT CONTENT %	HEAT CONTENT %	HEAT CONTENT %
Efficiency	2,400,000 BTU/Ton 50	142,000 BTU/Ton 75	3,415 BTU/KWH 75	100,000 BTU/Therm 90	100,000 TRU/Therm 80

LINE #	VARIABLE	EXPLANATION	HIGH SOLIDS LIQUID	POWDER EXAMPLE	EXISTING METHOD	POWDER
40	Labor Costs w/Fringe \$/Hr	A - Supervision B - Paint Mix C - Painters-Liquid(2 operators) D - Painters-Powder(2 operators)	15.00 12.00 27.00	15.00 27.00		
41	Total Operator Labor \$/Hr	Total of Line 40	54.00	42.00		
42	Clean-Up Cost \$/Hr	(Clean-up Man-Hours Per Shift X Labor \$/Hr) / Operating Hrs /Shift	1.72	.60		
43	Available Sludge Gal. or #/Hr	Line 18 X (1.0 - Line 5) X Line 2	1.12	3.92		
44	Sludge Cost \$/Hr	Line 43 X Disposal Cost/Gal or #	4.23	N.A.		
45	Maintenance Cost \$/Hr	(Maint. Hrs /Yr X Maint. \$/Hr.) + Yearly Replacement Parts Costs + Op. Hrs /Yr	5.92	2.53		
46	Filter Cost \$/Hr	(Filter Cost X # of Filters Per Year) + Operating Hrs /Yr	.96	N.A.		
47	Labor & Maintenance \$/Hr	Line 41 + Line 42 + Line 44 + Line 45 + Line 46	66.83	45.13		

Figure 3-6. Labor and maintenance costs.

Economic Advantages of Powder Coating

VARIABLE	HIGH SOLIDS LIQUID	POWDER EXAMPLE	EXISTING METHOD	POWDER
Material Costs - Line 8 X Line 16 X Operating Hrs/Yr	\$425,880	\$374,400		
Energy Costs - Line 38 X Operating Hrs/Yr	\$38,474	\$34,905		
Labor & Maintenance Costs - Line 47 X Operating Hrs/Yr	\$130,319	\$88,004		
Total Operating Costs	\$594,673	\$497,309		
Annualized Cost/Ft ² Total Operating Costs / (Line 16 X Operating Hrs/Yr)	\$.0508	\$.0425		

Figure 3-7. Cost summary: Annualized dollars.

Depreciation

Energy Credits

Tax Credits

Reject/Rework Costs

Safety Costs

Health Consideration Costs

Figure 3-8. Other costs to consider.

Table 3-3
Average Temperature
(Canadian cities are in degrees Celsius)

LOCATION	AVG.*	LOCATION	AVG.*
Albany, NY	48	Memphis, TN	62
Albuquerque, NM	55	Miami, FL	75
Atlanta, GA	62	Milwaukee, WI	48
Baltimore, MD	56	Minneapolis, MN	45
Bismarck, ND	41	Mobile, AL	68
Boston, MA	50	Montreal, Que.	7
Buffalo, NY	47	Nashville, TN	60
Burlington, VT	45	New Orleans, LA	70
Calgary, Alta.	4	New York, NY	52
Cheyenne, WY	45	Oklahoma City, OK	60
Chicago, IL	50	Omaha, NE	51
Cleveland, OH	49	Philadelphia, PA	54
Columbia, SC	64	Phoenix, AZ	70
Concord, NH	44	Portland, ME	46
Dallas, TX	66	Providence, RI	50
Denver, CO	50	Quebec, Que.	5
Des Moines, IA	50	Rapid City, SD	47
Detroit, MI	49	Reno, NV	50
Great Falls, MT	46	Richmond, VA	58
Hartford, CT	50	St. Louis, MO	50
Honolulu, HI	75	Salt Lake City, UT	51
Houston, TX	69	San Francisco, CA	56
Indianapolis, IN	53	Seattle, WA	52
Jacksonville, FL	69	Toronto, Ont.	8
Juneau, AK	42	Vancouver, B.C.	11
Kansas City, MO	55	Washington, DC	56
Little Rock, AR	62	Wichita, KS	57
Los Angeles, CA	63	Winnipeg, Man.	3
Louisville, KY	57		

* Source: Weather Bureau/Department of Commerce

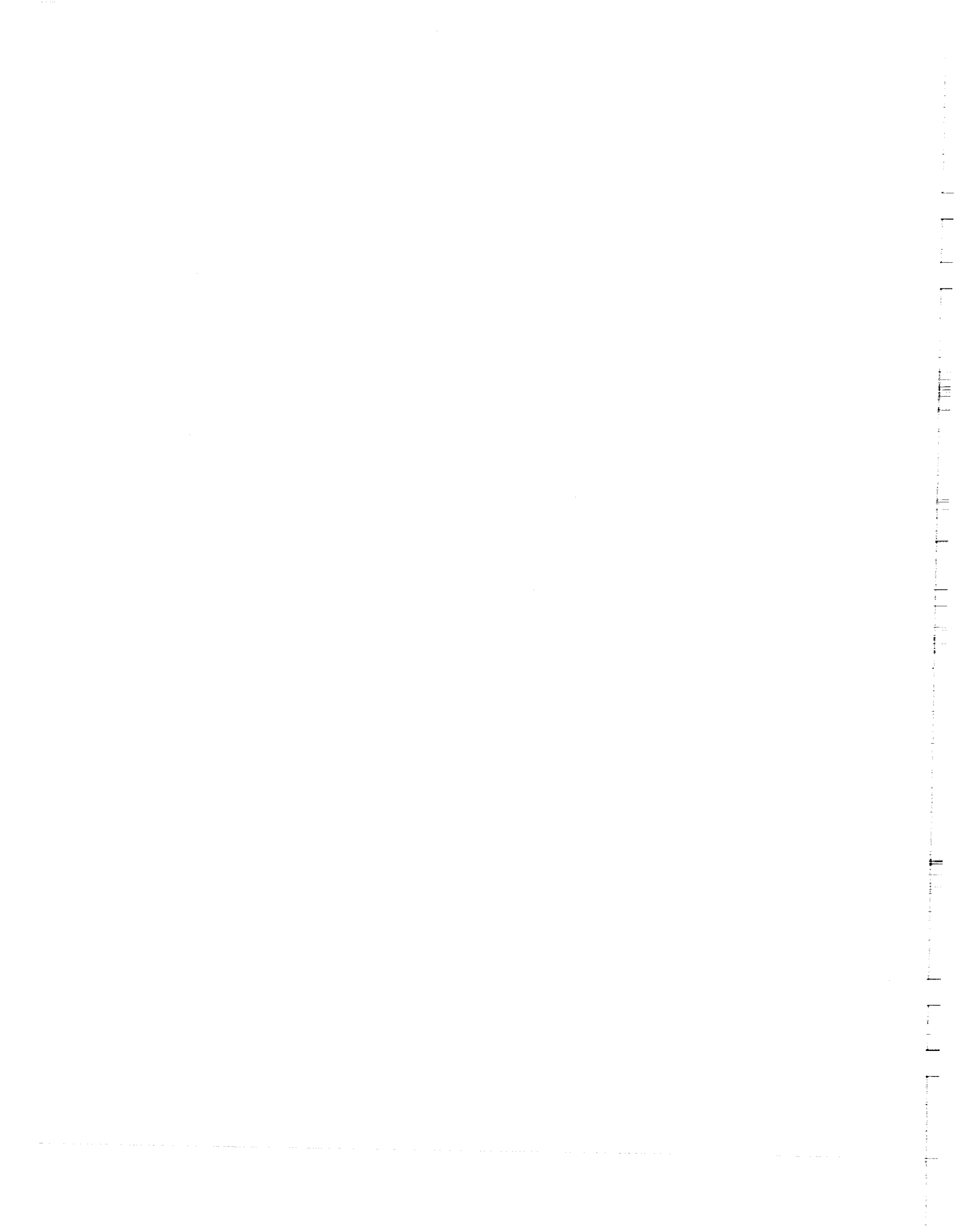

CHAPTER 4

SURFACE PREPARATION

The highest quality powder coating will provide excellent results only if the pretreatment (cleaning, phosphatizing, conversion coating) is done correctly and the overall pretreatment system is maintained up to its potential. Powder coating brings pretreatment back to the basics of cleaning, rinsing, phosphatizing, and seal rinsing.

To maximize the benefit derived from powder, the pretreatment system must provide a clean conversion coated product in a dry state to the powder booth.

Surface preparation encompasses more than conditioning or improving a substrate to accept the powder coating. Items that should also be considered include:

- Soils on the substrate;
- Water quality for bath makeup and rinsing;
- Consistent or varying substrates;
- Metals mix—ferrous, nonferrous, yellow metals;
- Metal types—cast, extruded plate, coil, sheet, or combinations;
- Size, weight, dimensions, and configurations of product; and
- System control, maintenance, and record keeping.

Considering all key elements involved in producing a high-quality powder-coated product,

one truly stands alone—*cleaning*. Cleaning is the single most important function in maximizing powder coating results. The degree of cleaning or surface modification is open to a wide interpretation and many differing qualities. For some applications, abrasive cleaning alone is suitable, especially if the final product requires short-to-medium duration adhesion properties.

Leading powder coating and pretreatment manufacturers tend to agree that a high-quality five-stage spray system of cleaning, iron phosphatizing, and final deionized rinsing is the most suitable and preferred method of pretreatment for the widest range of substrates and coating chemistries. Work closely with your pretreatment and powder coating vendor, and select those who work well together on your behalf.

CLEANING METHODS

Mechanical methods of cleaning can be generally applied to all types of surfaces since they involve abrasion of a surface by scrubbing, sanding, grinding, tumbling or vibrating with abrasive media, and wet (slurry) or dry abrasive blasting. Along with the cleansing action (removal of loose soils and tightly adhering contaminants such as mill scale on steel), these processes may be selectively performed in a manner that produces an etched or “toothed” surface to improve the adhesion of coating films to the substrate. Prominent among the methods used to achieve both purposes simultaneously is abrasive blasting. Methods and systems of surface preparation by dry blast cleaning include:

Chapter 4

- Open airblast with sand or various slag-type abrasives.
- Manual airblast in environmentally controlled enclosures (airblast rooms), with or without materials conveyor systems.
- Automated centrifugal wheel blast.
- Centrifugal wheel and airblast systems, in tandem or at separate locations in the path of product flow.

Airblast

The practice of blasting parts for cleaning or improving material surfaces goes back many years. It was called "sandblasting" because it was accomplished by introducing ordinary sand into a column of high velocity air supplied by an air compressor, and manually directing the stream of sand at the surface to be treated. However, because a wide variety of abrasives are commonly used, the process is more appropriately called "airblasting" or "nozzle blasting."

Portable nozzle blast systems have been developed in which an abrasive, after it has impinged the surface, is entrapped at the blast head, recovered by vacuum, and recirculated. The result is a virtually dust-free blasting operation in the field.

These developments have extended many benefits in varying degree, according to the nature of the blasting operation. Operating costs have been reduced through re-use of abrasives, automated processing, and/or improved working conditions for blast operators. Improved environmental conditions and reduced air pollution have resulted from the use of portable, recoverable abrasive blast systems and blast enclosures. The capacity for processing greater numbers and types of parts, including very large parts, in a shop operation has been increased.

Blasting with nozzles is a practical production process, used in several industry classifications. In many situations, it is the only means of achieving the preparation process. Modern airblast

enclosures, automated blast nozzle systems, and other innovations in the airblast systems have contributed in large measure to achieving environmentally acceptable airblast processes.

Airless (Centrifugal Wheel) Blast

Introduced in the 1930s was a device that hurled abrasive material by centrifugal force. Machine systems available for various applications differ only in the means by which the product is conveyed through the blast, the number and size blast wheels required, and the type of blast media used. All centrifugal blast systems, whether for shop installation or for portable use, have the same six basic components:

1. A blast enclosure is provided to contain the abrasive as it is thrown from the wheel and to prevent generated dust from escaping to surrounding areas.
2. As part of the system, there is a means of presenting the workpiece to the blast.
3. The heart of the system resides in the wheel or wheels, in whatever size and number required for a specific application.
4. A means of recapturing and recirculating the spent abrasive is normal in all industrial systems.
5. To remove contaminant particles and abrasive too small to be effective, an airwash separator is included, which then returns the cleaned and usable abrasive to a storage hopper.
6. Essential is a dust collector that withdraws dust from the abrasive and ventilates and removes dust from the blast enclosure.

For applications in which the type and shape of parts and the process requirements may be accommodated for centrifugal blasting, the economy benefit has been proven many times over. Production rates are greatly increased, and

production costs significantly reduced. Airless blast cleaning operations are far less labor-intensive and far more energy-efficient than airblasting. Uniformity of quality in the finished product is enhanced in automatic and environmentally clean operations.

Method Selection

Either method of abrasive blasting may be incorporated readily into continuous in-line conveyORIZED production cleaning and coating operations. Generally, the airless method is more productive and economical than airblast. In airblast systems, accelerating the abrasive particles (particularly the higher density ferrous abrasives) requires high volumes of clean, dry, compressed air, which in turn demands high energy input. Centrifugal blast systems require only about 10% of the energy (horsepower) needed by airblast systems to throw equal volumes of abrasives at the same velocities. Conversely, the shape (or configuration) of the workpieces may dictate the selection of airblast systems because of the ability to position individual nozzles to direct the blasts into nooks and crannies that may be shadowed from the blast pattern of the centrifugal wheel. Often, the two methods may be used in tandem.

Successful abrasive blast cleaning and/or finishing operations require judicious selection of the combination of blast system and abrasive media to achieve the desired finish on the material and configuration of the part to be processed.

Applications

Abrasive blasting involves high-velocity propulsion and direction of abrasive particles against surfaces of parts or products, for removal of contaminants and/or otherwise conditioning the surfaces for subsequent final finishing operations. Typical uses of abrasive blasting include:

- Removing contaminated surface layers;
- Removing oxides, corrosion products, and mill scale;

- Removing dry soils, mold, sand, and paint;
- Removing burrs, scratches, and surface irregularities;
- Providing an anchor pattern for better adhesion of paints or other coatings;
- Producing a hammered or matte surface finish; and
- Etching and carving for decorative finishes.

Types of materials that are abrasive blasted to prepare the surface for subsequent finishing operations and/or to produce the desired final surface finish include:

- Ferrous and nonferrous castings, forgings, rolled and formed shapes, and weldments;
- Thermoplastic and thermosetting plastic parts; molded rubber parts; and
- Diverse types of materials, including glass, wood, and leather.

Abrasives

Numerous types of materials can perform surface preparation by abrasive blasting. Selecting blast media depends on the type of material and product to be processed and on the nature of the surface finish to be produced. A wide range of abrasives is available.

Naturally occurring abrasives, generally referred to as "sands," include silica sands as well as heavy mineral sands (with little or no free silica) such as magnetite, staurolite, and olivine rutile. Others used for specialty-type operations include garnet, zircon, and novaculite. Generally speaking, the use of these materials is limited to nozzle-blast systems.

Mineral slags, derived from metal smelting and electric power generating slags (bottom-ash), are a rapidly growing source of abrasives for cleaning new, corroded, or painted steel surfaces. As with

Chapter 4

sand, the use of these highly aggressive products is generally limited to the airblast systems.

Byproduct abrasives are mainly agricultural in character. Byproducts such as walnut and pecan shells and peach pits are excellent for use in both air and airless blast systems for removing paint, fine scale, and other surface contaminants without altering the metal substrate. Corncob particles are effective for removing surface contaminants such as grease and dirt without destroying or altering a painted or bare metal surface. Media of these kinds are also frequently used in deflashing molded rubber and plastic parts.

Manufactured abrasives may be nonmetallic. Included in this category are glass beads for peening and cleaning small, delicate parts, and plastic media commonly used (like the agricultural by-products) for deflashing molded rubber and plastic parts. Materials such as aluminum oxide and silicon carbide are frequently used for specialty etching or for cleaning metals such as stainless steel, aluminum, and copper. Aluminum oxide is frequently used (primarily in airblast systems) for cleaning and etching steel.

The most commonly used manufactured abrasives are cut stainless steel wire and aluminum shot, principally for surface preparation and shot peening of nonferrous alloy parts.

Some manufactured abrasives are ferrous metal. Three general types are available for surface preparation—chilled cast iron shot and grit, malleable iron shot and grit, and cast steel shot and grit. Of these, the cast steel abrasives are, by far, the most frequently used. Since they are available in broad ranges of size and hardness, these abrasives have applications ranging from deflashing rubber parts with shot to etching hardened steels with hardened grit.

Precautions

Soils that adhere to the blasted surface or to the abrasive particles may be the source of defects in a subsequently applied coating, such as paint or enamel.

Parts on which oil or grease are present cannot be blast-cleaned properly. These substances resist removal and, in recirculating abrasive systems, may contaminate the abrasive itself. It is, therefore, essential that oil and grease deposits be removed by solvent-wiping or degreasing methods prior to blast cleaning.

Surfaces to be blast cleaned should also be dry, although traces of moisture can be tolerated when the heat generated by the blast is sufficient to vaporize moisture. Larger amounts of moisture cause the dust fines generated during the blasting to adhere to the part surface. Failure to remove such dust may cause defects in a coating system. Excessive moisture also causes dust to adhere to the abrasive particles and, in a recirculating abrasive system, will inhibit thorough air-wash cleaning of the abrasive and the removal of dust fines from the system.

Blast profile should be consistent. Situations where media is allowed to degrade, or where control is lacking, cause incomplete scale and corrosion removal. This produces a non-uniform substrate and a subsequent decrease in ultimate powder coating durability. Where there is a combination of non-uniform profile and low-mil build of powder, reduced corrosion protection is common. This is caused by the peaks of the profile extending above or through the powder coating.

Advantages

Abrasive blasting has numerous advantages, especially when combined with subsequent aqueous conversion coatings or phosphating. The prepared substrate is void of scale, corrosion, and soils; it is uniform, and offers mechanical adhesion properties along with under-film corrosion protection similar to that of chemical conversion coatings.

Mechanical blasting offers advantages over chemical removal when cleaning hot rolled steel substrates. Mechanical is faster, safer for workers and, when controlled, provides a more uniform profile that is less likely to re-oxidize. Abrasive

or glass bead mechanical conditioning of nonferrous castings of zinc and aluminum is in many cases the easiest way to deal with problematic castings for powder coating.

CHEMICAL SURFACE PREPARATION

The chemical surface preparation used in any particular application is closely related to the nature of the surface being cleaned and the nature of the contamination. Most surfaces powder coated after cleaning are either galvanized steel, steel, or aluminum. Since not all chemical-type preparations are applicable to all these materials, the preparation process selected depends on the substrate material. For each material, the type of cleaning will be discussed and its unique features for that substrate will be explained. Specific application processes are quite similar for each material.

CLEANING GALVANIZED STEEL

Alkaline Cleaners

Alkaline cleaners for galvanized steel usually have a blend of mild alkaline salts that do not damage the zinc surface. In some cases, a small-to-moderate amount of free caustic soda may be present in the cleaner to remove difficult soils or to provide a desired etch. These cleaners can be applied by power spray, immersion, electrocleaning, or hand wipe.

In the power spray method, the parts to be cleaned are suspended in a tunnel while the cleaning solution is pumped from a holding tank and sprayed, under pressure, onto the parts. The cleaning solution then is continuously recirculated. Spray pressure ranges from 4 to 40 psi.

In the immersion method, parts to be cleaned are simply immersed in a solution of the cleaner contained in a mild steel or stainless steel tank.

Electrocleaning is a specialized version of immersion cleaning in which a direct current is passed through the solution. The parts to be

cleaned are hung in the solution and are the anode, while other electrodes act as the cathode. Electrocleaning is more effective than plain immersion due to the scrubbing action of the gas bubbles produced at the surface of the part.

The hand-wiping method of application derives additional benefit from the physical act of removing the soil from the surface by means of a cloth or sponge, with the cleaner helping to solubilize the soils.

Alkaline cleaners are usually applied to galvanized zinc surfaces in two stages—the cleaning stage and a water rinse stage. The parts to be cleaned are usually conveyed from one stage to the other after suitable exposure to produce cleaning. Additional stages of cleaning and rinsing may be used if required. The chemicals in the baths for this type are usually maintained at a temperature between 80 and 200°F (27 and 93°C). Typically the temperature is 120 to 150°F (49 to 66°C) for spray and 150°F (66°C) for immersion. The time for which the parts are exposed to these chemicals is between 30 seconds and 5+ minutes. Generally, it is 1 to 2 minutes for spray and 2 to 5 minutes for immersion. To be effective, the concentration of such alkaline cleaning solutions should be between 1/4 and 16 oz/gal (2 to 120 g/L). Typically, in the spray the concentration is 1/2 to 1 oz/gal (4 to 8 g/L) and for immersion 6 to 12 oz/gal (45 to 90 g/L).

The most expensive of these types is the electrocleaner, due to the higher bath concentrations used and the cost of electricity for the electrocleaner. The least expensive is the spray cleaner, with hand-wiping somewhere in between. The alkaline type is, by far, the most effective and usually the least expensive to operate. In order of decreasing performance, the methods of application would generally be rated as: electrocleaning, spray cleaning, immersion cleaning, and hand-wiping.

Acid Cleaners

Acid cleaners are not normally used to clean galvanized steel. Of those acid cleaners that are

Chapter 4

used, the most common type would be mildly acidic salts, not too corrosive to the zinc surface. It should be noted, however, that there are specialty acid cleaners designed to remove white corrosion product from galvanized surfaces.

In the power spray method of application, the parts to be cleaned are suspended in a tunnel while the cleaning solution is pumped from a holding tank and sprayed under pressure onto the parts. The cleaning solution then is drained back into the holding tank and the cycle repeated. The pumping, spraying, and draining operations take place simultaneously and continuously.

When the immersion method of application is used, the parts to be cleaned are simply immersed in a solution of the cleaner contained in a mild steel or stainless steel tank.

Electrocleaning with acid cleaners is a specialized version of immersion cleaning in which a direct current is passed through the solution. The parts to be cleaned are usually the anode, while other electrodes act as the cathode. Electrocleaning usually produces a cleaner surface than plain immersion due to the scrubbing action of the oxygen bubbles coming off at the surface of the part. The oxygen is a result of the electrolysis of the water.

The hand-wiping method derives additional benefit from the mechanical aid of physically moving the soil from the surface by means of a cloth or sponge with the cleaner helping to solubilize the soils.

Acid cleaners are usually applied to galvanized zinc surfaces in two stages: the cleaning stage and a water rinse. Additional stages, cleaning and rinsing, may be used if required. The chemicals in the bath are maintained at a temperature of 80 to 200°F (27 to 93°C); typically 100 to 140°F (38 to 60°C) for spray and 140 to 180°F (60 to 82°C) for immersion. The parts are exposed to the chemicals for 30 seconds to 5+ minutes; typically 1 to 2 minutes for spray and 2 to 5 minutes for immersion. The solutions are kept at a concentration of 1/4 to 16 oz/gal (2 to 120 g/L); typically 1/2 to 1 oz/gal (4 to 8 g/L) for spray and 4 to 12 oz/gal (30 to 90 g/L) for immersion.

In order of decreasing performance, the methods of application would generally be rated as: electrocleaning, spray cleaning, immersion cleaning, and hand-wiping.

Neutral Cleaners

A neutral cleaner (as used for galvanized steel) may be composed of surfactants only, neutral salts plus surfactants, or surfactants with other organic additives. A neutral cleaner may be defined as any cleaner which, in solution, would register between 6 and 8 on the pH scale.

With the power spray method, parts to be cleaned are suspended in a tunnel while the cleaning solution is pumped out of a holding tank and sprayed, under pressure, onto the parts. The cleaning solution is continuously recirculated. Spray pressure ranges from 4 to 40 psi.

In the immersion method of application, the parts to be cleaned are simply immersed in a solution of the cleaner contained in a mild steel or stainless steel tank.

Once again, hand-wiping has an additional benefit from the mechanical aid of physically moving the soil from the surface by means of a cloth or sponge, with the cleaner helping to solubilize the soils.

Neutral cleaners are usually applied by using a minimum of two stages: the cleaning stage and a water rinse. Additional stages, a cleaning and rinsing, may be used if required. The solutions are held at a temperature of 80 to 200°F (26 to 93°C); typically 120 to 160°F (49 to 71°C) for spray and 150 to 180°F (66 to 82°C) for immersion. The parts are exposed for 30 seconds to 5+ minutes; typically 1 to 2 minutes for spray and 2 to 5 minutes for immersion. The solutions are held at a concentration of 1/4 to 16 oz/gal (2 to 120 g/L); typically 1 to 2 oz/gal (8 to 16 g/L) for spray and 8 to 14 oz/gal (60 to 105 g/L) for immersion.

Neutral cleaners are not effective as the primary cleaner. They are more likely to be used as a precleaner.

Conversion Coating of Galvanized Steel

Iron phosphates or cleaner-coater products produce little or non-detectable conversion coatings on zinc surfaces. Many multimetal finishing lines use modified iron phosphates which offer cleaning, and leave micro-chemical etch on zinc substrates to provide adhesion properties.

Many municipalities and states now have limits on zinc PPMs, forcing metal finishers to provide treatment of any solutions in which zinc substrates are processed.

The zinc phosphate conversion coating is, perhaps, the highest quality coating that can be produced on a galvanized surface. To produce a zinc phosphate coating on galvanized, special accelerating agents are required to activate the surface sufficiently to receive the zinc phosphate coating. These coatings are created by the action of bath chemicals on the surface materials. A crystalline zinc phosphate is actually "grown" on the clean substrate surface. In a typical seven-stage zinc phosphating unit, the various stages are:

1. Alkaline cleaner.
2. Alkaline cleaner.
3. Hot water rinse.
4. Zinc phosphate processing solution.
5. Cold water rinse.
6. Post treatment (either chromium or nonchromium type).
7. Deionized water rinse.

A six-stage unit would eliminate stage 1, and a five-stage unit would eliminate stages 1 and 7.

In the power spray method of application, the parts to be coated are suspended in a tunnel while

the solution is pumped from a holding tank and sprayed under pressure onto the parts. The coating solution is continuously recirculated.

In the immersion method of application, the parts to be coated after being cleaned are simply immersed in a solution of the phosphating solution contained in a stainless steel tank.

The hand-wiping method of application has limited use in conversion coating technology.

Phosphate coatings are usually applied by using five, six, or seven stages. The phosphate solution is held within a temperature range of 100 to 160°F (38 to 71°C) for spray; 120 to 200°F (49 to 93°C) for immersion; or room temperature for hand-wiping.

The applied zinc phosphate coating weight should be 150 to 300 mg./sq. ft.

A processing time of 30 to 60 seconds by spray and 1 to 5 minutes by immersion is usual. Phosphating solutions have a concentration of 4 to 6% by volume and are applied at spray pressure of 5 to 10 psi.

The zinc phosphate coating is probably one of the best paint base coatings on galvanized steel. A chromium phosphate processing solution does not produce a suitable paint base coating on galvanized steel.

CLEANING ALUMINUM

Alkaline Cleaners

Alkaline cleaners for aluminum differ from those used for steel; they usually have a blend of mild alkaline salts to avoid attacking the aluminum surface. In some cases, a small to moderate amount of free caustic soda may be present in the cleaner to remove difficult soils, or to provide a desired etch.

In the power spray method of application, the parts to be cleaned are suspended in a tunnel while the cleaning solution is pumped from a

Chapter 4

holding tank and sprayed, under pressure, onto the parts. The cleaning solution is continuously recirculated. Spray pressure ranges from 4 to 40 psi.

In the immersion method of application, the parts to be cleaned are simply immersed in a solution of the cleaner contained in a mild steel or stainless steel tank.

Electrocleaning is a specialized version of immersion cleaning in which a direct current is passed through the solution. The parts to be cleaned are usually the anode, while other electrodes hanging in the tank act as the cathode. Electrocleaning is more effective in cleaning than plain immersion due to the scrubbing action of the oxygen bubbles coming off at the surface of the part. Oxygen results from the electrolysis of the water.

The hand-wiping method of application derives additional benefit from the physical act of removing the soil from the surface by means of a cloth or sponge, with the cleaner helping to solubilize the soils.

Alkaline cleaners are usually applied to aluminum by using a minimum of two stages: the cleaning stage and a water rinse. Additional stages, a cleaning and rinsing, may be used if required. The chemical baths are held at a temperature of from 80 to 200°F (27 to 93°C), typically 100 to 140°F (38 to 60°C) for spray and 140 to 180°F (60 to 82°C) for immersion. Parts are exposed to the chemicals for 30 seconds to 5+ minutes; typically 1 to 2 minutes for spray, and 2 to 5 minutes for immersion. A bath concentration of 1/4 to 16 oz/gal (2 to 120 g/L) is used; typically 1/2 to 1 oz/gal (4 to 8 g/L) for spray and 6 to 12 oz/gal (45 to 90 g/L) for immersion.

Comparing the cost of using the various types of chemical cleaners, the most expensive would be the immersion electrocleaner due to the higher concentrations used and the cost of electricity for the electrocleaner.

The least expensive would be the spray cleaner, with hand-wiping being somewhere

between. The alkaline type is, by far, the most effective of the cleaner types and usually the least expensive to operate.

In order of decreasing performance, the methods of application would generally be rated as: electrocleaning, spray cleaning, immersion cleaning, and hand-wiping.

Acid Cleaners

Acid cleaners for aluminum are composed of mildly acidic salts or a phosphoric acid base. In either case, any oxide film on the aluminum will be removed by the acidic medium. The acid cleaners are usually not as effective in cleaning common soils as the alkaline cleaners.

In the power spray method of application, the parts to be cleaned are suspended in a tunnel while the cleaning solution is pumped from a holding tank and sprayed, under pressure, onto the parts. The cleaning solution is continuously recirculated.

When the immersion method of application is used, the parts to be cleaned are simply immersed in a solution of the cleaner contained in a mild steel or stainless steel tank.

Hand-wiping derives additional benefit from the physical aid of removing the soil from the surface by means of a cloth or sponge, with the cleaner helping to solubilize the soils.

Acid cleaners are usually applied to aluminum using a minimum of two stages, the cleaning stage and a water rinse. Additional stages, a cleaning and rinsing, may be used if required. The acid solutions are held at a temperature of 80 to 200°F (27 to 93°C); typically 100 to 140°F (38 to 60°C) for spray and 140 to 180°F (60 to 82°C) for immersion. Parts are exposed for 30 seconds to 5+ minutes; typically 1 to 2 minutes for spray and 2 to 5 minutes for immersion. Solutions are held at a concentration of 1/4 to 16 oz/gal (2 to 120 g/L) for spray and 6 to 12 oz/gal (45 to 90 g/L) for immersion.

Comparing the cost of using various cleaners, most expensive would be immersion due to the higher concentrations used. The least expensive would be the spray cleaners, with hand-wiping somewhere between.

In order of decreasing performance, the methods of application would generally be rated as: spray cleaning, immersion cleaning, hand-wiping.

Neutral Cleaners

A neutral cleaner for aluminum may be composed of surfactants only, neutral salts plus surfactants, or surfactants with other organic additives. A solution of a neutral cleaner will usually register between 6 and 8 on a pH scale.

In the power spray application, parts to be cleaned are suspended in a tunnel while the cleaning solution is pumped from a holding tank and sprayed under pressure onto the parts. The cleaning solution is continuously recirculated. Spray pressure ranges from 4 to 40 psi.

The hand-wiping method of application derives additional benefit from the physical act of removing the soil from the surface by means of a cloth or sponge with the cleaner helping to solubilize the soils.

Neutral cleaners usually are applied to aluminum using a minimum of two stages: the cleaning stage and a water rinse. Additional stages, a cleaning and rinsing, may be used if required. Neutral cleaners are held in the temperature range of 80 to 200°F (27 to 93°C); typically 120 to 160°F (49 to 71°C) for spray and 150 to 180°F (66 to 82°C) for immersion. Parts are exposed to the cleaners for 30 seconds to 5+ minutes; typically 1 to 2 minutes for spray and 2 to 5 minutes for immersion. The chemical concentration is between 1/4 to 16 oz/gal (2 to 120 g/L) typically 1 to 2 oz/gal (8 to 15 g/L) for spray and 8 to 14 oz/gal (60 to 105 g/L) for immersion.

Neutral cleaners are not effective as the primary cleaner. They are more likely used as a pre-cleaner.

Conversion Coating of Aluminum

A standard iron phosphate processing solution can only produce a coating on aluminum if certain accelerators are used. The coating produced, however, is not an iron phosphate, but an aluminum phosphate. The accelerator normally used is a proprietary product. In phosphating an aluminum surface, a chemical action takes place on the surface, producing a crystalline coating on the surface. Iron phosphating of aluminum is not an ideal operation but is usually expedient where mixed product—iron and aluminum—is being coated on a single line.

In the power spray method of application, parts to be coated are suspended in a tunnel while the coating solution is pumped from a holding tank and sprayed, under pressure, onto the parts. The coating solution is continuously recirculated. One specialized spray application uses a steam generator, where the chemical is siphoned into the steam at the nozzle. Spray pressure ranges from 4 to 40 psi.

In the immersion method of application, the parts to be coated are simply immersed in a solution of the coating solution contained in a mild steel or, preferably, a stainless steel tank.

The hand-wiping method of application has limited use in conversion coating technology.

A minimum of three application stages should be used for adequate quality; five for best quality. The solutions normally are held at a temperature between 98 and 120°F (32 and 49°C) for spray and 130 to 160°F (54 to 71°C) for immersion. Coating weights of 5 to 40 mg/square foot are normal. Parts are exposed to the chemicals for 1 to 2 minutes by spray and 3 to 5 minutes by immersion. Concentrations of 10 to 15 lbs/100 gal by spray and 20 to 30 lbs/1000 gal by immersion are applied at a spray pressure of 5 to 10 psi.

The aluminum phosphate coating produced from an iron phosphating solution is a relatively good paint base. The process is easy to operate and maintain, and can be applied in as few as three stages. The process, however, cannot be

Chapter 4

used exclusively for aluminum as this will shorten the effective life of the bath. To maintain the proper balance of chemicals in the bath, some steel must also be processed. The balance of chemicals in the bath also can be maintained through the use of special proprietary additives.

Zinc Phosphate

A zinc phosphate processing solution will produce a very good quality coating on aluminum. It is one of the best paint bases produced on an aluminum substrate.

In the power spray method, the parts to be coated are suspended in a tunnel, while the coating solution is pumped from a holding tank and sprayed under pressure onto the parts. The coating solution is continuously recirculated. A specialized spray application uses a steam generator where the chemical is siphoned into the steam at the nozzle. When immersion is the method of application, the parts to be coated are simply immersed in a solution of the coating solution contained in a mild steel or, preferably, stainless steel tank.

The hand-wiping method has limited use in conversion coating technology.

To adequately create a zinc phosphate coating on aluminum, five operation stages are usually required. The temperature of the solution is between 108 and 160°F (38 and 71°C) for spray and 120 to 200°F (49 to 93°C) for immersion. Coating weights of 50 to 200 mg/square feet are usual. A time of 1 to 3 minutes by spray and 2 to 5 minutes by immersion is needed. Solutions having a concentration of 4 to 6% by volume are applied at spray pressure of 5 to 10 psi.

A zinc phosphate processing solution can be used exclusively for producing a conversion coating on aluminum. It is a very good paint base, but produces a lot of insoluble sludge. This sludge can deposit on plate coils, causing a decrease in heat transfer efficiency. It can also plug up the nozzles and piping in a spray application. It is, therefore, necessary to clean out the zinc phos-

phate coating stage in the processing line at least once a year.

Chromium Phosphate

The chromium phosphate conversion coating is probably the best conversion coating paint base that can be applied to an aluminum surface. It is, however, limited to treating aluminum.

When power spraying is the method of application, the parts to be coated are suspended in a tunnel, while the coating solution is pumped from a holding tank and sprayed, under pressure, onto the parts. The coating solution is continuously recirculated.

In the immersion method of application, the parts to be coated are simply immersed in a solution of the coating chemical contained in a stainless steel tank.

The hand-wiping method has limited use in corrosion coating technology.

When aluminum parts are chromium phosphated, usually five stages are used. The solutions are held at a suitable temperature between 70 and 130°F (21 and 54°C). A coating weight of 20 to 100 mg/square foot is normal. Parts are exposed to solutions with concentrations of 2 to 5% by volume for a time of 5 to 60 seconds. Solutions are sprayed at a pressure of 5 to 10 psi.

The chromium phosphate conversion coating is superior to zinc phosphate as paint base on aluminum. It exhibits better salt spray resistance and offers improved adhesion. It is less expensive to maintain and is easier to control. However, it is limited to use on aluminum only and requires a stainless steel tank.

CLEANING STEEL

Cold-Rolled Steel

Commonly referred to as "mild steel" or CRS, cold-rolled steel is available in coil, sheet, and a

variety of forms. The surface is free from heat scale and, if properly protected by a corrosion preventive or adequate packaging, is free of rust. HRS, hot-rolled steel, is also available in coil, sheet, and a variety of forms. The surface is typically covered with a blue/black heat scale, which will flake off upon bending or flexing the metal. HRPO, hot-rolled, pickled, and oiled refers to steel that has been pickled to remove the blue heat scale and oiled to prevent rusting.

During the manufacturing and/or assembly of a particular piece of ware, the steel surface can become soiled with drawing compounds, a variety of lubricants or lubricating oils, shop dirt, weld splatter, marking inks, chalk, etc. These must be removed for a good adhering finish. Knowing the chemical nature of these soils will help in their removal.

Alkaline Cleaners

Because steel surfaces are resistant to attack by aqueous alkaline solution, an extremely wide variety of alkaline cleaners can be formulated for each specific application. In general, combinations of phosphates, silicates, and carbonates, with varying amounts of caustic, may be encountered. In addition, sequestering agents or chelating agents, solvent, solvent couplers, dispersants, and one or more surfactants, nonionic or anionic, are used.

Liquid, moderately alkaline cleaner solutions may be applied to the surface to be cleaned, using a hand-held rag, brush, mop, etc. The "wetted" soil is allowed to soak for a period of time and is then spray rinsed with water and/or dried by rag-wiping or blowing the surface dry with compressed air. The cleaner solution can be applied and reapplied until a sufficiently clean surface is obtained, which is then rinsed. Applied with a hand-held rag or brush, the solution is normally unheated or warmed only slightly. Application should be made only to an area that can be handled by one person, to provide cleaning and rinsing with a minimum of streaking, drying, etc. When the solutions are to be wiped or brushed onto the surface, concentrations of 5 to 20% are used.

Solutions of alkaline cleaners can be applied to a soiled surface by mixing the aqueous solution with steam and spraying the steam/cleaner mixture on the soiled surface through hand-held steam guns. When the elevated temperature is not required, diluted aqueous alkaline solutions can be pressure-sprayed on the soiled surface. Rinsing is usually accomplished without the addition of cleaner solution. The surface is either blown dry with compressed air or allowed to air dry. When sprayed, the cleaner solution is continuously applied to the soiled surface for a sufficient time to permit acceptable cleaning and is then rinsed in the same manner. The temperature of the cleaner solution is nominally controlled by the quantity and temperature of the steam mixed with the cleaner solution. Application using a hand-held gun by one person should be made only to an area where adequate cleaning and rinsing, with a minimum of streaking and flash drying, is obtained. Nominal concentration of the solutions requires 1% to 1 oz/gal at the nozzle.

When alkaline cleaners are used with the immersion process, the surface to be cleaned is immersed or dipped into a cleaner solution contained in a tank. Added features of heat, agitation (mechanically or by means of ultrasonic cavitation), or the application of electric current to permit electrocleaning may be incorporated. The ware is immersed in the cleaner solution until acceptable cleaning is obtained. Simple immersion cleaning followed by ultrasonic cleaning or electrocleaning is only used where cleaning requirements are very severe. Solution temperatures are usually between 140°F (60°C) and a gently rolling boil. Typical immersion times are on the order of 2 to 5 minutes. Extended times, up to one hour, may be used where heavy or difficult-to-remove soils are encountered. The concentrations of the solutions for light duty are 4 to 8 oz/gal (30 to 60 g/L), and for heavy duty 6 to 16 oz/gal (45 to 120 g/L).

Where a power spray washer is used, the ware to be cleaned or treated is suspended in a housing with appropriate pumps and piping, so that a heated solution is pressure-sprayed on the soiled

Chapter 4

surface. The solution flows on to the ware, runs off, and is diverted into a holding tank, from which it is continuously recirculated through a pump back onto the ware. Spray pressure must be sufficient to provide coverage of the ware with solution, and not excessive enough to cause wild movement of the hanging parts. Nominally, spray pressures are in the 20 to 40 psi range, more typically 15 to 20 psi.

A cleaner stage followed by a rinse stage is used for most of the work processed today. Where heavily soiled surfaces are encountered or a higher degree of cleanliness is required, additional stages are used. Depending upon the demands of the operation, cleaning is done in:

- 2 stages; clean/rinse;
- 3 stages; clean/clean/rinse; or
- 4 stages; clean/rinse/clean/rinse; or clean/clean/rinse/rinse.

Typical hot-process spray cleaners operate in the 140 to 160°F (60 to 71°C) range. Low-temperature cleaners nominally operate in the 90 to 120°F (32 to 49°C) range. When parts are carried by a monorail conveyor, cleaner stages of 45 to 60 seconds, and rinse stages of 30 to 45 seconds are typical. Solution concentrations used where the chemicals are powders are 1/2 to 2 oz/gal (4 to 15 g/L), and where they are liquid 1 to 3%.

Acid Cleaners

Mineral acids, i.e., sulfuric or hydrochloric acid, are commonly used to remove rust, heat scale, and corrosion products from steel. Organic acids and phosphoric acid, together with solvents, coupling solvent, and surfactants are used to both clean (remove soils) and remove red rust and other corrosion products.

Liquid acid rust removers containing detergents can be applied by hand, provided impervious protective gloves and other suitable protective equipment is used. There are also available in the

market viscous, brush-on rust and soil removers. Typically, acid rust removers are not used through a steam gun. A great amount of derusting of steel parts is accomplished by pickling, in hydrochloric or sulfuric acid, ware which has previously been alkaline cleaned. Strong acid cleaners are typically not used in spray equipment, except in highly specialized operations, such as pickling in primary steel mills. Moderate or mild acid cleaners are used in spray applications in limited cases or where direct-fired gas heating is encountered.

Iron Phosphate

A number of different proprietary compositions can be used to produce an iron phosphate conversion coating on steel surfaces. These compositions are all mildly acid and are principally monosodium phosphate in either liquid or powdered form, to which are added various accelerating agents and other ingredients. When the functions of both cleaning and coating are desired in one stage, a detergent surfactant package can be incorporated with the iron phosphate composition in one package, or can be added separately at tankside, when required.

Moderate or strong acid proprietary compositions, capable of removing rust and containing surfactants and solvent to remove oils and soils, can be wiped or brushed on steel to produce a light iron phosphate coating. Aqueous solutions are applied using a rag or mop. The solution can be reapplied where and when necessary, until the surface is clean and free of rust, and the light iron phosphate has developed. The time required is determined by what is needed for the manual application of the solution to a suitable area, to remove the soils and produce the coating. The solution, applied by hand-held rag or brush, is normally unheated. Liquid acid products are used at 5 to 10% for light cleaning and 10 to 25% for moderate cleaning, rust removal, and the deposition of the iron phosphate coating.

Steam gun phosphatizing is best suited for extremely soiled substrates where the steam and chemical melt and displace tenacious wax-laden

solids or preservatives. Although steam-gun cleaning and phosphatizing works well, the process is typically manual and the effective cleaning area is only as wide as each pass of the width of the steam gun.

Hot-water high-pressure cleaning and phosphatizing hand-held systems are gaining popularity with custom coaters and manufacturers of large substrates or products. This application equipment generally operates at a minimum of 800 to 1600 psi, and at from 3 to 5 gpm of solution. Temperature ranges from a low of 140 to 200°F (60 to 93°C) at the nozzle tip, with chemical concentrations of from 1 to 3% by volume. Iron phosphate coating weights can reach 35 to 45 mgft², meeting TT-C-490C Type II requirements. When considering the use of high pressure, hot water, hand-held systems it is important to have systems built of stainless steel components as the phosphatizing solutions are acidic. Recent advances in this area also incorporate wet sandblasting attachments, which are effective in thoroughly cleaning weldments.

Iron phosphate conversion coatings can be applied by immersion application methods. Where light soils are encountered, the cleaning and coating can be accomplished in one stage, preferably with the assistance of some form of agitation. In general, immersion iron phosphate coatings will tend to look streaky and be of a light gray-blue color. Where soils are light, parts can be cleaned and coated in one stage, followed by water rinsing. Moderate to heavy soils require cleaning and coating in separate stages, each followed by a water rinse. Parts can be cleaned and coated in 2- to 5-minute time cycles if some form of agitation is used. Cleaner/coater processes can be operated in the temperature range of 90°F (32°C) up to 160 to 170°F (71 to 77°C). The operating temperature is normally controlled to meet the cleaning requirements of the soils encountered, and is influenced by the amount and type of agitation available. Typical concentrations used in such processes are for powder materials 2 to 4 oz/gal (15 to 30 g/L) and for liquids 2 to 5%.

Power spray washers are the most widely used method of applying an iron phosphate coating.

Depending upon the soil conditions of the ware and the quality level requirements, spray systems may consist of as few as two stages (cleaner/coater in one, water rinse in two), and as many as nine stages. Such washers are referred to as:

- Two-stage: clean/coat, rinse;
- Three-stage: clean/coat, rinse, post rinse;
- Four-stage: clean/coat, rinse, post rinse, D.I. flush;
- Five-stage: clean, rinse, treat, rinse, post rinse;
- Six-stage: clean, rinse, treat, rinse, post rinse, D.I. flush;
- Seven-stage: clean, clean, rinse, treat, rinse, post rinse, D.I.;
- Eight-stage: clean, rinse, clean, rinse, treat, rinse, post rinse, D.I.; and
- Nine-stage: clean, rinse, clean, rinse, treat, rinse, post rinse, recirculated D.I., fresh D.I.

The user, working with the chemical supplier, must decide how many stages will be needed, depending upon a great many factors, including the nature and amount of soil, the rinsing and/or draining geometry of the ware, and the quality levels required.

When a typical monorail conveyor system is used, the cleaner stages will require 45 to 60 seconds; treatments require 45 to 60 seconds; and rinse/post rinse/D.I. 15 to 30 seconds. Iron phosphate treatments can be accelerated to produce good quality coatings at various temperature ranges. Low temperatures will be 98 to 120°F (32 to 49°C) and hot processes will be 140 to 160°F (60 to 71.1°C). As the line is placed in operation, there is some thermal carryover, and rinse temperatures can approach to within 20 to

Chapter 4

40°F (11-22°C) of the temperature of the preceding stages. Typical iron phosphate cleaner/coaters are operated at 1 to 3 oz/gal (8 to 23 g/L) nominal concentration, depending upon temperature available, cleaning time, and soil condition. Typical iron phosphate treatments are operated at 3 to 5%, or at a typical 10 ml titration.

Zinc Phosphate

A great number of different proprietary compositions can be used to produce a zinc phosphate conversion coating on steel surfaces. These products are acid solutions containing zinc; dihydrogen phosphate in aqueous solution; one or more accelerating agents, typically zinc nitrate, with or without tankside additions of nitrite; and one or more modifying agents, grain-refining agents, coating weight control agents, etc.

Proprietary zinc phosphate coating compositions have been formulated which can be brushed on clean steel surfaces to produce a zinc phosphate coating. The surface must be precleaned prior to the application of the conversion coating, by any of the usual methods. The brush-on treatment is applied, the coating is allowed to develop, and the ware is then rinsed with fresh tap water and dried. The brush-on treatment will produce an acceptable coating in 2 to 5 minutes. Compositions are typically applied unheated, to a surface at room temperature. Since these are mostly proprietary formulations, the manufacturer's instructions must be followed to determine concentration. It is technically possible to produce a zinc phosphate coating on steel by applying the coating product through a steam gun. Due to the poor overall quality produced and the short life of the operating equipment, as well as

sludging and scaling, this method of application is not used.

Proprietary zinc phosphate coating compositions are available for immersion application; these will deposit a paint-base-quality coating of 150 to 300 mg./sq. ft. Typical immersion systems are composed of five stages: clean, rinse, zinc phosphate treatment, rinse, post rinse. Immersion zinc phosphate coatings can be developed in 2 to 5 minutes. Temperature requirements of 90 to 160°F (32 to 71°C) are needed, depending upon the particular process. Typical concentration is 3 to 6%.

As with iron phosphate processes, power spray washer application accounts for the largest proportion of paint-base zinc phosphate treatment processing. Depending upon a great many factors, including the nature and amount of soil, the rinsing and draining geometry of the ware, and the quality levels required, as few as five stages and as many as nine stages may be needed. Using a typical monorail conveyor system, the times utilized will be:

- Cleaner Stage: 45-60 seconds
- Treatment Stage: 45-60 seconds
- Post Rinse/Rinse/D.I.: 15-30 seconds

Zinc phosphate treatments can be accelerated to operate and produce good quality paint-base coatings at temperatures as low as 80 to 90°F (27 to 32°C). Typical zinc phosphate treatments are operated at 3 to 6% concentrations, or at a typical titration as low as 10 ml and as high as 25 ml, depending upon the quality requirement and particular proprietary treatment.

CHAPTER 5

METHODS OF APPLYING POWDER COATINGS

There are many methods available for applying powder coating materials, with selection based on such factors as:

- Product characteristics, including size of the part being coated, type of coating to be applied, desired or specified ultimate film thickness, reason for applying the coating, etc.;
- Production quantities;
- Number of colors used;
- Means of conveying the part through the coating process, line speed, and racking configuration;
- Means of applying the powder—automatically, manually, or a combination;
- Available plant space; and
- Capabilities of available powder coating equipment in meeting immediate and future needs.

Available methods range from simple fluidized beds to more sophisticated electrostatic spray processes. Each has particular advantages for specific coating applications. Generally, the most widely used and accepted powder application methods fall into the following categories:

1. Fluidized powder bed process.
2. Electrostatic fluidized bed process.
3. Electrostatic powder spraying.

4. Other electrostatic application methods, including discs and powder coating tunnels.

FLUIDIZED POWDER BED PROCESS

This method of applying powder coatings was introduced in the United States in the late '50s, and was the first powder coating process used in a production mode. In this process, a preheated part is immersed into a fluidized powder bed. The action of heat, and the powder coming into contact with the part, result in the powder being melted and adhering to the heated part. Material coating thickness on the part is determined by the part's temperature and the length of time the part is in the fluidized powder bed. Attaining the proper cure of the deposited powder may require post-heating the part, if the residual heat is not sufficient to cure and flow the powder that adhered during the immersion process. (Figure 5-1.)

Construction

The fluidized bed is constructed as a two-compartment container, or tank, with the top open so that parts to be coated can be dipped into the powder fluidized within the bed. The upper compartment is used for storage and fluidization of powder. A lower compartment serves as an air plenum where compressed air is regulated and dispersed through a porous membrane separating the two compartments, as illustrated in Figure 5-2.

The size of the fluidized bed depends on the size of the part to be coated. In the fluidized bed,

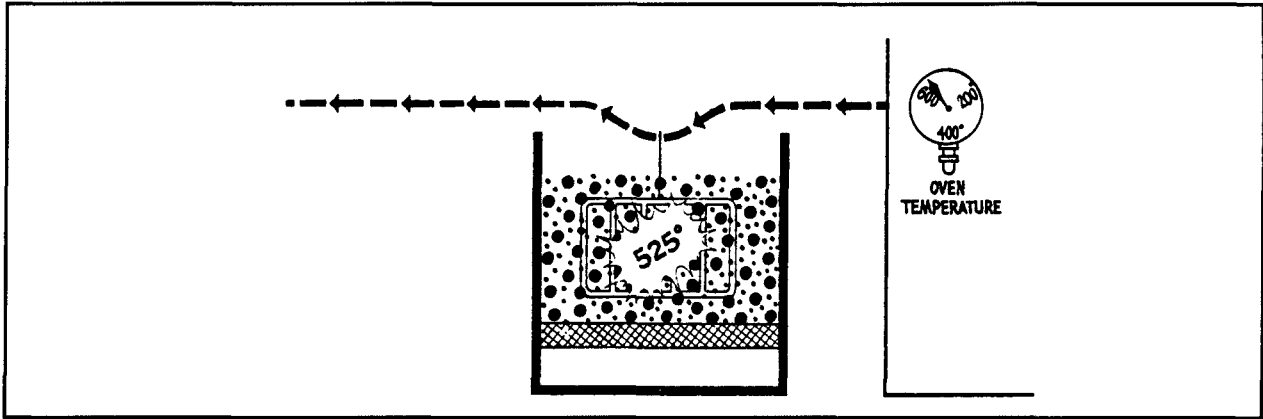

Figure 5-1. Note that the part temperature is the only thing that is important. The temperature in the oven serves only to heat the part.

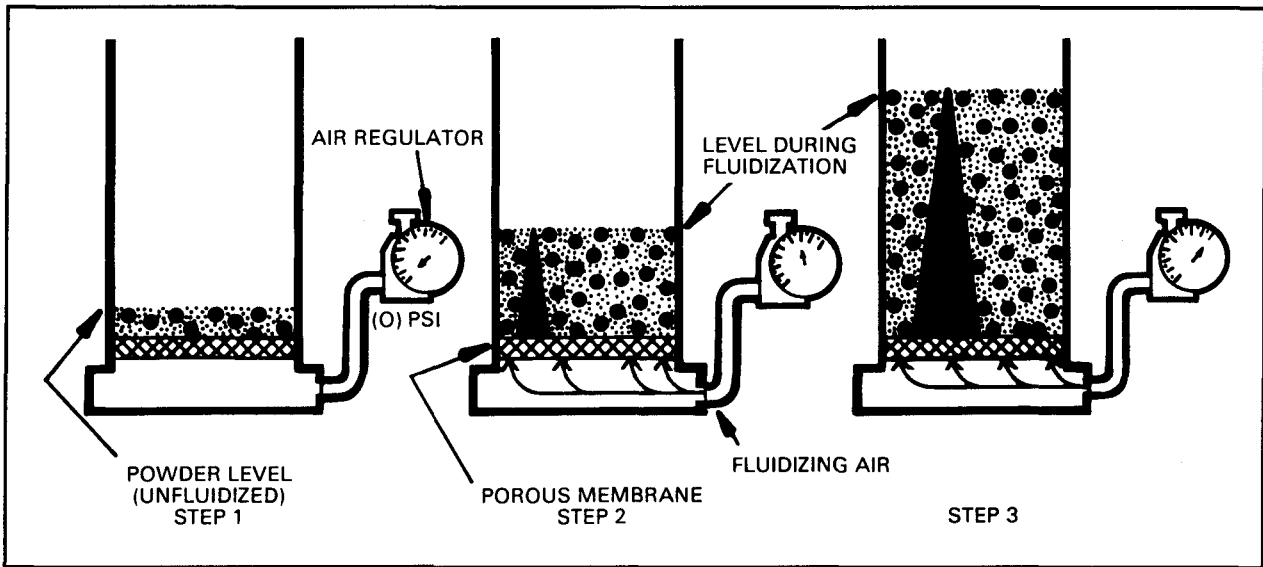

Figure 5-2. Fluidized bed.

the size of the tank and the volume of material, must allow the part to be immersed below the upper level of the fluidized powder. Proper fluidization is governed by even distribution of air through the porous membrane, or plate, creating a lifting effect and agitating the powder material, as is seen in the final step. Mechanical vibration of the container is sometimes used to enhance fluidization and reduce the possibility of air channeling and powder clumps. An important aspect of proper fluidization involves the quality of the compressed, or turbine blown, air introduced to the fluidized bed. Clean, dry air is an absolute must. Oil, water, or pipe scale contami-

nants within the air supply would result in blocking, and possibly rupturing, the porous membrane, as illustrated in Figure 5-3. This results in uneven fluidizing distribution, which will ultimately affect the finish of parts being coated. Contamination of the powder material is also a distinct possibility in cases where clean, dry air is not used.

The fluidized bed should be constructed with smooth walls that are virtually free of seams, flanges, or other protrusions coming into contact with the powder material. The porous membrane, or plate, can be constructed of any available

Methods of Applying Powder Coatings

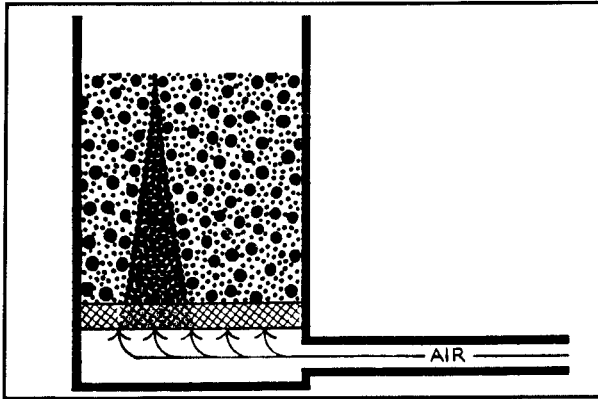

Figure 5-3. Blocked diffusion.

porous material. Size and thickness of the membrane should be sufficient to support the volume of powder material and provide complete fluidization to the interior of the porous bed. Electrical conductivity of the material used in bed fabrication is also important to help eliminate static charge. The container should be adequately grounded, to “bleed” off any static charge created by the frictional movement between the powder material and the container. Venting the porous bed into a duct is sometimes necessary for exhausting any powder particles that might escape the container. This venting is usually designed to ensure a clean, safe working environment.

Fluidization

Every powder coating material resin possesses its own peculiar fluidization characteristics. The amount of air required per cubic foot, density of the bed, physical conditions at the top and bottom strata, all vary with the particular formula. In all cases, however, it is essential that the bed be completely aerated from top to bottom.

A layer of “dead”—dense or compacted—powder immediately above the porous membrane may lead to progressive stratification that ultimately affects the coating results achieved at the dipping sector. This concept is illustrated in Figure 5-4.

For this reason, and others, it is desirable to make powder additions to the bed in frequent, low-quantity increments to replace powder

consumed on parts. A constant feed, conforming to production usage, is ideal, though not essential.

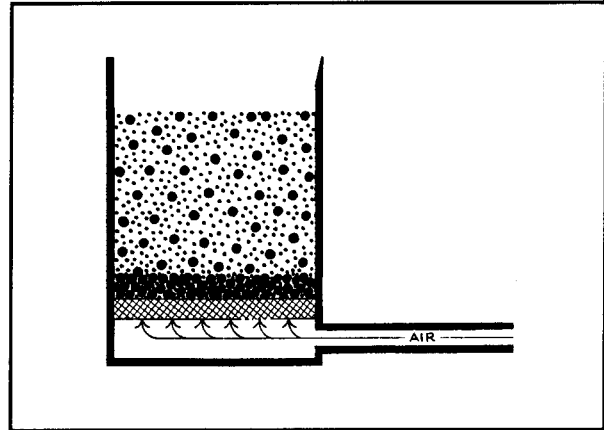

Figure 5-4. Fluidization. The “dead” dense powder at the bottom leads to stratification.

Bed Density

Density of a porous bed results from the nature of the powder itself and the operating conditions. In many circumstances, it may be varied arbitrarily to produce desired results. However, in deep beds it can become a critical factor.

The density of a particular powder may be measured, of course, by its weight per volume. That measure is, however, not sufficient to determine how it will fluidize. The best way to evaluate density in an operating bed is to measure percentage of expansion from static to porous condition. Correlating these data with previously determined standards indicates whether a particular powder will fluidize throughout a reservoir without requiring too much air or without exhibiting sluggishness in the tank, as shown in Figure 5-5.

This may be done simply by calibrating a small fluidizer to measure the percentage of expansion attained by a given amount of powder at the point of optimum fluidization.

Since all fluidizable powdered resins, thermo-setting or thermoplastic, exhibit a particle size distribution resembling a bell-shaped curve, it is significant that the bed’s composition changes

Chapter 5

during operation. There is a selectivity in deposition; the fines are removed from the bed at a higher rate than are the coarse particles.

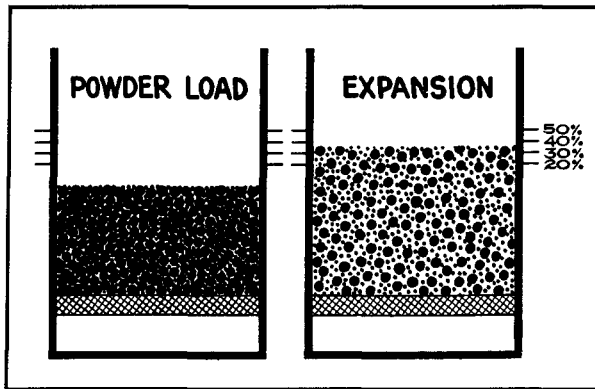

Figure 5-5. Powder load and expansion.

ELECTROSTATIC FLUIDIZED BED PROCESS

Although the phrase “electrostatic fluidized bed” is used in describing this process, the “fluidized bed” portion of the system is of lesser importance in the actual powder deposition than it is in a dipping process. This concept does not use a spray device or nozzle to apply the powder material to the parts.

In this process, the combination of the fluidized bed and electrostatic charging medium creates a cloud of charged powder particles above the powder bed. As in any fluidized bed, the powder material is fluidized by introducing compressed air through a porous membrane into the powder bed. Depth of powder material in the bed is usually 1/2" to 1".

An electrostatic charging medium charges the air used to fluidize, when high voltage DC potential is applied. Ionizing this air electrostatically charges the powder particles as the fluidizing air moves upward through the powder bed. The charged powder particles, having similar high electrical charges, thus repel each other and move upward. Aided by the fluidizing air, a cloud of charged powder forms above the upper surface of this powder bed. Grounded parts can be conveyed through or immersed into this cloud.

Basically, only the electrostatic field produced in this process is used to apply the powder material. In contrast to electrostatic spray methods, little air is used to control the volume and velocity of the powder material. Figure 5-6 illustrates this point.

Applications

The electrostatic fluidized bed is ideally suited to substrates that have a relatively small vertical dimension, such as flat sheets, expanded metal, wire mesh, screen, wire, cable, tubing, and small parts on a conveyerized line. The electrostatic fluidized bed offers the advantage of being able to coat some objects, such as flat sheets, on one side only; the conventional fluidized bed requires dipping of the entire part. The electrostatic fluidized bed includes an integral control panel and utilizes the same power-supply unit as the manual electrostatic spray system.

Preheating the part is not necessary with this method. The electrostatic forces—negative or positive to ground—cause deposition of the powder on either hot or cold surfaces. If the surface is hot, the deposited powder will sinter and adhere upon contact. If it is cold, the electrical charge on the particle will hold it in place until it is post-heated to cause flow. An advantage of post-heating is that powder can be selectively removed, reducing or eliminating the need for masking.

Powder Characteristics

Factors affecting the application of powders in this process involve the types, sizes, and particle shapes of the powder material to be used. Generally speaking, types of powders proven acceptable for the electrostatic fluidized bed process are:

- Epoxy;
- Epoxy/polyester hybrids;
- Polypropylene;
- Polyethylene;

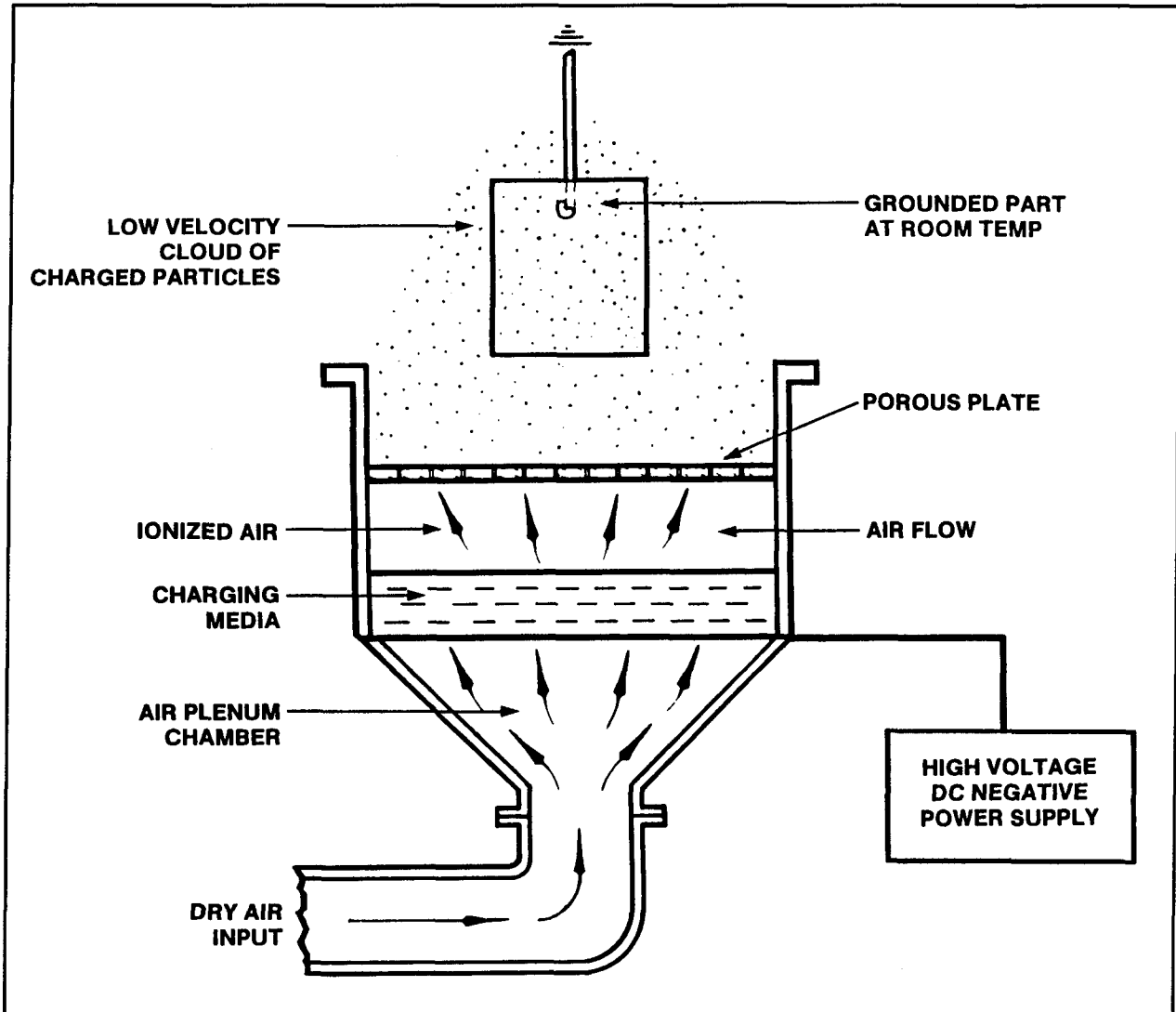

Figure 5-6. Electrostatic fluidized bed. (Source: Electrostatic Technology, Inc.)

- Acrylic;
- Polyester;
- Nylon; and
- Engineering thermoplastics such as PFA, PPS, PEEK PVDF.

Fluidization and transfer efficiency also are influenced by the particle size distribution.

Equipment Characteristics

There are basically two styles of electrostatic fluidized beds, those with electrodes immersed in

the powder bed and those with a remote charging media.

Locating the charging electrodes in the powder bed is effective, but it poses the hazard of arcing between the electrodes and the grounded substrate. The principal method for achieving powder charge is to locate the charging medium in a plenum below the powder bed, eliminating the possibility of arcing. Inlet air is ionized and the charge is passed to the powder during fluidization. The voltages employed with either method nominally are between 30 and 100 kilovolts. In most cases, negative polarity is used. Positive polarity may be of some benefit with nylon.

Chapter 5

The amount of current from high-voltage sources used with this technique is in the range of 200 microamperes. The current draw is independent of the amount of material being charged. It is related only to the proximity of the ground object to the charging media and to the resistive network used in the circuit. The amount of voltage applied to the charging medium affects the density of the charged powder cloud. The higher the voltage, the denser the cloud, and the greater the amount of deposited powder.

Other determining factors related to the amount of powder deposited are exposure time and distance above the upper surface of the aerated powder bed of the product to be coated. It will be evident that the deposition rate lowers as the part is moved away from the charged powder.

A common concern with all electrostatic deposition techniques is the "Faraday Cage" effect, which can cause a poor powder build, especially inside acute angles. The electrostatic fluidized bed has been employed successfully in challenging applications such as coating the slots in motor armatures for insulation purposes.

With the electrostatic fluidized bed, powder particle-sized classification is not experienced to any great degree so long as deposition takes place near the upper surface of the bed. However, the further one moves above this point, the more pronounced the classification becomes.

Safety Considerations

Safety concerns vary, depending upon the design of the coating unit. The electrostatic fluidized bed design {with the charging medium in the plenum} is known to be a safe design, with no potential for an arc between the charging medium and a grounded part.

Definite safety factors must be carefully considered when using an electrostatic fluidized bed that has electrodes in the powder bed. Since the charged cloud density is extremely high, design of the high-voltage source is very important. The output voltage should be approximately

100 kilovolts maximum and the maximum output energy (joules) when the unit is shorted to ground must not be greater than the ignition energy of the particular materials being applied. Also, output regulation of the supply—rate of fall of the output voltage with current draw increase—must allow rapid overcurrent protection.

An important consideration when using the exposed electrode bed with preheated parts is that the parts being coated must not be heated excessively in the preheat oven. When the parts being coated are too hot, gasses and vapors can be released within the bed causing the air between the part and the electrode to become conducting, creating a sparking condition between the part and source.

It is good practice to employ an exhaust system with the exposed electrode type bed. Top exhaust, entrance and exit port exhaust, or perimeter exhaust are all applicable techniques. Velocity of exhaust air should be a minimum of 50 FPM (15.24 m/min). The same collection and recovery devices employed with electrostatic spray can be used with this technique.

Design and Application

Several electrostatic fluidized bed designs are available, but some may be controlled by various patents. All use the same basic concept of employing the fluidized portion as a material supply reservoir for the charged powder cloud. An arrangement typical of these devices is shown in Figure 5-7.

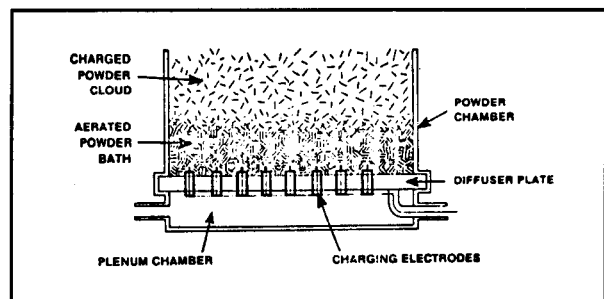

Figure 5-7. An electrostatic fluidized bed design with electrodes in powder bed.

The plenum chamber, diffuser plate, and power chamber must all be made of an electrically insulating material. Normally, rigid PVC or polyester reinforced fiberglass is used for the plenum and powder chamber and either high-density porous polyethylene or porous ceramic for the diffuser plate. The supporting framework can be of steel construction.

The fluidizing air used in conjunction with this process must be dry and free from such contaminants as oils, silicon, etc. Normally air at a pressure of 2 to 10 PSI will be required at a rate of approximately 5 CFM per square foot of diffuser plate. A suitable air drier must be used in conjunction with the air source, either compressor or blower.

Sample Application

The electrostatic fluidized bed is used for a variety of substrate types. This includes linear materials such as small parts, wire, cable, screen, and coil products such as steel. The electrostatic fluidized bed in a production environment is usually combined with other processing systems into an integrated powder coating machine. An example of such a machine is illustrated in Figure 5-8.

The illustrated machine is designed to coat motor armatures with an insulating film of epoxy. Parts are loaded onto a conveyor that rolls the armature forward through the system. This

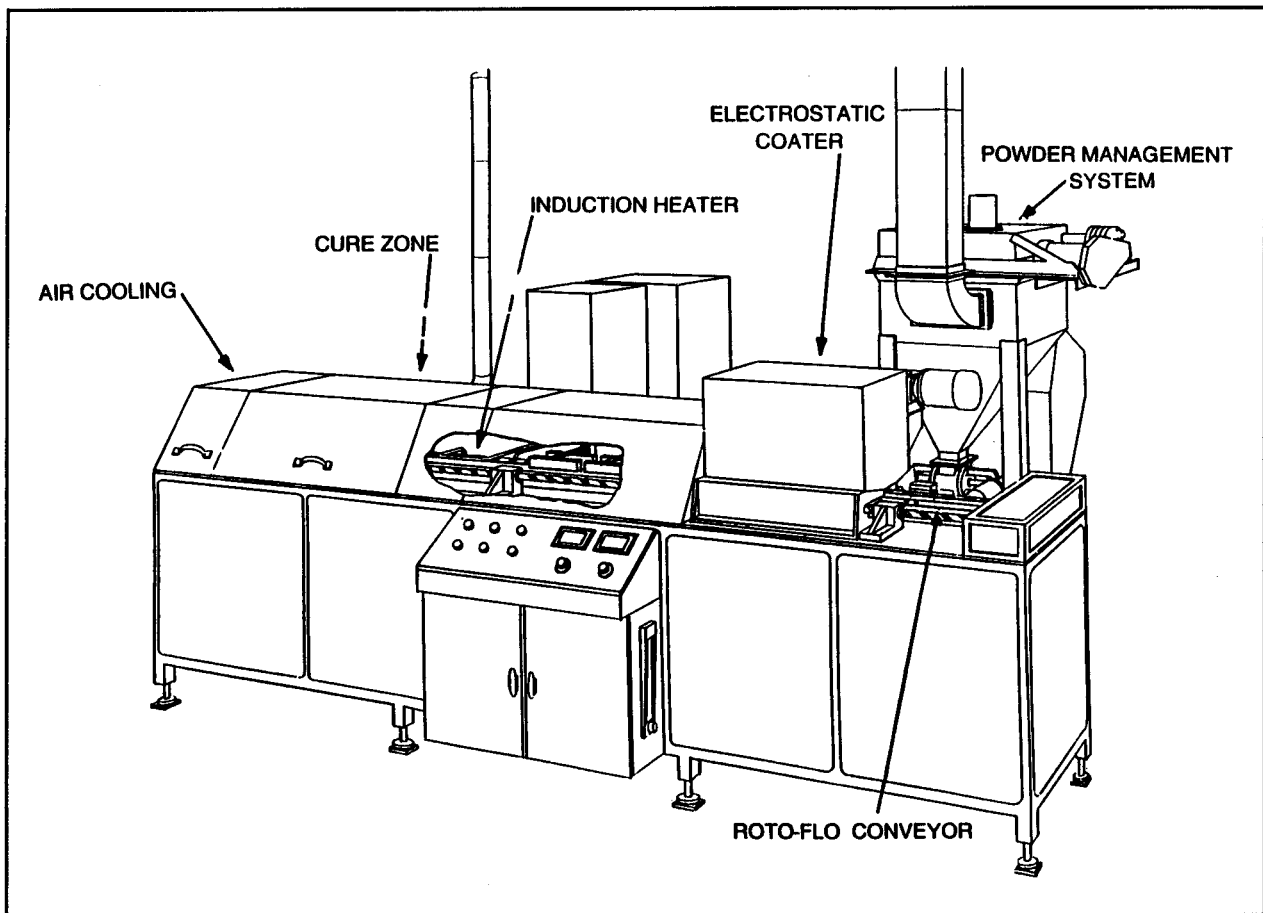

Figure 5-8. Electrostatic fluidized bed in a production environment is usually combined with other processing systems into an integrated powder coating machine.

Chapter 5

method of conveyance therefore presents a constant distance from the powder bed to the surface to be coated, on this cylindrical part. As the part is coated at essentially room temperature, the powder can be selectively, automatically removed from surfaces not to be coated, eliminating the need for masking. To attain high throughput rates, induction heaters are used to quickly raise the temperature of the part. The part is then passed through a convection zone for cure completion, and finally air cooled.

ELECTROSTATIC POWDER SPRAY COATING

Electrostatic spraying is the most widely used method of applying powder coating materials. Its growth is increasing at an impressive rate. Developed in the mid '60s, this process is the most efficient means of applying coatings and finishes in a short time. However, acceptance of powder coating in general was initially very slow in the U.S. In Europe, the electrostatic powder spray concept was accepted more readily, and the technology moved much faster there than elsewhere in the world. However, many advances were made in both powder materials and application equipment available to U.S. manufacturers. These advances generally involved problems associated with electrostatic powder spray coating, as well as improving functional operations of system components. As a result, there is a wide variety of electrostatic powder spray coatings systems available in the United States today.

To apply powder coating materials with the electrostatic powder spray process, five basic pieces of equipment are needed:

- Powder feeder unit;
- Electrostatic powder spray gun, or equivalent distribution device;
- Electrostatic voltage source;
- Powder recovery unit; and
- Spray booth.

There are other devices to enhance the operation of these basic components.

In the operation of an electrostatic powder spray system, powder is siphoned, or pumped, from a feeder unit through a powder feed hose to the spray gun(s). Spray guns direct the powder toward the part in the form of a diffused cloud. Propelling force is provided both by air that transports powder from the feeder unit to the spray gun, and by the electrostatic charge imparted to the powder at the gun. Electrostatic voltage is supplied to the spray gun by a source designed to transmit high-voltage, low-amperage electrical power to an electrode(s) attached to the spray gun. As the diffused, electrostatically charged powder cloud nears the grounded part, an electrical field of attraction is created, drawing the powder particles to the part and creating a layer of powder. Overspray—or powder not adhering to the part—is collected for re-use or disposal. In the collector unit, powder is separated from the conveying airflow. Collected powder is then automatically or manually recycled back to the feeder unit to be resprayed. Air is passed through a filter media device into a clean-air plenum and then through a final, or absolute, filter back into the plant environment as clean air. The coated part is then carried from the application area and subjected to heat, which results in the flowout and curing of the powder material.

Economic Advantage

With electrostatic powder spray, up to 99% of the powder overspray can be recovered and reapplied. Material loss experienced with powder is minimal in comparison to liquid coating systems.

In addition, in most cases powder provides one-coat coverage without runs and sags on the finished part. Applying a primer coat prior to the finish coat is unnecessary, reducing time and labor required by multicoat liquid systems.

Reduced fuel cost in curing powder often results from the use of smaller ovens, shorter oven times and, in some cases, lower oven

Methods of Applying Powder Coatings

temperatures. There is no need to heat or temper booth makeup air since air is returned to the plant environment as clean air.

Other cost savings, including lower clean-up costs, can be attained with powder. There is no need to mix, recover, and dispose of solvents when coating with powder. Usually, no solvents or chemicals are used in cleaning either the powder application equipment or the spray booths. Since air and vacuum cleaners are generally all that is required for cleaning with powder, labor and cleaning materials are reduced, and disposal of hazardous paint sludge is eliminated.

A large percentage of liquid coatings is comprised of sometimes toxic and flammable solvents that are lost in the application process. Shipment, storage, and handling costs of solvents are usually very expensive. With powder, costs involving air pollution control equipment, flash-off time, and solvent waste disposal are virtually eliminated.

Eliminating solvent usage also can reduce fire insurance requirements as well as rates paid to maintain fire insurance protection.

Finally the applied cost per mil per square foot of film is equivalent to, or lower than, liquid coating costs in most cases.

Ease of Application

The consistent finish characteristics and electrostatic "wraparound" realized in powder spray applications help reduce the need for highly skilled operators. In addition, there is no viscosity balance to maintain when coating with powder. Powder materials come "ready to spray" from the manufacturer.

No flash-off time is required with powder. The coated part can be transported directly from the spray area to the oven for curing. Reject rates can be reduced, as can costs involved in reworking rejected parts. Runs and sags are usually eliminated with the powder coating process. Insufficient or improper coating can be blown off the

part (before heat curing) and recoated. This can eliminate the labor and costs involved in stripping, rehandling, recoating, and recuring rejected parts.

Users are finding that the powder spray coating process is easily automated. It can utilize automatic gun movers, contouring mechanisms, robots, and stationary spray gun positioning.

Total production time can often be reduced, or production volume increased, with powder spray coating. Eliminating various steps required with the liquid coating process can result in a more efficient finishing line.

EQUIPMENT

Most electrostatic powder spray coating systems are comprised of four basic pieces of equipment—the feed hopper, electrostatic powder spray gun, electrostatic power source, and powder recovery unit. A discussion of each piece, its interactions with other components, and the various styles available is necessary to understand the functional operation of this process.

Powder Feeder Unit

Powder is supplied to the spray gun from the powder feeder unit. Usually powder material stored in this unit is either fluidized or gravity-fed to a pumping device for transport to the spray gun(s) (Figure 5-9). Newly developed feed systems can pump powder directly from the storage box.

The pumping device usually operates as a venturi, where compressed or forced airflow passes through the pump, creating a siphoning effect and drawing powder from the feed hopper into powder hoses or feed tubes, as shown in Figure 5-10. Air is generally used to separate powder particles for easier transporting and charging capabilities. Volume and velocity of the powder flow can be adjusted.

In most cases, the feeder device utilizes either air, vibration, or mechanical stirrers to aid in

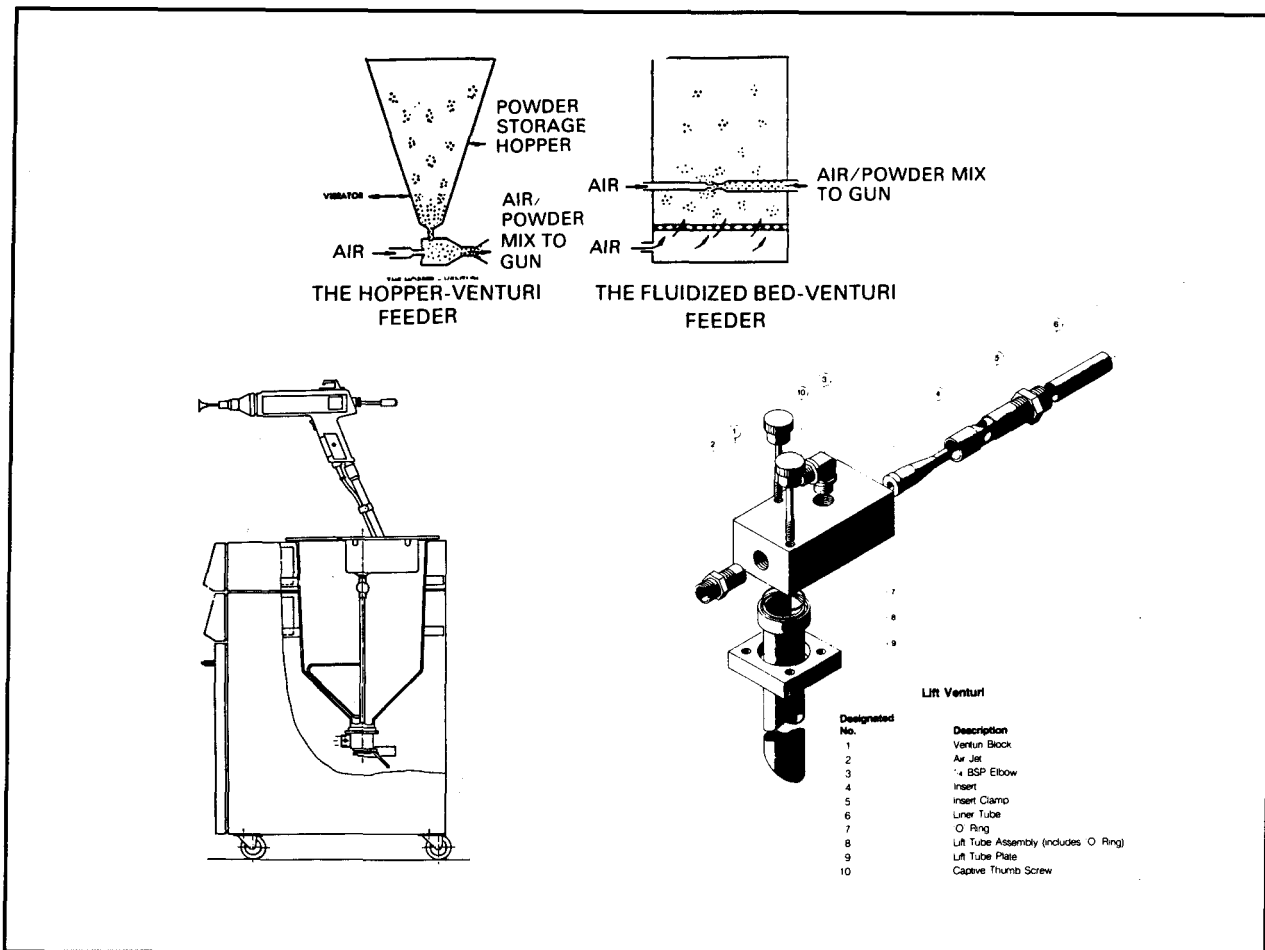

Figure 5-9. Typical types of powder feed devices. (Sources: Ransburg-GEMA and Volstatic, Incorporated.)

“breaking up” the powder mass. This action results in much easier transport of the powder, while assisting in regulating the volume and velocity of the powder flow to the spray gun(s). Independent control of powder and air volumes aids in attaining the desired thickness of coating coverage. The powder feeder is capable of providing sufficient material to one or more electrostatic spray guns several feet away. Powder feeders are available in many different sizes, with selection depending on the application, number of guns to be supplied, and volume of powder to be sprayed in a specified period of time. Generally constructed of sheet metal, the feeder unit can be mounted adjacent to, or even be an integral part of, the recovery unit.

Feeder units, which utilize fluidizing air to facilitate pumping of powder material to the spray

gun(s), are designed similar to the fluidized bed concept. Compressed, or forced, air is supplied to an air plenum generally located at the bottom of the feeder unit. Between the air plenum and main body of the feeder unit is a membrane, usually made of a porous plastic-composite material. Compressed air passes through it into the main body of the feeder unit, where powder material is stored. The fluidizing action of the air results in lifting the powder material upward, creating an agitated, or fluidized, state (Figure 5-2). With this fluidizing action, it is possible to control the metering of powder siphoned from the feeder unit by the attached, or submerged, venturi-style pumping device (see Figure 5-9).

When gravity feed-type feed units are used, the operation involves a conical or funnel-shaped unit in which powder material is stored. Pumping

devices attached to this type of feeder unit usually are of a venturi-type pump. In some cases, vibration or mechanical stirrers are used to enhance powder siphoning by the venturi effect produced by the pumping device. Powder is gravity fed to the pumping devices, and fluidizing of the powder is not necessary. Again, see Figure 5-9. Powder may also be delivered directly from powder boxes or containers using a double-well siphon tube, which provides enough local fluidization to allow uniform delivery.

Sieving devices are sometimes used in conjunction with feeder units to screen out any dirt, clumps of powder, and other debris, and to condition the powder prior to spraying. These sieves can be either mounted directly to or above the feeder unit to facilitate easier flow of powder

within the closed loop of powder delivery, spray, and recovery (Figure 5-11).

OPERATION

Feeders

Since the feeder is the first step in delivering powder to the part, it must be well set up and maintained. Poor operation at the feeder will result in noticeably deteriorated performance in the downstream equipment.

Air used to fluidize and pump the powder must be clean and dry. Oil, moisture, rust, and scale can contaminate the powder and even block the pores in the fluidizing plate. This in turn can lead to poor fluidization or even a ruptured plate.

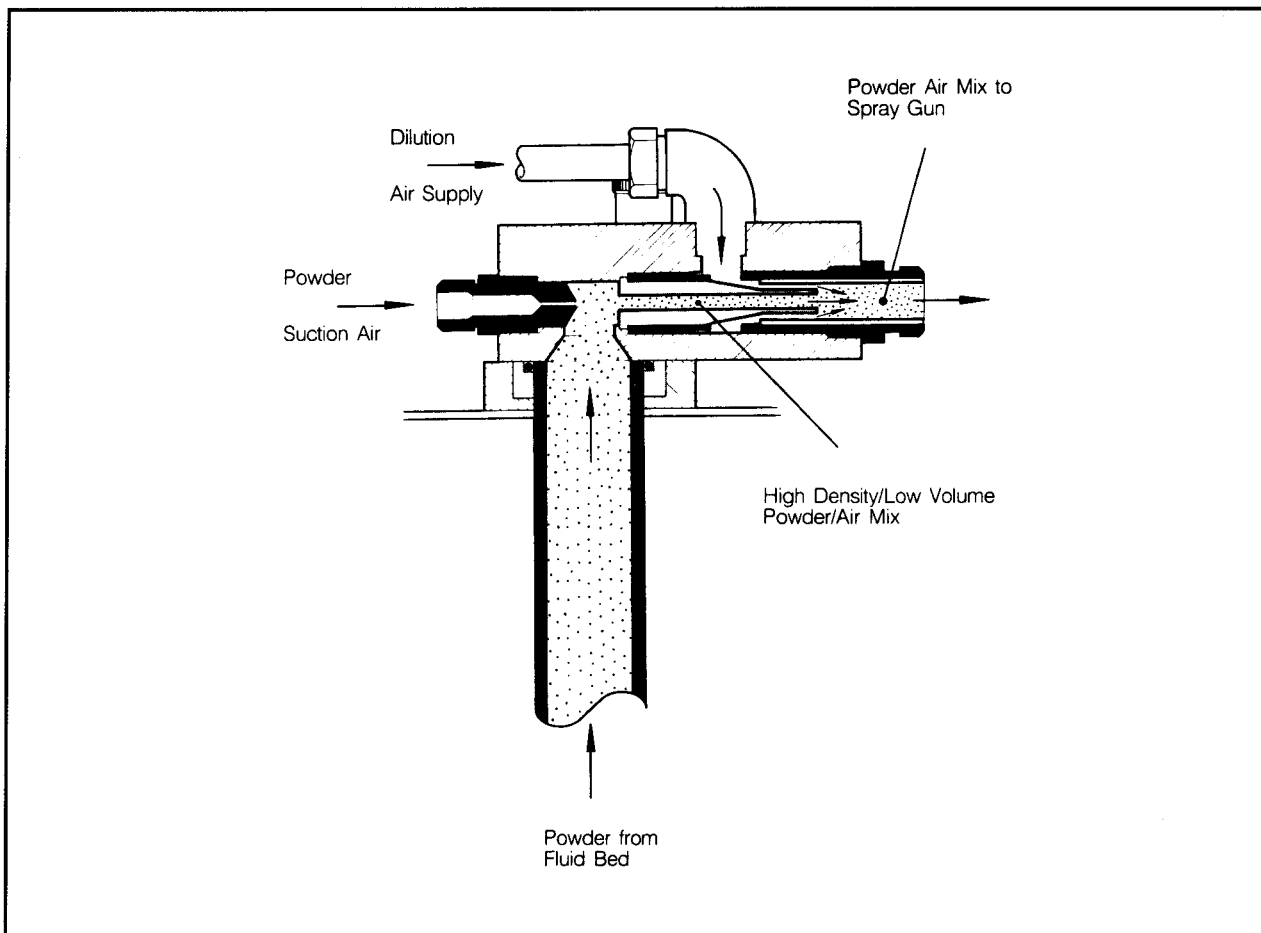

Figure 5-10. Venturi cutaway view from side. (Source: GEMA/Volstatic, Incorporated.)

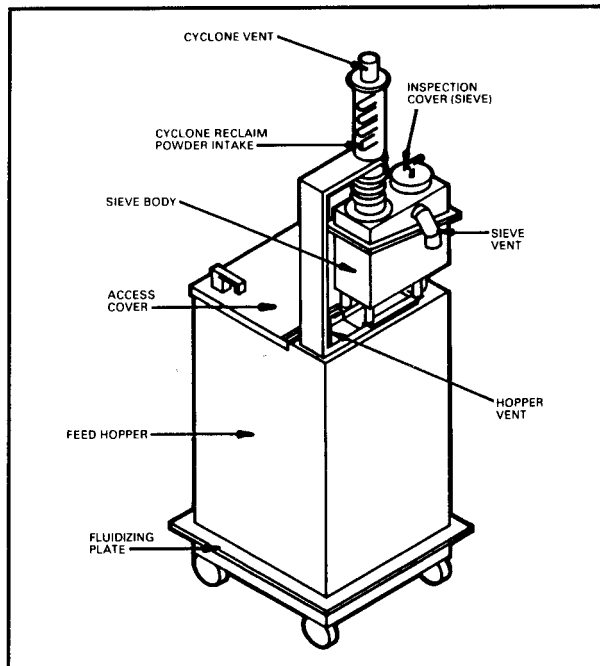

Figure 5-11. Powder feed hopper with sieving device attached. (Source: Nordson Corporation.)

The hopper must be properly vented to reduce pressure buildup. Poor venting can affect fluidization, and can cause fugitive powder to leak into the workplace, creating housekeeping and safety problems. The hopper must also be electrically grounded (earthed) to prevent static electricity buildup. In fact the National Electric Code requires that all “dead” (not an active part of a circuit) metallic and conductive components in an electrostatic spray system be grounded. See NFPA-33.

The feeder should be securely mounted or designed in a manner that effectively prevents it from tipping over and spilling powder into the workplace.

Pumping devices used to convey powder from the feeder to the powder spray gun(s) should be inspected and cleaned on a regular basis. Parts exposed to high-velocity streams of powder are prone to wear and/or impact fusion. Worn parts result in loss of performance and control of the painting process. Impact fusion causes blockage and reduced flow rates. Impact fusion is a sintering process in which the powder grains become fused together in hard, tightly bonded, deposits on the walls of powder passages. Ten-

gency to impact fuse is related to the velocity, the directness of impact (blunt versus grazing impact), wall material, and the nature of the specific powder. A good preventive maintenance program is essential to a properly operated powder system.

Sieving devices mounted on the feeder unit must be free of debris, and screens must be kept clear of powder buildup. Proper venting of the sieve is critical as the performance deteriorates if there is much differential pressure across the screen.

Powder Delivery Hoses

A key part of the powder’s path on its way to the part being painted, the powder hose is often overlooked. Hose routing should be as direct as possible, with hoses trimmed to eliminate excess length. Routing should also avoid sharp bends or kinks. A bend radius of 9 inches (22 cm) is considered good practice and will help reduce wear, impact fusion, and pressure drop. Frequent inspection for internal wear, external chafing, and impact fusion is important.

A variety of material can be used in powder hoses, the choice being based on flexibility, kink resistance, freedom from tribocharging (static buildup due to powder flow), resistance to impact fusion, lack of chemical interaction with the powder, and wear resistance. Since there are many parameters to balance and many types of powders available, there is no “best” material.

Electrostatic Spray Guns

Electrostatic powder spray guns impart the electrostatic charge to powder particles, and shape and direct the pattern of those particles on the way to the part. The gun controls the deposition of powder on the parts through variations in gun position, velocity and shape of pattern, and charge levels.

Powder spray guns are available in both manual (hand-held) and automatic (fixed mount) types, in internal and external charging, corona charging with internal or external high-voltage

supplies, and in triboelectric (friction charging) types. All of these variations have their own benefits and weaknesses, and their own role in the painting of parts.

Internal and External Charging Guns

In these guns, powder is charged by ion bombardment in a region close to the charging electrode. A high voltage of 30-to-100 kilovolts (kV) and usually negative polarity is applied to the charging electrode. This voltage creates a very strong electric field around the electrode, which in turn causes a breakdown (ionization) of the air around the electrode to form a corona discharge and an ion current. The ions are directed by the field to the powder particles, which are bombarded by the ions, transferring charge to the particles. The charged particles are then carried to the parts primarily by air currents and, to a lesser degree, by the electric field forces. Once the charged particles come close enough to the part being painted (within about 1 cm) the attraction between the charged particle and the grounded part causes the particles to effectively deposit on the part.

Regardless of the type of gun being used, the transport of well-charged particles to within 1 cm of the surface is essential for efficient and effective painting.

The external corona gun is by far the most common type in use today, and is well suited for flatware and high line speeds with good uniformity and high transfer efficiency.

Performance on Faraday Cage areas has improved over the years, with attention to careful pattern control and gun placement. The much more effective flat spray pattern is now used by approximately 80% of all automatic guns.

Since performance on Faraday Cage areas depends on getting powder into the cavity, success is ultimately determined by pattern control and aerodynamics—the transportation means, rather than concentration on the electrostatic effects. The older conventional wisdom of turning the gun voltage down to help penetrate a

Faraday Cage is ultimately counterproductive since the powder will be less well charged and less able to deposit on the part if it does succeed in getting into the cavity. Keeping the voltage as high as possible and working on the aerodynamic aspects of the transportation maintains a higher charge level on the powder and results in more efficient and effective coating of the cavity.

The rate or thickness of deposition is controlled by powder flow rate, position of the spray gun, pattern used, velocity of the powder stream, line speed, part geometry, and the level of charge on the particles. Characteristics of the powder being sprayed can also affect deposition. Important factors are: type of material, mean size, and probably most important, shape of the distribution curve.

Internal Charging Guns

In an internal charge corona gun, the charging process is by ion bombardment, the same as in an external charge gun. However, while the charging electrode is referenced to the grounded part to form the corona in an external gun, the internal charge gun carries its own ground reference internally. The results of this are little or no external field forces, and little or no excess ion current. The reduced field will help penetrate the Faraday Cage (cavities) areas since the external field provides a small diverting force that tends to move particles away from the cavity. It is well to remember that transporting powder into the cavity is almost entirely an aerodynamic process. The reduced ion current diminishes the tendency toward back ionization, which leads to smoother surface finishes with fewer “cratering” or “star-ring” defects. Reduction of back ionization also reduces self-limiting effects of electrostatic powder coating and allows heavier film builds in the 10-to-15 mil range, which is difficult to achieve in external charge systems.

Internal charging corona guns tend to require more frequent maintenance than other types owing to the necessity of keeping their ground reference clean and free of powder, and because of their complex and often fragile components.

Triboelectric Charging Guns

Triboelectric guns have no high-voltage powder supply. They work by arranging the internal geometry so that air, when conveyed, rubs powder grains on the walls of the gun, transferring charge by frictional means. Polarity of charge is almost always positive. If tribo guns are used with corona guns, the corona guns should be obtained in positive polarity as well.

Generally, deposition rates are lower for tribo guns, requiring more guns per line. However, some of the better modern designs can achieve flow rates and charge levels comparable to external corona charging guns, given a favorable powder. Since the charging process depends on inertial forces bringing the particles in contact with the walls, and since the charge transfer is related to the relative chemical compatibility of the powder and the wall material, the process is sensitive to both the particle size distribution and the chemistry of the powder being sprayed. Many powder companies have addressed this issue, and lack of suitable tribo powders is less of a problem. There are, however, powders that cannot be sprayed via tribo—for example, some metallic dry blends. Also many colors may not work unless specifically formulated for tribo application. It is imperative that the user coordinate with his or her coating suppliers when tribo guns are used.

Since there is no external electric field and no excess ion current, the tribo gun has all the benefits associated with internal charging corona guns, but without their stringent maintenance requirements and internal complexity.

Internal Versus External Power Supplies

In corona charging guns (either internal or external charging), the high-voltage power supply may be located either internally or externally. There are tradeoffs inherent in both designs.

The internal supply receives low-voltage power from an external control unit through a thin,

flexible, lightweight cable. The internal generator steps this low voltage up to the required 30-to-100 Kv in the gun. In an external supply, the high voltage is generated externally and carried to the gun in a thicker, stiffer, heavier high-voltage cable.

Placing the generator in the gun has benefits with regard to the cable, but adds weight to the gun, and—in hand guns particularly—places restrictions on the designer to keep the high-voltage generator light and compact. Also, in applications where collisions with parts or machinery can occur, or in high-temperature environments, there is potential damage to a high-cost component if the generator is in the gun. Conversely, the external supply has no practical restrictions on size or weight and it is protected from damage.

Skilled design engineers can make both systems deliver equal performance in painting parts.

APPLICATIONS FACTORS

In addition to proper selection and set up of feeders, pumps, hoses, and spray guns, a number of other factors can affect the end result. Foremost is the role of the powder itself, especially the powder's particle size distribution.

Accumulated experimental evidence and experience indicate that the shape of the distribution curve, rather than the particle size per se, is the best indicator. A histogram of the particle-size distribution should show a narrow peaked shape. Broad, flat distributions with large percentages of both coarse and fine particles will show a number of undesirable properties, including poor fluidization, lower transfer efficiencies, and rapid buildup of fines. It is believed that the presence of coarse particles inhibits effective charging of finer particles. Where smoother, high gloss finishes are desired, finer grind powders are often required. However, it is important that not only the mean size, but the shape of the distribution curve, be adjusted.

In tribocharging guns, the powder plays a critical role operating the gun. While dry-blend additives can enhance tribocharging, best practice is to alter the melt-mix to achieve a homogeneous material.

In the past, conductivity was thought to be an indicator of chargeability in powders. Today, there is no evidence that this is the case.

The tendency of powder coating to limit the film build and promote more uniform coatings has been shown by John Hughes of the University of Southampton, England to be caused by back emission of ions from the deposited film. These ions act to discharge the incoming powder and to prevent its deposition. Back ionization is also responsible for orange peel, cratering, and starring defects in the film. Back ionization can be overcome by moving the guns further away, reducing the voltage, using an internal charge gun (either tribo or corona), or by applying the powder in thin layers with 10-to-15 seconds "relaxation time" between applications. Powder chemistry and particle-size distribution are also involved.

Although it is true that the powder spray process is dependent on electrostatics, and without charged powder we do not have a process, the powder spray process is only about 50% electrostatics. The other half depends on air flow to shape the patterns and transport charged powder to the parts.

Faraday Cages are areas where there is, by definition, no electric field from an external source. Under close examination, it can be seen that the cavities referred to as Faraday Cages are also zones where it is difficult to achieve air flow. These are difficult areas to get powder into for aerodynamic reasons. If you cannot blow powder into a space, that space cannot be coated. The older conventional wisdom of "reducing the voltage to overcome a Faraday Cage" is actually treating the symptom, not the underlying disease.

"Wrap" is also spoken of as an electrostatic phenomenon. And to be sure, without charge there is no evidence of wrap. But it is not electro-

statics that transports powder around to the back edge flat panel or the backside of a round tube; aerodynamic turbulence provides the transportation.

Managing booth air flow, and selecting the correct nozzle or pattern shaping device, advantageous gun placement, and pump settings all contribute equally to the electrostatic effects.

OPERATION CONDITIONS

For electrostatic powder spray guns to function properly and safely, the following conditions should be maintained:

- If metallic, fixed powder spray guns must be adequately grounded at their points of support to reduce the possibility of static charge buildup on the gun and the discharge of this static charge to a part or component in the spray area.
- Manual powder spray gun operators must be adequately grounded (usually through the gun handle) to prevent buildup of a static charge on the operator's body during spray operations.
- Powder spray gun parts that come into physical contact with moving powder must be inspected and cleaned on a regular basis. Parts contacting moving powder are prone to wear (if the powder material is abrasive) at high velocity and impact fusion. Worn parts result in poor control of powder flow, accentuated impact fusion, and more frequent cleaning. If a part is obviously worn, it should be replaced.
- Electrostatic powder spray guns (manual and automatic) should be checked periodically to determine the level of electrostatic charge being imparted to the powder material. The lack of, or decrease in, expected electrostatic charge indicates a problem in the electrostatic system and should be corrected as soon as possible. To reduce the possibility of electri-

Chapter 5

cal shock, troubleshooting guides should be utilized when inspecting or repairing any component within the electrostatic system.

- With fixed or automatic powder spray guns, interlocks should be used to rapidly de-energize the high-voltage elements involved with electrostatic spray under any of the following conditions: stoppage of ventilating fans or failure of ventilating equipment from any cause, stoppage of conveyor carrying goods through the high-voltage field of electrostatic spray, and other conditions as prescribed by regulatory agencies.
- The electrostatic power unit must be adequately grounded.
- Electrostatic power units must be installed in a manner consistent with conditions specified by regulatory agencies.
- Electrostatic power units should be inspected periodically to determine the level of electrostatic kilovoltage output.
- Troubleshooting guides provided by the manufacturer should be strictly followed, to reduce the possibilities of electric shock.

CHAPTER 6

POWDER SPRAY BOOTHS AND RECOVERY SYSTEMS

Efficient recovery of oversprayed material is one of the most important aspects of an electrostatic powder spray system. Of the quantity of powder leaving a spray gun, 30 to 90% adheres to the part. The oversprayed material must be collected effectively and recycled by a recovery system in order to achieve the high system efficiencies characteristic of powder coating applications.

Air movement is the primary tool in virtually all methods of collecting over-sprayed powder materials. Collection systems must address several important requirements:

- Containment of overspray in order to limit worker exposure and minimize housekeeping;
- Efficient separation of powder from air volumes;
- Ease and time of color change;
- Control of air movement in spray zones for augmentation of application transfer efficiencies;
- Minimization of operational noise levels for worker protection;
- Safety and insurance agency approval regulations, particularly in the areas of fire and explosion prevention;
- Ease and time of installation; and
- Comfort and convenience for the worker during system operation.

Recovery systems can be as simple (Figure 6-1) or as sophisticated (Figure 6-2) as the application requires. Whatever the application, a proper design based on a sound understanding of the applicable physics and engineering fundamentals is essential to the efficiency and longevity of the system operation.

SPRAY BOOTHS

An important element of the spray booth is the material of which it is constructed. Typically, booths are constructed of polypropylene, stainless steel, or coated steel panels. Some booths are a combination of materials. One unique design utilizes retractable polyethylene sheeting. Selection criteria include: effect on transfer efficiency (whether the booth material is conductive or non-conductive), cleanability (how strongly the powder is attracted to the booth wall), visibility in the spray area (translucence of the material), as well as strength, durability, and repairability given the size of the booth and specifics of the application.

Parts openings in a spray booth should be sized properly to allow clearance for the largest part to be coated. Openings for automatic and manual spray stations should allow sufficient access and be properly positioned for best coating efficiencies. Accommodations must be made for the induced air flows associated with spray equipment. Booth walls around such openings should be configured and contoured appropriately to minimize "dead zones" in the spray area where powder can build up.

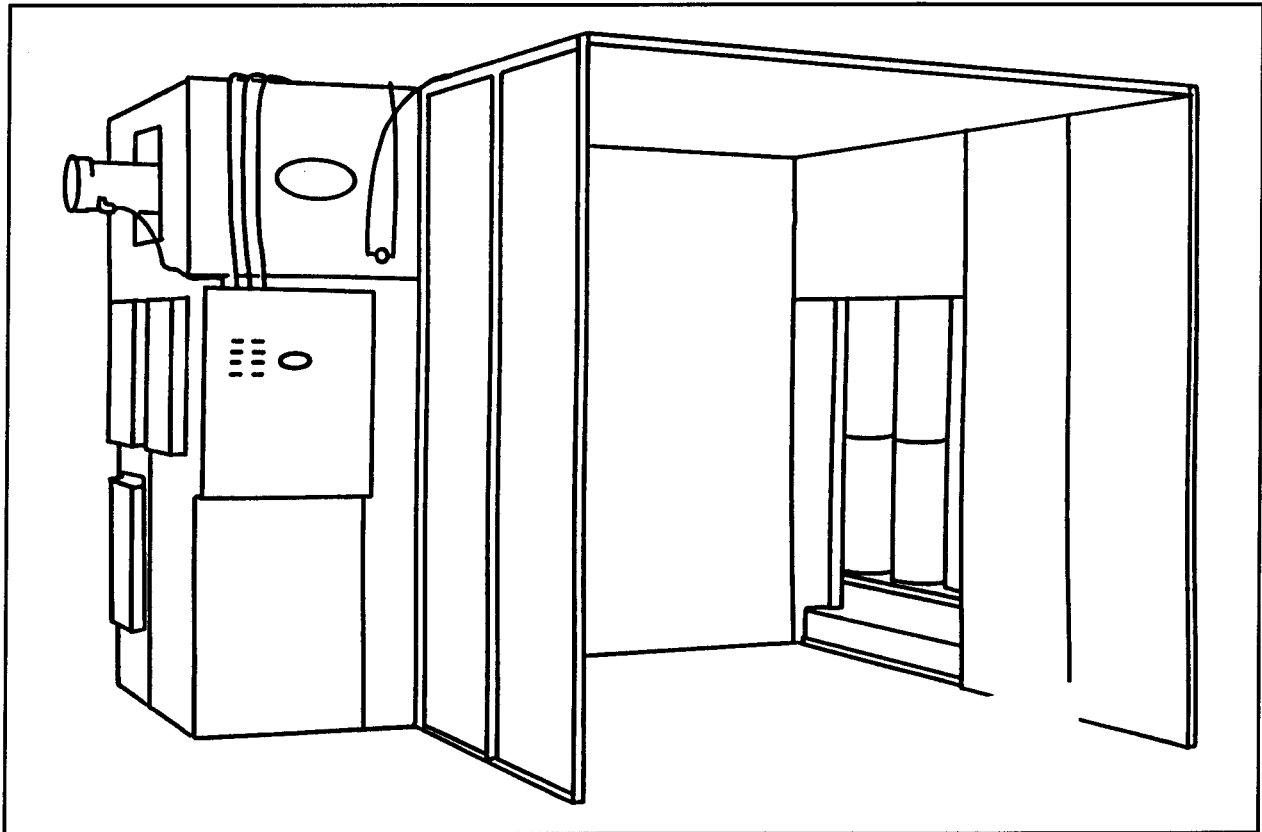

Figure 6-1. Batch booth with no quick color change.

Gravity-assisted Booths with Cyclone Recovery

In this system, about 50% of the overspray falls back to the feed hopper by gravity. The balance is collected through an extraction duct to the reclaim system. In this system, the reclaim system is a virtually self-cleaning cyclone separator with reclaim recovery efficiencies from 90 to 95%. The small fraction of powder remaining in the air stream, from the cyclone, is separated in the final filter before the air is returned to the powder coating room. Figure 6-3 is only one of several possible configurations of this equipment. Typically, painted cold-rolled steel or stainless steel is used to construct the booth cabin walls. The use of an efficient coating chamber with a self-cleaning cyclone allows an unlimited number of color changes without duplication of filtering equipment.

In gravity-assisted recovery booths, a portion of the overspray returns directly to the feed hopper by gravity without entering the reclaim system. This minimizes the amount of reclaim powder generated within the system (Figure 6-4). This booth design lends itself to be used with a variety of products (e.g., facets, lawn mower decks, housings, castings, etc.). The products coated are usually arranged on a rack or "hanger" used in conjunction with an overhead conveyor.

Quick-color Change Booth with Cyclone Recovery

This spray booth design has replaced booth walls, metal and/or rigid plastic, with indexing thin plastic sheeting (Figure 6-5). When a color change is desired, pneumatic air motors index clean booth walls. This eliminates manually cleaning down the booth walls for a new color

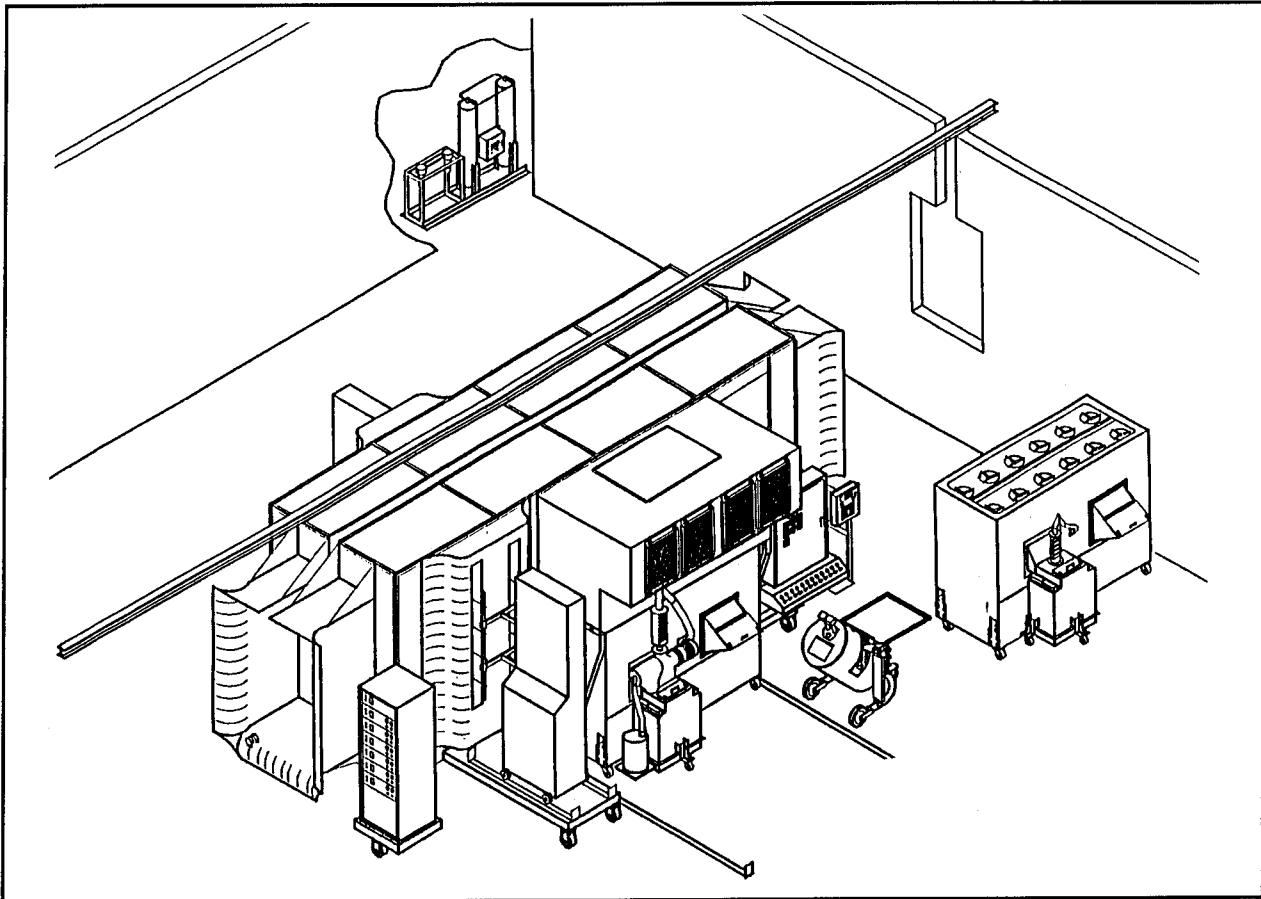

Figure 6-2. Conveyorized booth with multiple color modules that allow quick color change.

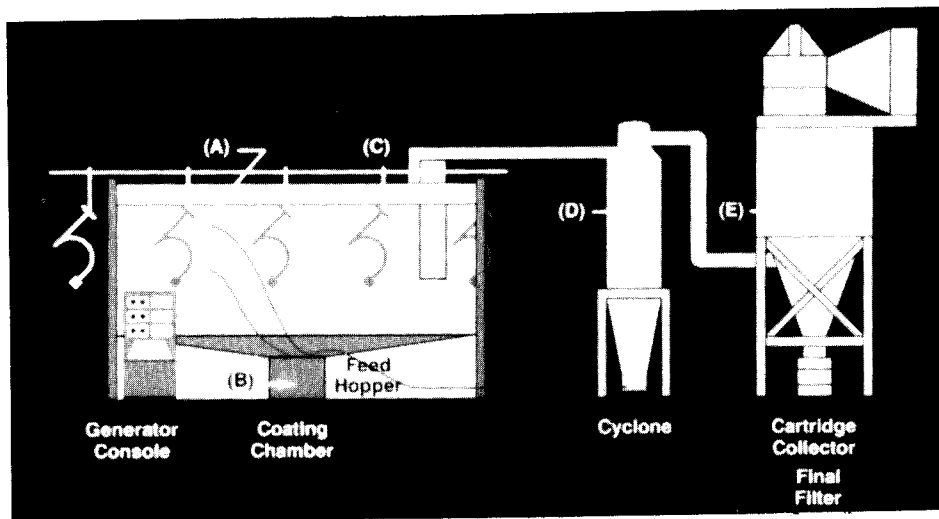

Figure 6-3. Basic components of an electrostatic spray coating system. (Source: Volstatic, Incorporated)

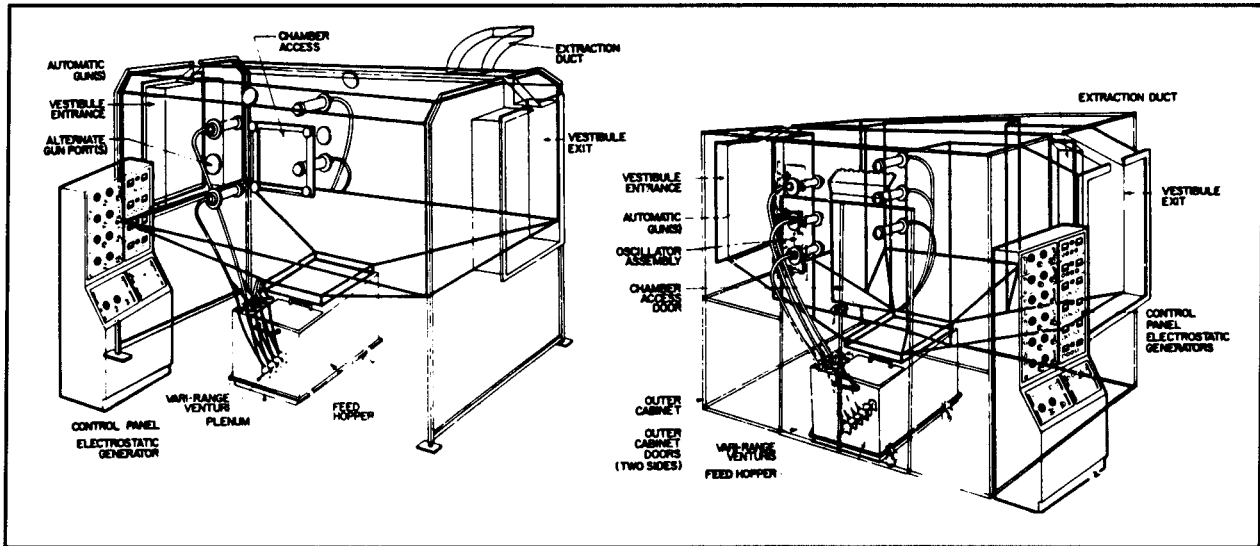

Figure 6-4. Variations of gravity-assisted recovery type booths (Source: Volstatic, Incorporated)

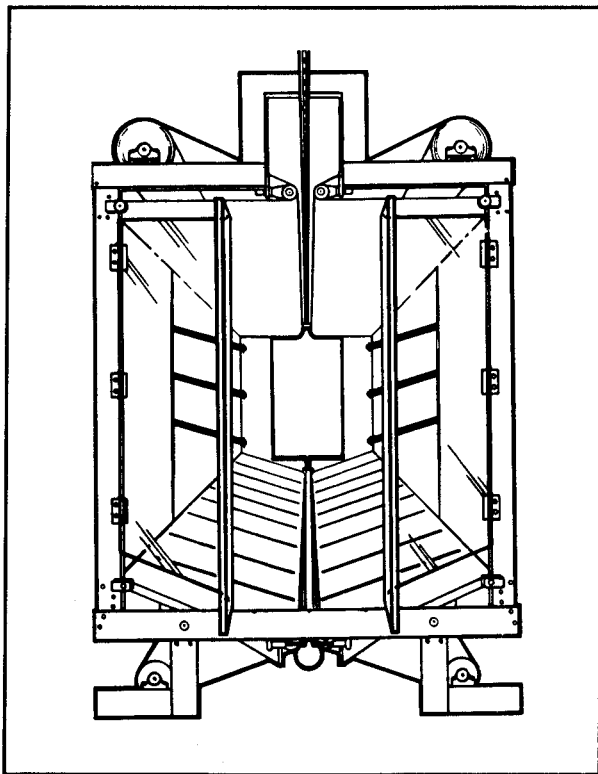

Figure 6-5. This spray booth, whose ceiling, walls, and floor are made of indexing thin plastic sheeting, requires less downtime for booth cleaning.

and allows the spray booth to change colors in 1 to 2 minutes. Once the new plastic is in place, operator openings and/or automatic gun slots are simply cut out where needed.

This style spray booth can be used with either a cyclone reclaim system or a cartridge module system. There is a variety of products used with this booth, and an overhead conveyor is used to transport the product through it.

Rigid Booth with Cyclone Recovery

In contrast to gravity-assisted booths, this booth sends all the other spray through the cyclone collection system and the detached powder feed system.

Other Booth Technologies

Horizontal Coating Booth. Typically, this booth is used to powder coat a product that requires coverage on all surfaces except one. The surface area to be masked is placed face down on the conductive conveyor belt, which not only transports the parts through the spray booth, and provides the necessary ground for the part. It also serves as an automatic mask. When appropriate, this system helps to eliminate the cumbersome tasks of masking and racking. Parts may be manually or automatically loaded and unloaded, and even use some type of automatic vibratory feeder for loading (Figure 6-6). This booth

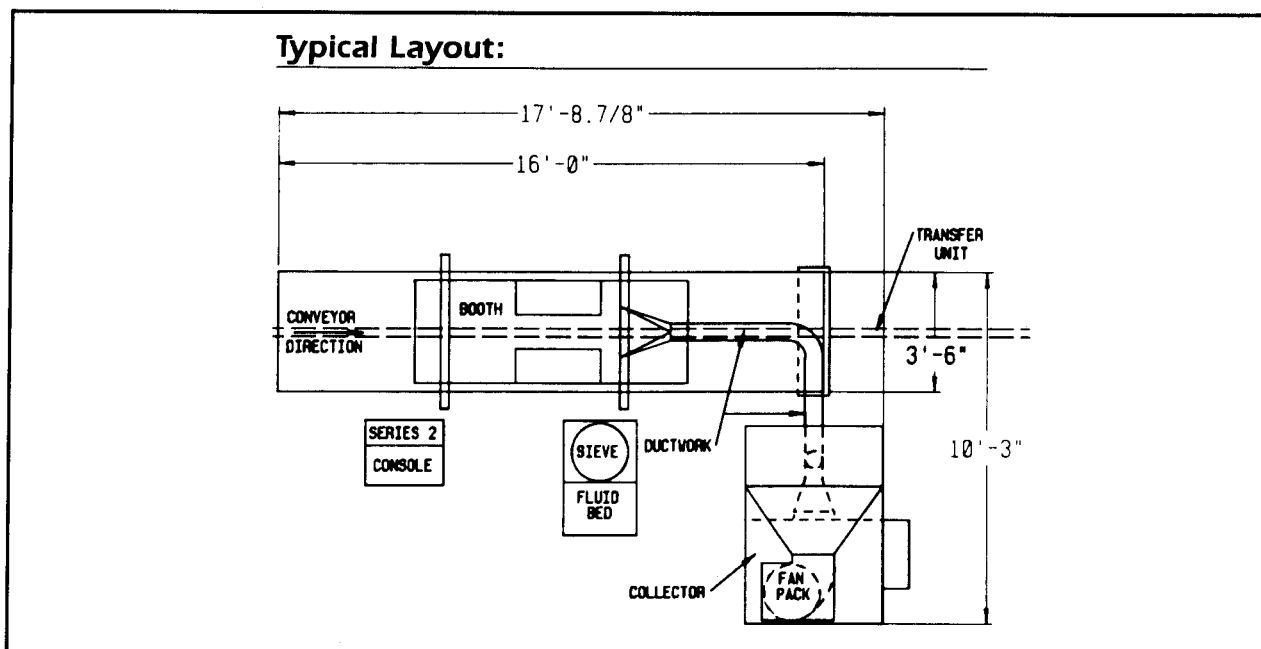

Figure 6-6. Horizontal coating booth can help eliminate the cumbersome tasks of masking and racking.

design can be used with types of products such as disc brake shoes, washers, nuts, etc.

Belt Booth. This is another type of application booth employing a moving belt in the bottom of the booth (Figure 6-7). Construction of this booth system includes a fabric belt traveling in a horizontal loop along the booth floor.

Oversprayed powder is drawn to the belt surface by the airflow created by the booth exhaust system. Powder particles trapped on the surface of the belt are vacuumed off by a pickup head located at the end of the booth. Once removed from the belt, the powder is sent through the reclaim system to be separated from the vacuum airflow and prepared for re-use. Like some of the other booths, this booth can be used with a variety of products and with some type of overhead conveyor.

Chain-on-edge Booth. This type of booth has a cartridge filtration for recovering the powder and is used to coat products passed through on a spindle conveyor. The conveyor for this booth is floor mounted and uses a pressurized shroud to keep powder off the conveyor as the parts are coated. Types of products using a chain-on-edge

booth are: oil filters, motor housing, cans, bulbs, bottles, etc. Most of these parts are NOT complex in shape and are rotated through the booth to be coated.

COLLECTOR SYSTEM

The powder collection system must maintain sufficient velocities through the booth openings to contain oversprayed powder material. Accordingly, size of the collection system is dictated primarily by square footage of the booth opening. Systems for collecting, separating, and processing over-sprayed powder typically incorporate one or more of the following techniques. Two types of cartridge spray booths are utilized, depending on the size of the part being coated and the number of guns.

Self-contained Booths

One type of application system is a self-contained spray booth and collector. Air used to contain and recover oversprayed powder is filtered through primary and final filters and returned to the plant as clean air. Solid state

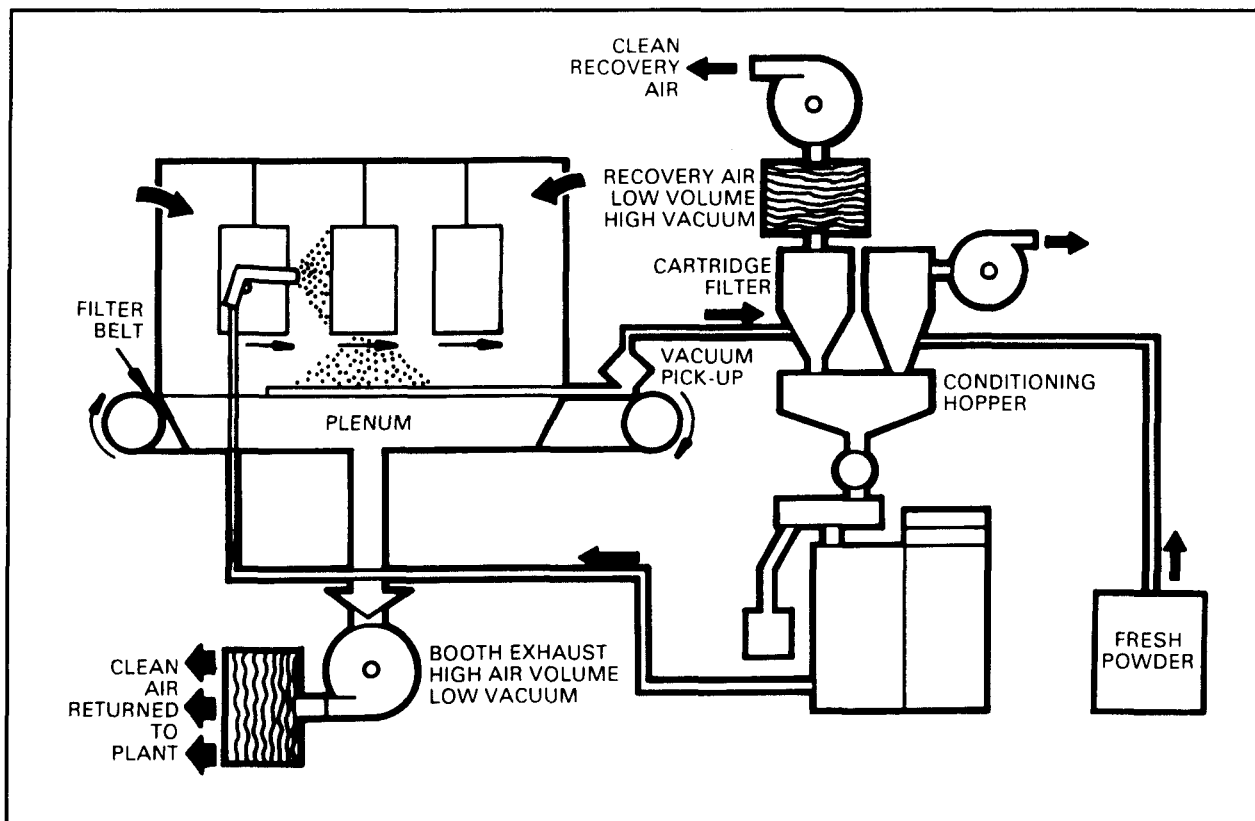

Figure 6-7. This belt booth uses a moving belt to assist in recovering overspray powder material. After air from the belt draws overspray to the surface, a vacuum pick-up transfers the powder to a cartridge-type collection device for recycling.

controls for filter cleaning and powder recycling provide fully automatic reliable operation.

The “downdraft” design of the booth locates the filter/collector module directly below the spray booth for maximum operating efficiency in most coating applications. The downward air flow allows oversprayed powder to naturally wash down over the part, resulting in more consistently uniform coating and improved operating efficiency.

The downdraft design also provides more efficient use of floor space and allows access to either side of the booth for automatic and manual spray gun stations. The collector module is easily removed to facilitate cleaning and maintenance and to ensure fast, easy color change.

Side Draft Spray Booth

In a side draft spray booth/collector (see Figure 6-8), the powder spray booth provides clean, efficient, and flexible operation in manual or automatic powder coating applications. Utilizing cartridge filter technology, it provides high material utilization and fast color change capability in a space efficient economical system.

The booth has a rollaway filter/collector module design. Vertically mounted, high-efficiency cartridge filters use reverse-pulsed air to prevent excessive powder buildup and extend cartridge life. With improved filter cleaning, the module provides maximum air flow throughout the coating operation for optimum system performance. The collector module’s quick disconnect

Powder Spray Booths and Recovery Systems

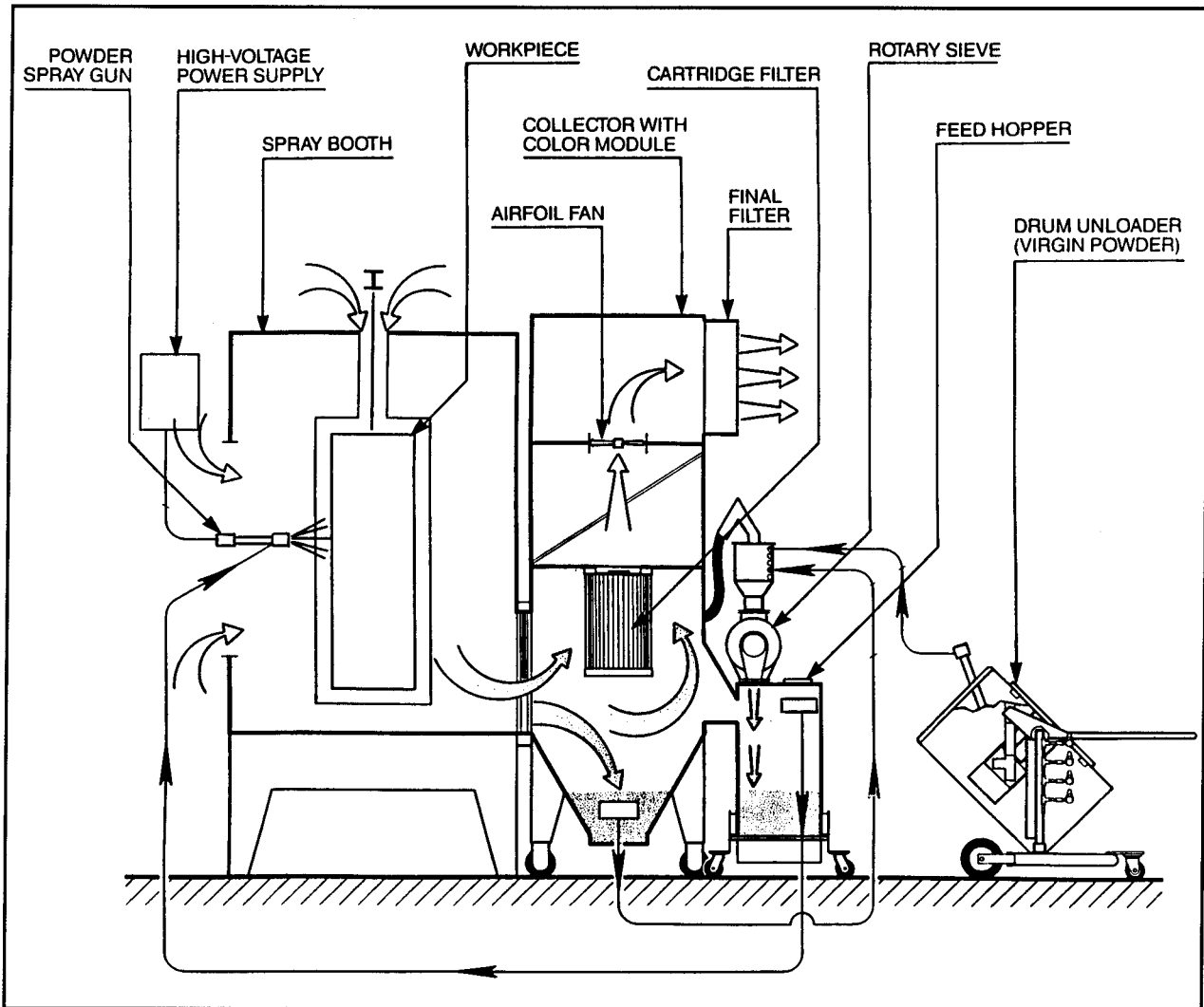

Figure 6-8. The efficient side draft spray booth delivers high material utilization and fast color change.

feature ensures easy access to facilitate cleaning and color changing operations.

A level sensing device in the external feed hopper automatically controls powder flow of recovered overspray from the collector back to the feed hopper on demand. This improves fluidization of powder material and ensures optimum coating performance.

Open Collector Cartridge Filtration

This is the most common and efficient method of overspray recovery in powder coating applications. Open collector refers to the open-face design of the collection unit (Figure 6-9) that eliminates the need for explosion venting. Powder is separated from an air stream, drawn through a cylindrical filter element. The powder is then removed from the filter element by a reverse air

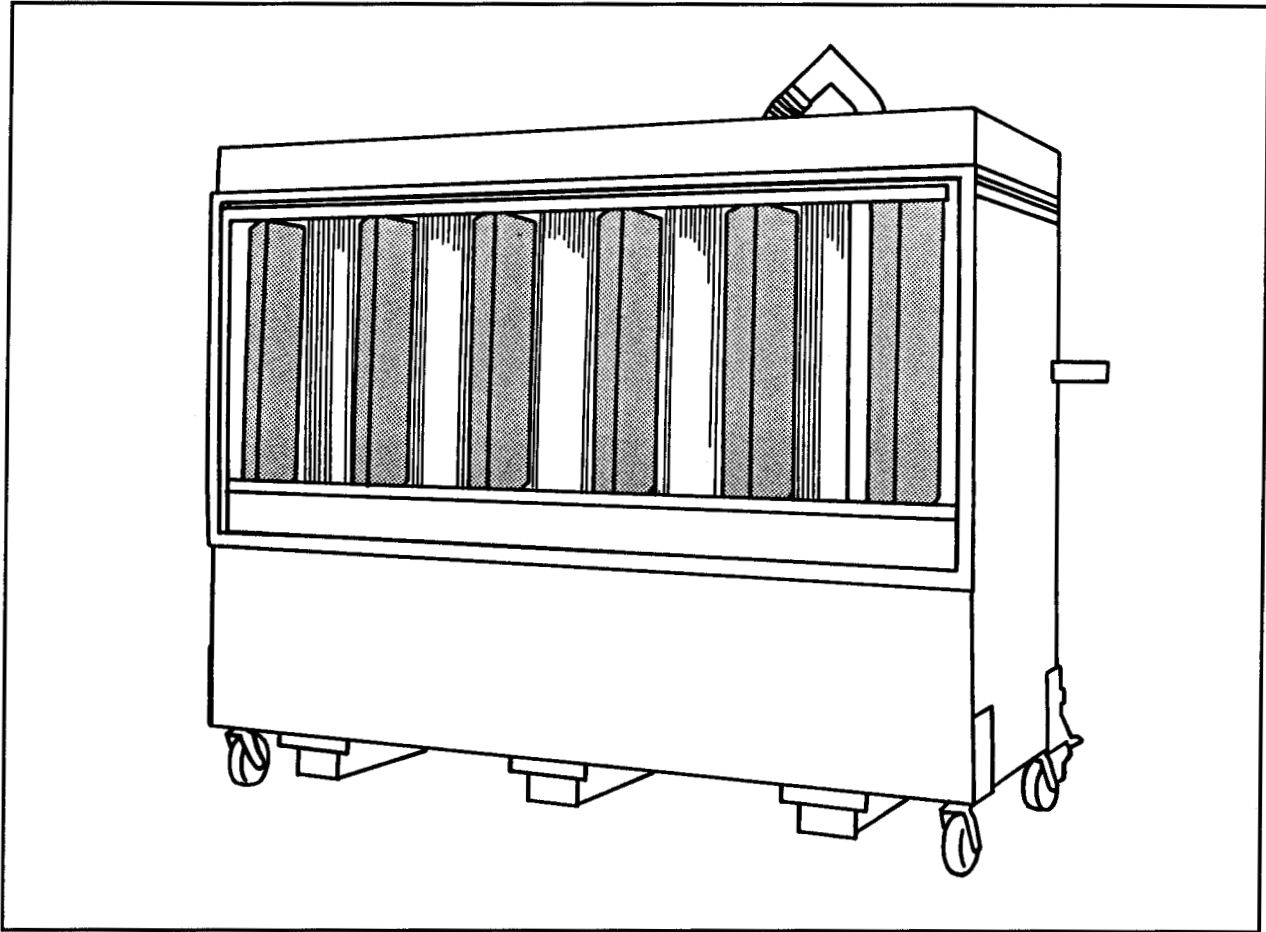

Figure 6-9. The open collector is so named because of its open-face design, which eliminates the need for explosion venting.

jet pulse mechanism. The powder ejected from the surface of the filter falls into a collection zone and is then processed for return to the spray equipment. The air drawn through the cartridge filters passes through a secondary high-efficiency filter, to remove any fine powder particles before the air is returned to the work environment. Efficiency of the cartridge filtration is a function of several key design elements.

For most efficient cleaning with minimal waste, the filter cartridge should be designed for maximum *effective surface area*. The traditional air-to-cloth ratio associated with bag filters is not an appropriate measure for pleated filter elements.

Depending on the quality of the design, some portion of a tightly pleated surface area may not be accessible in actual operation. Some filters are enclosed in a perforated metal screen to protect delicate paper media. This, however, can also reduce the effective surface area. With new high-strength polyester media, an open pleat design and the elimination of an outer screen are now feasible design elements (Figure 6-10).

Filter efficiency, as measured for a given powder particle size, and static pressure drop across a filter are the two important measures of potential filter performance. Powder formulation and media composition must also be considered.

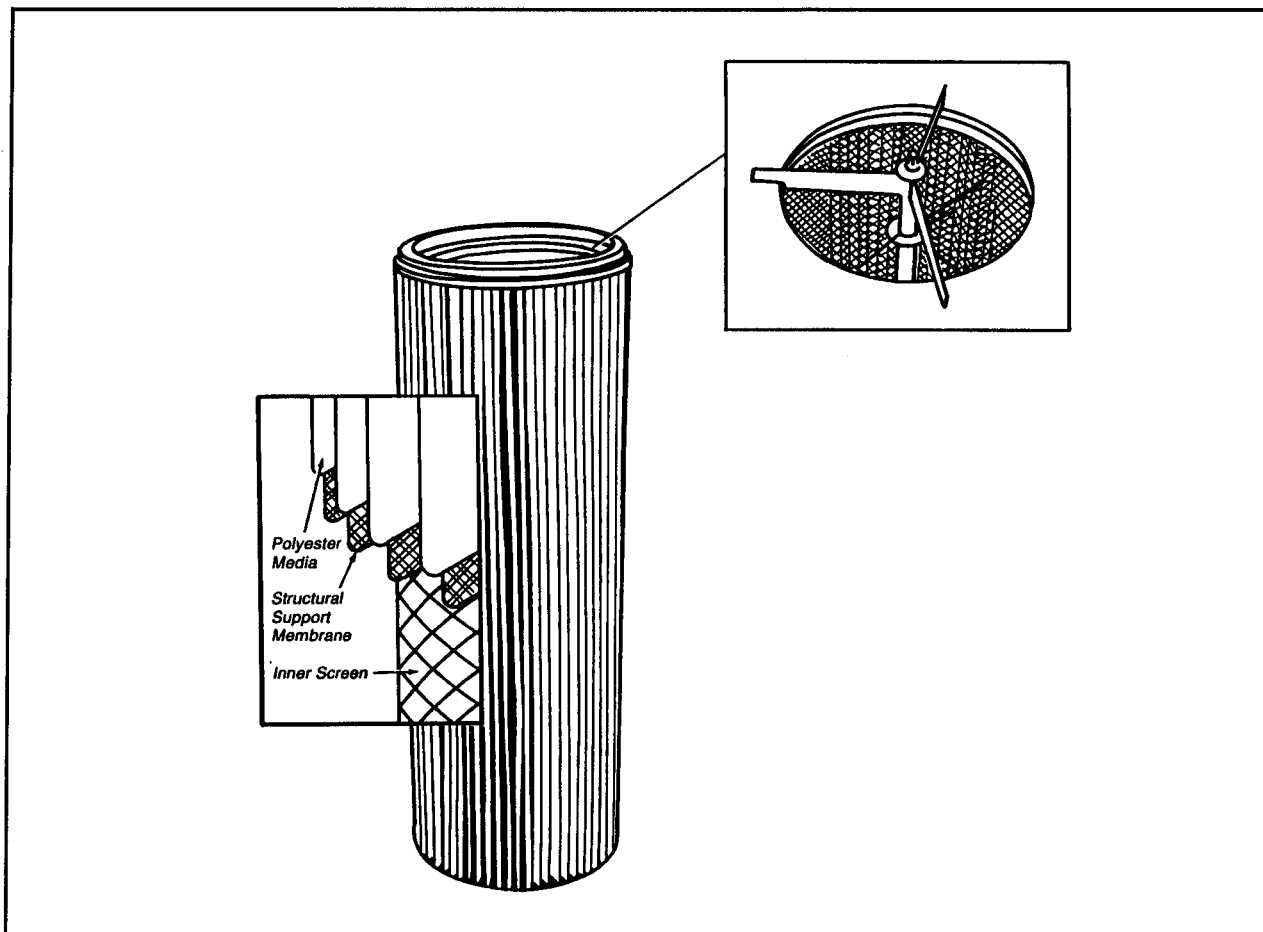

Figure 6-10. Filter cartridges are becoming more effective because of open pleat design and the elimination of outer screens. Making such innovations possible is the new high-strength polyester media.

Reverse-jet Cleaning Mechanism

A filter cartridge cleans as a function of the rate of pressure build-up inside a cartridge element. This build-up is induced by a jet of compressed air that fills the cartridge interior while sealing the cartridge opening. A well-designed cleaning mechanism is essential to the correct operation of a filter cartridge collection system.

Collector Inlet Design

Appropriate inlet design includes baffling for turbulence reduction and distribution of the

powder-laden air throughout the filter element population. This is important to assure minimal disruption of the spray region and full utilization of filter media.

Cartridge Mounting Arrangement

The best design for mounting filters minimizes the number of surfaces to seal and maximizes utilization of the filter media. The most common cartridge arrangement is vertically hung filters, either single or double stacked, in a side-draft module (Figure 6-11). This arrangement minimizes re-entrainment of powder on collateral filters following pulse cleaning. The side location

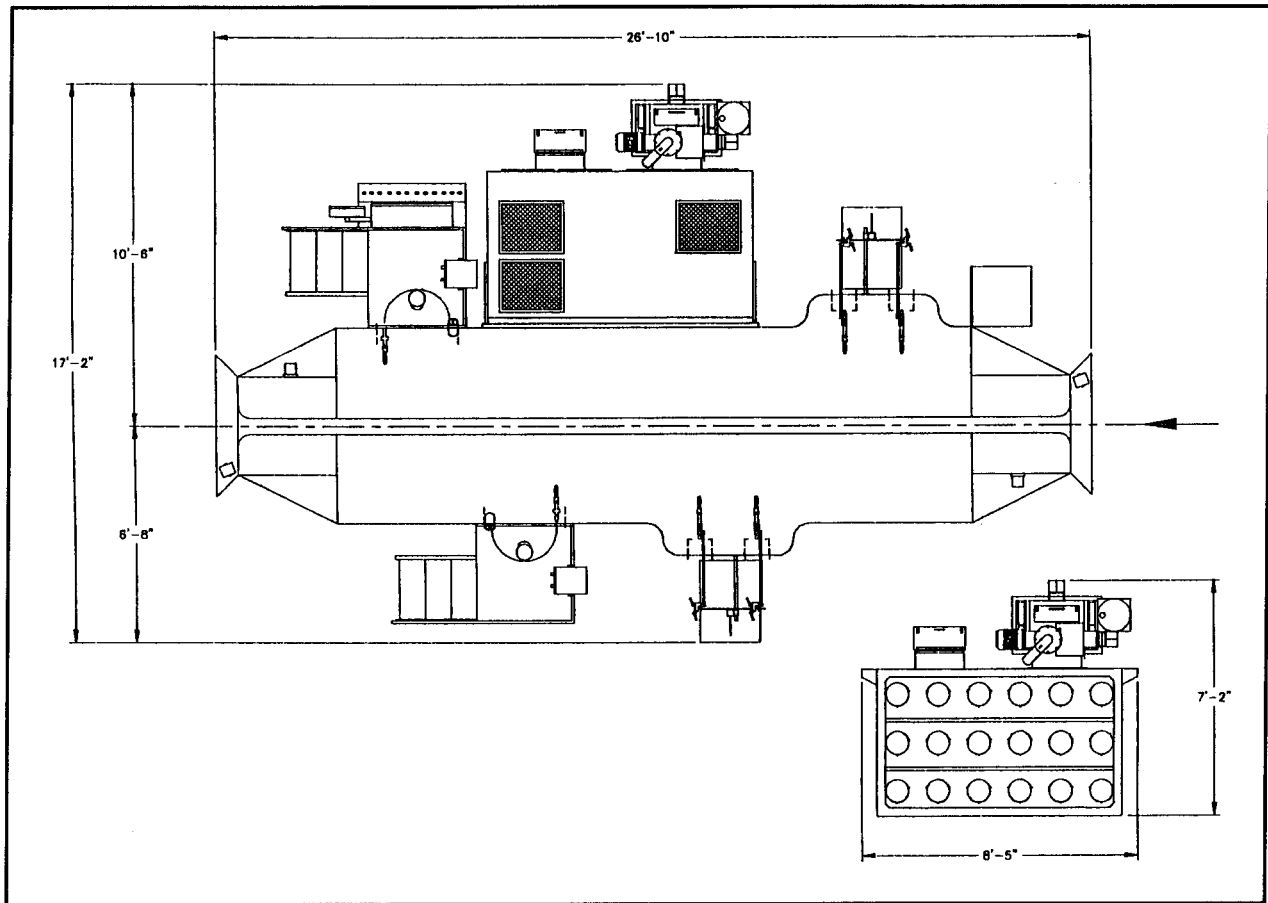

Figure 6-11. The most common cartridge arrangement consists of vertically hung filter, either single or double stacked, in a side-draft module.

helps reduce the height requirement of the booth floor. Cartridges can also be mounted horizontally (usually in stacks of two), either below the spray area in a down-draft arrangement or in a side-draft module (Figure 6-12). When filters are mounted horizontally in the side-draft module, sometimes the filter stacks are staggered to reduce the tendency for powder to be recaptured on a lower set of filters once released from an upper filter stack.

COLOR CHANGE CONSIDERATIONS

Color change in a powder system requires certain activities common to all types of equipment. Guns should be blown out using compressed air and, in some cases, require disassembly. Feed hose should be blown out or, in extreme color changes, replaced. Pumps or

injector blocks should be cleaned with compressed air. Booth walls must be cleaned, typically with a squeegee, by carefully wiping them down with the booth exhaust air in operation. Color change speed may depend upon the versatility of the reclaim system. Duplicate hoppers and sieves may be necessary to complete quick color changes. When time is not a factor or multiple booths are used, solitary reclaims are satisfactory, but all areas contacting the powder must be vacuumed or wiped.

One former major drawback to powder coating was the time required to change colors. However, equipment suppliers have made various design improvements to all aspects of the powder coating system to minimize the color change time. One approach is a duplicate powder coating line. When it is time to change colors, the system containing the current color is rolled off line,

Powder Spray Booths and Recovery Systems

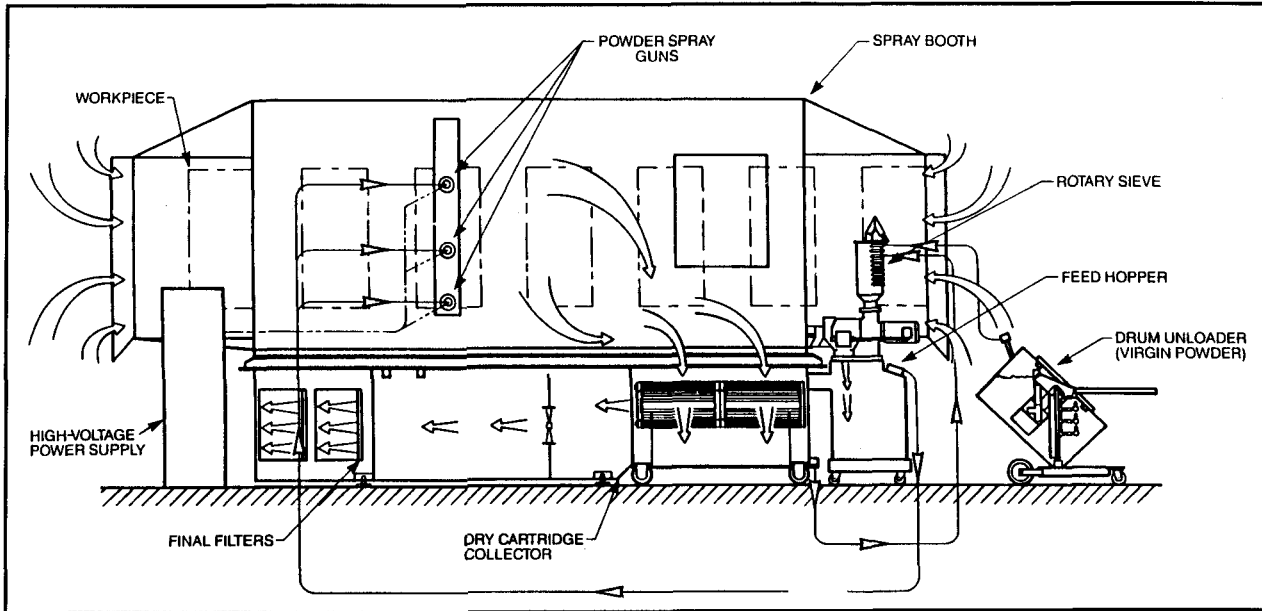

Figure 6-12. Cartridges can be mounted horizontally either below the spray area in a downdraft arrangement or in a side-draft module.

while the system with the next color is positioned on line. This allows the system in the off-line position to be cleaned in anticipation of any additional colors. The number of duplicate powder coating systems required depends on how many colors are sprayed and how frequently the color changes take place.

When color changing a single powder coating system, three areas require attention. First, the application equipment (generally consisting of the spray guns, powder hoses, injectors, and feed hopper) needs to be either cleaned or changed.

Second, cleaning down the spray booth interior is necessary to prevent any cross contamination of

the various powder colors. Caution should be exercised if compressed air is used to clean the booth interior. Air-blown powder may overcome the booth face velocity and migrate outside the spray booth. A rubber squeegee or damp cloth may be more desirable for the booth cleanup.

Finally, the recovery system must be prepared for the next color. The procedure for preparing the recovery system varies, depending on the style of the system. Equipment manufacturers have made design improvements in all areas of the powder coating system. Color change within a single powder coating system can be accomplished in minutes.



CHAPTER 7

DESIGN CONSIDERATIONS FOR OPERATION OF POWDER COATING SYSTEMS

Having the proper facilities is one of the most important aspects of a powder coating system for producing a consistently high-quality product. Being able to design the facility from the ground up is the ideal situation. Yet many systems must be installed within the available plant space.

In every locality, guidelines and parameters exist for air quality and liquid and solid waste disposal. These should be carefully reviewed with local regulatory agencies prior to designing the powder coating system. Such discussions may also have a bearing on site selection.

Factors inside and outside your facility make general location of the operation important. For example, even a properly designed powder coating booth can have failures that result in accidental migration of powder to the surroundings. Thus consideration should be given to ambient in-plant operations that could be affected by such a failure.

Outside, consider if any neighbors' exhausts will be detrimental to the powder coating processing and vice versa. A lumber mill may not be the best neighbor for a powder coater, but probably would be better than a cement plant. The same concept applies to the location of equipment within the plant.

The construction materials for an environmentally controlled room should be looked at in the following areas:

- Insulating properties: depending on the geographic location of the facility, the insulating properties of the construction materials could save a great deal of energy.

- Insurance ratings: the materials of construction can have a bearing on insurance rates for the building, and this could lead to a substantial saving on premium dollars.
- Surface smoothness: smooth interior walls lend themselves to easier maintenance, thereby saving labor.

Migrating powder from a system (though not usually a problem in a well-designed system) can occasionally become troublesome. A small amount of powder covers a large area if it is picked up by stray air currents. It accumulates over time on ledges and structural members. Enclosures with smooth walls and no catchall framework are desired for easy and best maintenance.

When making an equipment layout for a powder operation, the location of all elements should be carefully analyzed. Overhead framing can be avoided at this stage. It is best if exhaust from booths and ovens is direct. Conveyors are most easily mounted when positioned relative to adequate building structural members.

The relationships between the framing and exhaust from equipment are often overlooked. While some buildings have sufficient load factors built into the framing to support conveyors, others may not. Investigate the load factors before suspending anything from the framing.

The location of windows and doors in relation to spray booths and ovens is of great importance. Spray booths are designed to keep the powder within the booth and to provide uniform airflow

Chapter 7

as needed to transport the powder. A door or window opened next to, or in the vicinity of, a booth may completely disturb the booth airflow and cause difficulty. Powders may leave the booth, distorting the spray pattern, and drawing outside dusts onto the coating. Check with the equipment supplier on these points.

Although it is not always attainable, a controlled atmosphere for the coating booth and powder storage is very desirable. In some areas, this is necessary because of ambient conditions of temperature and humidity. Powder, if exposed, readily picks up moisture and is generally somewhat temperature sensitive. Operation will be improved if conditions can be standardized. Check with your powder supplier for special considerations.

Adequate consideration should be given to the availability and accessibility of all utilities. Energy is needed in a powder system to heat solutions and to cure the applied powder. Water is needed in the metal preparation stages. Disposal facilities must economically handle spent solutions and solids residual to the system. Every advantage should be taken of consultations offered by local utility and sanitation people. Be certain that you are aware of their services and they are aware of your needs.

OPERATION OF POWDER COATING SYSTEMS

Components of a powder coating system obviously rely on each other to maintain a safe and healthy operation. Proper operation of each component will ensure a safe and healthy working environment, and will result in maximum productivity. The following factors should be considered in operating and maintaining a powder coating system.

System Cleanliness

Powder introduced into the system should be as clean as possible, free of debris, moisture, oil, or other contaminants. Any contaminant in the

powder will land on the part, resulting in either rejection or rework. Also, the contaminant will be distributed throughout the system, contaminating otherwise clean material. Another consideration is that the contaminant could cause blockage, or "blind" the filter media, reducing the airflow through the system. Substantial reduction of airflow creates an unhealthy and unsafe atmosphere; powder containment capacity within the booth is reduced and powder could drift out into the work area. Also, as airflow decreases through the spray booth, the minimum explosion concentration of the powder being sprayed could exceed safe limits. (Most systems are designed with interlocks that disengage or shut the system down when airflow decreases to an unsafe or unhealthy level.)

Gages are normally provided with most powder coating systems. They indicate pressures across the face of the filter media and in the clean air plenum of the filtered air returning to the work area. Gages should be checked daily and, if possible, logged to be used as references for the safe operation of the system. In essence, air provided for the system should be clean, dry, and oil-free. Refrigerated air dryers will remove moisture from the air and should be included in any powder installation. Oil removal filters should be installed in the main air supply line to the system and checked or drained daily.

Another point to consider in maintaining cleanliness is the delivery and recovery equipment involved. To provide maximum efficiency, guns, pumps, hoses, feed hoppers, distribution hoppers, and any surface powder may encounter should be checked for cleanliness. Lumps of powder, impact fusion, debris, and worn powder contact parts block powder flow. Properly cleaned powder contact parts will prove most beneficial in controlling powder flow to and from the spray guns, and will reduce the frequency of cleaning. Parts not properly cleaned increase impact fusing and wear of parts. One note of caution: never clean powder contact parts with sharp or abrasive tools. A nick or scratch greatly enhances powder buildup on the part.

It is also very important to provide clean parts, hooks, racks, and conveyor. This enhances the electrostatic effect by ensuring a properly grounded part, and helps ensure a safe operation.

Operation of System Components

Proper design and construction are the first steps toward a successful and profitable powder coating system. Each powder coating system is unique in both design and application. Specifications the user provides to the powder equipment supplier determine the parameters of the system design. Information should always include all part dimensions, line speed, film-build requirements, types of hooks or racks to be used, conveyor height, dimensions of space provided for system installation, production schedule based on batch sizes and number of colors involved, and projected production requirements for the future. This enables the equipment supplier to design a system to exact specifications, for many years of utilization.

Information concerning the type of metal preparation and curing facilities also should be provided.

During the first few weeks of operation, the system should be monitored closely to determine its particular operating characteristics. These observations can be used to establish operating procedures for each product conveyed through the system for powder coating application. Remember, the system design is based on the largest part that will be coated and finished. Smaller parts may require adjusting the number of guns used, powder flow, electrostatic setting, proximity of the gun to the part, or any combination of these variances. By knowing in advance the precise settings and making these adjustments, excessive powder usage can be avoided and the desired efficiencies will be achieved.

A solid maintenance procedure based on daily, weekly, and monthly system preventive and corrective maintenance measures should be initiated. If this is done, the efficiencies necessary

to justify operation are easily attained. Some hints for maintaining system efficiencies are:

- Check oil and dirt-removal filters installed in air lines on a regular basis. Drain filters often and replace when necessary.
- Check operation of refrigerated air dryer at least once a week. Just because the air dryer is running, does not mean it is operating properly. Gages will indicate inlet and outlet temperatures of compressed air.
- Check powder contact parts periodically for wear. If the parts show excessive wear, replace them. Failure to do so will result in more time spent in cleaning the part to remove impact fusion, and will affect the system's operation. Never use sharp objects to clean parts. Always maintain a reasonable supply of spare parts.
- Check all ground connections on a regular basis. The loss of ground could affect the transfer efficiency of the spray guns, and a hazardous situation could be created if ground between workpiece and hanger is lost. Strip hangers on a regular basis.
- Check for pressure drops across filter media. A reduction in airflow through the booth could result in poor powder containment; an unsafe situation could be created if the minimum explosion concentration exceeds safe limits. Clean absolute filters on a regular basis. If absolute or final filters require frequent cleaning, it could indicate a ruptured or leaking filter media. The media should be checked and replaced if necessary.
- Clean booth daily with a squeegee or other grounded nonsparking device. Never use rags or paper towels to clean within a booth area. Lint could contaminate the powder material and create finish problems. More extensive cleaning should be accomplished on a weekly or bi-weekly basis.

Chapter 7

- Clean powder spray guns and feed pumps daily. Use an air hose to blow powder from the hoses, pumps, and guns. Visual inspection will reveal the need for additional cleaning or parts replacement. Be sure there are no loose hose connections between pumps and guns. All air line fittings should be secure. Locate feed hoppers as close to guns as possible to reduce hose length and the possibility for kinks or bends.
- Post maintenance procedures in areas where operators and supervisors will see them. Provide check-off lists for maintenance procedures.

Operational Health Hazards to Operators

Most powder coating materials contain a variety of substances to formulate the ultimate coating material. Some may pose health hazards to personnel within the immediate spray area. Pigments, curing agents, polymers, and fillers all present potential health hazards if permitted to escape the spray containment area. Such hazards can be caused by improper ventilation or by improper handling or use of the powder. OSHA regulations, applying to user and supplier, govern both the handling and use of powder coating materials. A Material Safety Data Sheet must be provided by the supplier, advising the user of any hazards associated with the powder coating material. Recommended precautions concerning skin contamination and respiratory exposure are normally documented in the Materials Safety Data Sheet.

The following recommendations should be considered to reduce potential health hazards associated with powder coating materials.

- Gloves and dust masks should be worn by personnel involved in handling the powder material. They are needed when opening fresh material containers, dumping material into supply hoppers, cleaning or performing

maintenance on equipment, and/or disposing of empty material containers. Powder, when exposed to the skin for extended periods of times, can dry the skin.

- Facilities should be provided for proper washing of skin exposed to powder materials. Soap and water are considered to be the safest and most effective means of cleansing skin exposed to powder. Personnel should be encouraged to wash with soap and water frequently. It is certainly necessary before eating, drinking, or performing normal body functions. Skin reactions can occur in some cases when exposed to powder and should be treated by frequent washing. Cleansing the skin with organic solvents should never be encouraged.
- Exposure to respiratory inhalation should be prevented through the use of respirators or masks. Also, proper ventilation of the powder spray system is important to prevent exposure to respiratory inhalation. Proper ventilation also maintains an environment safe from explosions by minimizing the possibility of ignition from static electrical sparks or other ignition sources. (NFPA 33, Section 13-5 specifies and establishes proper ventilation guidelines.) The safest operating procedures specified for powder spray applications are also the most productive.

The electrostatic powder coating process is somewhat different from the more conventional means of applying product finishes (such as "wet spray"). This is a method of applying electrically charged powder material to grounded parts. Powder is held to this part by the electrostatic charge imparted to the powder during the spray process. To ensure attraction and transfer efficiency, two conditions must be met. First, the part being sprayed must be properly grounded. Second, the electrostatic spray equipment must be functioning properly. If either of these conditions is not met, the net result is poor transfer efficiency and, in the case of a poorly grounded part, ultimately an unsafe condition.

Safety should always be incorporated into operating and maintenance procedures for the powder coating system. These procedures should consider all aspects of operation including:

- Storing and handling powder materials;
- Spraying parts within the spray booth;
- Conveying parts through the spray booth;
- Cleaning and maintaining equipment;
- Troubleshooting equipment;
- System start-up and shutdown;
- Reading, calibrating, and setting control gages and regulators;
- Recording daily critical ventilation pressure readings;
- Responding to alarms, interlocks, and system safety oriented control devices; and
- Disposing of waste materials

Guidelines for proper safe operating procedures are provided by the National Fire Protection Association (NFPA) in several publications and have been incorporated into governing OSHA regulations. Most important, reference guidelines can be found in:

- NFPA Bulletin 33;
- OSHA Section 1910.107; and
- NFPA Industrial Fire Hazards Handbook, Chapter 25.

Here are some highlights from these references.

First, equipment should be listed and approved by nationally recognized approval agencies, such as Underwriter Laboratories Inc. (UL), Factory

Mutual Engineering Corp. (FM), Edison Test Labs (ETL) and others in the United States. In Canada, certification by the Canadian Standards Association (CSA) is required. Approved status of the equipment means the equipment has been tested and evaluated by a nationally recognized approval agency and has met the established standards of safety.

Spray operations must be confined to properly designed spray booth, spray rooms, or designated spray area.

All spray areas should be provided with mechanical ventilation adequate to transplant flammable or combustible dusts, vapors, mists, residues, or deposits to a safe location. Ventilation for spray booth should be adequate to confine air suspended powder to the booth and recovery system at all times. Average air velocity through electrostatic booth openings shall not be less than 60 ft. (18.2m) per minute (however, many sources say the velocity should be at least 90 ft. (27.7m) per minute).

Parts being coated should be supported on conveyors or hangers properly connected to ground, with a resistance of 1 megohm or less.

All electrically conductive objects in the spray area, except those objects required by the process to be at high voltage, should be adequately grounded.

Spray areas must be protected with an approved automatic fire extinguishing system.

Fixed powder application equipment should be protected further by approved flame detection apparatus that will, in the event of ignition, react to the presence of a flame within one-half second and:

- Shut down all energy supplies (electrical and compressed air) to conveyor, ventilation, application, transfer, and powder-collection equipment;

Chapter 7

- Close segregation dampers in associated ductwork to interrupt airflows from application equipment to powder collectors; and
- Activate an alarm.

These highlighted guidelines are obviously directed more toward the safe operation of a powder coating system than toward a productive operation. However, as stated before, the safest operations are also generally the most productive operating powder spray systems.

CHAPTER 8

HEATING APPLICATION

Heating operations are required for a variety of purposes on a powder coating line. These are usually accomplished with ovens of various forms, selected according to the needs of a particular operation. They can heat parts, such as porous castings, to rid them of occluded gas; burn accumulated material from part supports in a cleaning step; raise the temperature of previously cleaned parts to prepare them to accept powders, as in the fluidized bed process; and reheat coated and cooled parts to promote further flow of the applied material. Also, heating can remove water remaining from prior operations that would cause trouble if carried to the powder coating station. Most important, heating is used to melt, flow, and cure powdered materials applied at room temperature by electrostatic spray processes.

Since powder coating operations are usually conducted at high speed under a production environment, heating functions must be carried out in the most efficient and cost-effective manner. Requirements of a particular application must be thoroughly studied and matched with the capabilities and design principles of available ovens. Thoroughly investigating all aspects of the heating components of a powder finishing line is critical to achieving an efficient, effective, and satisfactory operation that will produce a high-quality product.

PREHEATING

Parts on their way to the coating application are preheated when it is necessary to “dry off” any moisture remaining from previous cleaning or conditioning steps. Such heating must be only adequate enough to accomplish this simple

function. Temperatures—at most—can be in the range of 190°F (88°C) and can be attained with any number of available ovens. Ventilating the area is of little significance. Water vapor must be removed to allow the time-dryness relationship.

Also, preheating is needed to raise the temperature of parts to be coated by processes that “fuse” the powder on the part. This requires the establishment of a temperature-time coating cycle so coating thickness can be reproduced. The hotter the part, the more the amount of material adheres before the temperature falls below the fusion point. Heat can reduce the Faraday Cage effect by allowing penetration into crevices hard to penetrate otherwise. The temperature-time curve for such ovens must be known and reproducible. Generally, such ovens need not be ventilated beyond required safety considerations. These conditions can be met easily by any number of commercial ovens.

POSTHEATING

Postheating operations on a powder finishing line are perhaps the most critical. They are used to melt, flow, and cure the powder applied to the part at ambient temperature, as with the electrostatic spraying process. This application of heat has to be very carefully controlled because temperature-fluidity characteristics of a particular powder are peculiar to that powder. It is this relationship that determines how the flow of the material will take place as the temperature is raised. Most materials cross link and become more viscous with time at a given temperature. For thermosetting materials, this process further complicates the control.

Chapter 8

Final properties of the coating can be acquired only uniformly over the part if all areas of the coating are treated in thermally equivalent conditions. For this reason, the postheat ovens again must be of high quality and equipped with adequate controls to ensure reproducibility.

PROCESS CONSIDERATIONS

Many elements are variables that must be considered and studied when selecting ovens for the powder coating line. Of utmost importance are:

- Product: size, configuration, mass, temperature limitations.
- Conveyor: method, product holder, line speeds.
- Powder: formulation type, thickness, cure profile, color, gloss, test for cure.

All parameters should be defined and communicated to equipment and powder suppliers involved to ensure an integrated system and successful installation.

AVAILABLE METHODS OF HEATING

Several individual methods and combinations of heating techniques have been successfully used to cure various powder coatings in a wide range of applications. New technology in curing ovens and powder coatings have allowed dramatic improvements in cure results in the last few years.

Hot Air, Gas, or Electric Convection

Convection heating uses air as a medium to transfer heat from the energy source to the product. Many convection systems use a fuel source (gas, oil, or steam) that provides heated air circulation in the oven chamber. Using a combustion chamber, the oven atmosphere can contain combustion products, solvent vapors, and possibly traces of unburned fuel. Other convection

ovens utilize electric low-intensity infrared elements (calrods, resistance emitters) to provide a clean, safe method of convection heating.

The time required to bring powder deposited on the part to its cure temperature largely depends on the mass of the part and the rate at which the part accepts heat using convection heating. Large metal objects may require 30 minutes or more to reach the desired cure temperature. Smaller parts can be brought to temperature much more rapidly—6 to 8 minutes. This heat absorption by the part, other than the surface, is a waste of heat energy as far as powder curing is concerned. But considering process requirements, such as part configuration, products with varying size and dimension and processes, where products of similar configuration cannot be batched, this may be the most flexible and efficient method of curing.

Temperature response time of large convection ovens is not particularly rapid, often taking an hour or more to reach operating temperature from a cold start. Convection ovens require consideration of floor space and routine cleaning if good finishes at high production rates are to be obtained. Despite these limitations, convection ovens are currently the most popular for industrial painting and curing. Energy and operating costs, however, are often high, and users should be aware of alternative methods for their production lines.

Infrared Radiation

Short wave, high-intensity infrared heating uses electrical energy to produce a direct, radiant method of heating. Infrared is transmitted directly from emitter to product via electromagnetic waves traveling at a speed of light (186,000 miles/second). Unlike convection heating, high intensity infrared requires no medium for heat transfer. Radiation is a line-of-sight method; it only cures what it sees. Heated energy is transferred quickly, cleanly, and efficiently, typically with tungsten quartz infrared lamps. Short-wave heaters also penetrate the substrate. High intensity infrared can have fast temperature-time response.

Curing ovens using this method of radiation heating are compact in size and can be zoned to match exact product configuration and size. Oven start-up times of 10 to 15 minutes are common. Savings in energy, space, and time can be realized with high-intensity infrared if the part configuration is correct for infrared heating.

Infrared radiation is best used with products of consistent shape, produced on dedicated lines with large volume. A direct line of sight—heater to object surface—is needed for proper powder cure, and cure is affected by object distance. Rotating the coated product during the infrared cure for round or cylindrical shape product provides uniform heating with consistent cure results. Reflow and cure times range from 10 seconds to 120 seconds, using high intensity infrared.

OVEN CAVITY ATMOSPHERE

Oven cavity atmosphere is critical to both safety and product appearance. Solvent or vapor concentration must be kept to not more than 25% of the lower explosion limit (L.E.L.). Thus, a specific amount of oven air may be exhausted and replaced on a continuous basis during operation. Fresh input air should be introduced to the oven for solvent or vapor dilution, and then exhausted. In powder applications, the amount of solvent released is near zero. Volatiles may consist of low-molecular weight resins, water, blocking agents, etc., but usually no solvents. Exhausted air

in all powder curing applications is routed outside the building. Powders contain no hazardous solvents. The exhaust and supply air systems are arranged to provide a slightly negative pressure within the oven. Large convection ovens are often located near factory roofs because of the heat loss and flow to the work area around the oven. High-intensity infrared systems do not provide a heated area around the oven, however. Ovens must be sized to permit adequate cure of the powder and air flow.

Oven cavity wall construction is often steel or ceramic. Walls are typically assembled from modules and are insulated to contain heat within the oven.

SAFETY

The exhaust fan is a primary oven safety feature. It removes solvents and combustion vapors to avoid explosion hazard. Powder vapors must be removed to keep the color from discoloring from the materials that come off the powder during the curing process. Exhaust and recirculation fans must be equipped with air flow sensors. These devices will monitor serious disruptions in air flow, and shut down the oven if any are detected.

Manufacturing safety provisions and regulatory requirements should be followed for safe operation. All oven safety features should be checked on a quarterly basis.

CHAPTER 9

POWDER STORAGE AND HANDLING

Powder, like any coating material must be shipped, inventoried, and handled in its journey from the powder coating manufacturer to the point of application. Manufacturers' recommendations, procedures, and cautions should be followed. Although various powders may have specific requirements, some universal rules apply. It is important that powders should always be:

- Protected from excess heat;
- Protected from humidity and water; and
- Protected from contamination with foreign materials, such as other powders, dust, dirt, etc.

These are so important, they deserve more elaborate explanations.

Excess Heat

Powders must maintain their particle size to allow handling and application. Most thermosetting powders are formulated to withstand a certain amount of exposure to heat in transit and in storage. This will vary according to types and formulation, but can be estimated at 100-120°F (38-49°C) for short-term exposure. When these critical temperatures are exceeded for any length of time, one or all of the following physical changes may happen. The powder can sinter, pack, and/or clump in the container. Pressure of powder weighing on itself (i.e., large tall containers) can accelerate packing and clumping of the powder toward the bottom of the container.

Manufacturers recommend long-term storage temperatures of 80°F (27°C) or lower.

Unless its exposure to heat has been excessive over an extended period of time, powder that has experienced such changes can usually be broken up and rejuvenated after being passed through a screening device.

Powders with very fast or low-temperature curing mechanisms may undergo a chemical change as a result of exposure to excess heat. These powders may partially react or "B stage." Even though these powders may be broken up, they will not produce the same flow and appearance characteristics as unexposed powders. They will have, and irreversibly retain, restricted flow, even to the point of a dry texture.

Powders formulated with chemical blocking agents to prevent curing below certain trigger temperatures do not typically "B stage" at temperatures below 200°F (93°C).

Protect from Humidity and Water

Water and powder do not mix when the intent is to spray as a dry powder. Exposure to excessive humidity can cause the powder to absorb either surface or bulk moisture. This causes poor handling, such as poor fluidization or poor gun feeding, which can lead to gun spitting and eventually feed hose blockage. High moisture content will certainly cause erratic electrostatic

Chapter 9

behavior, which can result in changed or reduced transfer efficiency and, in extreme conditions, affect the appearance and performance of the baked coating film.

Contamination

Because powder coating is a dry coating process, contamination by dust or other powders cannot be removed by filtering, as in liquid paint. It is imperative, therefore, that all containers are closed and protected from plant grinding dusts, aerosol sprays, etc.

STORAGE RECOMMENDATIONS

Storage stability properties of powder coatings need not cause problems at the end user's facility, provided that a few simple precautions are taken. Among these precautions are:

1. Control temperature, 80°F (27°C) or less. Remember that powder requires minimal storage space. For example, a semi-tractor-trailer-sized area can accommodate 40,000 lbs. (18,143 kg) of powder, which is approximately equal to 15,000 gallons (56,775L) of liquid paint at applications solids.
2. Efficiently rotate the stored powder to minimize inventory time. Powder should never be stored for a period exceeding the manufacturer's recommendation.
3. Avoid having open packages of powder on the shop floor to preclude possible moisture absorption and contamination.
4. Precondition powder prior to spray application by providing preconditioning fluidization, as is available on some automatic systems, or by adding virgin powder through reclaim system. These techniques will break up the powder if minor agglomeration has occurred in the package.

5. Maximize powder transfer efficiency in the booth to avoid problems associated with recycling large quantities of powder.

6. Minimize the amount of powder coating material held on the shop floor if temperature and humidity of application areas are not controlled.

SAFETY

Powder coatings contain polymers, curing agents, pigments, and fillers that require safe operator handling procedures and conditions. Pigments may contain heavy metals, such as lead, mercury, cadmium, and chromium. The handling of materials containing such elements is controlled by OSHA regulations. End use may be restricted according to Consumer Product Safety Commission Regulations.

Under some circumstances, OSHA regulations require the applicator to inform employees of the hazards associated with handling certain components or powder coatings. The applicator is advised to obtain this information from the supplier in the form of a Material Safety Data Sheet. Powder coatings should be handled in a manner as to minimize both skin contact and respiratory exposure consistent with particular Material Safety Data Sheet recommendations. Obvious health reactions attributed to any powder coating operation should be referred to a physician as soon as possible.

Opening, emptying, and handling powder containers, such as boxes and bags, often present the greatest worker exposure, even with well-designed systems. Engineering practices, personal protective equipment, and good personal hygiene should be used to limit exposure. In a well-designed spray operation, there should be negligible exposure of employees to dust. Powder coatings, because of their fine particle size and frequently large percentage of TiO₂, will absorb moisture and oil readily.

Powder Storage and Handling

If powder is left in contact with the skin for extended periods, it tends to dry out the skin. To prevent this, gloves and clean clothing should be worn by the workers. Operators of manual electrostatic guns must be grounded. To prevent carrying powder away from work, workers should change clothes prior to leaving the workplace. If powder does get on the skin, it should be washed off at the earliest convenient time, at least by the

end of the day. Workers who show skin reactions on exposure to powder must be especially careful to wash frequently. Washing the skin with organic solvents is an unsafe practice that should be forbidden. Generally, cleansing with soap and water is the appropriate hygienic practice. Additional information should be obtained from the supplier's Material Safety Data Sheet.

CHAPTER 10

REPAIR OF PARTS AND HANGER STRIPPING

The methods of part repair after powder coating can be put into two categories—touch-up and recoat.

Touch-up repair is appropriate when a small area of the coated part is not covered and is unable to meet finishing specifications. When hanger marks are not acceptable, touch-up is required. Touch-up also may be used to repair slight damage from handling, machining, or welding during assembly.

Recoat is required when a part is rejected because of a large surface area defect or when touch-up is not acceptable. At this point, there is a variety of options that should be considered carefully. Usually the rejected part can be repaired with a second coat. Another option is stripping and repainting the part. Stripping can also clean part hangers to provide a good ground for electrostatic spray.

TOUCH-UP

Liquid touch-up paint is applied with a small brush, aerosol spray, or airless gun. The paint is air-dried. The drying process can be accelerated with a low-temperature bake. Touch-up paint is used after the powder coating has been fully cured in a bake oven. Hanger marks, light spots in corners and seams, damage from welding or assembly, and other small defects can be touched up. Generally, a color-matched acrylic enamel or lacquer is used. Touch-up paint cannot be used if it will not meet the performance specifications required during the expected life of that part.

Touch-up should not be used to repair a faulty finish unless the resulting product meets inspection standards.

RECOAT

Applying a second coat of powder is the common approach to repair and reclaim rejected parts. However, the defect should be carefully analyzed and the source corrected before recoating. Do not recoat if the reject is caused from a fabrication defect, poor quality substrate, poor cleaning or pretreatment, or when the thickness of two coats together will be out of tolerance. Also, if the part is rejected due to undercure, it merely needs to be rebaked at the required schedule.

A second coat is effective to cover light areas, surface defects from dirt and contamination, rough spots from heavy film build or gun spitting, and color change from severe overbake. Rough surfaces and protrusions should be sanded smooth before recoating.

Parts inspected on-line can be left on the conveyor to receive a second coat. These parts can pass through the pretreatment stages with raw parts. If the recoated parts show water spots or stains, an adjustment can be made in the final rinse stage. Chemical suppliers can offer recommendations. When parts for recoat are hung together, cleaning and pretreatment is not necessary. However, if the rejected parts have been stored to accumulate a practical number, they should be checked for dirt and contamination.

Chapter 10

Coat Entire Part

When applying the second coat, normal mil thickness should be applied to the entire part. A common mistake is to coat only the defect area. This leaves a rough gritty surface where there is only a very thin overspray layer on the remainder of the part. The same recommended cure schedule is used for the second coat.

Intercoat adhesion can be checked after recoating on selected samples by using the cross hatch test or simply scratching the surface to see if the second coat peels easily from the first. Some powder coatings may need to be lightly sanded to provide a good anchor for the second coat.

REBAKE

When a part is undercured during the first coat, it can be repaired by just returning it to the bake oven for normal cure schedule at the specified time and temperature. Properties will be recovered when the part is properly cured, with some exceptions, such as certain chemically controlled low-gloss coatings. Partial cure will result in a higher gloss, which does not drop to the same level during final cure that would have been obtained with an adequate initial cure.

STRIPPING

Stripping is usually the last alternative for part repair since stripping rejected product can add greatly to production cost and disrupt the production line flow. Stripping coated parts becomes necessary, however, when the reject is caused by poor pretreatment or when touch-up or two coats are not acceptable.

On the other hand, stripping plays an important role in effectiveness of the powder coating line by providing clean hangers for a good electrical ground. Hangers should be stripped periodically. Stripping methods are discussed in the following paragraphs. (Note: There is a difference of opinion that chemical stripping is the preferred method.)

Chemical strippers are available to be used hot (raised temperature) or cold (ambient) in a dip tank. There are acid, alkaline, and molten salt types, with selection depending on the type of parts and hangers and the coating to be removed. The main advantage of chemical strippers is the low initial capital investment for equipment. Disadvantages include safety hazards of handling the chemicals, high costs of chemical replacement and disposal, and chemicals laden with paint. Some parts, such as aluminum alloys, may not be able to withstand corrosion of the chemicals.

Burn off

Burn off, or pyrolysis, ovens for stripping use high temperatures to incinerate the coating. They can be batch type or on-line ovens that operate at about 800°F (427°C), with the pollution control exhaust operating at temperatures of approximately 1200-1300°F (649-704°C). Burn-off ovens eliminate pollution and disposal problems. They are relatively efficient to operate, but require large capital investment and need some type of post cleaning to remove residual ash. The parts must withstand 800°F (427°C) temperatures. Some coating chemistries are not suitable for this stripping technique. Consult the equipment manufacturer and local regulatory agencies. It should also be noted that repeated stripping of tooling may require some type of alloy to prevent breaking or deforming.

Shot Blasting

Shot blasting, or abrading, can be used to strip parts or hangers when other methods have been ruled out. This process is very slow due to toughness of the cured powder coating. The disadvantage of this process is that it erodes (thins) the tooling and exposes more surface area, which becomes harder to strip when recoated.

Cryogenic

Cryogenic stripping embrittles the film with liquid nitrogen, then uses a nonabrasive shot blast to easily remove the coating. This is a fast, nonpolluting method, but it requires specialized

Repair of Parts and Hanger Stripping

equipment. Parts must endure -100°F (-37°C) temperatures, and some type of alloy may have to be considered for tooling.

GENERAL

Consideration must be given as to whether or not parts can withstand any of the methods

described. Chemical and equipment suppliers can assist in that determination.

When it comes to tooling, proper design can reduce the amount of cleaning necessary. An inexpensive part hook can become very costly if it must be replaced frequently.

CHAPTER 11

QUALITY CONTROL

Quality control in the finishing industry requires attention to more than just coating. In fact, the majority of problems occur for reasons other than coating faults. To assure quality where coating may be a factor, statistical process control (SPC) can be a useful tool.

SPC

SPC involves measuring the powder coating process using statistical methods and improving it to reduce variation at desired process levels. SPC can also help determine the difference between typical variation inherent in the process and special causes of variation that can be detected and eliminated.

A good initial step is to create a process flow diagram of the system. Be sure to go out on the shop floor and observe how the process is actually performed instead of relying totally on how supervisors and process engineers think it performs.

Reading the key control characteristics (KCCs) at each step of the process can then be derived from the flow chart. These key control characteristics are variables that are most important and can be monitored using SPC charts.

A typical list of key variables to monitor may include:

- Dry film;
- Oven cure;
- Powder flow rate of virgin and reclaim;
- Particle size;
- Atomizing air; and
- Transfer efficiency.

Since SPC is a data-driven, analytical process, the numbers themselves must be reliable, with as little variation as possible. The more variance in a reading, the wider the SPC control chart limits are for that variable and the less sensitive it becomes to changes in the process.

Formal experiments reveal the capability of your measurement system for the parameter of interest. These include tests such as gage R&R studies and short term machine capability studies. Readily available is literature on how these studies are performed.

A quality assurance/quality control system using SPC enables the powder coating user to be proactive in preventing defects. It allows decisions to be based upon data rather than on subjective opinions. By using SPC to monitor and improve critical components in the coating process, the quality of the final product will consistently improve, lowering total cost.

AVOIDING AND CORRECTING QUALITY VARIATIONS

Close attention to a few critical areas will avoid, or at least minimize, a multitude of quality variations with a powder finishing system. Careful attention should be given to having a clean, dry, compressed air supply, clean-sieved reclaim powder, good ground to parts and equipment, humidity-controlled spray booth air, and regular inspection and replacement of wear parts. The powder coating equipment should be installed and operated as recommended by the equipment supplier's manual. Follow the recommendations on your powder coating material data

Chapter 11

sheets. Have a good preventive maintenance program and stringent housekeeping practices.

The following figures provide information on how to avoid specific variations to quality and how to correct them if they occur.

The first five figures assist the reader in surface preparation requirements. Figure 11-1 presents a summary of various application methods. Figure 11-2 is a troubleshooting guide for iron phosphatizing and Figure 11-3 is a similar guide for zinc phosphatizing. Figure 11-4 presents a troubleshooting information for the chromium phosphate processing solutions. Figure 11-5 focuses on the black oxide coating process.

Figure 11-6 discusses fluidize bed operations, presenting four problems and their various solutions. Figure 11-7 discusses hoses and pump venturi operation. Two problems are discussed in this figure. Figure 11-8 features overall electro-

static coating and presents possible solutions for six problems.

Figure 11-9 deals with collection and reclamation operation. Two problems are discussed. Coating finish-cured film physical properties are discussed in Figure 11-10 and five problems are presented. Figure 11-11 relates eight problems associated with coating finish, cured film appearance.

Figure 11-12 explores the problems associated with poor output of powder. Three problems are presented. Figure 11-13 relates problems associated with poor or insufficient coverage. Figure 11-14 presents five problems associated with the disturbance in cured film. This chapter's final figure, Figure 11-15, presents, in graphic form, suggested temperature and humidity parameters for applying organic powder coatings.

ADVANTAGES	DISADVANTAGES
<p><i>BRUSH-ON/WIPE-ON:</i></p> <ul style="list-style-type: none"> • No capital investment. • Can handle very large or heavy parts. • Parts do not have to be moved. • Can be started/stopped quickly. • Good for intermittent work schedules. 	<ul style="list-style-type: none"> • Labor intensive. • Low production rate.
<p><i>STEAM GUN:</i></p> <ul style="list-style-type: none"> • Low capital investment. • Can handle large or heavy parts. • Parts do not have to be moved. • Can be started/stopped quickly. • Good for intermittent work. 	<ul style="list-style-type: none"> • Labor intensive. • Low production rate.
<p><i>IMMERSION:</i></p> <ul style="list-style-type: none"> • Can be automated. • Moderate production rate. 	<ul style="list-style-type: none"> • Moderate capital investment. • Must be able to lift parts. • Requires start-up time.
<p><i>POWER SPRAY WASHER:</i></p> <ul style="list-style-type: none"> • Normally automated. • High production rate. 	<ul style="list-style-type: none"> • Higher capital investment. • Requires start-up time.

Figure 11-1. Summary of the various application methods.

Chapter 11

PROBLEM	CAUSE	REMEDY
Poor Coating.	pH not in range. See "Poor Cleaning."	Adjust pH down with acid, up with caustic.
Poor Cleaning.	Temperatures too low. Concentration too low.	Raise temperature. Increase concentration.
Spotty Coating/ Streaking.	Poor exposure to cleaner.	Check racking. Check nozzles. Check pressure, 15-25 psi.
	Contaminated rinses. Poor cleaning.	Check rinse tanks. See "Poor Cleaning."
Rusting.	Contaminated rinses. Poor exposure.	Check rinse tanks. Check racking. Check nozzles.
	Coating weight too low.	Raise temperatures. Lengthen time. Increase concentration.
	Dry-off too slow. Drying between stages.	Increase temperature in final rinse. Run at lower temps. Better placement of nozzles. Use fog nozzles.
Solutions Foaming.	Temperature too low. Pressure too high.	Raise temperature. Check for plugged nozzles.
	Pump picking up air.	Check pump packing. Check water level.
Poor Paint Adhesion.	Coating too heavy.	Lower temperature. Lower concentration.
	Poor cleaning. Contamination.	See "Poor Cleaning." Look for source of silicone near washer.
	Bad steel	Check raw material for excessive soil.

Figure 11-2. A troubleshooting guide to iron phosphatizing.

PROBLEM	CAUSE	REMEDY
Coating weight too low.	Phosphate or accelerator concentration too low. Temperature too low. Process time too low.	Increase concentration. Raise temperature. Lengthen time.
Coating weight too high.	Phosphate or accelerator concentration too high. Process time too long.	Decrease concentration. Shorten time.
Powder on coating.	Poor rinses. Excessive sludge. Accelerator concentration too high.	Keep rinse overflowing. De-sludge tank. Allow concentration to drop
Spotty coating.	Poor cleaning. Low concentration of phosphatizer or accelerator. Poor solution coverage. Resistant metal.	Check cleaning tank. Increase concentration. Check racking and nozzles. Add Jernstedt salts to rinse or to cleaner tank.
Rusting.	Coating weight too low. Final dry-off too slow. Dry-off between stages.	See "Problem—Coating weight too low." Increase temperature in the final rinse—use air blow-off. Better placement of nozzles. Use fog nozzles. Run at lower temps.
Streaking.	Poor cleaning. Poor rinsing. Dry-off between stages.	Check cleaning stage. Keep rinses overflowing. Better arrangement of nozzles. Use fog nozzles. Run at lower temps.

Figure 11-3. A troubleshooting guide for zinc phosphatizing.

Chapter 11

PROBLEM	CAUSE	REMEDY
Bath pickles metal and creates dusty coating.	Accelerator level too high.	Reduce accelerator level by processing aluminum or autodraining* and adjusting the bath.
Low coating weight.	Aluminum concentration too high in bath. Accelerator too low. Concentration too low. Total acid too high in relation to chromium concentration.	Autodrain* and adjust. Add accelerator. Add make-up chemical. Autodrain* bath and adjust.
No coating.	Total absence of accelerator in bath.	Add accelerator.
Sludge plugging nozzles	Aluminum concentration in bath too high. Alkaline salts dragged into bath.	Autodrain* bath and adjust. Increase overflow rate of rinse following cleaner.
*Autodraining is a technique whereby the solution is simultaneously being drained and replenished with fresh water and make-up chemical.		

Figure 11-4 . Chromium phosphate processing solution troubleshooting guide.

PROBLEM	CAUSE	REMEDY
Red, rusty coating on mild steel.	Temperature too low. Concentration of bath too high for the type of steel. Iron contamination in bath.	Increase heat to cause solution to boil. Dilute bath so it boils at a lower temperature. Add proprietary chelating agent at a rate of 1-6 lb./100 gal. (.5-2.7 kg/378.5 L).
Red, rusty coating on high speed or hard steels.	Concentration of bath too high for this type of steel.	Dilute bath to boil at 255-275°F (123.9°C) and run for 30-45 minutes.
Red, rusty coatings on iron castings.	Concentration of bath too high for this metal.	Dilute to boil at 255-275°F (123.9°C) run for 45-60 minutes.
No coating on high nickel and/or chromium steels.	If these steels will coat at all, it will generally be at high temperatures.	Increase concentration of bath to boil at 300-320°F (148.9-160°C).
No coating formed on mild steel.	Thin, invisible oxide film on metal surface. Iron contamination in bath. Iron and/or carbon contamination.	Run metal through muriatic pickle. Add proprietary chelating agent. Add proprietary chelating agent or freeze out carbonated by dropping temperature under 200°F (93°C).
White, streaky deposits on parts when dried.	Excessively contaminated rinse.	Dump, rinse, and refill. Maintain good overflow.

Figure 11-5. A troubleshooting guide to the black oxide coating process.

Chapter 11

PROBLEM	CAUSE	REMEDY
Dusting—powder blowing out of hopper.	Air pressure too high. Powder too fine.	Adjust air regulator to lower pressure to fluid bed. Too much reclaim added to virgin powder. Virgin powder pulverized too fine by manufacturer.
No air—percolating through powder surface.	Insufficient air pressure. Plugged membrane. Obstructed membrane. Compacted powder.	Check air supply, increase air regulator pressure. Check air line size to equipment.* Check membrane for plugged pores from dirty air supply. Check bottom of bed for plastic, cardboard, or other large obstructions. Manually loosen powder and fluidize well with clean, dry air.
Rat holing—air blowing large jet holes through powder surface.	Powder level too low. Packed or moist powder. Obstructed membrane. Plugged or broken membrane.	Add powder until hopper is 2/3 full when fluidized. Manually loosen powder and fluidize well with clean, dry air. Check compressed air and booth air for high humidity. Check bottom of bed for plastics, cardboard, or other large obstructions. Check membrane for plugged pores from dirty air supply, cracks, or holes.
Stratification—powder separating into layers of fine and coarse particles.	Powder level too high. Powder too fine.	Remove powder until 2/3 full when fluidized. Too much reclaim added to virgin powder. Virgin powder pulverized too fine by manufacturer.
* Follow equipment manual instructions and specifications.		

Figure 11-6. Fluidized bed operation.

PROBLEM	CAUSE	REMEDY
Plugged from impact fusion— hard build-up.	Normal build-up.	Clean or replace parts.
	Air pressure too high. Moisture in air supply. Composition of powder feed hoses. Worn venturis and wear parts. Powder too fine.	Turn down air settings on pumps and guns. Check air supply for clean, dry air. Check hoses. Replace worn parts.* Too much reclaim added to virgin powder Virgin powder pulverized too fine by manufacturer.
Insufficient powder feed.	Powder type or formula.	Some resin types tend to have more impact fusion. Check with your powder supplier.
	Powder not fluidizing. Obstruction from contaminated powder supply. Kinked or flattened hoses. Worn pump venturis. Low air pressure.	See fluidized bed section. Clean out venturis and hoses.* Check powder supply for contamination. Sieve all reclaim before using. Replace if permanently deformed. Avoid sharp bends. Use hose saddles for reciprocators. Run hoses in covered trench across traffic aisles. Replace worn parts.* Check air supply. Adjust all settings to pumps and guns.

*Follow equipment manual instructions and specifications.

Figure 11-7. Hoses and pumps—Venturi operation.

PROBLEM	CAUSE	REMEDY
<p>Poor charging—inadequate powder build or wrap on part</p>	<p>High-voltage source not providing enough KV at charging electrode or grid.</p>	<p>Check high voltage source is on. Systematically check electrical continuity from voltage source to electrode (grid)* including cable, resistors and fuses. Replace missing or broken electrode (grid). Clean electrode (grid) insulated by powder build or impact fusion.</p>
	<p>Poor ground.</p>	<p>Check ground from conveyor rail (or rub bar when used) through hanger to part. All contact areas must be free of powder build, heavy grease and other insulating material.</p>
	<p>Powder delivery (feed) is too high.</p>	<p>Turn down powder feed until all material passing through charging corona (field) is adequately charged.</p>
	<p>Excessive moisture in powder booth air.</p>	<p>Moisture in humid air will tend to dissipate humidity in the powder spray area.</p>
	<p>Powder too fine.</p>	<p>Too much reclaim added to virgin powder. Virgin powder pulverized too fine by manufacturer.</p>
	<p>Powder type or formula.</p>	<p>Some resin types charge better than others and some formulas are designed for thin film application. Check with your powder supplier.</p>
	<p>Powder delivery air too high. Powder blowing by part.</p>	<p>Turn down air setting or move gun position farther away from part.</p>
<p>*Follow equipment manual instructions and specifications.</p>		

Figure 11-8. Overall electrostatic coating operation.

PROBLEM	CAUSE	REMEDY
<p>Poor penetration—powder will not coat Faraday Cage areas (holes, grooves, channels, inside corners, and recesses).</p>	Powder delivery too low.	Turn up powder delivery air setting.
	<p>Poor ground. Powder spray pattern too wide.</p>	<p>Use gun barrel extension. Check ground. Select smaller deflector or use suitable slotted barrel and cover. (Consult your equipment supplier.)</p>
	Voltage too high.	<p>Turn voltage setting down so powder builds on part edges and leading surfaces do not repel powder from corner.</p>
	<p>Powder delivery velocity too high.</p>	<p>Turn air settings down so powder/air stream does not blow powder out of corners.</p>
	Poor gun placement.	<p>Adjust gun position so powder cloud has a direct path to recess area.</p>
	Powder too fine.	<p>Too much reclaim added to virgin powder. Virgin powder pulverized too fine by manufacturer.</p>
<p>Back charging—powder layers are repelled from part in spots.</p>	<p>Voltage too high. Gun positioned too close to part.</p>	<p>Turn down voltage setting. Change gun placement away from part.</p>
	<p>Poor ground. Powder too fine.</p>	<p>Check ground. Too much reclaim added to virgin powder. Virgin powder pulverized too fine by manufacturer.</p>
	Powder booth air too dry.	<p>Adjust powder spray area humidity. See chart for optimum conditions.</p>
	<p>Poor delivery and/or reclaim usually through equipment ground.</p>	<p>Provide ground for all equipment*</p>
<p>Powder picks up a random charge through powder or in fluid path. Reverse charging usually through reclaim system.</p>	Powder booth air too dry.	<p>Adjust powder spray area humidity. See chart for optimum conditions.</p>
	<p>Poor delivery and/or reclaim usually through equipment ground.</p>	<p>Provide ground for all equipment*</p>
<p>*Follow equipment manual instructions and specifications.</p>		

Figure 11-8. Continued.

Chapter 11

PROBLEM	CAUSE	REMEDY
Powder feed spurting or slugging—interrupted powder feed.	Insufficient air pressure or volume.	Check air supply. Air supply piping to equipment is large enough. Enough air volume when other equipment such as reverse air cleaning in reclaim housing pulses, air pressure to powder feed does not drop.* Check powder feed hoses.
	Hoses kinked, flattened, or too long. Hoses, pump venturis, or guns clogged with powder.	Clean hoses, venturis, and guns.* Check air supply for moisture that causes powder compaction. Check powder free flowing properties. Check spray booth air humidity. Check powder supply for contamination. Check reclaim sieve.
Poor spray pattern—not a symmetrical powder cloud (not applicable when using special deflectors for desired effect).	Worn E/S gun parts.	Replace worn feed tubes, orifices, deflectors, and covers.*
	Impact fusion build. Delivery (feed) air too low.	Clean gun parts as needed.* Check air supply. Increase air for powder feed.
	Hoses, venturis, or gun blocked with powder.	Clean hoses, venturis, and guns.*
*Follow equipment manual instructions and specifications.		

Figure 11-8. Continued.

PROBLEM	CAUSE	REMEDY
Contamination in reclaim powder.	Reclaim in-line sieve torn, missing or inoperable. Powder or dirt falling in spray booth from conveyor or hangers.	Replace sieve or repair as necessary. Clean conveyor regularly (or continuously) before entering powder spray booth. Strip hangers as needed.
	Contamination from parts entering spray booth.	Check cleaning and pretreatment equipment and ensure proper part drainage before entering spray booth.
	Contamination from plant air circulated through spray booth.	Isolate spray booth area. Preferably enclose in a room with filtered, humidity controlled air.
Spray booth dusting inadequate air flow through spray booth.	Bag or cartridge filters binding.	Clean or replace bags or cartridge filters.*
	Final filters clogged.	Check spray booth air humidity. Check filter bags or cartridges for powder leakage. Repair or replace as needed.
	Too large of open area in spray booth housing.	Reduce open area. Increased opening reduces booth air velocity.*
	Powder delivery (feed) too high.	Reduce the number of spraying or the amount of powder to each gun.*
*Follow equipment manual instructions and specifications.		

Figure 11-9. Collection and reclamation operation.

Chapter 11

PROBLEM	CAUSE	REMEDY
Poor impact resistance/poor flexibility.	Under cured.	Increase oven temperature (or): Increase dwell time in oven.
	Poor cleaning or pretreatment.	Check pretreatment equipment and chemicals.
	Film thickness too high.	Reduce film thickness by adjusting application equipment.*
	Change in substrate thickness or type. Powder resin type or formula.	Check substrate with supplier. Check with powder manufacturer.
Poor adhesion.	Poor cleaning or pretreatment.	Check pretreatment equipment and chemicals.*
	Change in substrate. Under cured.	Check substrate with supplier. Increase oven temperature (or): Increase dwell time in oven.
	Powder resin type or formula.	Check with powder manufacturer.
Poor corrosion resistance.	Poor cleaning or pretreatment.	Check pretreatment equipment and chemicals.*
	Under cured.	Increase oven temperature (or): Increase dwell time in oven.
Poor chemical resistance.	Under cured.	Increase oven temperature (or): Increase dwell time in oven.
	Powder resin type or formula.	Check with powder manufacturer.
Poor pencil hardness/poor abrasion resistance.	Under cured.	Increase oven dwell time.
	Powder resin type or formula.	Check with powder manufacturer.

*Follow equipment manual instructions and specifications.

Figure 11-10. Coating finish-cured film physical properties.

PROBLEM	CAUSE	REMEDY
Poor surface flow—too much orange peel.	Film thickness too thin.	Increase film thickness by adjusting application equipment.
	Heat-up rate too slow.	Increase oven temperature (or): Modify oven baffling to increase heat rate.
	Powder resin type or formula.	Check with powder manufacturer.
Gloss too low for high gloss powder.	Incompatible powder contamination. Micro-pinholing from gassing.	Clean application equipment before changing powders. Check substrate for porosity. Check substrate for moisture. Check powder for moisture from reclaim or compressed air. Check film thickness, coating too thick.
	Powder resin type or formula.	Check with powder manufacturer.
Gloss too high for a low gloss type powder.	Under cured.	Increase temperature of oven (or): Increase dwell time in oven.
	Powder formula.	Check with powder manufacturer.
Contamination in powder.	See reclaim system: contamination, No. 1 through No. 4. Virgin powder contaminated.	Check with powder manufacturer.
Inconsistent film thickness.	Guns positioned wrong.	Check and reposition guns so spray patterns overlap slightly.
	Reciprocators not matched to line speed	Adjust line speed(or): Adjust reciprocator stroke.*
	Air flow in booth disturbing spray pattern.	Consult your equipment supplier.
	Defective spray equipment.	Go through application section check list.

*Follow equipment manual instructions and specifications.

Figure 11-11. Coating finish-cured films appearance.

Chapter 11

PROBLEM	CAUSE	REMEDY
Off color.	Improper oven exhaust. Bake time too long. Oven temperature too high. Variation in film thickness. Powder formulated.	Check exhaust vent fan(s).* Adjust line speed. Lower oven temperature. See coating appearance section inconsistent film. Check with powder manufacturer.
Pinholing and gassing through coating surface.		See coating appearance section, low gloss.
Pull-away or tearing—coating film shrinks leaving bare substrate.	Uncharged powder. Poor cleaning, metal preparation or dryoff.	See application section, poor charging. Check pretreatment equipment dryoff oven and part drainage.

*Follow equipment manual instructions and specifications.

Figure 11-11. Continued.

PROBLEM	CAUSE	REMEDY
Poor fluidizing properties in the powder hopper.	Pressure of fluidizing air too low.	Adjust (increase) pressure of fluidizing air.
	Fluidizing membrane is blocked.	Clean or replace the fluidizing membrane: see instructions of equipment supplier.
	Humidity of compressed air too high.	Install an air dryer with a corresponding oil-micro filter or another suitable drying system.
	Humidity of the powder too high.	Check storage facilities. Powder shall be stocked at room temperature in closed packing (maximum humidity 75%). Contact your powder supplier.
Blockage in venturis and hoses.	Free-flowing properties of the powder are bad.	Contact your powder supplier.
	Fusing of the powder in the venturi.	Clean or replace the venturi (see instructions of the equipment supplier). If necessary, reduce pressure of powder of transport air.
	Fusing of the powder in the hoses.	Clean the hose by bending and breaking up the fused powder; if necessary replace it.
	Fusing of the powder in the hoses.	Install an air dryer with a corresponding oil micro filter or an air dryer with a corresponding oil micro filter or another suitable drying system.
	Bad free flowing properties of the powder.	Contact your powder supplier.

Figure 11-12. Output of powder insufficient to coat parts.

Chapter 11

PROBLEM	CAUSE	REMEDY
Blockage in the gun.	Fusing in the gun or gun outlet. Blockage caused by contamination of the powder with dust of other coarse materials.	Clean the gun according to the instructions of your equipment supplier. When blocking occurs, frequently check humidity of compressed air and the free-flowing properties of the powder. Clean the gun according to the instructions of equipment supplier and determine the reason of this contamination. (Check powder pumps for possible impact fusion. Impact fusion particles which break off in the pump could be transported to the spray gun and result in blockage.)

Figure 11-12. Continued.

PROBLEM	CAUSE	REMEDY
Insufficient wrap-around.	Poor electrostatic charging of the powder.	Adjust level of electrostatic kilo voltage (increase). If not possible, check equipment and guns according to instructions of the equipment supplier. Check for broken electrodes on the spray gun. If found, replace electrodes. Check for possible frictional transport through powder hose. If evident, consult powder supplier for hose material recommendation.
	Insufficient ground contact.	Check the ground contacts using a suitable resistance measuring device. Correct and ensure sufficient earth to ground control.
	Output of powder too low. Using an unsuitable powder type.	Refer to problem A. Contact your powder supplier.
Poor penetration into corners, flanges, slots, etc.	Output of powder too low. Insufficient ground contact.	Refer to Problem A. Check the ground contacts and if necessary use a suitable measuring instrument.
	Powder cloud too wide.	Narrow powder cloud. If necessary, install a more suitable deflector or adjust air for cone adjustment.
Poor adherence of powder to part, powder falls from part easily.	Poor electrostatic charging of the powder.	Adjust level of electrostatic kilo-voltage (increase voltage); if not possible, check equipment and guns according to instructions of equipment supplier. See "Insufficient Wraparound."
	Powder output too high or the pressure for the transport air too high, which blows the powder from the object. Unsuitable particle size distribution of the powder or unsuitable powder type for the objects.	Reduce powder output and/or reduce pressure of the transport air. Contact your powder supplier.

Figure 11-13. Poor or insufficient coverage

Chapter 11

PROBLEM	CAUSE	REMEDY
Dust, precured or other coarse material.	Dust or other coarse parts on the metal surface. Dust or other coarse parts in powder. Precured material from original powder which is stocked according to the instructions.	Check pretreatment. Check powder and locate the cause of this contamination; if necessary, clean up the installation and use fresh or sieved powder.
Matting of powder surface.	Contamination with other powder (based on other raw materials).	Clean up the installation; if necessary, contact your powder supplier.
Orange-peel.	Warming up of the coated material is too slow or too fast. Powder type too fast or too coarse particle size distribution. Moisture contamination. Heat damage of the powder.	Check curing cycle and curing oven; if necessary, contact your powder supplier. Contact your powder supplier. Replace the powder. Replace the powder.
Cratering.	Contamination with other powder (based on other raw materials.) Bad pretreatment with e.g. remaining greases Contamination with incompatible materials from the spraying are as e.g. silicones.	Clean up the installation; if necessary, contact your powder supplier. Check pretreatment and if necessary, contact pretreatment supplier. Check the presence of incompatible materials; if necessary, clean up the installation and contact your powder supplier.
Pinholing.	Humidity of the powder too high. Air entrapment with casting. Gas entrapment and escaping due to chemical reaction.	Check storage facilities. Powder shall be stocked at room temperature in closed packing (maximum humidity 75%). Preheat objects over 320°F (160°C) and cool down before applications (only galvanized), or contact your powder supplier, who can advise a special developed powder. Keep coating thickness below 100 microns; if necessary, contact your powder supplier.

Figure 11-14. Disturbance in cured film.

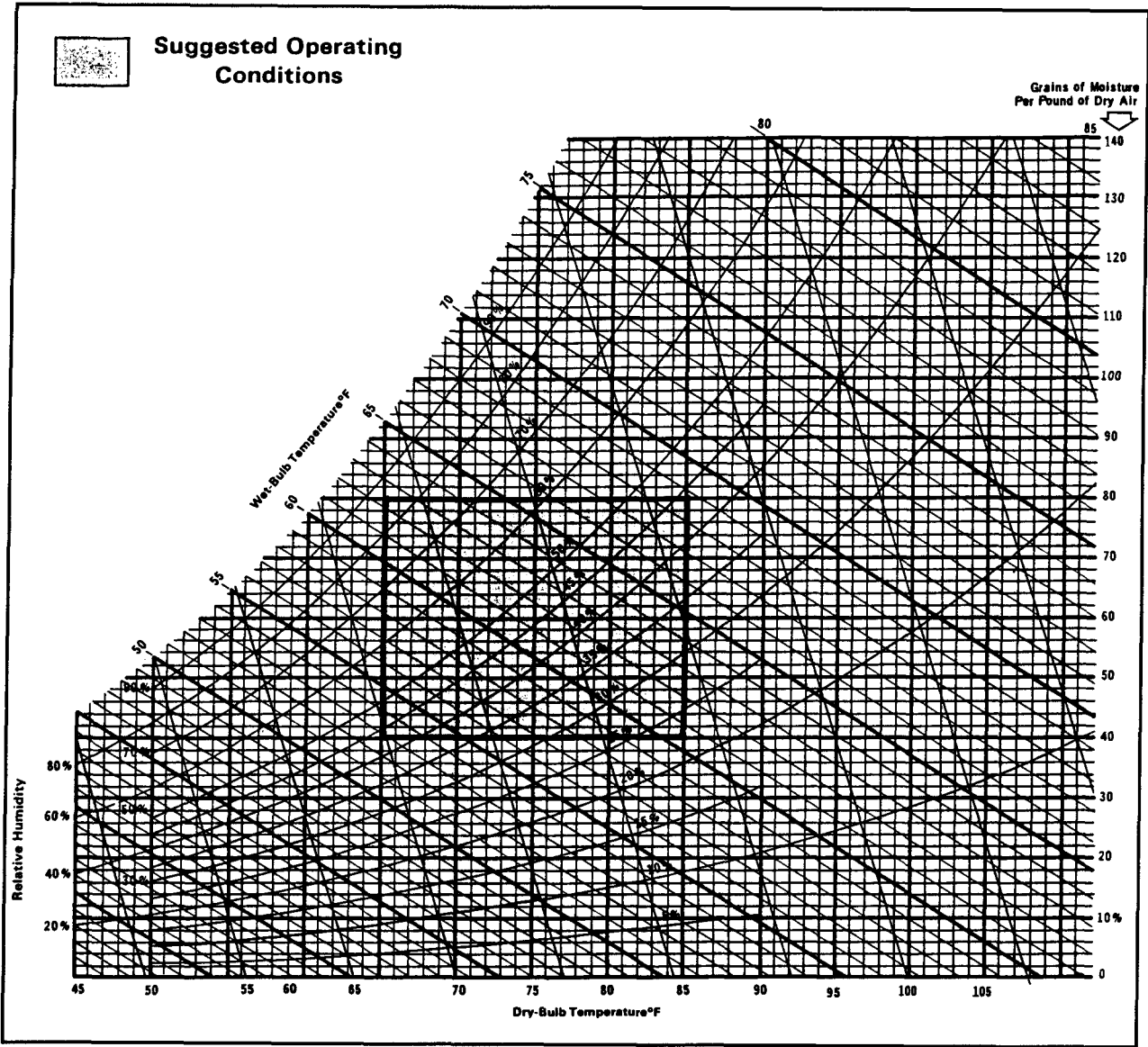

Figure 11-15. Suggested temperature and humidity parameters for the application of organic powder coatings. (Source: Ferro Corporation)



POWDER COATINGS TODAY AND TOMORROW

**By Gregory J. Bocchi
Executive Director
The Powder Coating Institute
Alexandria, VA**

Since its introduction in North America about 40 years ago, powder coating has become the fastest growing finishing technology on the market. Where it competes directly with liquid finishing, powder coating represents 15% of the finishing market and over 10% of the total industrial finishing market. More than 3,000 commercial powder coating lines in North America are now coating hundreds of products, including automobiles, appliances, sporting goods, furniture, aluminum extrusions, and various builder components. Powder has set a standard for durability and corrosion resistance difficult to match with competitive finishing systems.

In recent years, increased concerns for air and water quality, along with rising energy costs, greater consumer demand for product durability, and heightened awareness of powder and its benefits, have caused powder coating installations to grow and expand at a rate never before seen in North America. This growth and expansion have been accelerated by advances made in materials and equipment technology.

When powder coating was first used in North America in the 1950s, the powder system was limited in colors, thicknesses, exterior durability, and product application. In addition, scarcity of solid resin systems as late as the early 1970s restricted powder coating's ability to satisfy requirements for finishing many products.

Today, the manufacturers of powder coating materials and equipment have solved problems of the past, and ongoing research and technology continue to break down the few remaining barriers to powder coating. These advances have also made powder coating one of the most cost-effective finishing systems today.

Powder Coating Materials

The most significant material breakthrough has been the development of engineered resin systems designed to meet the diverse and specific needs of the metal finishing industry. Epoxy resins were used almost exclusively during the early years of thermosetting powder coating and are still in broad use today. The use of polyester resins is growing rapidly in the North American market and acrylics are a major factor in many end-users, such as the appliance and automotive industries.

Powders are available with excellent resistance to corrosion, heat, impact, and abrasion. Color selection is virtually unlimited with high and low gloss, and clear finishes available. Texture selections range from smooth surfaces to a wrinkled or matte finish. Film thickness can also be varied to suit the requirements of specific applications.

Development of resin systems resulted in an epoxy-polyester hybrid, which provides thin-layer, low-curing powder coating. Advances in polyester and acrylic resins improved exterior durability of these systems. Specific advances in resin technology include:

- Thin-layer powder coatings based on epoxy-polyester hybrids provide applications in the range of 1 to 1.2 mils for colors with good hiding power. These thin films are currently suitable for indoor applications only. Very thin films, which may require special powder grinds, can be as low as 0.5 mils.
- Low-temperature powder coatings. Powder coatings with high reactivity have been developed to cure at temperatures as low as 250°F (121°C). Such low-curing powders enable higher line speeds, increasing production capacity without sacrificing exterior durability. They also increase the number of substrates that can be powder coated, such as some plastics and wood products.
- Texture powder coatings. These coatings now range from a fine texture with low gloss and a high resistance to abrasion and scratches, to a rough texture useful for hiding the uneven surface of some substrates. These texture coatings have undergone major improvements compared to their counterparts of several years ago.
- Low-gloss powder coatings. It is now possible to reduce gloss values without diminishing the flexibility, mechanical properties, or appearance of powder coatings. Gloss values can be lowered to 1% or less in pure epoxies. The lowest gloss in weather-resistant polyester systems is about 5%.
- Metallic powder coatings are currently available in an array of colors. Many of these metallic systems are suitable for outdoor application. For excellent exterior durability, a clear powder top coat is often applied over the metallic base. Efforts have been focused on developing perfect matches for standard anodizing colors to meet the needs of the aluminum extrusion market. Another recent development is the replacement of metal flakes with non-ferrous substances like mica.
- Clear powder coatings have undergone significant improvements in the past several years with regard to flow, clarity, and weather resistance. Based on polyester and acrylic resins, these clear powders set quality standards in automotive wheels, plumbing fixtures, furniture, and hardware.
- High weatherability powder coatings. Dramatic advances have been made in developing polyester and acrylic resin systems with excellent long-term weatherability to meet the extended warranties offered by manufacturers. Also under development are fluorocarbon-based powders, which will match or exceed the weatherability of liquid fluorocarbons, with applied costs advantageous to powder.

Powder coating has also become a practical finish for products that generate significant heat levels, such as commercial lighting fixtures, and as a primer for grill tops, where it serves as a base for a liquid top coat.

Powder manufacturers continue to perfect resin and curing agent designs. Current research efforts are focused on developing and improving lower-cost, low-curing powders to help expand powder coating application to new substrates. Work continues in developing powders that are more durable with high weatherability for greater use outdoors, exhibiting higher resistance to chalking or fading in sunlight.

Powder Coating Equipment

Improvements in powder coating materials have brought advancements in application and recovery equipment technology. They are aimed at reducing the cost of powder coating systems, making the powder coating operation more efficient, and expanding to new production requirements and part configurations. Overall material efficiency of a powder coating system commonly exceeds 95%. Equipment engineers have made considerable progress in improving first-pass transfer efficiency and in better part coverage to eliminate manual touch-up from automated systems. Improved spray booth and powder delivery system designs have dramatically reduced the time and labor required for color changes. The range of equipment available today is virtually unlimited, from the single gun, manual unit to multiple gun, fully automated or robotic systems with sophisticated process controls and enormous capacity.

Other advances in application include:

- **In-mold powder coating.** An in-mold powder coating process has been developed in which powder is sprayed onto a heated mold cavity; the powder then bonds to the molding compound when the molding cycle is performed. In-mold powder coating can be applied as a primer for a liquid top coat or as a finish coat to reinforced plastics. It is also used on automotive body panels and bathtub enclosures.
- **Blank coating.** Powder coating of pre-cut metal blanks, which are then post-formed prior to final assembly, remains a strong growth area for powder. It offers high transfer efficiency, uniform film thickness, and a compact straight-line finishing operation that increases the level of automation.
- **Coil coating.** Powder coatings for coiled steel and aluminum continues to be developed, with several coil coating lines currently in operation. Wider use of powder as a coil coating will prosper as fast-curing powders, providing durable, bright, and flexible coatings, are refined and improved.

Advancements in microprocessor, robot, and infrared curing technology speed powder coating operations. These methods will continue to be adapted for more coating operations to increase their production capacities.

Comparative Economics

Today's environmental concerns are a major economic factor in the selection or operation of a finishing system. The environmental advantages of powder coating—no VOC problems and essentially no waste—can mean substantial savings in finishing costs.

As energy costs continue to rise, other advantages of powder coating become even more important. Without the need for solvent recovery, complex filtering systems are not required, and less air has to be moved, heated, or cooled, which can be a significant cost saving.

As the technology of powder coating has developed, efficiency of the process has improved. Powder is ever more competitive with liquids, delivering quality finishes that meet the requirements of a wide range of product applications.

In a study of a model coating line by the Powder Coating Institute (PCI), material costs of powder were slightly higher than a high-solids polyester finish. Yet, the bottom-line operating costs of powder — once costs of labor, maintenance, energy, clean-up and waste disposal are factored in — are significantly lower than the operating costs for other systems, by about 15% for high-solids polyester, and over 40% for conventional solvent and water-borne systems.

Its effect on workers is one cost-cutting factor that is difficult to measure. There is minimum operator training and supervision for a powder line. Employees prefer to work with dry powder rather than wet solvent-based paints because of powder's lack of fumes, reduced housekeeping problems, and minimum contamination of clothing.

Ongoing technological advancements in materials, equipment, and application techniques ensure that powder coatings will occupy an ever-increasing share of the finishing market.

INDEX

A

Abrasive blasting, 27, 28
Acid cleaners, 29, 32, 36
Acrylics, 11
Airblast, 26
Airflow, 68
Airless blast, 26
Air plenum, 48
Alkaline cleaners, 29, 31, 35
Aluminum oxide, 28
Applications, 2

B

Back ionization, 53
Batch booth, 56
Bed density, 41
Belt booth, 59
Blocked diffusion, 41
Burn-off ovens, 82

C

Calrods, 74
Capital costs, 18
Cartridge mounting arrangement, 63
Centrifugal wheel, See: airless blast
Chain-on-edge booth, 59
Chemical strippers, 82
Chromium phosphate, 34, 90
Cleaning, 25
Cleanliness, 68
Cold-rolled steel, 34
Cold water rinse, 31
Collector inlet design, 63
Combustion chamber, 74
Convection heating, 74
Corncob, 28
Cost savings, 17
Cross hatch test, 82
Cryogenic stripping, 82

D-E

Deionized water rinse, 31
Economic advantages, 18
Electrocleaning, 29, 32
Electrostatic charging medium, 42
Electrostatic coating operation, 94
Electrostatic fluidized bed
 applications, 44
 design, 46
 equipment characteristics, 45
 powder characteristics, 44
 safety considerations, 46
Electrostatic Powder Spray Coating
 ease of application, 49
 economic advantage, 48
 equipment, 49
Electrostatic spray, 39
Electrostatic spray guns, 50
Energy savings, 17
Environmental implications, 2
Epoxy
 functional, 7
 polyester hybrids, 8
 resin-based, 7
 thin-film, 7
Excess heat, 77

F

Faraday Cage, 51, 53
Feeders, 49
Finish-cured films, 99
Fluidization, 41
Fluidized beds, 39, 92
Functional Epoxy, 7

G

Gages, 68
Garnet, 27
Glycidyl acrylics, 11, 12

Index

Gravity-assisted booths, 56
Gun spitting, 77

H

Handling powder containers, 78
Hand-wiping, 29, 31, 32
Hangers, 82
Health hazards to operators, 70
Heating components, 73
Heating operations, 73
Heavy mineral sands, 27
High moisture content, 77
Horizontal coating booth, 58
Hoses and pumps, 93
Hot water rinse, 31
Housekeeping, 86
Humidity, 77
Hygiene, 78

I-L

Immersion method, 31, 32
Infrared radiation, 74
Intercoat adhesion, 82
Internal charging guns, 51
Iron phosphate, 36
Labor savings, 17
Lower explosion limit, 75

M-N

Magnetite, 27
Material Safety Data Sheet, 70, 78
Mechanical blasting, 28
Migrating powder, 67
Modified silicone, 13
Neutral cleaners, 30, 33
NFPA Bulletin 33, 71
NFPA Industrial Fire Hazards Handbook, 71
Novaculite, 27
Nozzle blasting, 26
Nylon, 6

O

Olivine rutile, 27
Open collector cartridge filtration, 61

OSHA, 78
OSHA Section 1910.107, 71

P-Q

Peach pits, 28
Pecan shells, 28
Polyester
 carboxyl, 10
 new, 11
 urethane, 9
Polyethylene, 6
Polypropylene, 6
Polyvinyl, 6
Postheating, 73
Powder coating markets, 2
Powder delivery hoses, 50
Power spray method, 29, 30, 31
Preheating, 73
Pretreatment system, 25
Quick-color change booth, 56'

R

Rebake, 82
Recoat, 81
Recovery of oversprayed material, 55
Resistance emitters, 74
Retractable polyethylene sheeting, 55
Reverse-jet cleaning mechanism, 63
Rigid booth, 58

S

Sandblasting, 26
Self-contained booth, 59
Shot blasting, 82
Side draft spray booth, 60
Sieving devices, 49
Silica sands, 27
Silicon carbide, 28
Silicone, 13
Skin irritation, 19
Skin reactions, 78
SPC, See: statistical process control
Spray booth, 55
Statistical process control, 85
Stauroilite, 27

Storage, 78
Stratification, 41
Stripping, 82
System Components
 operation of, 71

T

Thermoplastic, 5, 6
Thermosets, 5
Thin-film epoxy, 7
Touch-up, 81
Triboelectric charging guns, 52
Troubleshooting
 black oxide, 93
 chromium phosphate, 92
 iron phosphatizing, 90
 zinc phosphatizing, 91

U-V

Uneven fluidizing distribution, 43
Variables, 85
Venturi, 47
VOCs, See: Volatile organic compounds
Volatile organic compounds, 1

W-Z

Walnut shells, 28
Wrap, 53
Zinc phosphate, 34, 38
Zinc phosphatizing, 89
Zinc phosphate processing solution, 31
Zircon, 27

