

FAP

GARY E. HUNT

P-04755
27279
PDF

Oil/Water Separation

Allan P. Fischer
ERC/Lancy
St. Paul, Minnesota



ERC/LANCY

THE LANCY CORRUGATED PLATE SEPARATOR

1.0 INTRODUCTION

"Nothing Succeeds Like Success". Since its introduction to the United States by Heil Process Equipment over ten years ago, the patented Shell Corrugated Plate Interceptor (CPI) has established an outstanding record of successful performance. Literally thousands of CPI packs are operating in hundreds of downflow Corrugated Plate Separator (CPS) installations. This successful track record was not interrupted when the CPS was transferred from Heil to ERC/Lancy in 1978 as an internal product line realignment within Dart Industries. Today, the Lancy CPS is still a leader in oil/water separation. That leadership is based on the simplicity and effectiveness of the basic CPS design.

2.0 CPI DEVELOPMENT HISTORY

The settling process is one of the oldest techniques known to separate solids from liquids, and liquids from liquids. Under ideal operating conditions, the gravity type separators will remove from the carrier fluid, all particles that have a rising or settling velocity which is equal to or greater than the overflow rate of the fluid flow through the separator.

Hazen and Camp developed relationships that apply to the removal of discrete particles in an ideal settling tank, based on the premises that the particles entering the tank are uniformly distributed over the influent cross section and that the particle is considered removed when it hits the bottom of the tank. The settling velocity of a particle which settles through a distance equal to the effective depth of the tank in a theoretical detention period can be considered as the overflow rate; V_o : and shown by the equation:

$$V_o = Q/A$$

in which Q equals the rate of flow through the tank and A equals the tank's surface area. Particles with a settling or rising velocity greater than the overflow rate, V_o will be completely removed and particles with a settling velocity of V which is less than V_o will be removed in the ratio: V/V_o . This ratio is graphically shown in Figure 1.

Hazen suggested the use of trays in the basin in order to increase the settling surface area. When the trays are operated in parallel, the flow will be reduced on each tray. The effect of the added trays is shown in Figure 2. This theory never reached much practical use since it required a means of continuously removing the sludge from each of the trays and also a means to uniformly distribute the influent to flow between each of the trays.

**FIGURE 1:
SEPARATION EFFICIENCY VS V/V_o**

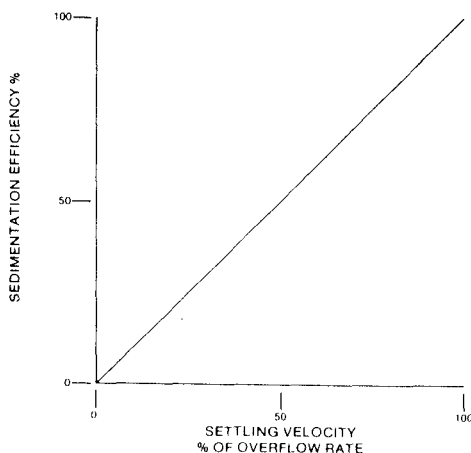
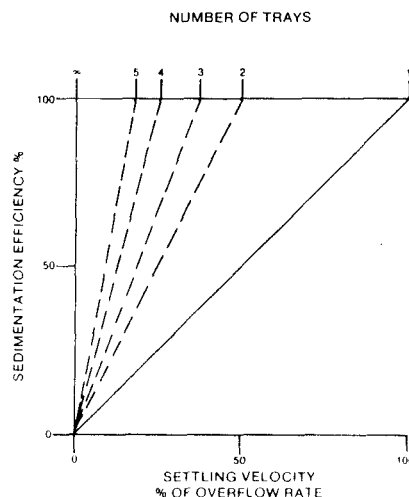

FIGURE 2: EFFECT OF ADDED TRAYS ON EFFICIENCY



Nothing much had been done to improve the settling efficiency of the basins until as a result of extensive and comprehensive research in the 1940's and 50's, the Royal Dutch Shell group was able to develop a totally different method of separation. As might be imagined, this research concentrated on separating oil from water. However, the same principles apply when removing solids from water. Shell found that the conventional oil separator which has the shape of a rectangular tank was greatly improved by applying a number of parallel plates inserted lengthwise in the tank. In this manner the oil separator was divided into a great number of shallow basins and the oil droplets had only to rise a short distance to reach the upper part of the inserted plate. Here the droplets would agglomerate and flow to the surface. This was the basis for their parallel plate interceptor (PPI) which Shell introduced in 1960.

Based on the experience gained with the Parallel Plate Interceptor, a more advanced model was developed, a Corrugated Plate Interceptor (CPI). The basic advantages over the Parallel Plate Interceptor are the low cost, self-supporting, ease of cleaning and use of corrosion-proof plates. The CPI plates are placed in the basin at a 45° angle of inclination which permits the oil to rise along the lower parts of the plates and reach the surface in large droplets via the peaks of the corrugations and especially designed oil troughs at the upper edge of the plates. The separated sludge descends along the valleys of the corrugations and is collected in troughs provided at the outlet of the plate pack. Cut-away views of a CPI pack showing this separation are shown in Figures 3a and 3b.

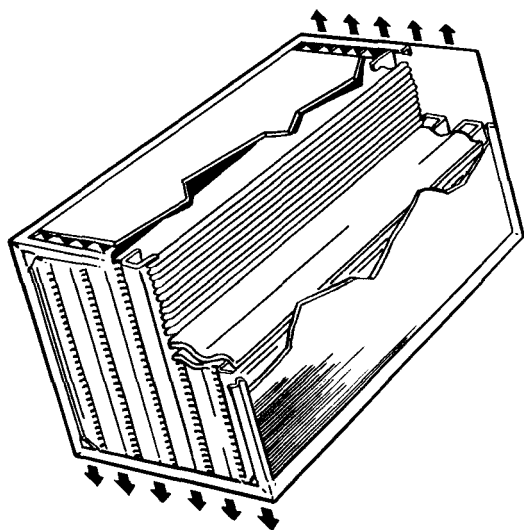

FIGURE 3a.

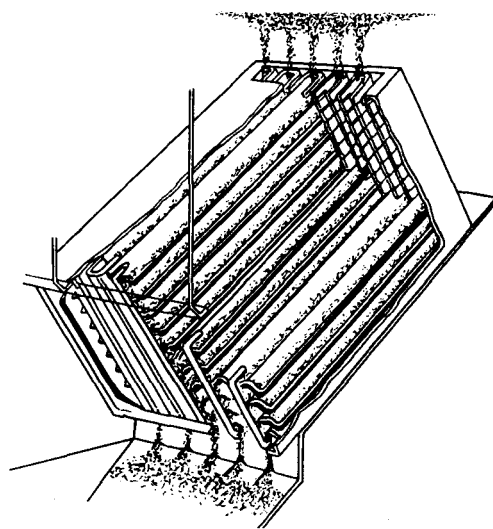

FIGURE 3b.

FIGURE 3: CPI CROSS-SECTIONS

3.0 GRAVITY SEPARATION DESIGN

3.1 Stokes Law

The basic principles of separation may be expressed mathematically and applied quantitatively. Newton postulated that the resistance to motion of a particle in a liquid medium is equal to the effective weight of the particle when the terminal velocity has been reached. When considering the rise rate of oil globules in water, Stokes law for the terminal velocity may be expressed as shown below:

$$V_r = (g/18u) (d_w - d_o) D^2$$

- where: V_r = Rising Velocity
 g = Acceleration Force of Gravity
 u = Absolute Viscosity
 d_w = Density of Water
 d_o = Density of Oil
 D = Diameter of Particle

The relationship of particle size and settling velocity is graphically illustrated in Figure 4. Gravity separation despite its seeming simplicity, is a very complicated process and there are a number of factors whose influence cannot yet be expressed as mathematical equations. In a given basin with a fixed overflow rate, the separation is influenced by two types of factors: first, those in which the sediment itself plays an important role, and secondly those which are independent of the sediment. In the first group are flow and settling velocities and the type and amount of sediment to be settled. This includes its diameter, its net density, its concentration, and the viscosity of the liquid itself. It also includes the temperature of the carrier fluid and flocculation.

In the second group, are included wall effects, kinetic and density currents as well as turbulence. These latter factors can cause short circuiting and dispersion.

Thus, after studying the literature, the designer of a gravity separator installation will realize that he is faced with the constantly varying factors referred to above. Further, he should pay attention to the hydraulic aspect when making a choice between a rectangular or circular shaped tank. In doing so he will certainly realize that neither of the two shapes are ideal from a hydraulic point of view.

FIGURE 4: SIZE/VELOCITY RELATIONSHIPS

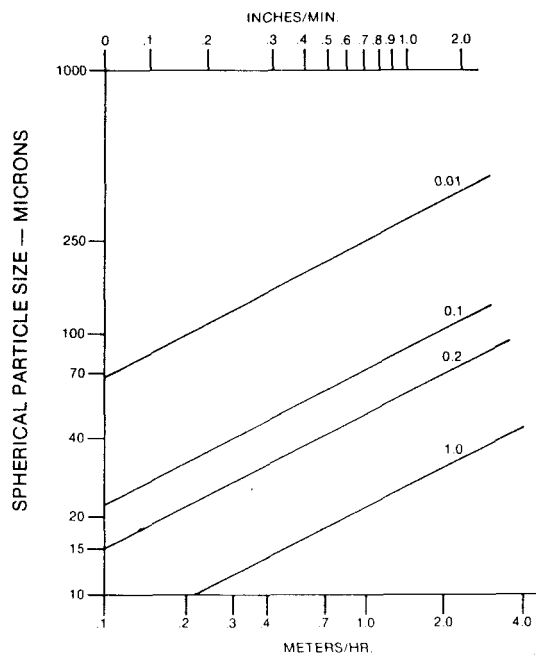

RISING OR SETTLING VELOCITY OF PARTICLES AT 68°F

3.2 Hydraulic Disturbances

Settling is influenced by various hydraulic disturbances: the main ones being turbulence, density currents and kinetic currents. Turbulence in a basin is caused by excessively high water velocity. It is also influenced by the shape of the channel. The type of flow is generally characterized by the Reynolds number. A Reynolds number of 500 or less indicates laminar flow in open channels while a Reynolds number above 2000 indicates turbulent flow. Between these values the flow may be laminar or turbulent depending upon the shape and the condition of the channel, or whether the initial flow is laminar or not.

Most API (American Petroleum Institute) type basins operate at Reynolds numbers varying from about 1000 to 2500 or even more. It is very difficult to design conventional basins with low Reynolds numbers. The CPI pack is normally, however, designed to have a Reynolds number of about 100, and is usually below 400 when handling flows as high as 265 gpm per pack. The comparison of a Reynolds number versus water temperature for a conventional API oil separator and the CPI plate pack is illustrated in Figure 5.

FIGURE 5: REYNOLDS NUMBER/TEMPERATURE RELATIONSHIPS

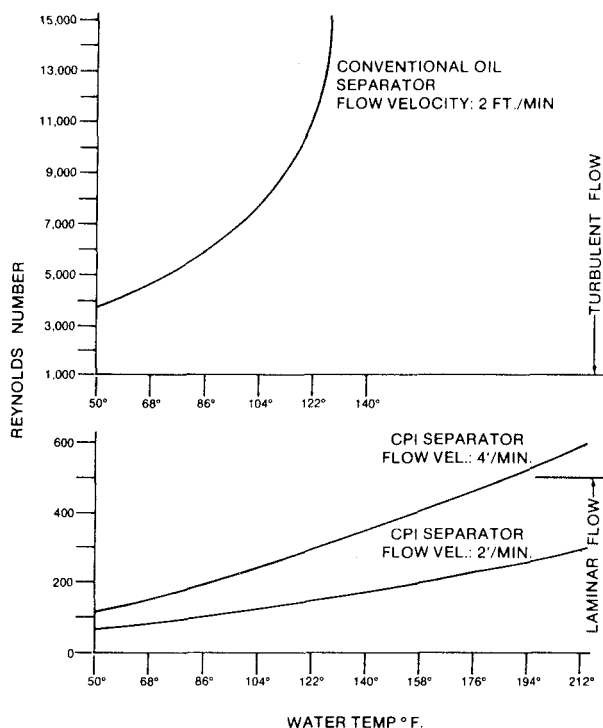

Density currents result when a liquid containing a great deal of suspended solids is heavier per unit volume than the same liquid after settling when it contains little or no suspended matter. Thus, when the cross section of the basin is very large and the water velocity is low, an incoming liquid having a higher specific gravity than the liquid in the basin will sink to the bottom and will then flow on the bottom to the outlet weir, while the surface water may turn backwards. The bottom velocity may be so high that settling is impossible or will not occur until liquid has passed through the greater portion of the basin.

This phenomena may be overcome by increasing the velocity so as to obtain a stable flow. One measure of the stability of the flow is to refer to the Froude number. The Froude number may be regarded as the ratio of the kinetic energy to the weight of a certain definite portion of the liquid. This ratio should be sufficiently high in order to produce a stable flow. Variable velocity or decreasing velocity reduces the stability of the flow. A good design basis is to always have a Froude number greater than 10^{-5} , which has given good results when settling soft coagulated water. The CPI is designed to have such stable flow for all through put over 15 gpm per plate pack.

To avoid kinetic currents, the kinetic energy in the water from the inlet pipe must be reduced and distributed uniformly over the cross sectional area. This is important, especially in wide basins or in basins divided in a number of longitudinal channels. In the CPS design the maximum flow velocity is limited to less than 1 foot a second in the inlet channel in order to have an equal flow distribution over the inlet weirs. In addition, at the head of each CPI plate pack are troughs which serve as a flow distribution baffle. This baffle effect serves to provide a slight back pressure in the flow, thus assuring equal flow distribution throughout the face area of the CPI plate pack.

4.0 CPS DESIGN AND SIZING

4.1 Corrugated Plate Interceptor (CPI)

- a. **Effective Surface Area.** The standard CPI pack consists of 47 corrugated plates, each with the projected surface area of 17.5 square feet. Since there are 46 separation compartments, the total surface area is 800 square feet. In the Corrugated Plate Separator (CPS) this 800 square foot pack is installed at a 45° angle of inclination. Therefore, the effective surface area available for settling is the horizontal projection of the pack area which equals 800 times the cosine of 45°, or 570 square feet. Less than 5% of this available area is lost due to pack turbulence so that pack effective area can conservatively be assumed to be 540 square feet.
- b. **Capacity.** As explained previously, gravity separation is a complicated phenomena. The flow capacity of a standard CPI pack is a function of a number of variables, including; 1) temperature, 2) oil particle size, and 3) specific gravity differential between the oil and carrier fluid. The nomograph shown in Figure 6 has been developed for CPI selection.

FIGURE 6: CPI SIZING CHART

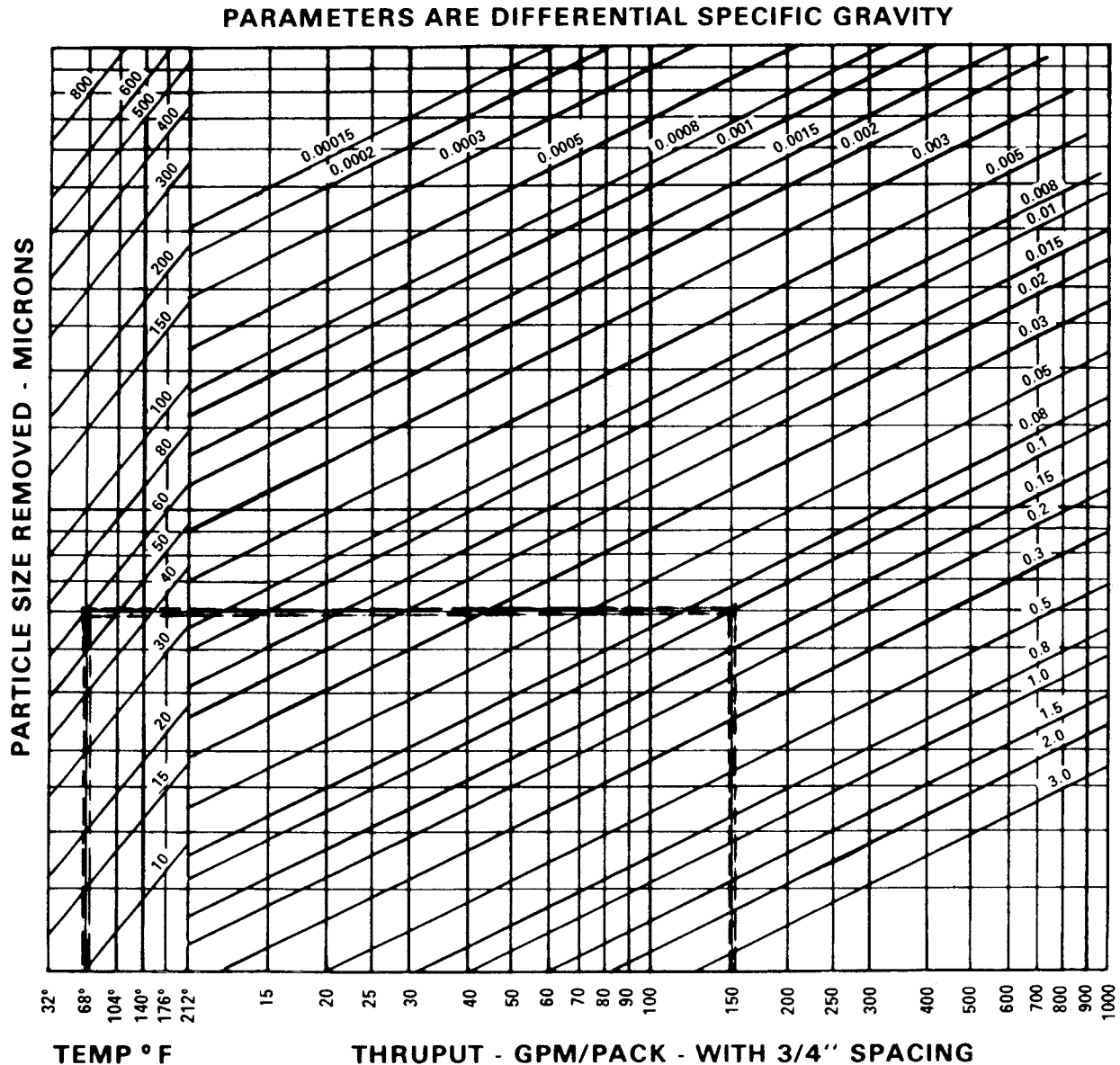

The most difficult variable to determine is the particle size distribution in the influent. Shown in Figures 7a and 7b are typical distributions empirically determined. If the CPI is selected to remove particles of a certain size, the effluent oil content is a function of the distribution of the particles in the influent and the total oil. For example, if total influent oil is 1000 ppm and 99% of the oil particles are 60 microns or larger, CPI capacity designed to remove all oil droplets 60 micron and above will yield an effluent with 10 ppm of oil.

FIGURES 7a & 7b: TYPICAL PARTICLE SIZE DISTRIBUTIONS

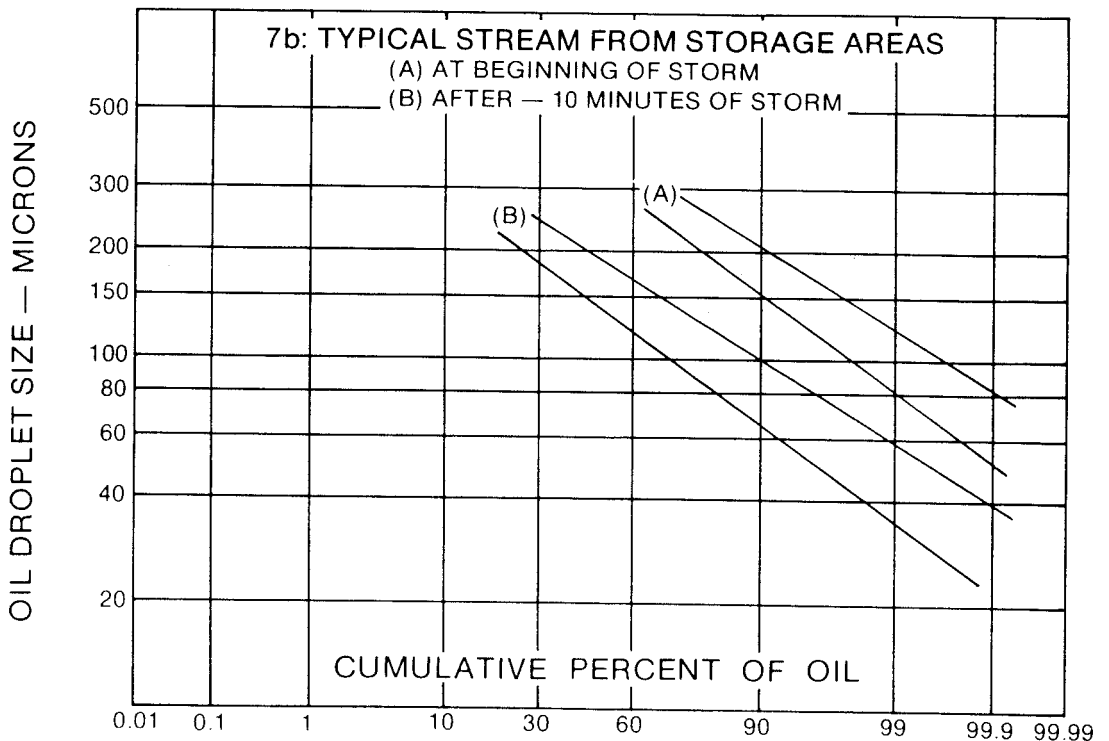
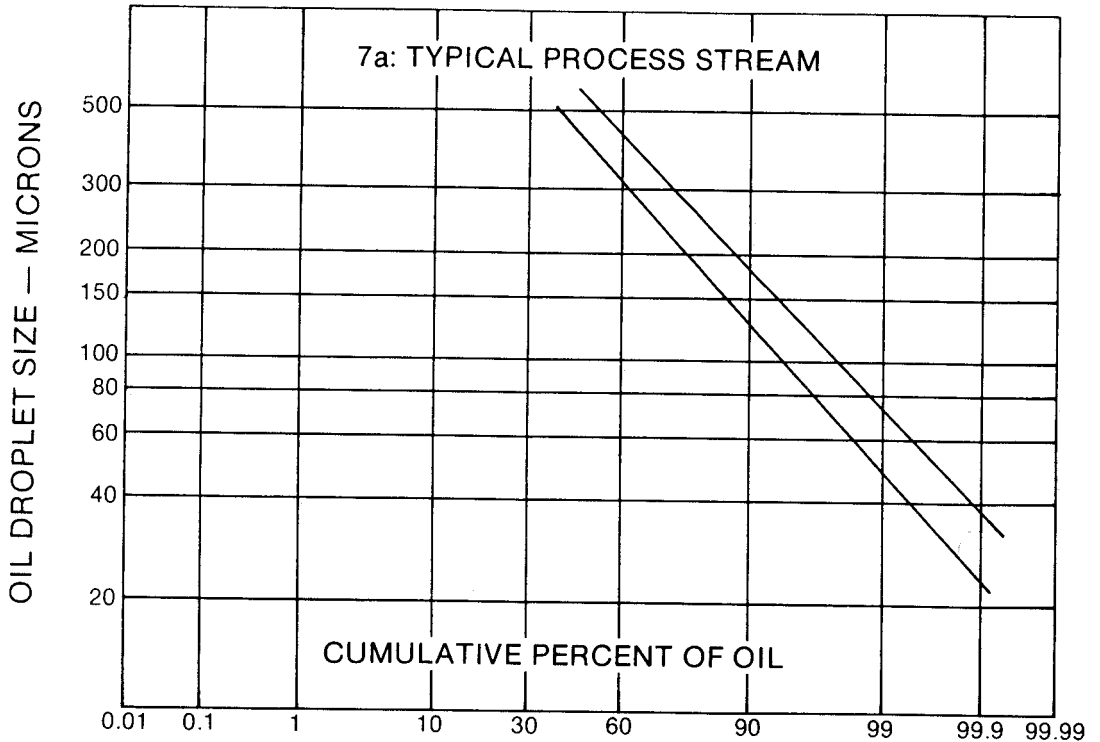

4.1 Con't. After the allowable flow per CPI pack is determined to provide the desired removal, the total number of packs is calculated by simply dividing the total flow by the value determined. Four different CPI sizes are available (see Figures 8-11). Standard multiple pack units using up to 6 of the largest CPI's can be combined in one separator to provide the total capacity required.

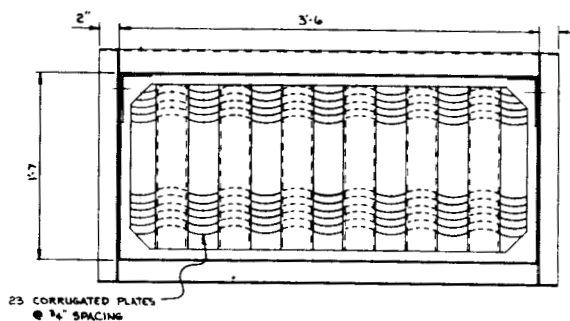
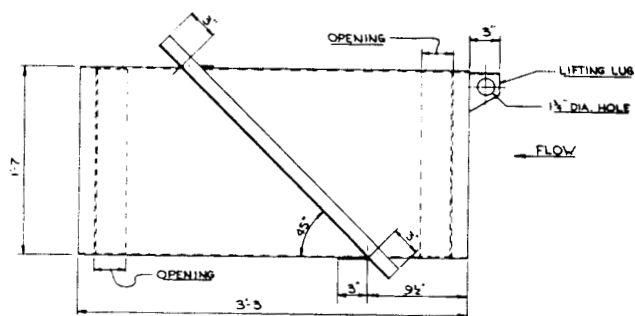
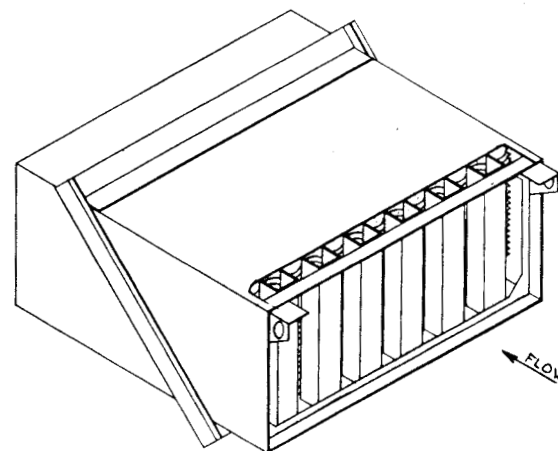
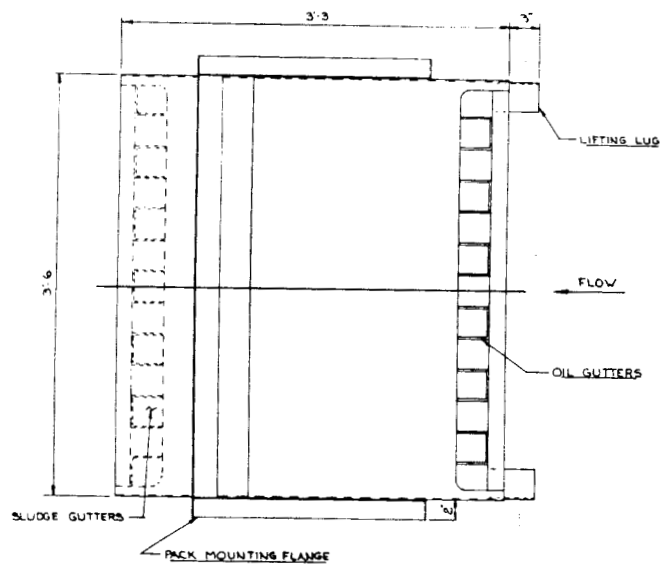

NOTES:
 MATERIAL: ISOPHTHALIC POLYESTER RESIN REINFORCED WITH FIBERGLASS
 NO. OF PLATES: 23
 PLATE SPACING: 3/4"
 PROJECTED AREA: 110 SQ. FT.
 VERTICAL RISE: 1"
 APPROX. WT.: 250 LBS.

<small>This drawing or print is the property of LANCY SYSTEMS Division of Day Environmental Services Company and is subject to copyright law. The design, layout and all other information contained herein are the property of LANCY SYSTEMS and are submitted in confidence. They are not to be used, copied, or reproduced in any way without the written consent of LANCY SYSTEMS. All patent rights are reserved and they are specifically accepted as being</small>					DRAWN RDO	DATE 7/77	C.P.I. QUARTER PACK	
					CHECKED	CLIENT		
					APPROVED			
					APPROVED			
					SCALE 2" = 1'-0"	OFFICE	PROJECT NO.	DRAWING NO.
LT	REVISION	DATE	BY	APPD.	LANCY SYSTEMS ENCLANCY DIVISION DAY ENVIRONMENT AND SERVICES CO.			

FIGURE 8: LANCY'S STANDARD 1/4 PACK

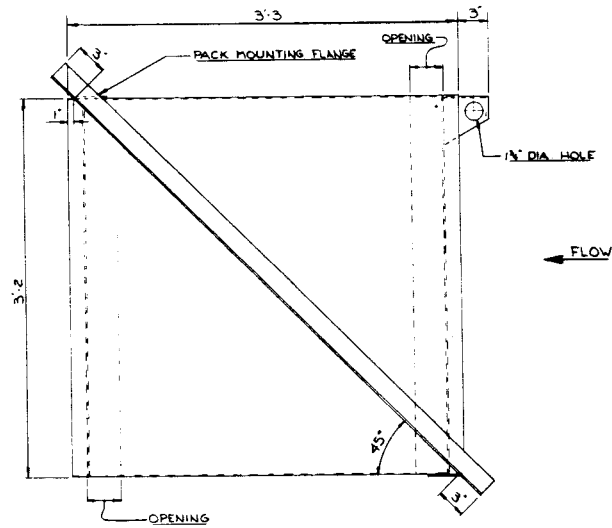
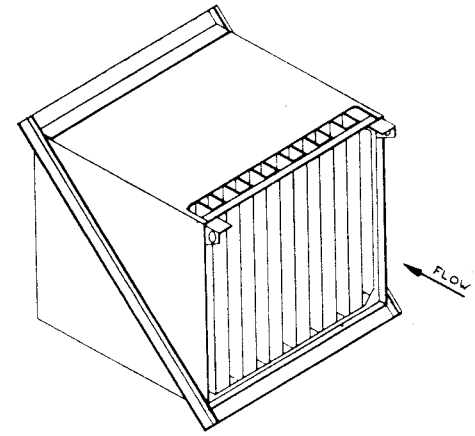
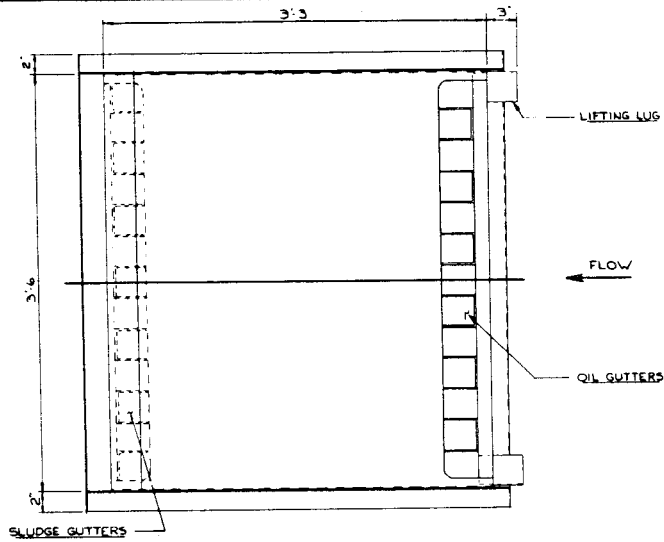

47 CORRUGATED PLATES
@ 1/2" SPACING

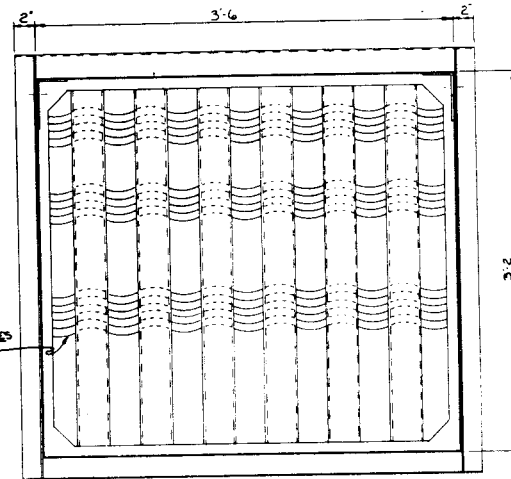

NOTES:
MATERIAL: SOPHTHALIC POLYESTER RESIN
REINFORCED WITH FIBERGLASS

NO. OF PLATES: 47
PLATE SPACING: 1/2"
PROJECTED AREA: 225 SQ. FT.
VERTICAL RISE: 1'
APPROX. WT: 400 LBS.

LT	REVISION	DATE	BY	APPRO.

This drawing or copy is the property of LANCY SYSTEMS, Inc. and is to be returned to the originator if it is to be used for any other project. The design and construction of this equipment are subject to change without notice. The user is advised that the use of this equipment is at their own risk. The user is advised that the use of this equipment is at their own risk. The user is advised that the use of this equipment is at their own risk.

DRAWN: RDO
CHECKED: []
APPROVED: []
SCALE: 2" = 1'-0"

C.P.I. HALF PACK			
CLIENT:			
LANCY SYSTEMS <small>ERC LANCY DIVISION WASTEWATER TREATMENT AND SERVICES CO.</small>			
OFFICE:	PROJECT NO:	DRAWING NO:	REV:

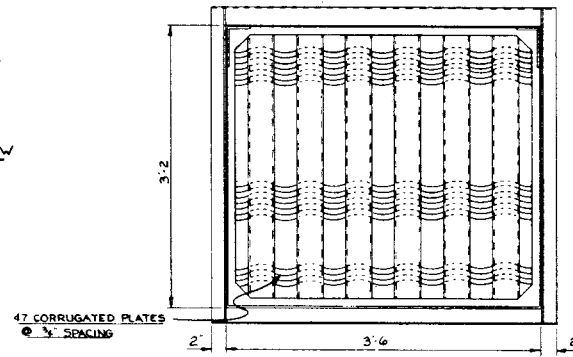
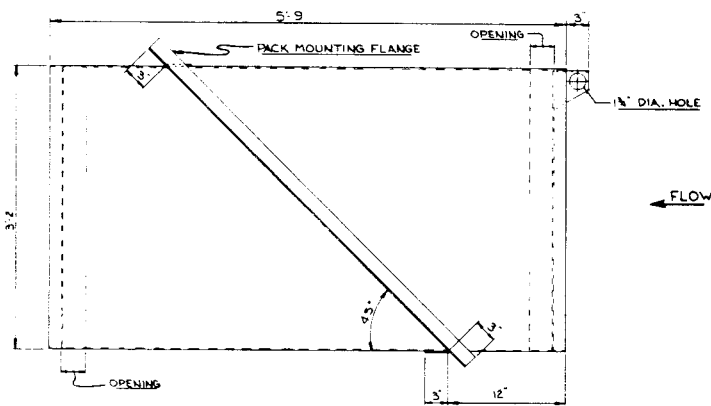
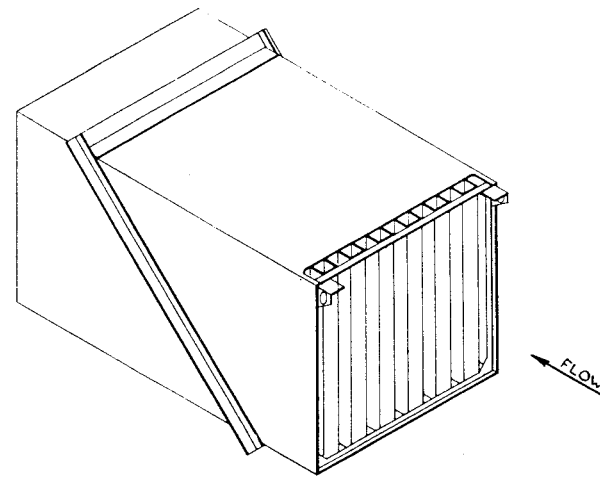
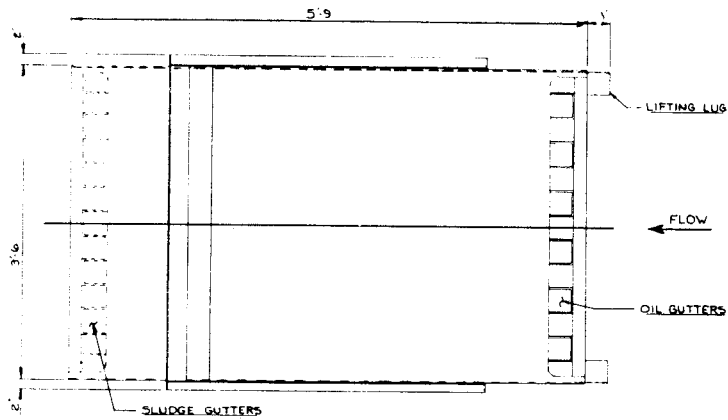

NOTES:
 MATERIAL: ISOPHTHALIC POLYESTER RESIN
 REINFORCED WITH FIBERGLASS
 NO. OF PLATES: 47
 PLATE SPACING: 1/2"
 PROJECTED AREA: 530 SQ. FT.
 VERTICAL RISE: 1"
 APPROX. W.T.: 700 LBS.

					DRAWN RDO CHECKED APPROVED APPROVED SCALE 1 1/2" = 1'-0"	DATE 3/4/79 CLIENT LANCY SYSTEMS <small>ERC LANCY DIVISION DATE ENVIRONMENT AND SERVICES CO.</small>		
LT	REVISION	DATE	BY	APP'D	OFFICE	PROJECT NO.	DRAWING NO.	REV

FIGURE 10: LANCY'S STANDARD FULL PACK

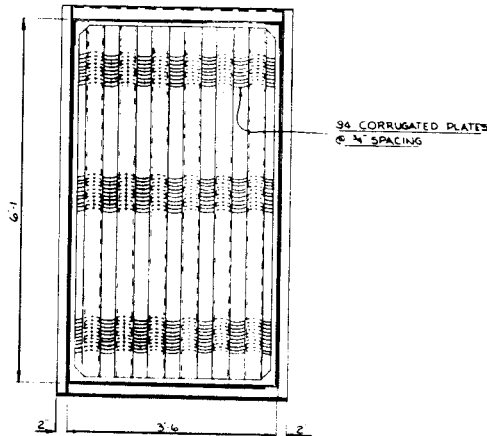
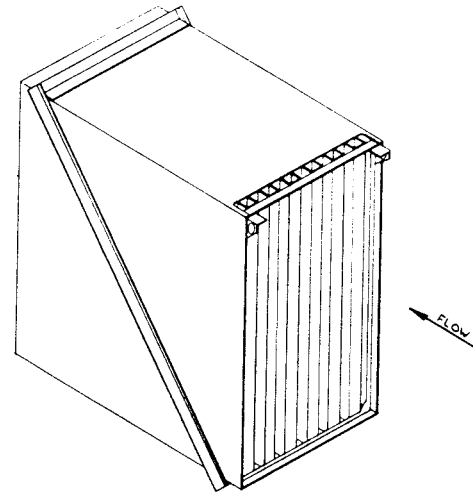
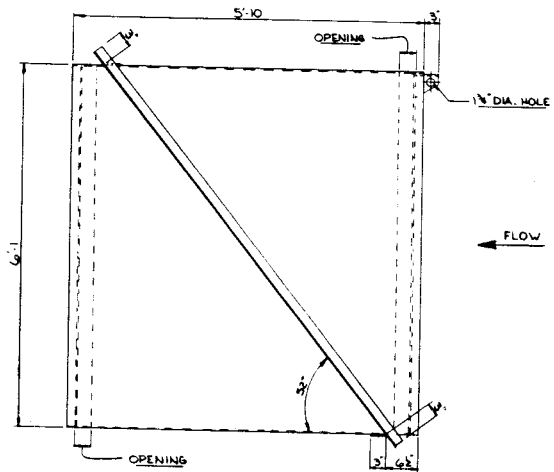
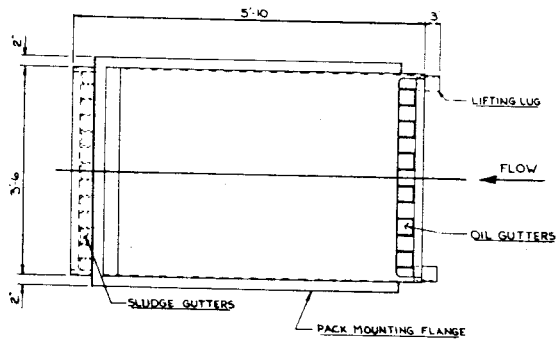

NOTES:
 MATERIAL: ISOPHTHALIC POLYESTER RESIN
 REINFORCED WITH FIBERGLASS
 NO. OF PLATES: 96
 PLATE SPACING: 3/4"
 PROJECTED AREA: 1100 SQ. FT.
 VERTICAL RISE: 1'
 APPROX. WT.: 1350 LBS.

This drawing, in print, is the property of LANCY SYSTEMS, Division of Dart Environmental and Services Company and is subject to return on request. The design concepts and information contained herein are proprietary to this company and are submitted in confidence. They are not to be used, in whole or in part, for the purpose for which the print is expressed, unless they are otherwise used in any manner authorized by the interest of LANCY SYSTEMS. All drawings are prepared unless they are specifically assigned in writing.				DRAWN RDO	DATE 7/73	C.P.I. DOUBLE PACK	
				CHECKED	CLIENT		
				APPROVED			
				APPROVED			
				SCALE 1" = 1'-0"	OFFICE	PROJECT NO.	DRAWING NO.
REVISION	DATE	BY	APPD.	LANCY SYSTEMS			
				ERC LANCY DIVISION DART ENVIRONMENTAL AND SERVICES CO.			
				REV	REV	REV	REV

FIGURE 11 - LANCY SYSTEMS

4.2 Corrugated Plate Separator

- a. **Basic Designs.** The CPI is installed at a 45° angle of inclination in a steel, concrete or fiberglass reinforced plastic basin to form a Corrugated Plate Separator (CPS). The basin is equipped with adjustable oil and effluent weirs. A typical steel basin design is illustrated in Figure 12. The operation of the CPS is explained below. If the influent contains significant solids, a presettling chamber is recommended such as shown in Figure 13. For flow containing small particles (down to 20 microns), coalescing media may be added (Figure 14).
- b. **Operation.** The Lancy CPS operates in the downflow mode as shown in Figures 12-14. The influent flows into a quiescent zone located ahead of the CPI Pack. In this area the liquids velocities are slowed so that by the time the liquids reach the CPI they are laminar. The flow is then downward through the pack. The lighter gravity liquid rises to the peaks of the corrugations and continues to rise until reaching the troughs located at the inlet of the pack. The lighter fluid then rises unimpeded by the main flow stream to the bucket weir. The heavier liquid flows out the lower portion of the pack to the effluent trough. If any solids are present in the influent, separation also occurs according to Stokes Law. These solids collect in the valleys of the corrugations and are collected in troughs located at the pack outlet. These channels direct the solids to the bottom of the separator basin and assure no reentrainment with the effluent liquid.

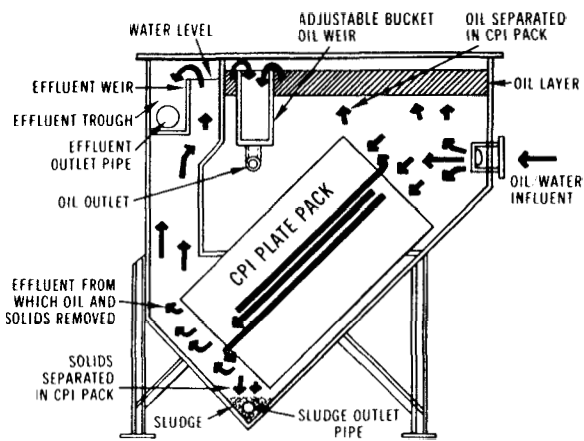

FIGURE 12:
LANCY'S STANDARD BPR DESIGN

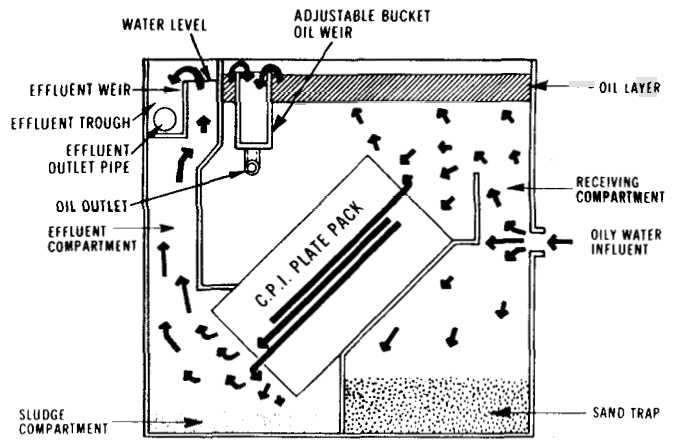

FIGURE 13:
LANCY'S STANDARD BPR-S/S DESIGN

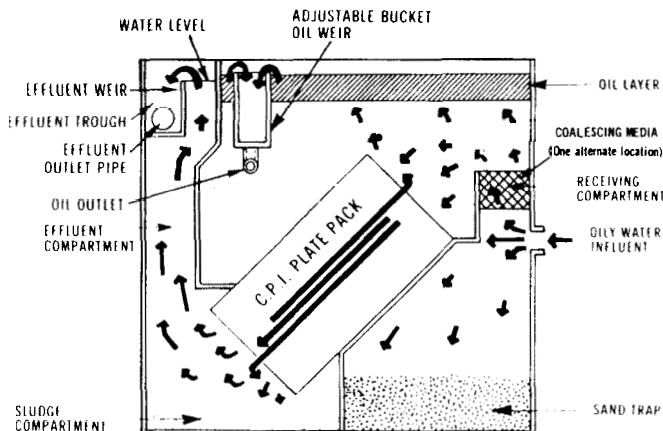

FIGURE 14: LANCY'S STANDARD CPS WITH COALESCING MEDIA

c. **Downflow Design Advantages.** In comparison to conventional API separators the Lancy CPS has the following advantages:

- 1) Low cost, shop fabrication
- 2) Greater removal efficiency
- 3) Lower space requirements

The downflow design also has advantages when compared to crossflow CPS units. Because of the greater turbulence at the inlet to the crossflow packs, only 90% of the available pack area is available for separation versus 95% for the downflow. The crossflow design is also more susceptible to clogging with solids. This is because solids are more likely to settle out in the first few corrugations on the inlet side. In the downflow design, solids are more evenly distributed over all corrugations so that none are excessively loaded. Also, having the direction of flow the same as the solids flow helps keep the solids moving toward the bottom of the separator.

5.0 CPS SYSTEMS

5.1 Emulsified Oils

Emulsified oil is defined as discrete oil droplets generally down to less than one micron in size. Therefore, they will not rise to the surface no matter how much rising time is allowed. Emulsified oil in the waste water can be generally found to originate due to highly alkaline discharges into the waste water stream or a high concentration of detergents. Thus, it is best to segregate this type of stream and treat it separately. Emulsified oil can economically be removed by breaking the emulsion with heat, acids, or polyelectrolytes and passing through a CPS system similar to that shown previously in Figure 14. Another economical method is by a floatation type corrugated plate separator shown in Figure 15. This system also has the advantage of removing small concentrations of dissolved oil. A system such as this generally gives an effluent of less than 5 ppm provided there is no high concentration of dissolved oil in the influent.

FIGURE 15: CPS SYSTEM FOR EMULSIFIED OILS

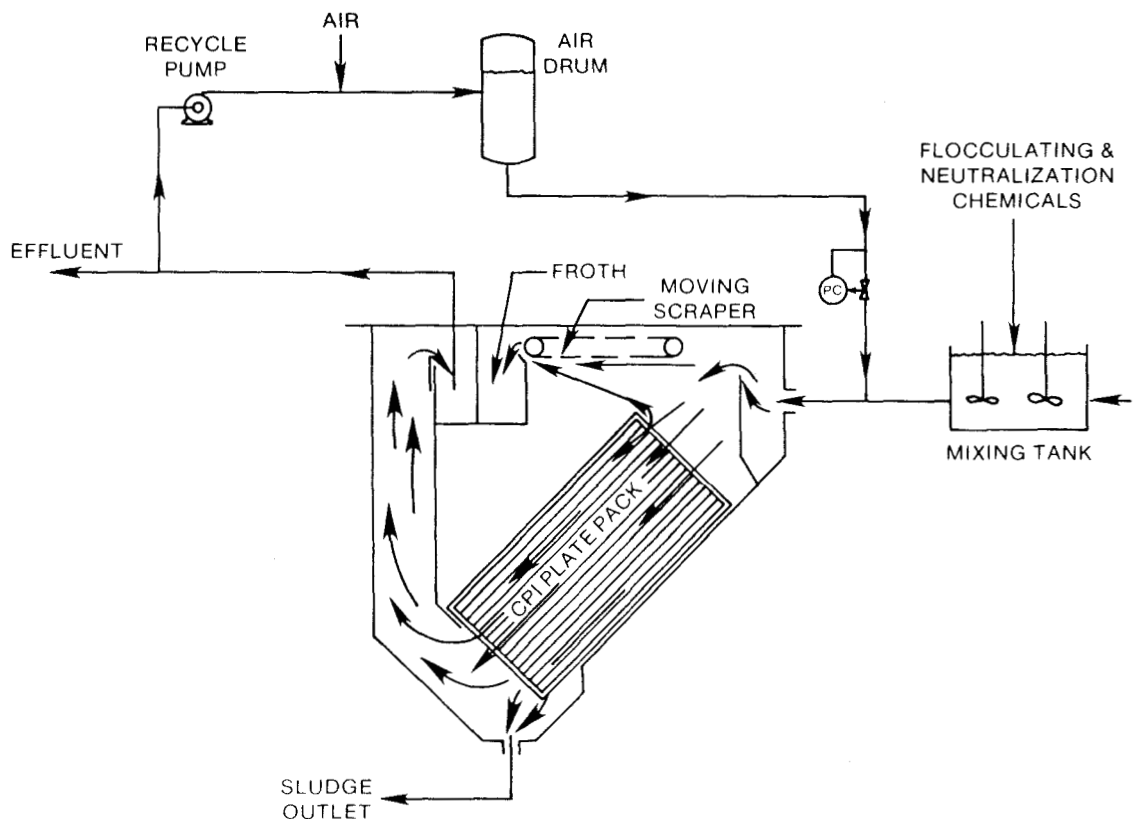

5.2 Dissolved Oil

The third form that oil may appear in the waste stream is as dissolved oil. Dissolved oil is oil that is no longer present in droplet size. Short chain hydrocarbons such as Pentanes and Hexanes have very limited solubility in water while long chain hydrocarbons are practically insoluble. Aromatic compounds, however, such as Benzene, Toluene and Xylenes as well as Phenols are quite soluble in water and are generally considered as oil in most analyses. Dissolved oil is difficult and expensive to remove, therefore, again it should be treated separately from the main body of the waste water. Similar to emulsified oils, dissolved oils are generally removed by using various chemical aids and mechanical processes. Some of these oils might even best be removed by a biologically activated sludge system. The sludge that is carried through would be removed by reverse flow through a Corrugated Plate Separator such as shown in Figure 16.

FIGURE 16: CPS SYSTEM FOR DISSOLVED OILS

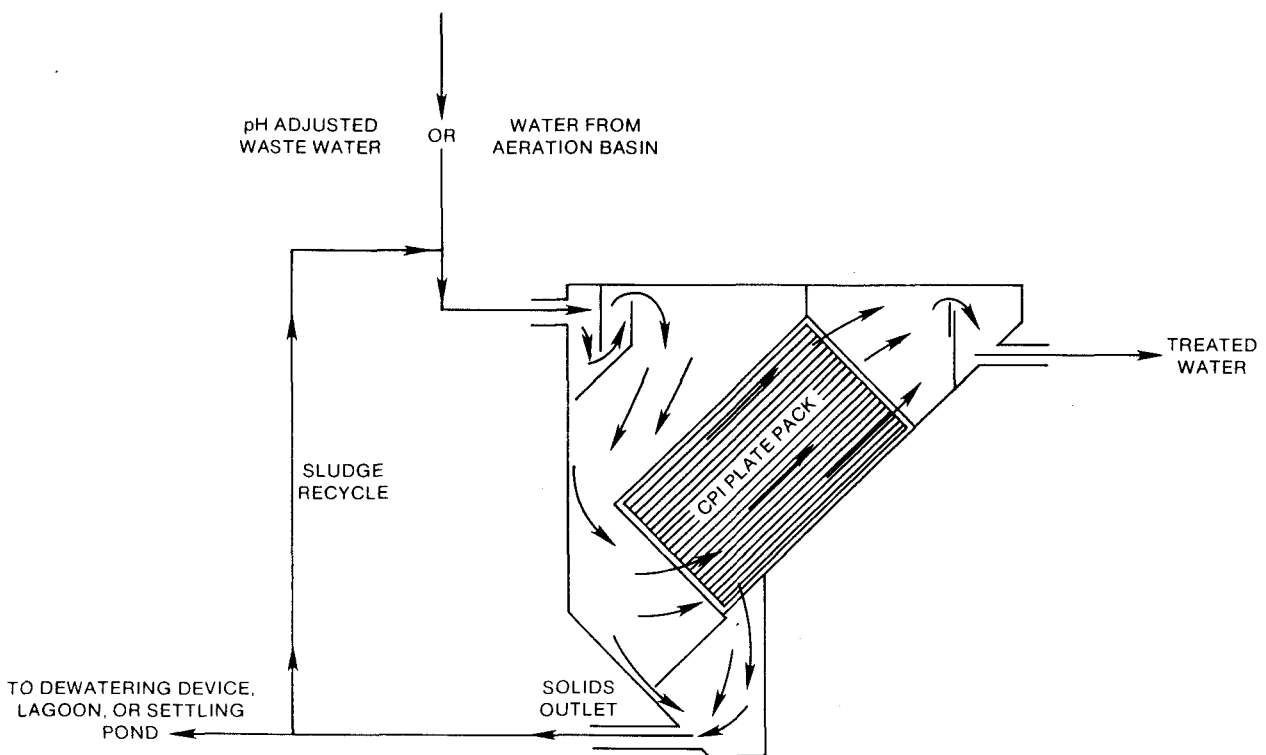

6.0 SUMMARY

The Lancy Corrugated Plate Separator has proved itself to be a cost-effective, efficient means of separating oil and other liquids from waste and process streams. The Lancy design effectively balances the dynamic variables associated with gravity separation and has the flexibility to meet varied requirements. If special separation problems exist, the CPS can be combined with other equipment items in a pre-packaged separation system.