

Air

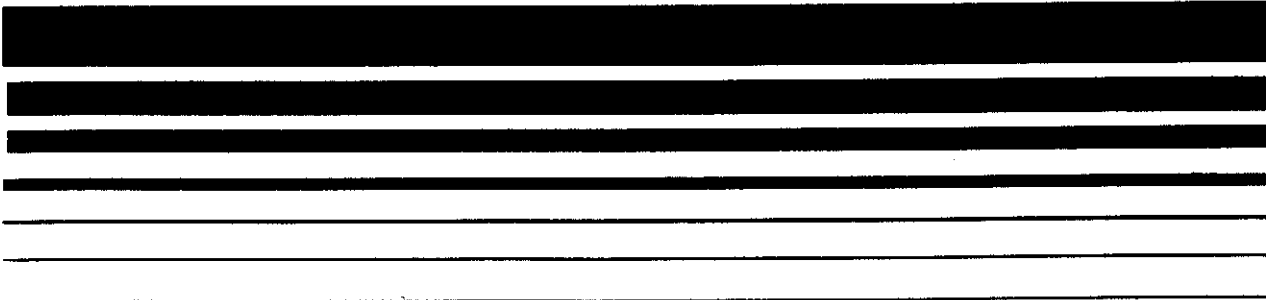

Alternative Control Techniques Document: Volatile Organic Liquid Storage in Floating and Fixed Roof Tanks



ACT

Alternative Control Techniques Document: Volatile Organic Liquid Storage in Floating and Fixed Roof Tanks

Emissions Standards Division

U.S. ENVIRONMENTAL PROTECTION AGENCY

Office of Air and Radiation

Office of Air Quality Planning and Standards

Research Triangle Park, North Carolina 27711

January 1994

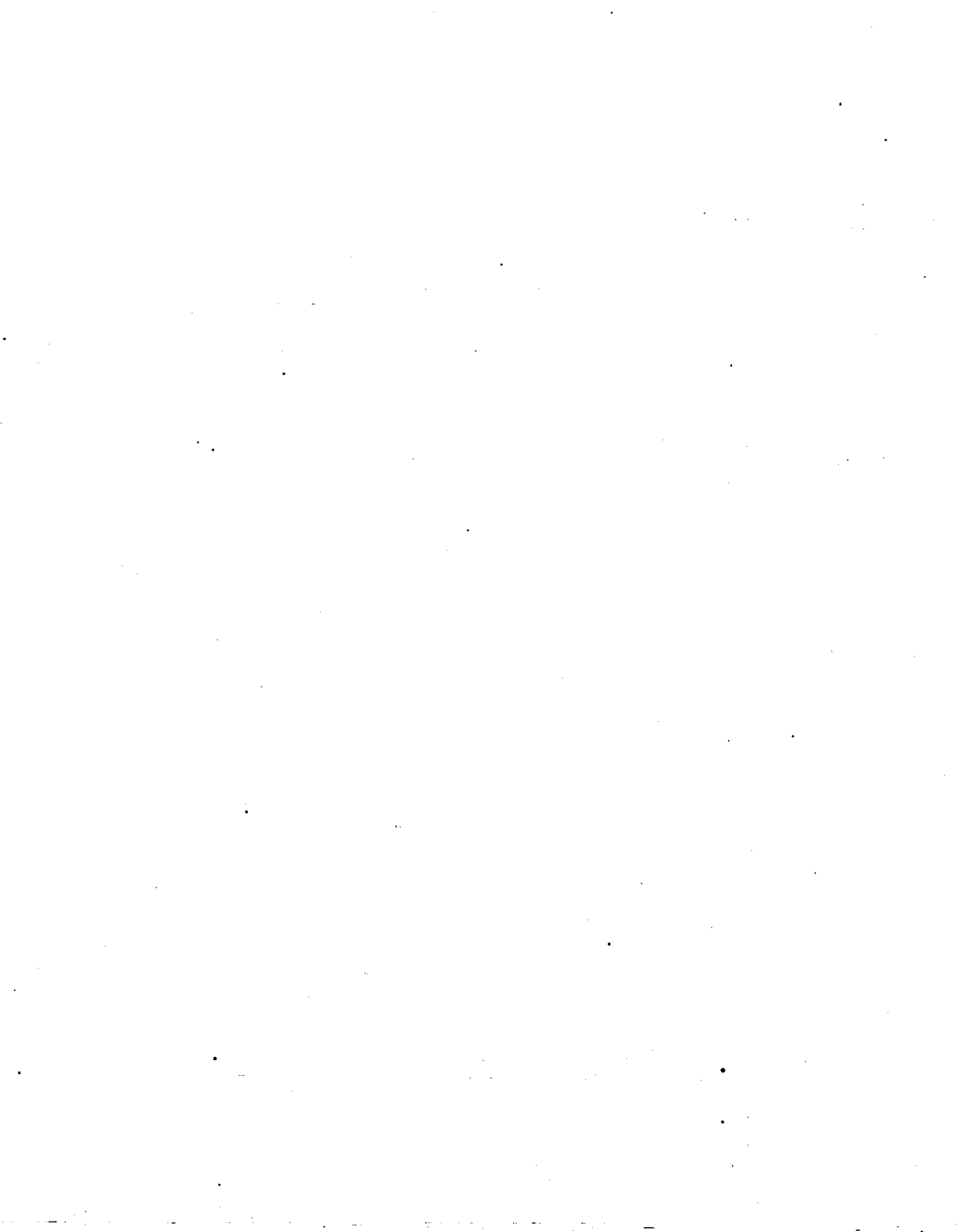

TABLE OF CONTENTS

	<u>Page</u>
1.0 INTRODUCTION	1-1
2.0 STORAGE TANK DESCRIPTIONS	2-1
2.1 INTRODUCTION	2-1
2.2 TYPES OF STORAGE TANKS	2-1
2.2.1 Fixed-Roof Tanks	2-1
2.2.2 External Floating Roof Tanks	2-2
2.2.3 Internal Floating Roof Tanks	2-2
2.2.4 Horizontal Tanks	2-5
2.3 TYPES OF FLOATING ROOF PERIMETER SEALS	2-5
2.3.1 External Floating Roof Seals	2-5
2.3.2 Internal Floating Roof Seals	2-8
2.4 TYPES OF FLOATING ROOF DECK FITTINGS	2-10
2.4.1 External Floating Roof Fittings	2-10
2.4.2 Internal Floating Roof Fittings	2-13
2.5 REFERENCES	2-33
3.0 EMISSION ESTIMATION PROCEDURES AND REGULATORY BASELINE	3-1
3.1 INTRODUCTION	3-1
3.2 STORAGE TANK EMISSIONS AND EMISSION EQUATIONS .	3-1
3.2.1 Fixed-Roof Tank Emissions	3-1
3.2.2 Horizontal Tank Emissions	3-4
3.2.3 External Floating Roof Tank Emissions .	3-5
3.2.4 Internal Floating Roof Tank Emissions .	3-15
3.3 REGULATORY BASELINE	3-27
3.3.1 Petroleum Liquid Storage NSPS (Subpart K)	3-28
3.3.2 Petroleum Liquid Fixed-Roof Tank CTG . .	3-28
3.3.3 Petroleum Liquid External Floating Roof Tank CTG	3-29
3.3.4 Subpart Ka NSPS	3-29
3.3.5 Volatile Organic Liquid NSPS	3-30
3.3.6 Results of Regulatory Actions	3-31

TABLE OF CONTENTS (continued)

	<u>Page</u>
3.4 MODEL LIQUIDS AND MODEL TANKS	3-32
3.4.1 Model Liquids	3-32
3.4.2 Model Tanks	3-33
3.5 REFERENCES	3-40
4.0 CONTROL TECHNIQUES	4-1
4.1 OVERVIEW	4-1
4.2 FIXED ROOF TANKS	4-4
4.3 INTERNAL FLOATING ROOF TANKS	4-5
4.3.1 Controls for Fitting Losses	4-6
4.3.2 Controls for Seal Losses	4-6
4.3.3 Deck Seam Losses	4-8
4.4 EXTERNAL FLOATING ROOF TANKS	4-8
4.4.1 Controls for Fitting Losses	4-10
4.4.2 Controls for Withdrawal Losses	4-12
4.4.3 Controls For Rim or Seal Losses	4-12
4.5 VAPOR CONTROL OR RECOVERY SYSTEMS ON FIXED ROOF TANKS	4-14
4.5.1 Carbon Adsorption	4-14
4.5.2 Oxidation Units	4-15
4.5.3 Refrigerated Vent Condensers	4-16
4.5.4 Control Efficiencies of Vapor Recovery or Control Systems	4-16
4.6 RETROFIT CONSIDERATIONS	4-16
4.6.1 Fixed Roof Tanks With Internal Floating Roofs	4-17
4.6.2 Secondary Seals on Existing Internal Floating Roofs	4-17
4.6.3 Liquid-Mounted Seals on Existing Internal Floating Roofs	4-17
4.6.4 Rim-Mounted Secondary Seals on External Floating Roofs	4-18
4.6.5 Self-Supporting Fixed Roofs on External Floating Roof Tanks	4-18
4.7 PROBLEM LIQUIDS AND MATERIALS OF CONSTRUCTION	4-18
4.8 REFERENCES	4-19

TABLE OF CONTENTS (continued)

	<u>Page</u>
5.0 ENVIRONMENTAL IMPACTS OF CONTROL OPTIONS	5-1
5.1 ENVIRONMENTAL IMPACTS	5-1
5.2 FIXED ROOF MODEL TANKS	5-1
5.2.1 Emissions Reductions	5-2
5.2.2 Secondary Impacts	5-3
5.3 INTERNAL FLOATING ROOF TANKS	5-5
5.3.1 Emissions Reductions	5-6
5.3.2 Secondary Impacts	5-6
5.4 EXTERNAL FLOATING ROOF TANKS	5-6
5.4.1 Emissions Reductions	5-7
5.4.2 Secondary Impacts	5-7
5.5 NATIONWIDE IMPACTS OF CONTROL OPTIONS	5-8
5.5.1 Fixed-Roof Tanks	5-10
5.5.2 Internal Floating Roof Tanks	5-10
5.5.3 External Floating Roof Tanks	5-11
5.6 REFERENCES	5-24
6.0 COST ANALYSIS OF CONTROL OPTIONS	6-1
6.1 INTRODUCTION	6-1
6.2 EQUIPMENT COSTS	6-2
6.3 MODEL TANK COSTS	6-4
6.4 NATIONWIDE COST IMPACTS	6-5
6.5 UNCERTAINTIES	6-6
6.6 REFERENCES	6-33
APPENDIX A	A-1
APPENDIX B	B-1



LIST OF FIGURES

		<u>Page</u>
Figure 2-1.	Typical fixed roof tank	2-16
Figure 2-2.	External floating roof tank (pontoon type)	2-17
Figure 2-3.	External floating roof tank (double-deck type)	2-18
Figure 2-4.	Internal floating roof tanks	2-19
Figure 2-5.	Typical underground storage tank	2-20
Figure 2-6.	A typical above-ground horizontal tank . .	2-21
Figure 2-7.	Primary seals	2-22
Figure 2-8.	Rim-mounted secondary seals on external floating roofs	2-23
Figure 2-9.	Metallic shoe seal with shoe-mounted secondary seal	2-24
Figure 2-10.	Typical flotation devices and perimeter seals for internal floating roofs	2-25
Figure 2-11.	Rim-mounted secondary seal on internal floating roof	2-26
Figure 2-12.	Access hatch	2-27
Figure 2-13a.	Unslotted guide-pole well	2-28
Figure 2-13b.	Slotted guide-pole/sample well	2-28
Figure 2-14a.	Gauge-float well	2-29
Figure 2-14b.	Gauge-hatch/sample well	2-29
Figure 2-15.	Vacuum breaker	2-30
Figure 2-16a.	Overflow roof drain	2-31
Figure 2-16b.	Roof leg	2-31
Figure 2-17.	Rim vent	2-32

LIST OF FIGURES (continued)

	<u>Page</u>
Figure 3-1. Total roof fitting loss factor for typical fittings on pontoon floating roofs	3-12
Figure 3-2. Total roof fitting loss factor for typical fittings on double-deck floating roofs	3-13
Figure 3-3. Total deck fitting loss factor as a function of tank diameter, for a self-supporting fixed roof	3-25
Figure 3-4. Total deck fitting loss factor as a function of tank diameter, for a column-supported fixed roof	3-26
Figure 5-1. The effects of turnover rates and stored liquid vapor pressure on emissions from fixed-roof tanks storing a model VOL	5-12
Figure 5-2. The effects of turnover rates and stored liquid vapor pressure on emissions from fixed-roof tanks storing a model crude oil	5-13
Figure 5-3. The effect of the control options on emissions from fixed-roof tanks storing VOL as a function of tank volume	5-14
Figure 5-4. The effect of the control options on emissions from fixed-roof tanks storing VOL as a function of tank volume	5-15
Figure 5-5. The effect of the control options on emissions from fixed-roof tanks storing VOL as a function of tank volume	5-16
Figure 5-6. The effect of the control options on emissions from internal floating roof tanks storing VOL as a function of tank volume	5-17
Figure 5-7. The effect of the control options on emissions from internal floating roof tanks storing crude oil as a function of tank volume	5-18

LIST OF FIGURES (continued)

	<u>Page</u>
Figure 5-8. The effect of the control options on emissions from external floating roof tanks equipped with mechanical shoe seals as a function of tank volume	5-19
Figure 5-9. The effect of the control options on emissions from external floating roof tanks equipped with vapor-mounted primary seals as a function of tank volume	5-20
Figure 6-1. The cost-effectiveness of control options on fixed-roof tanks storing VOL as a function of tank volume	6-7
Figure 6-2. The cost-effectiveness of control options on fixed-roof tanks storing VOL as a function of tank volume	6-8
Figure 6-3. The cost-effectiveness of control options on fixed-roof tanks storing VOL as a function of tank volume	6-9
Figure 6-4. The cost-effectiveness of control options on fixed-roof tanks storing VOL as a function of tank volume	6-10
Figure 6-5. The cost-effectiveness of control options on fixed-roof tanks storing VOL as a function of tank volume	6-11
Figure 6-6. The cost-effectiveness of control options on fixed-roof tanks storing VOL as a function of tank volume	6-12
Figure 6-7. The cost-effectiveness of control options on fixed-roof tanks storing crude oil as a function of tank volume	6-13
Figure 6-8. The cost-effectiveness of control options on fixed-roof tanks storing crude oil as a function of tank volume	6-14
Figure 6-9. The cost-effectiveness of control options on fixed-roof tanks storing crude oil as a function of tank volume	6-15

LIST OF FIGURES (continued)

	<u>Page</u>
Figure 6-10. The cost-effectiveness of control options on fixed-roof tanks storing crude oil as a function of tank volume	6-16
Figure 6-11. The cost-effectiveness of control options on fixed-roof tanks storing crude oil as a function of tank volume	6-17
Figure 6-12. The cost-effectiveness of control options on fixed-roof tanks storing crude oil as a function of tank volume	6-18
Figure 6-13. The cost-effectiveness of control options on internal floating roof tanks storing VOL as a function of tank volume	6-19
Figure 6-14. The cost-effectiveness of control options on internal floating roof tanks storing VOL as a function of tank volume	6-20
Figure 6-15. The cost-effectiveness of control options on internal floating roof tanks storing VOL as a function of tank volume	6-21
Figure 6-16. The cost-effectiveness of control options on internal floating roof tanks storing crude oil as a function of tank volume	6-22
Figure 6-17. The cost-effectiveness of control options on internal floating roof tanks storing crude oil as a function of tank volume	6-23
Figure 6-18. The cost-effectiveness of control options on internal floating roof tanks storing crude oil as a function of tank volume	6-24
Figure 6-19. The cost-effectiveness of control options on external floating roof tanks equipped with mechanical shoe primary seals storing VOL as a function of tank volume and vapor pressure	6-25
Figure 6-20. The cost-effectiveness of control options on external floating roof tanks equipped with mechanical shoe primary seals storing crude oil as a function of tank volume and vapor pressure	6-26

LIST OF FIGURES (continued)

	<u>Page</u>
Figure 6-21. The cost-effectiveness of control options on external floating roof tanks equipped with vapor-mounted primary seals storing VOL as a function of tank volume and vapor pressure	6-27
Figure 6-22. The cost-effectiveness of control options on external floating roof tanks equipped with vapor-mounted primary seals storing crude oil as a function of tank volume and vapor pressure	6-28



LIST OF TABLES

		<u>Page</u>
TABLE 3-1.	PAINT FACTORS FOR FIXED-ROOF TANKS	3-3
TABLE 3-2.	RIM SEAL LOSS FACTORS, K_R AND N	3-7
TABLE 3-3.	ROOF FITTING LOSS FACTORS, K_{F1} , K_{F2} , AND m , AND TYPICAL NUMBER OF ROOF FITTINGS, N_T	3-9
TABLE 3-4.	TYPICAL NUMBER OF VACUUM BREAKERS, N_{F6} , AND ROOF DRAINS, N_{F7}	3-10
TABLE 3-5.	TYPICAL NUMBER OF ROOF LEGS, N_{F8}	3-11
TABLE 3-6.	AVERAGE CLINGAGE FACTORS (C) bbl/1,000 ft ²	3-16
TABLE 3-7.	PHYSICAL PROPERTIES OF SELECTED PETROCHEMICALS	3-17
TABLE 3-8.	TYPICAL NUMBER OF COLUMNS AS A FUNCTION OF TANK DIAMETERS	3-22
TABLE 3-9.	EFFECTIVE COLUMN DIAMETER (F_C)	3-22
TABLE 3-10.	SUMMARY OF DECK FITTING LOSS FACTORS (K_F) AND TYPICAL NUMBER OF FITTINGS (N_F) .	3-24
TABLE 3-11.	FIXED ROOF MODEL TANKS	3-34
TABLE 3-12.	ANALYTICAL FRAMEWORK FOR INTERNAL FLOATING ROOF AND EXTERNAL FLOATING ROOF MODEL PLANTS	3-38
TABLE 4-1.	FIXED ROOF AND INTERNAL FLOATING ROOF TANKS--HIERARCHY OF EQUIPMENT TYPES BASED ON EMISSIONS RATE	4-2
TABLE 4-2.	EXTERNAL FLOATING ROOF TANKS -- HIERARCHY OF EQUIPMENT TYPES BASED ON EMISSIONS RATE	4-3
TABLE 4-3	"CONTROLLED" AND "UNCONTROLLED" INTERNAL FLOATING ROOF DECK FITTINGS	4-7
TABLE 4-4.	INTERNAL FLOATING ROOF RIM SEAL SYSTEMS SEAL LOSS FACTORS AND CONTROL EFFICIENCIES	4-9

LIST OF TABLES (continued)

PAGE

TABLE 4-5.	"CONTROLLED" AND "UNCONTROLLED" EXTERNAL FLOATING ROOF DECK FITTINGS	4-11
TABLE 4-6.	EXTERNAL FLOATING ROOF TANK SEAL SYSTEM CONTROL EFFICIENCIES	4-13
TABLE 5-1.	NATIONWIDE ENVIRONMENTAL IMPACTS OF THE FIXED-ROOF TANK CONTROL OPTIONS	5-21
TABLE 5-2.	NATIONWIDE ENVIRONMENTAL IMPACTS OF THE INTERNAL FLOATING ROOF TANK CONTROL OPTIONS	5-22
TABLE 5-3.	NATIONWIDE SECONDARY ENVIRONMENTAL IMPACTS OF THE INTERNAL FLOATING ROOF TANK CONTROL OPTIONS	5-23
TABLE 6-1.	ESTIMATED INSTALLED CAPITAL COST OF INTERNAL FLOATING ROOFS (1991 DOLLARS)	6-29
TABLE 6-2.	NATIONWIDE COST IMPACTS FOR FIXED-ROOF TANK OPTIONS	6-30
TABLE 6-3.	NATIONWIDE COST IMPACTS FOR INTERNAL FLOATING ROOF TANK OPTIONS	6-31
TABLE 6-4.	NATIONWIDE COST IMPACTS FOR EXTERNAL FLOATING ROOF TANK OPTIONS	6-32
TABLE B-1.	INCREMENTAL COST-EFFECTIVENESS WITHIN EACH CONTROL OPTION FOR FIXED-ROOF TANKS	B-2
TABLE B-2.	INCREMENTAL COST-EFFECTIVENESS BETWEEN EACH CONTROL OPTION FOR FIXED-ROOF TANKS	B-3
TABLE B-3.	INCREMENTAL COST-EFFECTIVENESS WITHIN EACH CONTROL OPTION FOR INTERNAL FLOATING ROOF TANKS	B-4
TABLE B-4.	INCREMENTAL COST-EFFECTIVENESS BETWEEN EACH CONTROL OPTION FOR INTERNAL FLOATING ROOF TANKS	B-5
TABLE B-5.	INCREMENTAL COST-EFFECTIVENESS WITHIN EACH CONTROL OPTION FOR EXTERNAL FLOATING ROOF TANKS	B-6

1.0 INTRODUCTION

The purpose of this document is to provide information on alternative control techniques (ACT) for volatile organic compound (VOC) emissions from the storage of volatile organic liquids. The control techniques described in this document are applicable to storage tanks in all industries; however, most tanks described in this document are located at petroleum refineries, chemical plants, pipelines, and liquid terminals.

This document contains information on emissions, controls, control options, and costs that States can use in developing rules based on reasonably available control technology (RACT). The document presents options only, and does not contain a recommendation on RACT.

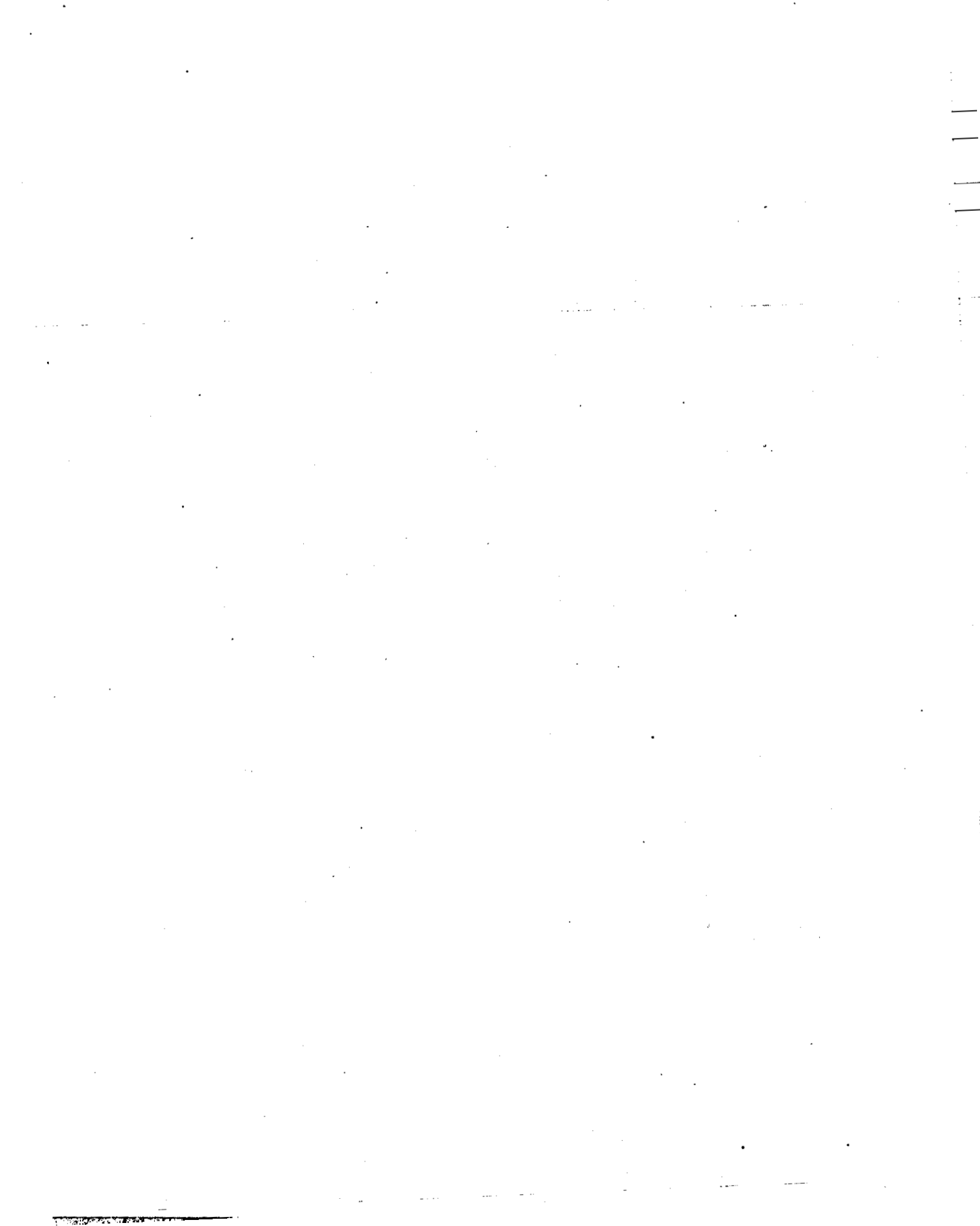

2.0 STORAGE TANK DESCRIPTIONS

2.1 INTRODUCTION

This chapter presents basic descriptions of fixed-roof tanks, internal and external floating roof tanks, and horizontal tanks. In addition, the chapter provides descriptions of perimeter seals and fittings for both internal and external floating roofs.

2.2 TYPES OF STORAGE TANKS

Three types of vessels are of concern in examining control techniques for volatile organic liquid (VOL) storage vessels:

1. Fixed-roof tanks;
2. External floating roof tanks; and
3. Internal floating roof tanks.

These tanks are cylindrical in shape with the axis oriented perpendicular to the foundation. The tanks are almost exclusively above ground, although below-ground vessels and horizontal vessels (i.e., with the axis parallel to the foundation) also can be used in VOL service. Controls that apply to horizontal tanks primarily are limited to vapor recovery systems as discussed in Chapter 4. Vapor recovery systems are capable of collecting and processing VOC vapors and gases discharged from the storage vessel so as to reduce their emission to the atmosphere.

2.2.1 Fixed-Roof Tanks

Of currently used tank designs, the fixed-roof tank is the least expensive to construct and is generally considered the minimum acceptable equipment for storing VOL's. A typical fixed-roof tank, which is shown in Figure 2-1, consists of a cylindrical steel shell with a cone- or dome-shaped roof that is

permanently affixed to the tank shell. Most recently built tanks are of all-welded construction and are designed to be both liquid- and vapor-tight. However, older tanks may be of riveted or bolted construction and may not be vapor-tight. A breather valve (pressure-vacuum valve), which is commonly installed on many fixed-roof tanks, allows the tank to operate at a slight internal pressure or vacuum. Breather vents are typically set at 0.19 kiloPascals (kPa) (0.75 inches of water column [in. w.c.]) on atmospheric pressure fixed-roof tanks.¹ Because this valve prevents the release of vapors during only very small changes in temperature, barometric pressure, or liquid level, the emissions from a fixed-roof tank can be appreciable. Additionally, gauge hatches/sample wells, float gauges, and roof manholes provide accessibility to these tanks and also serve as potential sources of volatile emissions.

2.2.2 External Floating Roof Tanks

Floating roofs are constructed of welded steel plates and are of three general types: pan, pontoon, and double deck. Although numerous pan-type floating roofs are currently in use, the present trend is toward pontoon and double-deck floating roofs.² These two most common types of external floating-roof tanks are shown in Figures 2-2 and 2-3. Manufacturers supply various versions of these basic types of floating roofs, which are tailored to emphasize particular features, such as full liquid contact, load-carrying capacity, roof stability, or pontoon arrangement.² An external floating roof tank consists of a cylindrical steel shell equipped with a deck or roof that floats on the surface of the stored liquid, rising and falling with the liquid level. The liquid surface is completely covered by the floating roof except in the small annular space between the roof and the shell. A seal attached to the roof slides against the tank wall as the roof is raised or lowered.

2.2.3 Internal Floating Roof Tanks

There are two basic types of internal floating roof tanks: tanks in which the fixed roof is supported by vertical columns within the tank; and tanks with a self-supporting fixed roof and

no internal support columns. The fixed roof is not necessarily free of openings but does span the entire open plan area of the vessel. Fixed roof tanks that have been retrofitted to employ an internal floating roof are typically of the first type, while external floating roof tanks that have been converted to an internal floating roof tank typically have a self-supporting roof. Tanks initially constructed with both a fixed roof and an internal floating roof may be of either type. An internal floating roof tank has both a permanently affixed roof and a roof that floats inside the tank on the liquid surface (contact roof) or is supported on pontoons several inches above the liquid surface (noncontact roof). The internal floating roof rises and falls with the liquid level. Typical contact and noncontact internal floating roof tanks are shown in Figures 2-4a and 2-4b, respectively.

Contact-type roofs include (1) aluminum sandwich panel roofs with a honeycombed aluminum core floating in contact with the liquid; (2) resin-coated, fiberglass-reinforced polyester (FRP), buoyant panels floating in contact with the liquid; and (3) pan-type steel roofs, floating in contact with the liquid with or without the aid of pontoons. The majority of contact internal floating roofs currently in VOL service are pan-type steel or aluminum sandwich panel type. The FRP roofs are less common.

Several variations of the pan-type contact steel roof exist. The design may include bulkheads or open compartments around the perimeter of the roof so that any liquid that may leak or spill onto the deck is contained. Alternatively, the bulkheads may be covered to form sealed compartments (i.e., pontoons), or the entire pan may be covered to form a sealed, double-deck, steel floating roof. Generally, construction is of welded steel.

Noncontact-type roofs typically consist of an aluminum deck laid on an aluminum grid framework supported above the liquid surface by tubular aluminum pontoons. The deck skin for the noncontact-type floating roofs is typically constructed of rolled aluminum sheets (about 1.5 meters [m] [4.9 feet (ft)] wide, 2.3 m [7.5 ft] long and 0.58 millimeter [mm] [0.023 inches (in)]

thick). The overlapping aluminum sheets are joined by bolted aluminum clamping bars that run perpendicular to the pontoons to improve the rigidity of the frame. The deck skin seams can be metal on metal or gasketed with a polymeric material. The pontoons and clamping bars form the structural frame of the floating roof. Deck seams in the noncontact internal floating roof design are a source of emissions. Aluminum sandwich panel contact-type internal floating roofs also share this design feature. The sandwich panels are joined with bolted mechanical fasteners that are similar in concept to the noncontact deck skin clamping bars. Steel pan contact internal floating roofs are constructed of welded steel sheets and therefore have no deck seams. Similarly, the resin-coated, reinforced fiberglass panel roofs have no apparent deck seams. The panels are butted and lapped with resin-impregnated fiberglass fabric strips. The significance of deck seams with respect to emissions from internal floating roof tanks is addressed in Chapter 4.

The internal floating roof physically occupies a finite volume of space that reduces the maximum liquid storage capacity of the tank. When the tank is completely full, the floating roof touches or nearly touches the fixed roof. Consequently, the effective height of the tank decreases, thus limiting the storage capacity. The reduction in the effective height varies from about 0.15 to 0.6 m (0.5 to 2 ft), depending on the type and design of the floating roof employed.

All types of internal floating roofs, like external floating roofs, commonly incorporate flexible perimeter seals or wipers that slide against the tank wall as the roof moves up and down. These seals are discussed in detail in Section 2.3.2. Circulation vents and an open vent at the top of the fixed roof are generally provided to minimize the accumulation of hydrocarbon vapors in concentrations approaching the flammable range.

Flame arrestors are an option that can be used to protect the vessel from fire or explosion. When these are used,

circulation vents are not provided. Tank venting occurs through a pressure-vacuum vent and flame arrestor.

2.2.4 Horizontal Tanks

Horizontal tanks are constructed for both above-ground and underground service. Figures 2-5 and 2-6 present schematics of typical underground and above-ground horizontal tanks. Horizontal tanks are usually constructed of steel, steel with a fiberglass overlay, or fiberglass-reinforced polyester. Horizontal tanks are generally small storage tanks with capacities of less than 75,710 liters (L) (20,000 gallons [gal]). Horizontal tanks are constructed such that the length of the tank is not greater than six times the diameter to ensure structural integrity. Horizontal tanks are usually equipped with pressure-vacuum vents, gauge hatches and sample wells, and manholes to provide accessibility to these tanks. In addition, underground tanks are cathodically protected to prevent corrosion of the tank shell. Cathodic protection is accomplished by placing sacrificial anodes in the tank that are connected to an impressed current system or by using galvanic anodes in the tank.

The potential emission sources for above-ground horizontal tanks are the same as those for fixed-roof tanks. Emissions from underground storage tanks are mainly associated with changes in the liquid level in the tank. Losses due to changes in temperature or barometric pressure are minimal for underground tanks because the surrounding earth limits the diurnal temperature change and changes in the barometric pressure would result in only small losses.

2.3 TYPES OF FLOATING ROOF PERIMETER SEALS

2.3.1 External Floating Roof Seals

Regardless of tank design, a floating roof requires a device to seal the gap between the tank wall and the roof perimeter. A seal, or in the case of a two-seal system, the lower (primary) seal, can be made from various materials suitable for organic liquids service. The basic designs available for external floating roof seals are (1) mechanical (metallic) shoe seals, (2) liquid-filled seals, and (3) (vapor- or liquid-mounted)

resilient foam-filled seals. Figure 2-7 depicts these three general types of seals.

One major difference in seal system design is the way in which the seal is mounted with respect to the liquid. Figure 2-7c shows a vapor space between the liquid surface and seal, whereas in Figures 2-7a and 2-7d, the seals rest on the liquid surface. These liquid-filled and resilient foam-filled seals are classified as liquid- or vapor-mounted seals, depending on their location. Mechanical shoe seals are different in design from liquid-filled or resilient foam-filled seals and cannot be characterized as liquid- or vapor-mounted. However, because the shoe and envelope combination precludes contact between the annular vapor space above the liquid and the atmosphere (see Figure 2-7b), the emission rate of a mechanical shoe seal is closer to that of a liquid-mounted seal than that of a vapor-mounted seal.

2.3.1.1 Mechanical Shoe Seal. A mechanical shoe seal, otherwise known as a "metallic shoe seal" (Figure 2-7b), is characterized by a metallic sheet (the "shoe") that is held against the vertical tank wall. Prior to 40 CFR 60 Subpart Ka, the regulations did not specify a height for mechanical shoe seals, however, shoe heights typically range from 75 to 130 centimeters (cm) (30 to 51 in). The shoe is connected by braces to the floating roof and is held tightly against the wall by springs or weighted levers. A flexible coated fabric (the "envelope") is suspended from the shoe seal to the floating roof to form a vapor barrier over the annular space between the roof and the primary seal.

2.3.1.2 Liquid-Filled Seal. A liquid-filled seal (Figure 2-7a) may consist of a tough fabric band or envelope filled with a liquid, or it may consist of a flexible polymeric tube 20 to 25 cm (8 to 10 in) in diameter filled with a liquid and sheathed with a tough fabric scuff band. The liquid is commonly a petroleum distillate or other liquid that will not contaminate the stored product if the tube ruptures.

Liquid-filled seals are mounted on the product liquid surface with no vapor space below the seal.

2.3.1.3 Resilient Foam-Filled Seal. A resilient foam-filled seal is similar to a liquid-filled seal except that a resilient foam log is used in place of the liquid. The resiliency of the foam log permits the seal to adapt itself to minor imperfections in tank dimensions and in the tank shell. The foam log may be mounted above the liquid surface (vapor-mounted) or on the liquid surface (liquid-mounted). Typical vapor-mounted and liquid-mounted seals are presented in Figures 2-7c and 2-7d, respectively.

2.3.1.4 Secondary Seals on External Floating Roofs. A secondary seal on an external floating roof consists of a continuous seal mounted on the rim of the floating roof and extending to the tank wall, covering the entire primary seal. Secondary seals are normally constructed of flexible polymeric materials. Figure 2-8 depicts several primary and secondary seal systems. An alternative secondary seal design incorporates a steel leaf to bridge the gap between the roof and the tank wall. The leaf acts as a compression plate to hold a polymeric wiper against the tank wall.

A rim-mounted secondary seal installed over a primary seal provides a barrier for volatile organic compound (VOC) emissions that escape from the small vapor space between the primary seal and the wall and through any openings or tears in the seal envelope of a metallic shoe seal (Figure 2-8). Although not shown in Figure 2-8, a secondary seal can be used in conjunction with a weather shield as described in the following section.

Another type of secondary seal is a shoe-mounted secondary seal. A shoe-mounted seal extends from the top of the shoe to the tank wall (Figure 2-9). These seals do not provide protection against VOC leakage through the envelope. Holes, gaps, tears, or other defects in the envelope can permit direct exchange between the saturated vapor under the envelope and the atmosphere. Wind can enter this space through envelope defects,

flow around the circumference of the tank, and exit saturated or nearly saturated with VOC vapors.

2.3.1.5 Weather Shield. A weather shield (Figures 2-7a, 2-7c, and 2-7d) may be installed over the primary seal to protect it from deterioration caused by debris and exposure to the elements. Though the NSPS's 40 CFR 60 Subparts Ka and Kb do not accept the installation of a weather shield as equivalent to a secondary seal, there are a large number of existing tanks not affected by the NSPS that have this configuration. Typically, a weather shield is an arrangement of overlapping thin metal sheets pivoted from the floating roof to ride against the tank wall. The weather shield, by the nature of its design, is not an effective vapor barrier. For this reason, it differs from the secondary seal. Although the two devices are conceptually similar in design, they are designed for and serve different purposes.

2.3.2 Internal Floating Roof Seals

Internal floating roofs typically incorporate one of two types of flexible, product-resistant seals: resilient foam-filled seals or wiper seals. Similar to those employed on external floating roofs, each of these seals closes the annular vapor space between the edge of the floating roof and the tank shell to reduce evaporative losses. They are designed to compensate for small irregularities in the tank shell and allow the roof to freely move up and down in the tank without binding.

2.3.2.1 Resilient Foam-Filled Seal. A resilient foam-filled seal used on an internal floating roof is similar in design to that described in Section 2.3.1.3 for external floating roofs. Two types of resilient foam-filled seals for internal floating roofs are shown in Figures 2-10a and 2-10b. These seals can be mounted either in contact with the liquid surface (liquid-mounted) or several centimeters above the liquid surface (vapor-mounted).

Resilient foam-filled seals work because of the expansion and contraction of a resilient material to maintain contact with the tank shell while accommodating varying annular rim space

widths. These seals consist of a core of open-cell foam encapsulated in a coated fabric. The elasticity of the foam core pushes the fabric into contact with the tank shell. The seals are attached to a mounting on the deck perimeter and are continuous around the roof circumference. Polyurethane-coated nylon fabric and polyurethane foam are commonly used materials. For emission control, it is important that the mounting and radial seal joints be vapor-tight and that the seal be in substantial contact with the tank shell.⁵

2.3.2.2 Wiper Seals. Wiper seals are commonly used as primary seals for internal floating roof tanks. This type of seal is depicted in Figure 2-10c.

Wiper seals generally consist of a continuous annular blade of flexible material fastened to a mounting bracket on the deck perimeter that spans the annular rim space and contacts the tank shell. The mounting is such that the blade is flexed, and its elasticity provides a sealing pressure against the tank shell. Such seals are vapor-mounted; a vapor space exists between the liquid stock and the bottom of the seal. For emission control, it is important that the mounting be vapor-tight, that the seal be continuous around the circumference of the roof, and that the blade be in substantial contact with the tank shell.⁵

Three types of materials are commonly used to make the wipers. One type consists of a cellular, elastomeric material tapered in cross section with the thicker portion at the mounting. Buna-N rubber is a commonly used material. All radial joints in the blade are joined.⁵

A second type of wiper seal construction uses a foam core wrapped with a coated fabric. Polyurethane on nylon fabric and polyurethane foam are common materials. The core provides the flexibility and support, while the fabric provides the vapor barrier and wear surface.⁵

A third type of wiper seal consists of overlapping segments of seal material (shingle-type seal). Shingle-type seals differ from the wiper seals discussed previously in that they do not provide a continuous vapor barrier.

2.3.2.3 Secondary Seals for Internal Floating Roof Tanks.

Secondary seals may be used to provide some additional evaporative loss control over that achieved by the primary seal. The secondary seal is mounted to an extended vertical rim plate, above the primary seal, as shown in Figure 2-11. Secondary seals can be either a resilient foam-filled seal or an elastomeric wiper seal, as described in Sections 2.3.2.1 and 2.3.2.2, respectively. For a given roof design, using a secondary seal further limits the operating capacity of a tank due to the need to keep the seal from interfering with the fixed-roof rafters when the tank is filled. Secondary seals are not commonly used on internal floating roof tanks that are not affected by the NSPS (40 CFR 60 Subpart Kb).⁵

2.4 TYPES OF FLOATING ROOF DECK FITTINGS

2.4.1 External Floating Roof Fittings

Numerous fittings penetrate or are attached to an external floating roof. These fittings accommodate structural support members or allow for operational functions. These fittings can be a source of emissions in that they must penetrate the deck. Other accessories are used that do not penetrate the deck and are not, therefore, sources of evaporative loss. The most common fittings relevant to controlling vapor losses are described in the following sections.

2.4.1.1 Access Hatches.² An access hatch consists of an opening in the deck with a peripheral vertical well attached to the deck and a removable cover to close the opening as shown in Figure 2-12. An access hatch is typically sized to allow workers and materials to pass through the deck for construction or servicing. The cover can rest directly on the well, or a gasketed connection can be used to reduce evaporative loss. Bolting the cover to the well reduces losses further.

2.4.1.2 Slotted and Unslotted Guide-Pole Wells/Sample Wells.² Antirotation devices are used to prevent floating roofs from rotating and potentially damaging roof equipment and seal systems. A commonly used antirotation device is a guide pole that is fixed at the top and bottom of the tank (Figures 2-13a

and 2-13b). The guide pole passes through a well on the deck. Rollers attached to the top of the well ride on the outside surface of the guide pole to prevent the floating roof from rotating. The guide pole well has a sliding cover to accommodate limited radial movement of the roof. The sliding cover can be equipped with a gasket between the guide pole and the cover to reduce evaporative loss. The guide pole well can also be equipped with a gasket between the sliding cover and the top of the well to reduce evaporative loss. Openings at the top and bottom of the guide pole provide a means of hand-gauging the tank level and of taking bottom samples. In the slotted guide pole/sample well application, the well of the guide pole is constructed with a series of holes or slots that allow the product to mix freely in the guide pole and thus have the same composition and liquid level as the product in the tank. To reduce evaporative loss caused by these openings, a removable float is sometimes placed inside the guide pole.

2.4.1.3 Gauge Float Wells.² Gauge floats are used to indicate the level of stock within the tank. These usually consist of a float residing within a well that passes through the floating deck, as shown in Figure 2-14a. The float is connected to an indicator on the exterior of the tank via a tape passing through a guide system. The float rests on the stock surface within the well, which is enclosed by a sliding cover. A cable attaches to the float and passes through a hole located at the center of the cover. As with similar deck penetrations, the well extends into the liquid stock on noncontact floating decks. Evaporation loss can be reduced by gasketing and/or bolting the connection between the cover and the rim of the well.

2.4.1.4 Gauge Hatch/Sample Wells.² Gauge hatch/sample wells provide access for hand-gauging the level of stock in the tank and for taking thief samples of the tank contents. A gauge hatch/sample well consists of a pipe sleeve through the deck and a self-closing gasketed cover, as shown in Figure 2-14b. Gauge hatch/sample wells are usually located under the gauger's platform, which is mounted on the top of the tank shell. The

cover may have a cord attached so that it can be opened from the gauger's platform. A gasketed cover reduces evaporative losses.

2.4.1.5 Vacuum Breakers.² The purpose of a vacuum breaker is to allow for the exchange of vapor and air through the internal floating roof tank during filling and emptying. Vacuum breakers are designed to be activated by changes in pressure or liquid level, or strictly by mechanical means.

Mechanical vacuum breakers are activated when the external floating deck is either being landed on its legs or floated off its legs to equalize the pressure of the vapor space across the deck. This is accomplished by opening a deck penetration that usually consists of a well formed of pipe or framing on which rests a cover (Figure 2-15). Attached to the underside of the cover is a guide leg long enough to contact the tank bottom as the external floating deck approaches the tank bottom. When in contact with the tank bottom, the guide leg mechanically opens the breaker by lifting the cover off the well. When the leg is not contacting the bottom, the penetration is closed by the cover resting on the well. The closure may or may not have a gasket between the cover and neck. Since the purpose of the vacuum breaker is to allow the free exchange of air and/or vapor, the well does not extend appreciably below the deck. The gasket on the underside of the cover, or conversely on the upper rim of the well, provides a small measure of emission control during periods when the roof is free floating and the breaker is closed.

2.4.1.6 Roof Drains.² Roof drains permit removal of rainwater from the surface of floating roofs. Two types of floating roof drainage systems are currently used: closed and open. Closed drainage systems carry rainwater from the surface of the floating roof to the outside of the tank through a flexible or articulated piping system or through a flexible hose system located below the deck in the product space. Since product does not enter this closed drainage system, there is no associated evaporative loss. Open drainage systems, consisting of an open pipe that extends a short distance below the bottom of the deck, permit rainwater to drain from the surface of the

floating roof into the product. Since these drainpipes are filled with product to the product level in the tank, evaporative loss occurs from the top of the drainpipes. Open drainage systems are commonly used on double-deck and pontoon floating roofs. Two types of roof drains are commonly used in open drainage systems: flush drains and overflow drains. Flush drains have a drain opening that is flush with the top surface of the double deck. They permit rainwater to drain into the product. Overflow drains (Figure 2-16a) consist of a drain opening that is elevated above the top surface of the floating roof, thereby limiting the maximum amount of rainwater that can accumulate on the floating roof and providing emergency drainage of rainwater. They are normally used in conjunction with a closed drainage system. Some open-roof drains are equipped with an insert to reduce the evaporative loss.

2.4.1.7 Roof Legs.² To prevent damage to fittings underneath the deck and to allow for tank cleaning or repair, supports are provided to hold the deck at a predetermined distance off the tank bottom. These supports consist of adjustable or fixed legs attached to the floating deck as shown in Figure 2-16b. For adjustable legs, the load-carrying element passes through a well or sleeve in the deck.

2.4.1.8 Rim Vents.² Rim vents are normally supplied only on tanks equipped with a mechanical shoe primary seal. The rim vent is connected to the rim vapor space by a pipe and releases any excess pressure or vacuum that is present (Figure 2-17). The rim vapor space is bounded by the floating roof rim, the primary-seal shoe, the liquid surface, and the primary-seal fabric. Rim vents usually consist of weighted pallets that rest on the gasketed surface.

2.4.2 Internal Floating Roof Fittings⁵

Numerous fittings penetrate or are attached to an internal floating roof. These fittings serve to accommodate structural support members or to allow for operational functions. The fittings can be a source of evaporative loss in that they require penetrations in the deck. Other accessories are used that do not

penetrate the deck and are not, therefore, sources of evaporative loss. The most common fittings relevant to controlling vapor losses are described in the following sections.

The access hatches, roof legs, vacuum breakers, and automatic gauge float wells for internal floating roofs are similar fittings to those described earlier for fitting control of external floating roofs.

2.4.2.1 Column Wells.⁵ The most common fixed-roof designs (Figure 2-1) are normally supported from inside the tank by means of vertical columns, which necessarily penetrate an internal floating deck. (Some fixed roofs are entirely self-supporting and, therefore, have no support columns.) Columns are made of pipe with circular cross sections or of structural shapes with irregular cross sections (built-up). The number of columns varies with tank diameter from a minimum of 1 to over 50 for very large tanks.

The columns pass through deck openings via peripheral vertical wells. With noncontact decks, the well should extend down into the liquid stock. Generally, a closure device exists between the top of the well and the column. Several proprietary designs exist for this closure, including sliding covers and fabric sleeves, which must accommodate the movements of the deck relative to the column as the liquid level changes. A sliding cover rests on the upper rim of the column well (which is normally fixed to the roof) and bridges the gap or space between the column well and the column. The cover, which has a cutout, or opening, around the column, slides vertically relative to the column as the roof raises and lowers. At the same time, the cover slides horizontally relative to the rim of the well, which is fixed to the roof. A gasket around the rim of the well reduces emissions from this fitting. A flexible fabric sleeve seal between the rim of the well and the column (with a cutout, or opening to allow vertical motion of the seal relative to the columns) similarly accommodates limited horizontal motion of the roof relative to the column. A third design combines the advantages of the flexible fabric sleeve seal with a well that

excludes all but a small portion of the liquid surface from direct exchange with the vapor space above the floating roof.

2.4.2.2 Sample Pipes or Wells.⁵ A sample well may be provided to allow liquid stock sampling. Typically, the well is funnel-shaped to allow for easy entry of a sample thief. A closure is provided, which is typically located at the lower end of the funnel and which frequently consists of a horizontal piece of fabric slit radially to allow thief entry. The well should extend into the liquid stock on noncontact decks.

Alternately, a sample well may consist of a slotted pipe extending into the liquid stock equipped with an ungasketed or gasketed sliding cover.

2.4.2.3 Ladder Wells.⁵ Some tanks are equipped with internal ladders that extend from a manhole in the fixed roof to the tank bottom. The deck opening through which the ladder passes is constructed with similar design details and considerations to those for column wells, as discussed in Section 2.4.2.2.

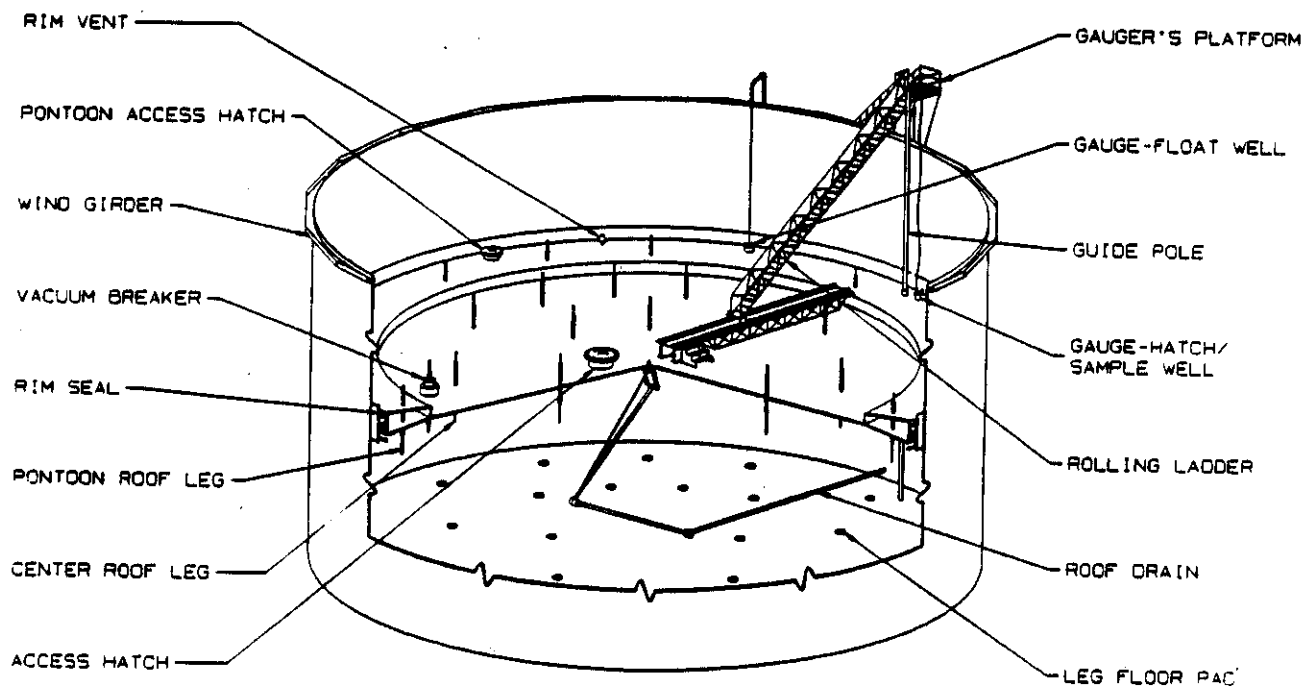

Figure 2-2. External floating roof tank (pontoon type).

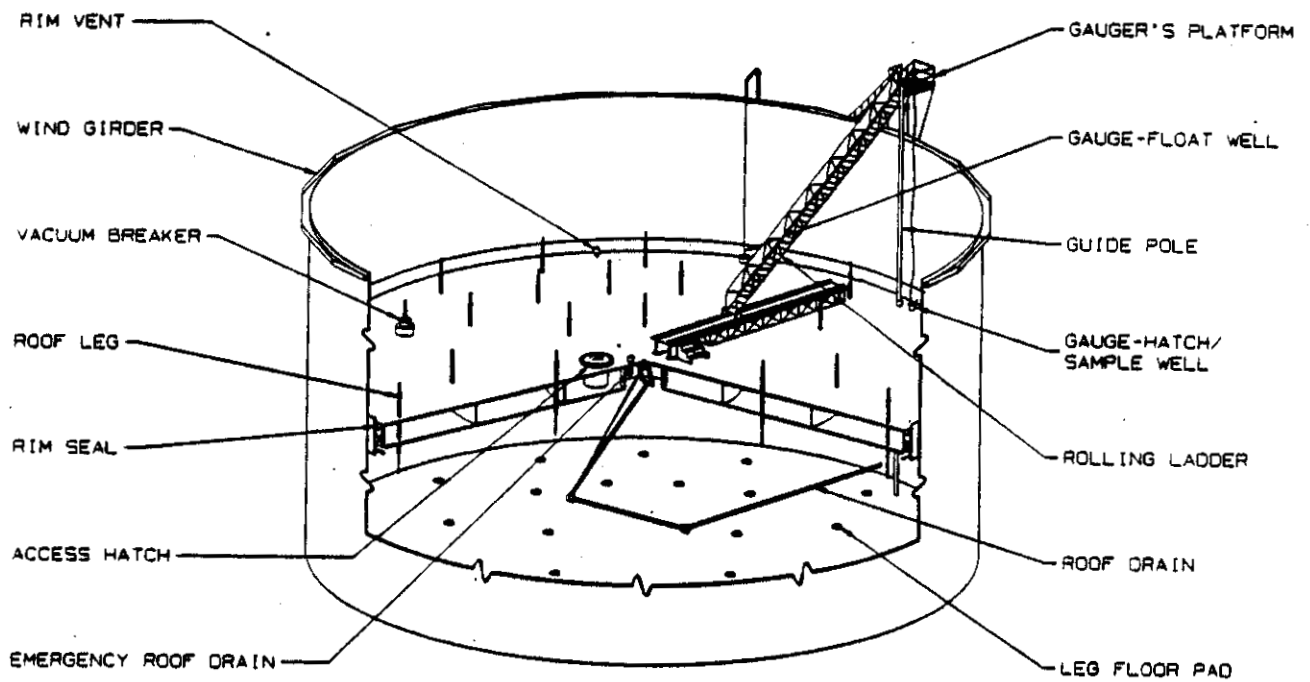
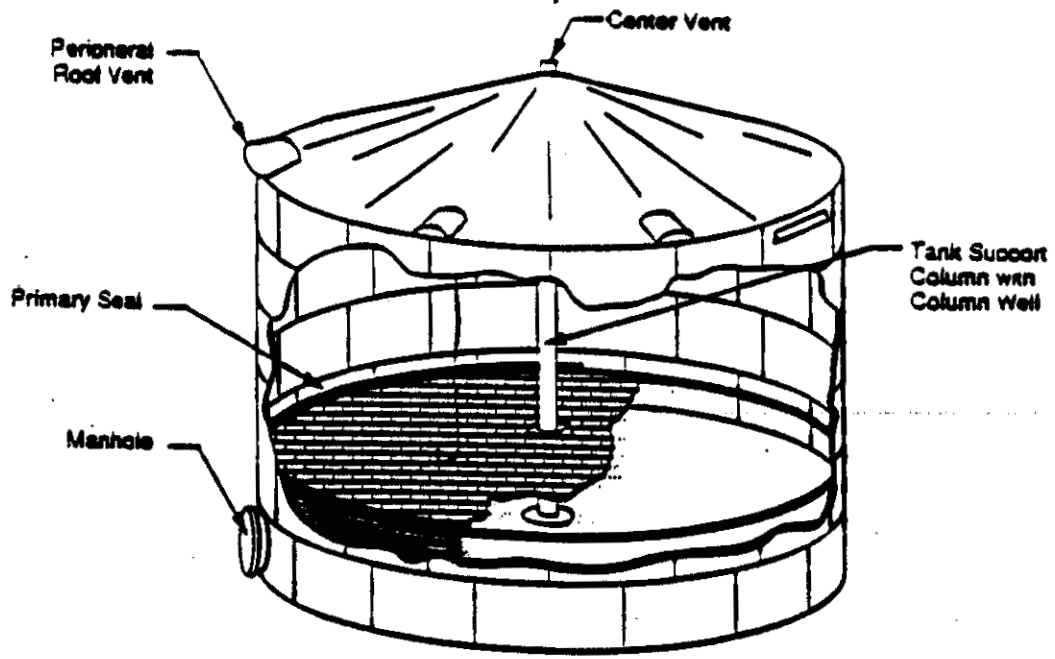
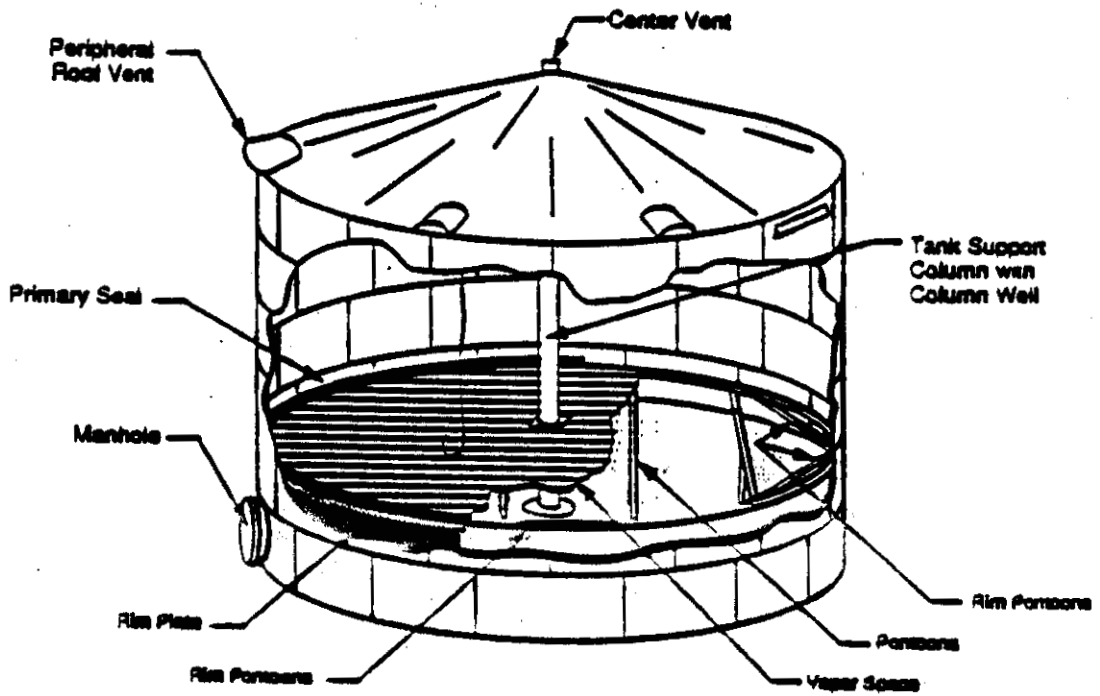

Figure 2-3. External floating roof tank (double-deck type).



a. Contact internal floating roof



b. Noncontact internal floating roof

Figure 2-4. Internal floating roof tanks.

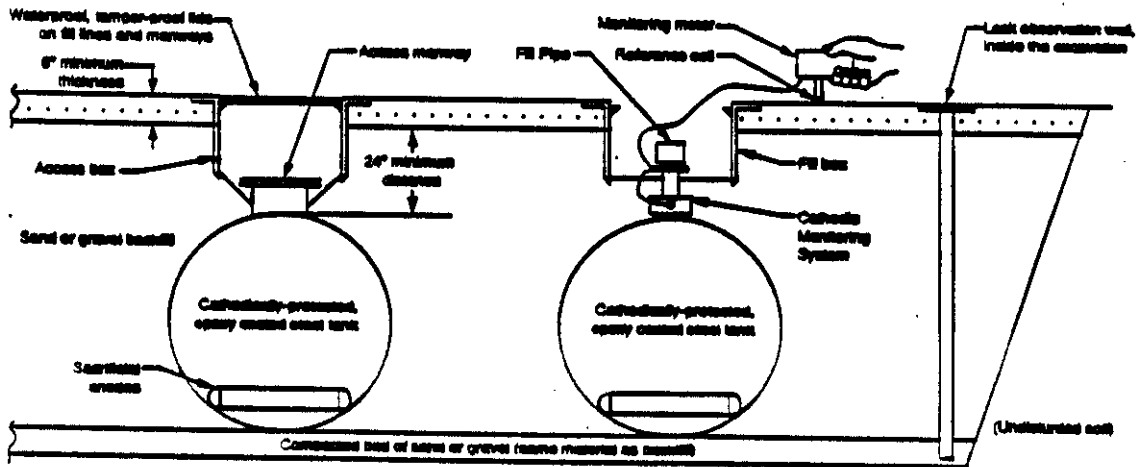
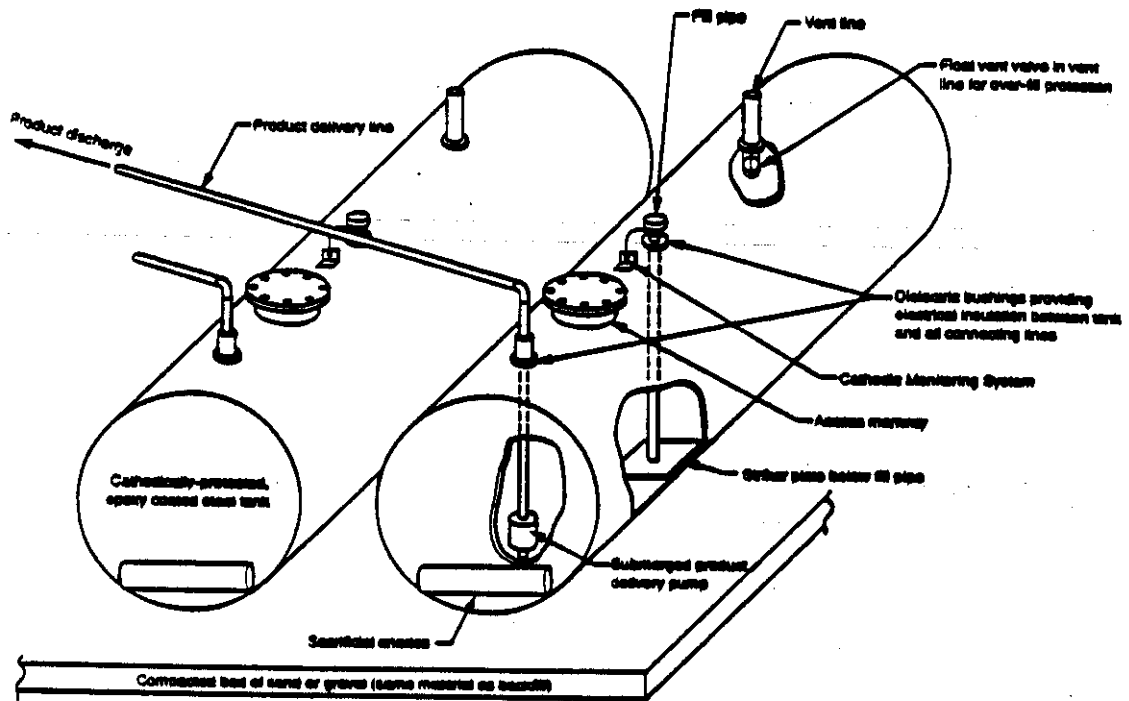

Source: Hayward Tank Mfg. Co., Number 5500 Tank Institute

Figure 2-5. Typical underground storage tank.³

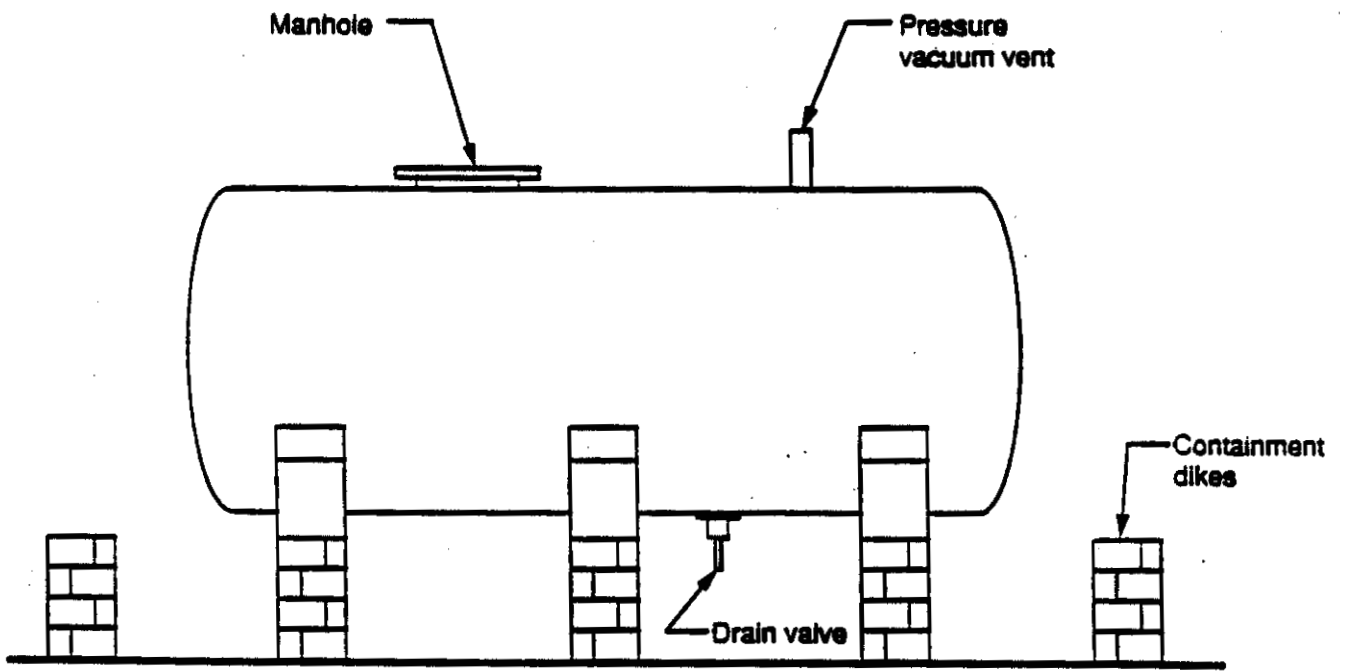

Source: Ecology and Environment, Inc., 1983.

Figure 2-6. A typical above-ground horizontal tank.⁴

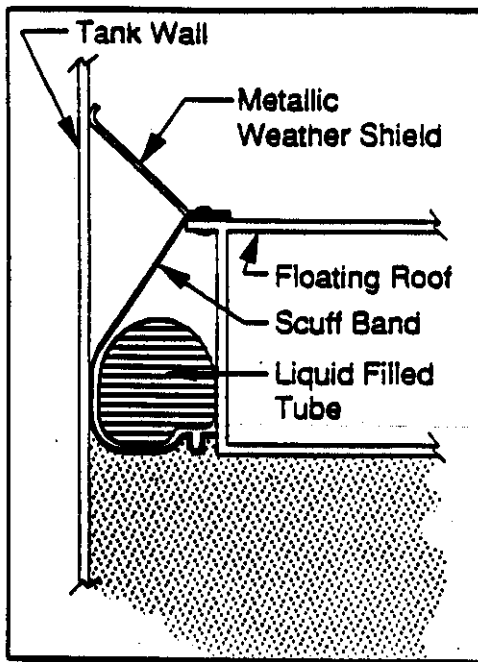

a. Liquid-filled seal with weather shield.

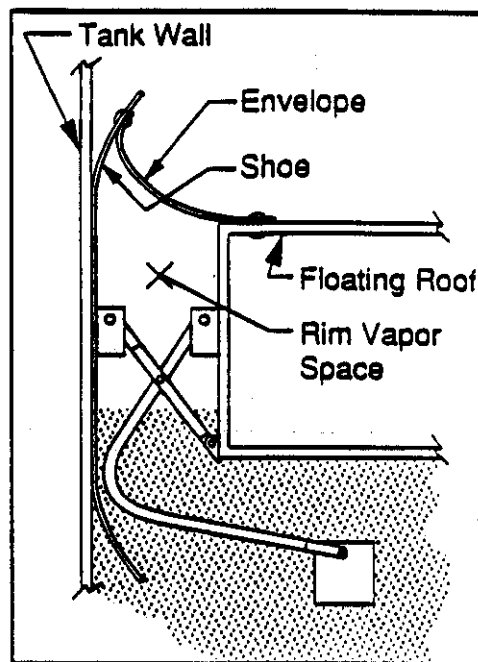

b. Metallic shoe seal.

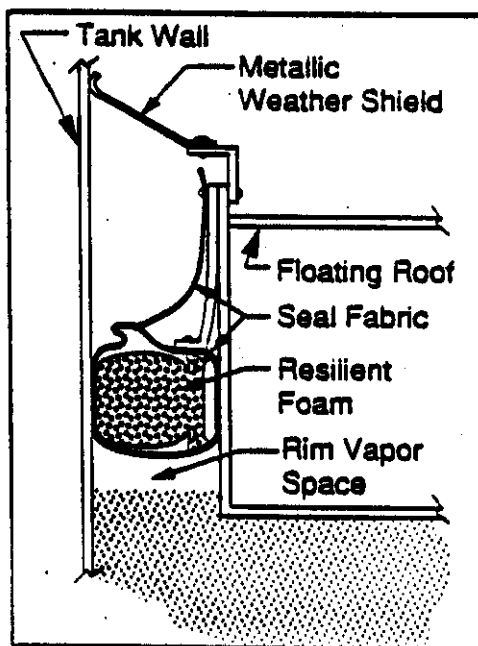

c. Vapor-mounted resilient foam-filled seal with weather shield.

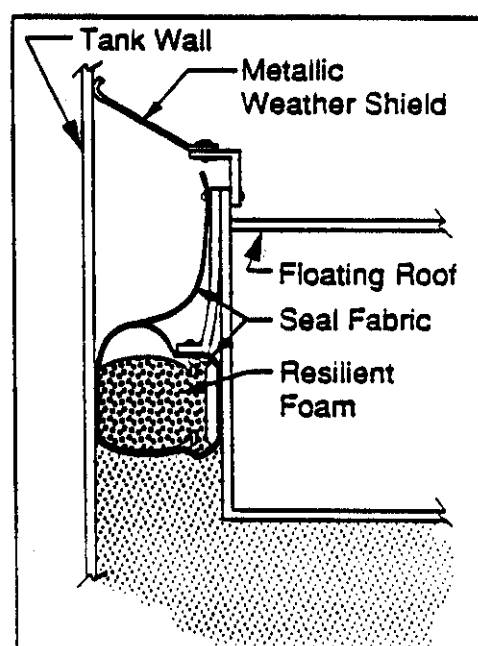

d. Liquid-mounted resilient foam-filled seal with weather shield.

Figure 2-7. Primary seals.

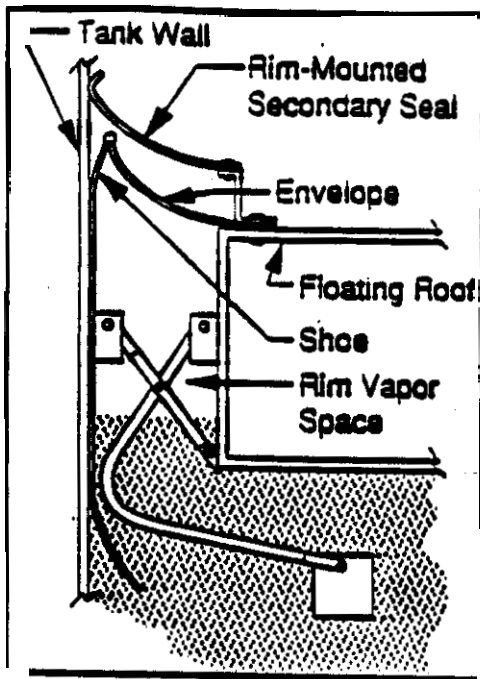

a. Shoe seal with rim-mounted secondary seal.

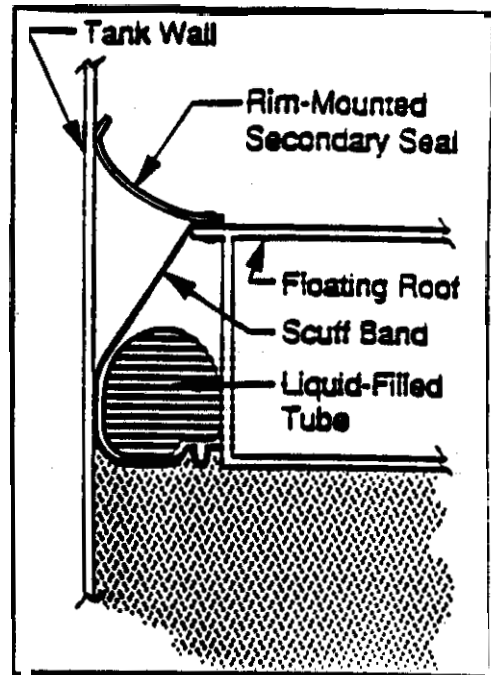

b. Liquid-filled seal with rim-mounted secondary seal.

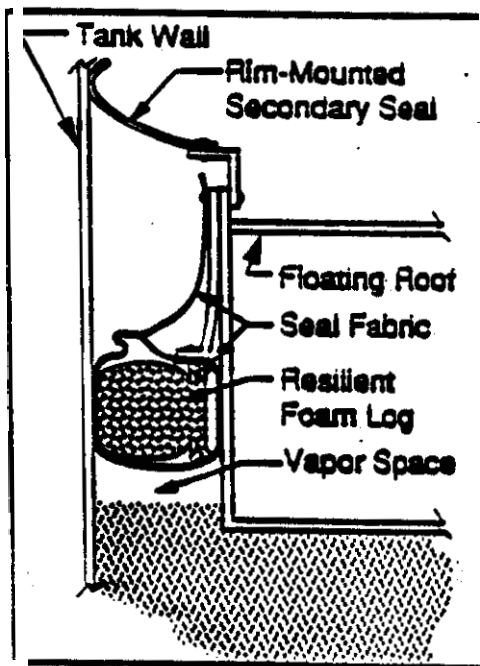

c. Resilient foam seal (vapor-mounted) with rim-mounted secondary seal.

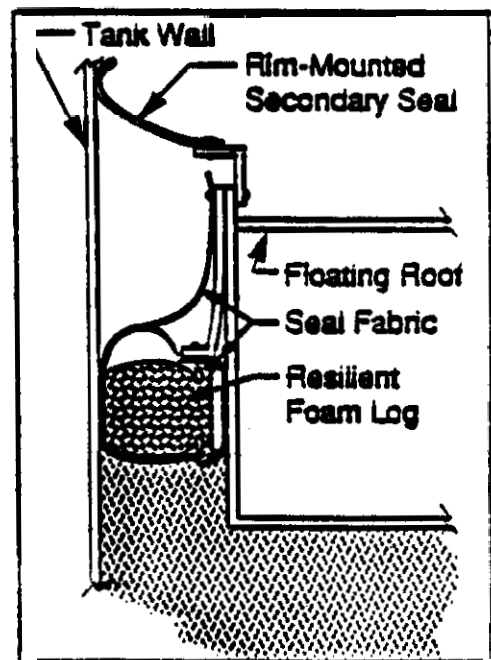

d. Resilient foam seal (liquid mounted) with rim-mounted secondary seal.

Figure 2-8 (a-d). Rim-mounted secondary seals on external floating roofs.

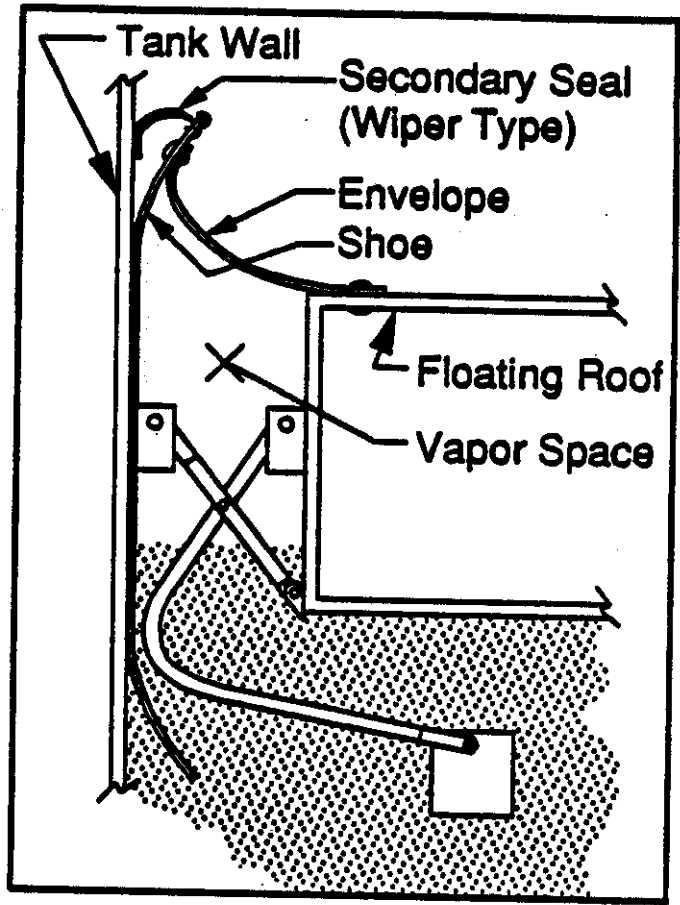
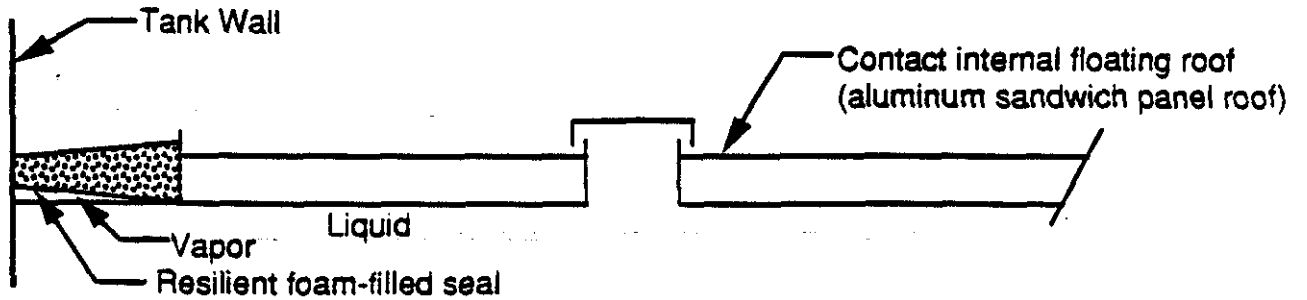
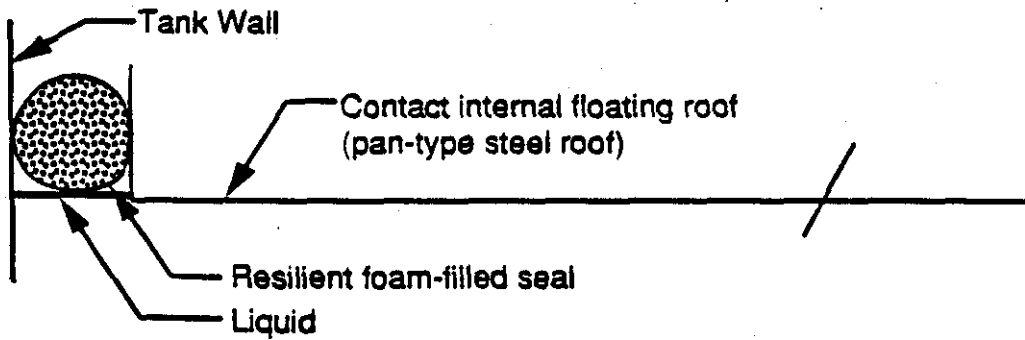

Figure 2-9. Metallic shoe seal with shoe-mounted secondary seal.

a. Resilient foam-filled seal (vapor-mounted).



b. Resilient foam-filled seal (liquid mounted).



c. Elastomeric wiper seal.

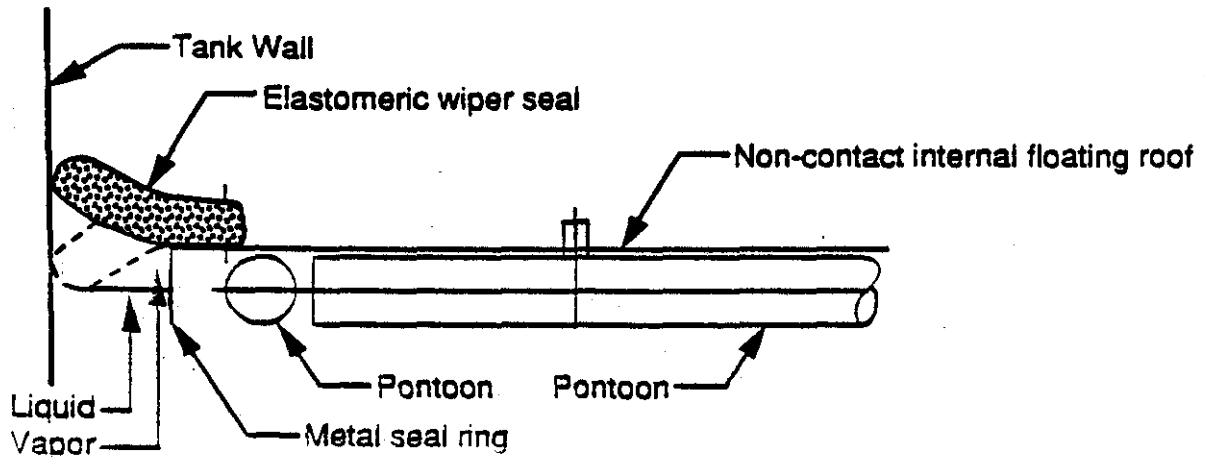

Figure 2-10. Typical flotation devices and perimeter seal for internal floating roofs.

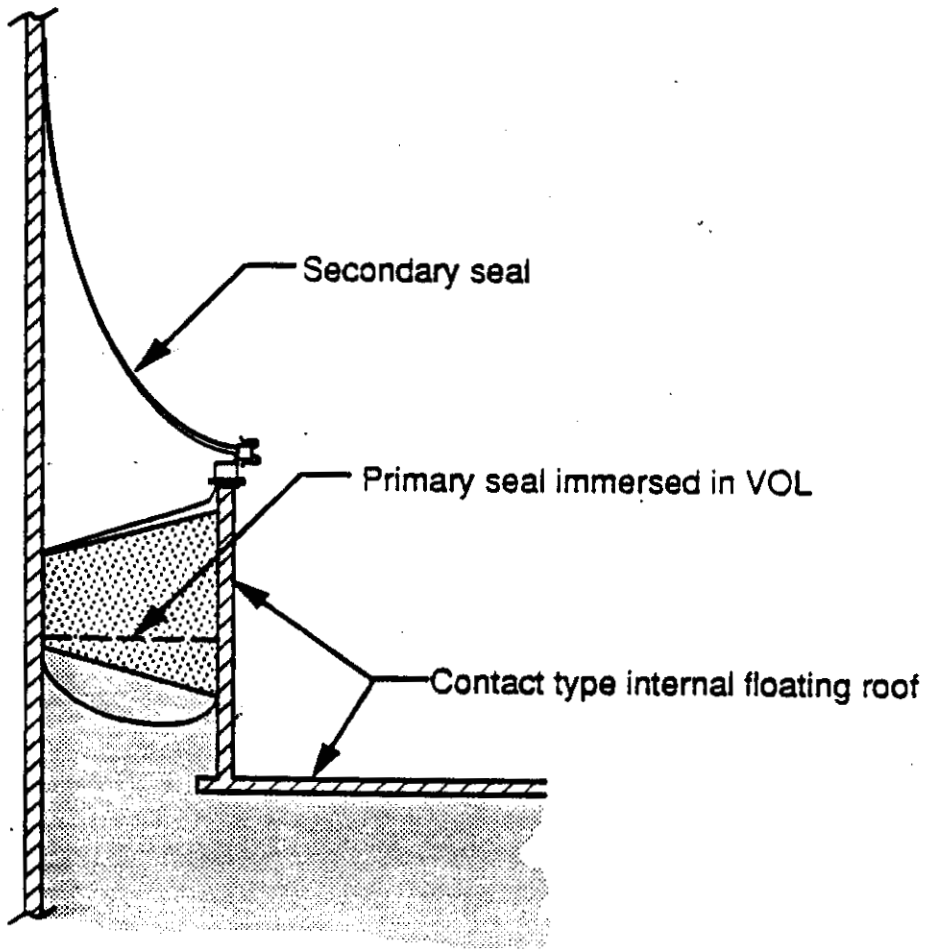

Figure 2-11. Rim-mounted secondary seal on internal floating roof.

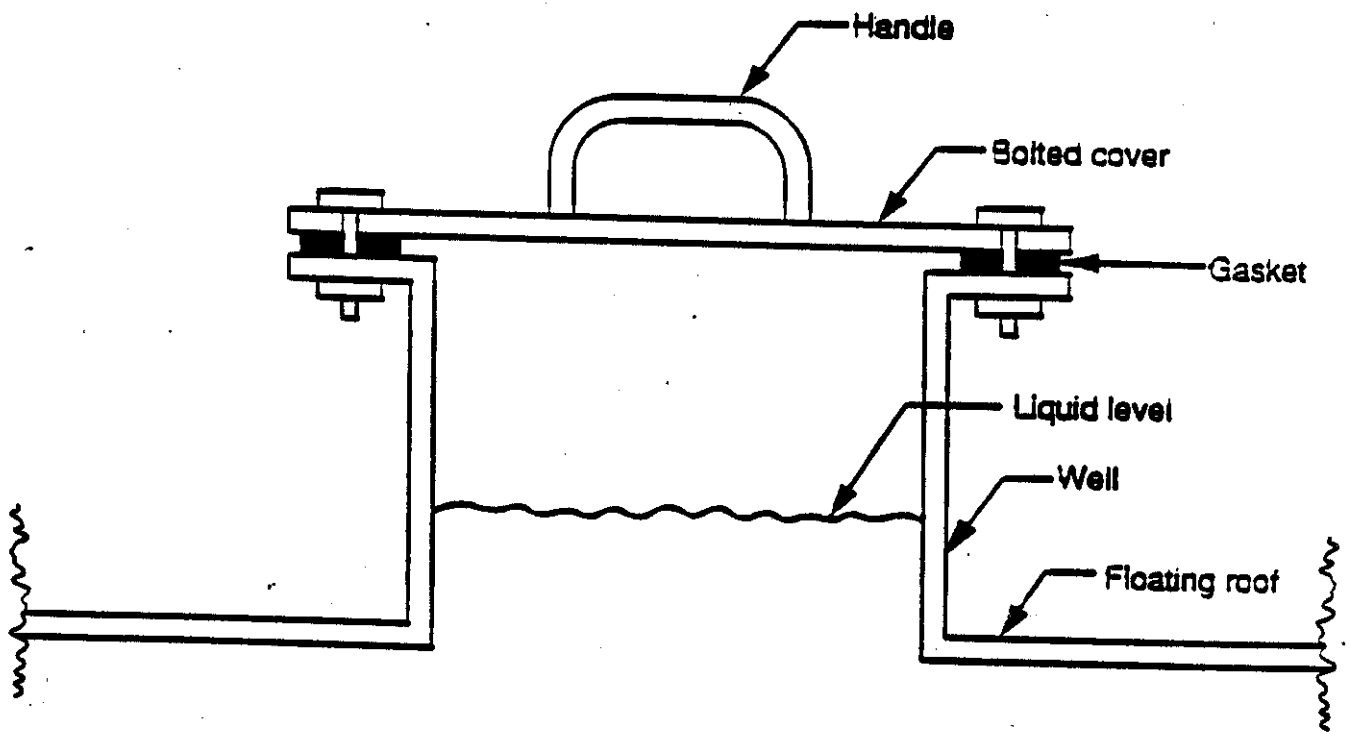

Figure 2-12. Access hatch.²

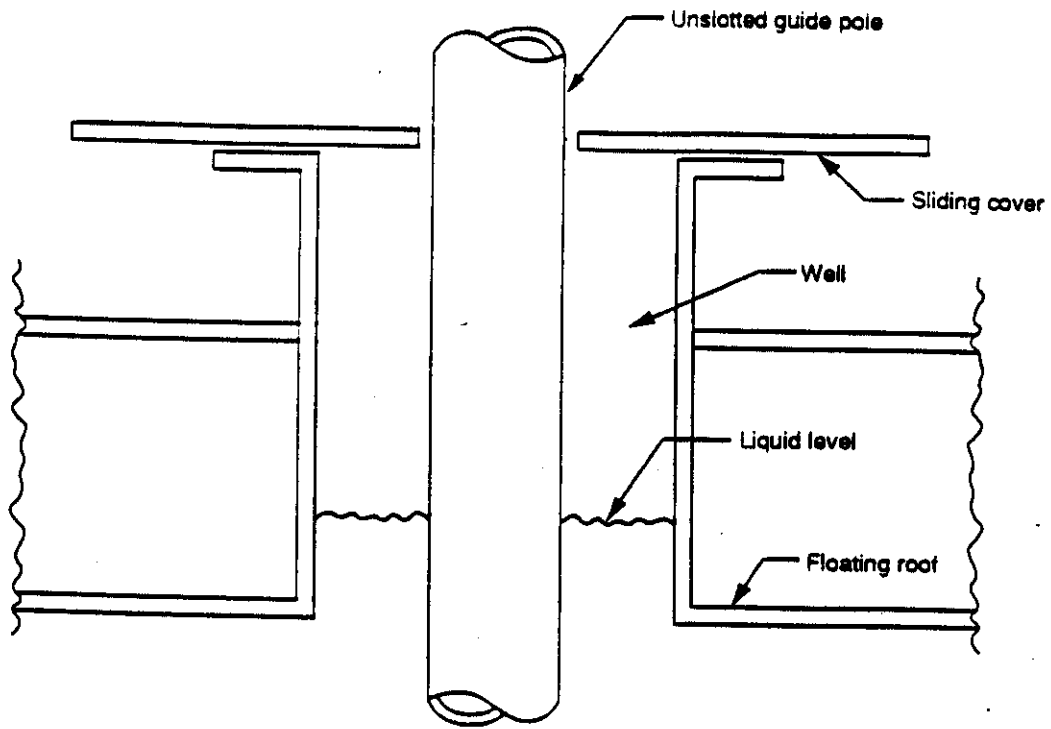

Figure 2-13a. Unslotted guide-pole well.²

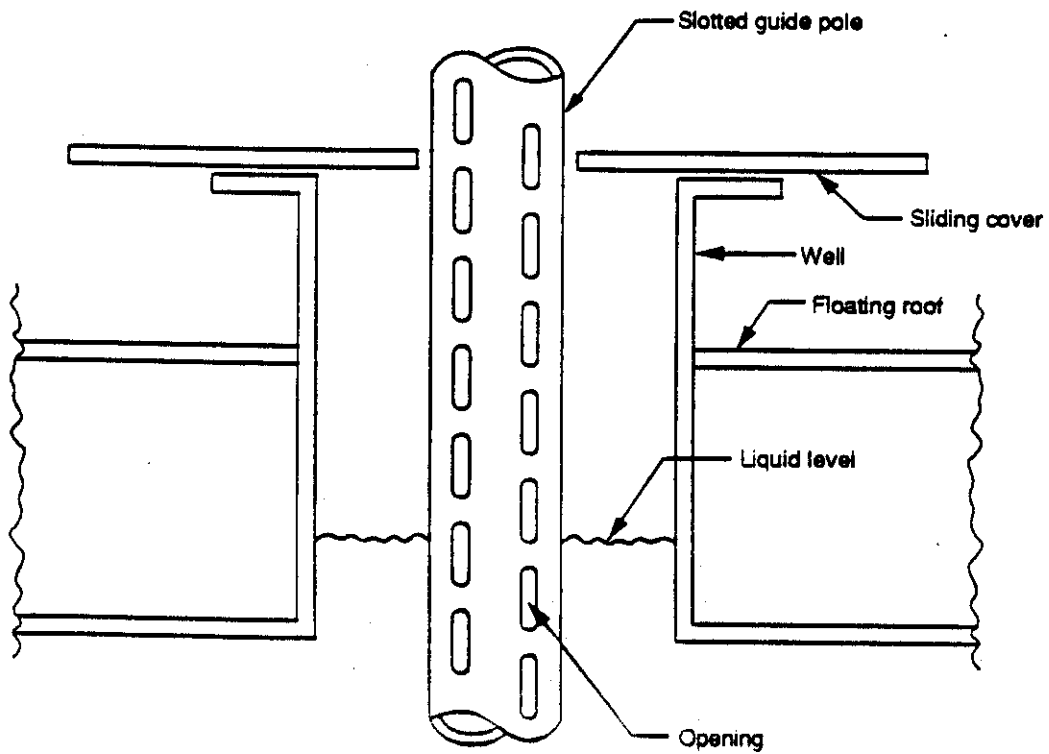

Figure 2-13b. Slotted guide-pole/sample well.²

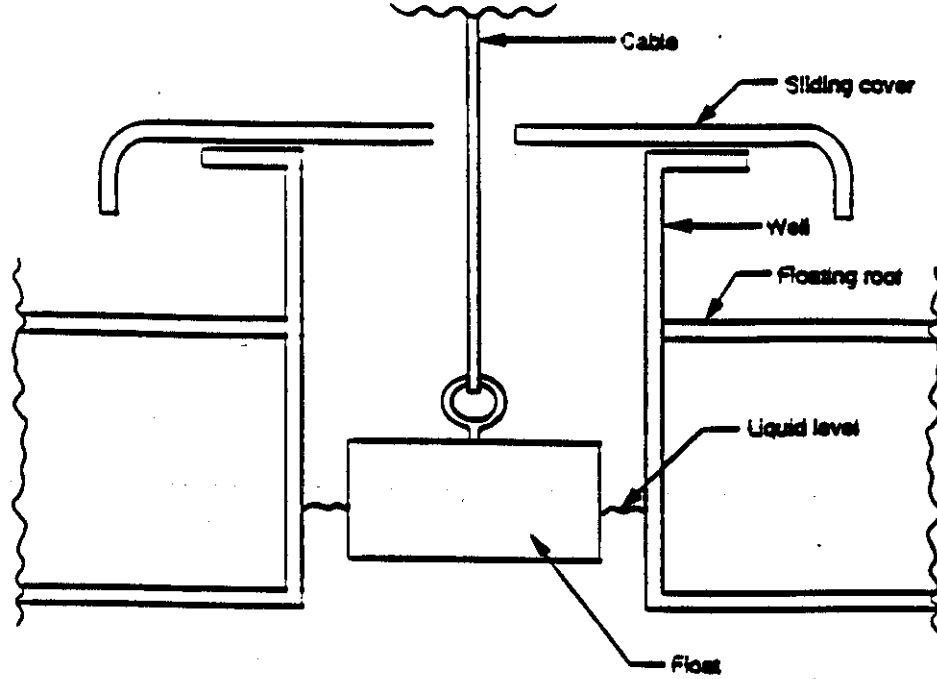

Figure 2-14a. Gauge-float well.²

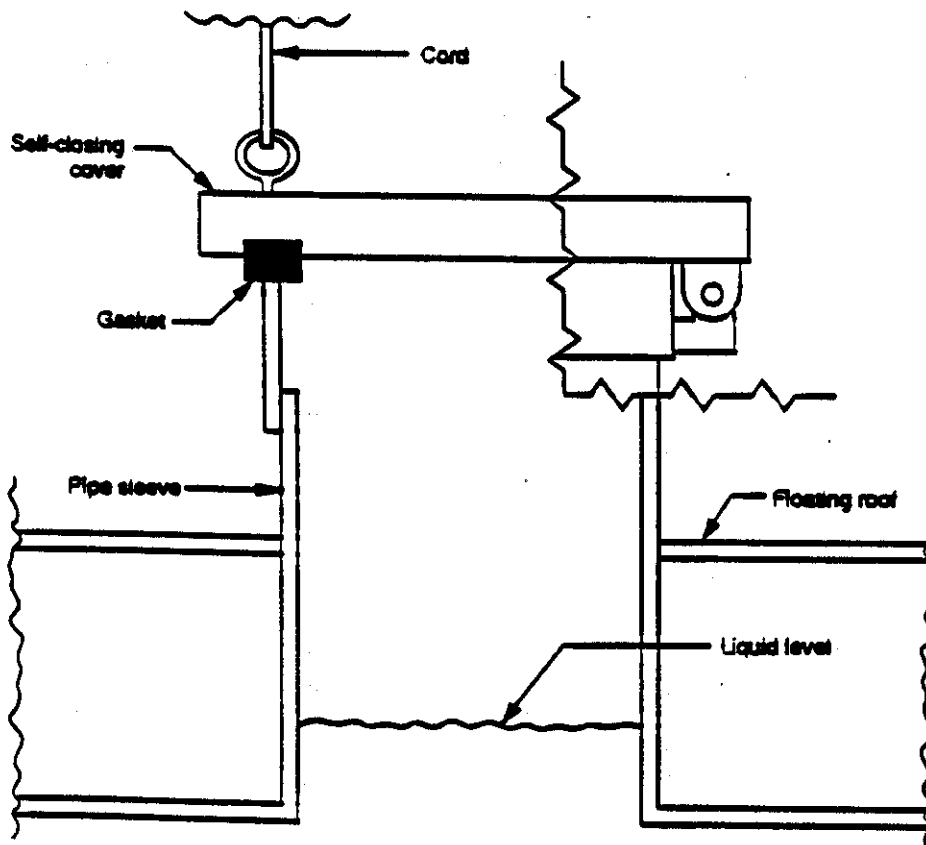

Figure 2-14b. Gauge-hatch/sample well.²

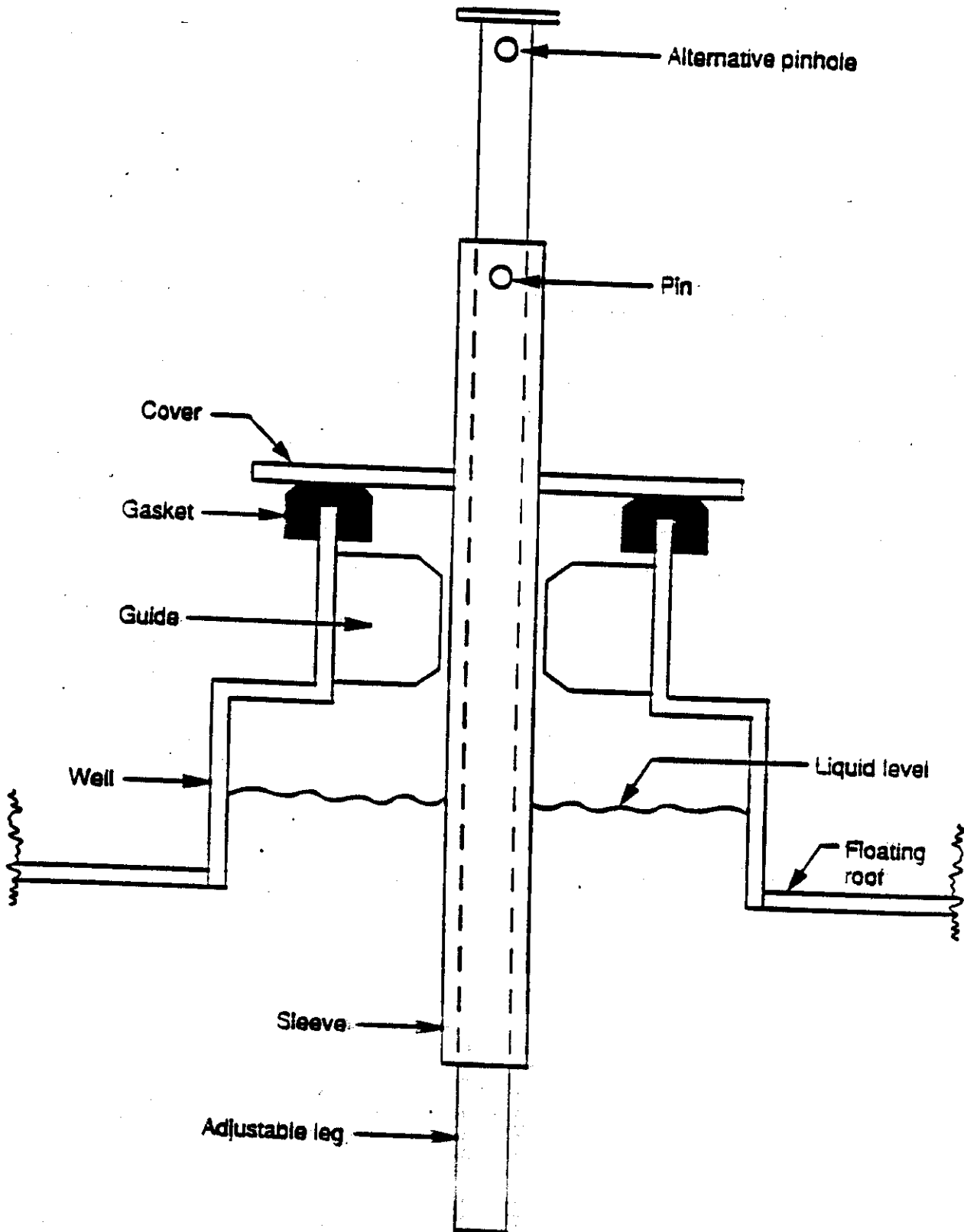

Figure 2-15. Vacuum breaker.²

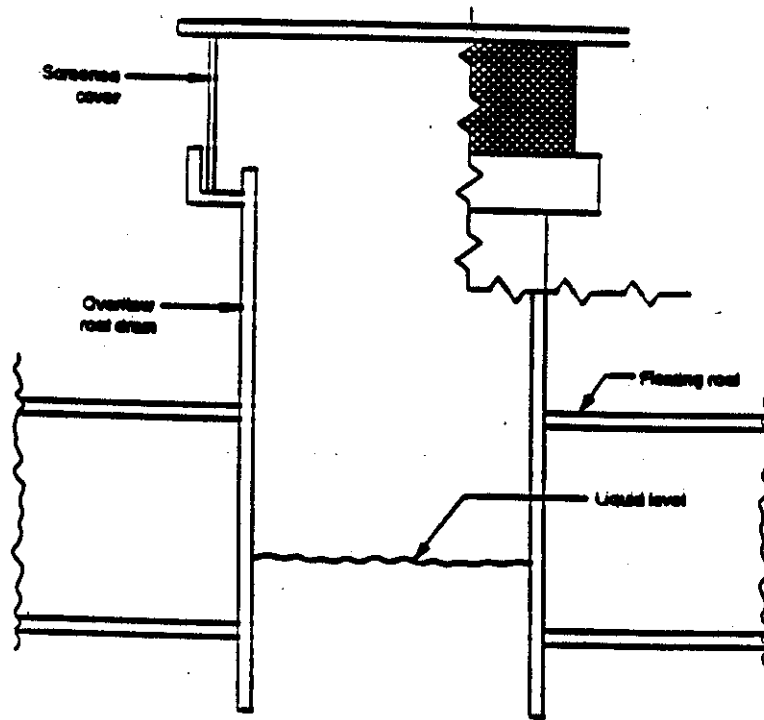

Figure 2-16a. Overflow roof drain.²

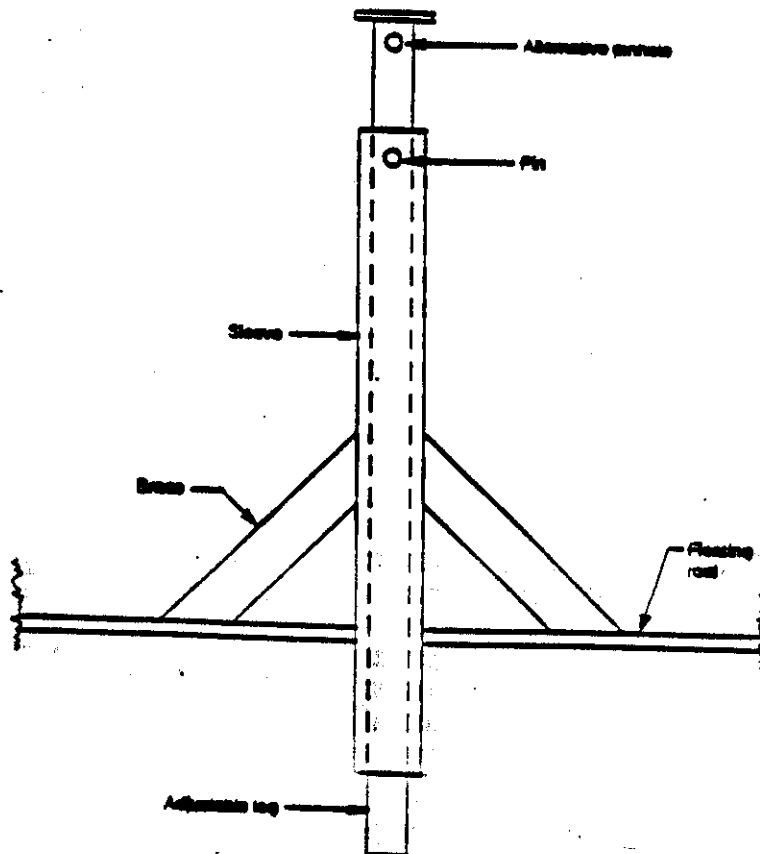
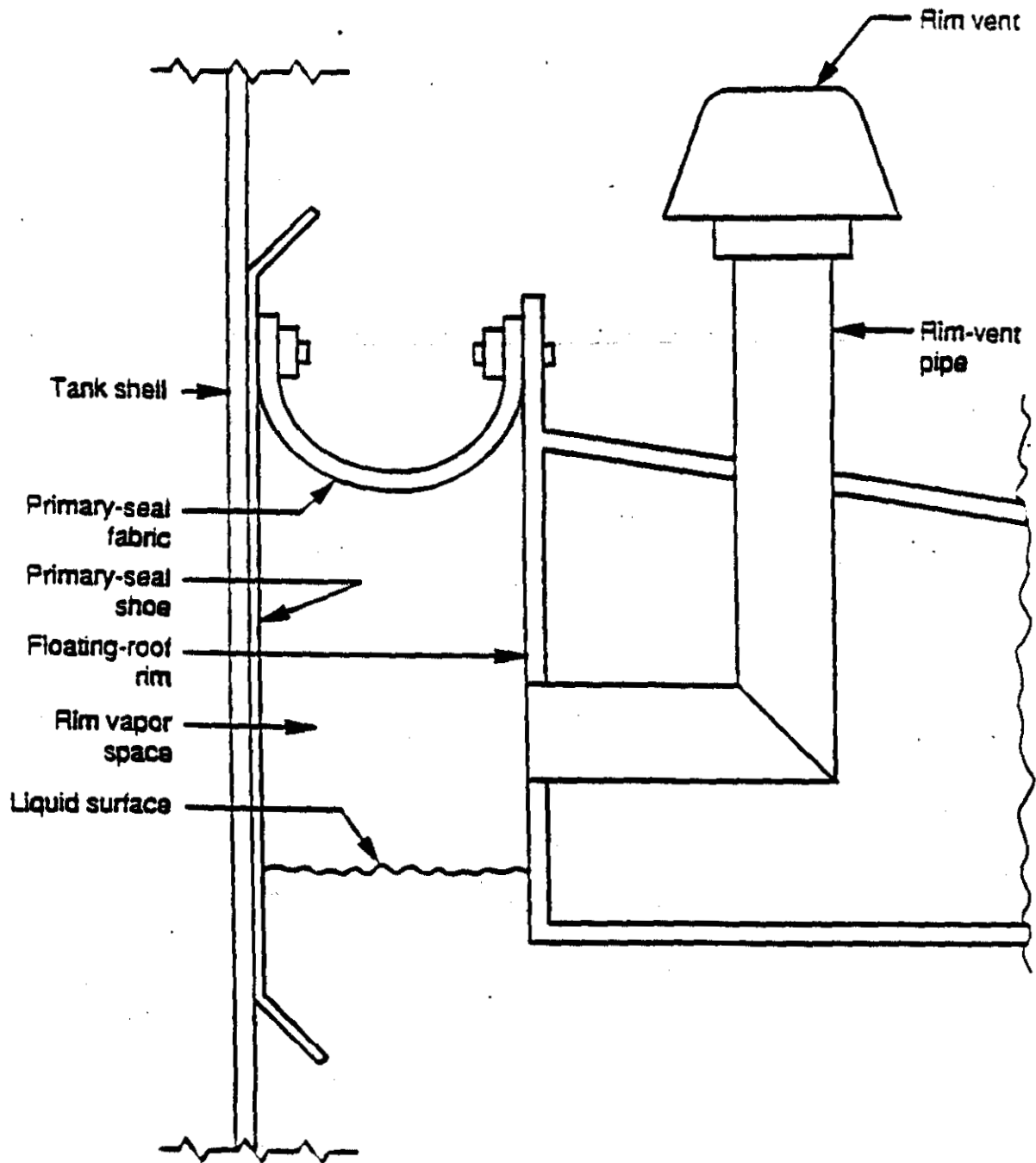

Figure 2-16b. Roof leg.²



Note: Rim vents are normally supplied only on tanks equipped with a mechanical-shoe primary seal.

Figure 2-17. Rim vent.²



2.5 REFERENCES

1. The American Petroleum Institute. Evaporative Loss from Fixed-Roof Tanks, API Draft Publication 2518, Second Edition, Washington, D.C. October 1991.
2. The American Petroleum Institute. Evaporative Loss From External Floating Roof Tanks, API Publication 2517, Third Edition. Washington, DC. February 1989.
3. Recommended Practices for Underground Storage of Petroleum. New York State Department of Environmental Conservation. Albany, NY. May 1984. p. 5.
4. Toxic Substance Storage Tank Containment. Ecology and Environment, Inc. Whitman, Requardt and Associates, Park Ridge, NJ. 1985. p. 121.
5. The American Petroleum Institute. Evaporation Loss From Internal Floating Roof Tanks, API Publication 2519, Third Edition. Washington, DC. June 1983.



3.0 EMISSION ESTIMATION PROCEDURES AND REGULATORY BASELINE

3.1 INTRODUCTION

This chapter outlines the procedures used to estimate emissions from fixed-roof tanks, horizontal tanks, and external floating roof and internal floating roof tanks. In addition, this chapter presents the regulatory baseline and analytical framework (i.e., model tanks and model liquids) used to estimate emissions for each control option presented in Chapter 4.

3.2 STORAGE TANK EMISSIONS AND EMISSION EQUATIONS

3.2.1 Fixed-Roof Tank Emissions

The major types of emissions from fixed-roof tanks are breathing and working losses. Breathing loss is the expulsion of vapor from a tank vapor space that has expanded or contracted because of daily changes in temperature and barometric pressure. The emissions occur in the absence of any liquid level change in the tank.

Filling losses are associated with an increase of the liquid level in the tank. The vapors are expelled from the tank when the pressure inside the tank exceeds the relief pressure as a result of filling. Emptying losses occur when the air that is drawn into the tank during liquid removal saturates with hydrocarbon vapor and expands, thus exceeding the fixed capacity of the vapor space and overflowing through the pressure vacuum valve. Combined filling and emptying losses are called "working losses."

Emission equations for breathing and working losses were developed for EPA Publication No. AP-42.¹ The American Petroleum Institute (API) has recently revised its recommended procedures

for estimating fixed roof tank breathing losses. The EPA has reviewed this revised procedure and incorporated it into a draft version of AP-42, which is currently undergoing external review. (Note: This ACT was prepared during the review of the revised procedure and uses the existing AP-42 to estimate emissions. Because the differences in results are small compared to overall fixed roof tank emissions, it was decided that the benefits of revising the ACT to reflect the new procedure would be small compared to the resources required to revise the calculations.) The EPA is considering incorporating this revised procedure for AP-42, and may adopt this procedure at the next revision of AP-42. For the purposes of estimating emission rates, the equations used for fixed-roof tanks storing volatile organic liquids (VOL) are:

$$L_T = L_B + L_W, \quad (3-1)$$

$$L_B = 1.02 \times 10^{-3} M_V (P/(14.7-P))^{0.68} D^{1.73} H^{0.51} T^{0.5} F_P C K_C, \quad (3-2)$$

$$L_W = 1.09 \times 10^{-4} M_V F_V N K_N K_C, \quad (3-3)$$

where:

L_T = total loss (megagrams per year [Mg/yr]);

L_B = breathing loss (Mg/yr);

L_W = working loss (Mg/yr);

M_V = molecular weight of product vapor
(pounds per pound-mole [lb/lb mole]);

P = true vapor pressure of product
(pounds per square inch absolute [psia]);

D = tank diameter (feet [ft]);

H = average vapor space height (ft); use tank-specific values or an assumed value of one-half the tank height;

T = average diurnal temperature change (°F); assume 20°F as a typical value;

F_P = paint factor (dimensionless); see Table 3-1;

C = tank diameter factor (dimensionless)
for diameter, $D \geq 30$ ft, $C = 1$,
for diameter, $6 \text{ ft} \leq D < 30 \text{ ft}$,
 $C = 0.0771 D - 0.0013 (D^2) - 0.1334$;

TABLE 3-1. PAINT FACTORS FOR FIXED-ROOF TANKS

Tank color		Paint factors (F _p)	
		Paint condition	
Roof	Shell	Good	Poor
White	White	1.00	1.15
Aluminum (specular)	White	1.04	1.18
White	Aluminum (specular)	1.16	1.24
Aluminum (specular)	Aluminum (specular)	1.20	1.29
White	Aluminum (diffuse)	1.30	1.38
Aluminum (diffuse)	Aluminum (diffuse)	1.39	1.46
White	Gray	1.30	1.38
Light gray	Light gray	1.33	1.44 ^a
Medium gray	Medium gray	1.46	1.58 ^a

^aEstimated from the ratios of the first seven paint factors.

- K_C = product factor (dimensionless) = 1.0 for VOL,
 0.65 for crude oil breathing losses, and
 0.84 for crude oil working losses;
 V = tank capacity (gallons [gal]);
 N = number of turnovers per year (dimensionless); and
 K_N = turnover factor (dimensionless)

$$\text{for turnovers } >36, K_N = \frac{180 + N}{6N} \text{ and}$$

$$\text{for turnovers } \leq 36, K_N = 1.$$

3.2.2 Horizontal Tank Emissions

The fixed-roof tank emission equations presented above in Section 3.2.1 were modified to estimate emissions from horizontal tanks. The procedure presented below is to be used only as a screening to estimate emissions from horizontal tanks, and will most likely result in an over-estimation of emissions. The modifications to the breathing loss emission estimation equation and the methodology used to calculate emissions from horizontal above-ground tanks are presented below:

1. Calculate the liquid surface area and then calculate the diameter of a circle with this same surface area. Substitute the calculated diameter of the circle for the effective tank diameter in the breathing loss equation. The liquid surface area is equal to the length of the tank multiplied by the tank diameter. Therefore, the effective diameter can be calculated using the following equation:

$$D_e = \sqrt{\frac{L D}{0.785}} \quad (3-4)$$

where:

- D_e = effective tank diameter (ft);
- L = length of tank (ft); and
- D = actual diameter of tank (ft).

2. Use half the diameter of the tank as the average vapor space height ($H = 0.5D$).

For underground tanks, assume that no breathing losses occur because the insulating nature of the earth limits the diurnal temperature change. No modifications to the working loss equation are necessary for either above-ground or underground horizontal tanks.

3.2.3 External Floating Roof Tank Emissions

Standing storage losses, which result from causes other than a change in the liquid level, constitute the major source of emissions from external floating roof tanks. The largest potential source of these losses is an improper fit between the seal and the tank shell (seal losses), resulting in portions of the liquid surface being exposed to the atmosphere. Air flowing over the tank creates pressure differentials around the floating roof. Air flows into the annular vapor space on the leeward side, and an air-vapor mixture flows out on the windward side.

Standing storage losses of VOC vapors from under the floating roof also occur through openings in the deck required for various types of fittings (fitting losses).

Withdrawal loss is another source of emissions from floating roof tanks. When liquid is withdrawn from a tank, the floating roof is lowered, and a wet portion of the tank wall is exposed. Withdrawal loss is the vaporization of liquid from the wet tank wall.

From the equations presented below, it is possible to estimate the total evaporation loss for external floating roof tanks, L_T , which is the sum of the standing storage loss, L_S , and the withdrawal loss, L_W . The equations presented in the following sections in large part are extracted from AP-42 and API Publication No. 2517.^{1,2}

3.2.3.1 Standing Storage Loss. The standing storage loss, L_S , includes losses from the rim seal and the roof fittings. The following equations can be used to estimate the independent contributions of rim seal and roof fitting losses to the overall standing storage loss:

$$L_R = F_R D P^* M_V K_C / 2,205; \text{ and} \quad (3-5)$$

$$L_F = F_F P^* M_V K_C / 2,205, \quad (3-6)$$

where:

- L_R = rim seal loss (Mg/yr);
- F_R = rim seal loss factor (pound-moles per foot-year [lb-mole/ft-yr]);
- D = tank diameter (ft);
- F_F = total roof-fitting loss factor (lb-mole/yr);
- P^* = vapor pressure function (dimensionless);
- M_V = average molecular weight of stock vapor (lb/lb-mole);
- K_C = product factor (dimensionless); and
- L_F = total roof fitting loss (Mg/yr).

Therefore, the overall standing storage loss can be estimated as follows:

$$L_S = L_R + L_F = (F_R D + F_F) P^* M_V K_C / 2,205 \quad (3-7)$$

3.2.3.1.1 Rim seal loss factor. The rim seal loss factor, F_R , can be estimated as follows:

$$F_R = K_R V^N, \quad (3-8)$$

where:

- F_R = rim seal loss factor (lb-mole/ft-yr);
- K_R = rim seal loss factor (pound-moles per [miles per hour]^N foot-year [lb-mole/(mi/hr)^N ft-yr]); see Table 3-2;
- V = average wind speed (mi/hr); and
- N = rim seal-related wind speed exponent (dimensionless); see Table 3-2.

The rim seal loss factors apply only for wind speeds from 2 to 15 miles per hour.

3.2.3.1.2 Roof fitting loss factor. The total roof fitting loss factor, F_F , can be estimated as follows:

where:

$$F_F = [(N_{F1} K_{F1} + N_{F2} K_{F2}) + \dots + (N_{FK} K_{FK})], \quad (3-9)$$

- F_F = total roof fitting loss factor (lb-mole/yr);
- N_{Fi} = number of roof fittings of a particular type (dimensionless);

TABLE 3-2. RIM-SEAL LOSS FACTORS, K_R , AND N

Tank construction and rim-seal system	Average-fitting seals	
	K_R (lb-mol/[mi/hr] ^N -ft-yr)	N (dimensionless)
WELDED TANKS		
Mechanical shoe seal		
Primary only	1.2 ^a	1.5 ^a
Shoe-mounted secondary	0.8	1.2
Rim-mounted secondary	0.2	1.0
Liquid-mounted resilient-filled seal		
Primary only	1.1	1.0
Weather shield	0.8	0.9
Rim-mounted secondary	0.7	0.4
Vapor-mounted resilient-filled seal		
Primary only	1.2	2.3
Weather shield	0.9	2.2
Rim-mounted secondary	0.2	2.6
RIVETED TANKS		
Mechanical shoe seal		
Primary only	1.3	1.5
Shoe-mounted secondary	1.4	1.2
Rim-mounted secondary	0.2	1.6

Note: The rim-seal loss factors K_R and N may only be used for wind speeds from 2 to 15 miles per hour.

^aIf no specific information is available, a welded tank with an average-fitting mechanical-shoe primary seal only can be assumed to represent the most common or typical construction and rim-seal system in use.

K_{Fi} = loss factor for a particular type of roof fitting
(lb-mole/yr);

$i = 1, 2, \dots, k$ (dimensionless); and

k = total number of different types of roof fittings
(dimensionless).

The loss factor for a particular type of roof fitting, K_{Fi} , can be estimated as follows:

$$K_{Fi} = K_{Fai} + K_{Fbi} V^{m_i}, \quad (3-10)$$

where:

K_{Fi} = loss factor for a particular type of roof fitting
(lb-mole/yr);

K_{Fai} = loss factor for a particular type of roof fitting
(lb-mole/yr);

K_{Fbi} = loss factor for a particular type of roof fitting
(lb-mole/[mi/hr]^{m_i}-yr);

m_i = loss factor for a particular type of roof fitting
(dimensionless);

$i = 1, 2, \dots, k$ (dimensionless); and

V = average wind speed, (mi/hr).

The most common roof fittings are listed in Table 3-3 along with the associated roof fitting-related loss factors, K_{Fa} , K_{Fb} , and m , for various types of construction details. These factors apply to typical roof fitting conditions. The roof fitting loss factors may only be used for wind speeds from 2 to 15 mi/hr. Since the number of each type of roof fitting can vary significantly from tank to tank, N_F values for each type of roof fitting should be determined for the tank under consideration. If this information is not available, typical N_F values are given in Tables 3-3, 3-4, and 3-5. If no information is available about the specific type and number of roof fittings, a typical total roof fitting loss factor, F_F , can be read from either Figure 3-1 or 3-2 for the type of external floating roof deck. These figures show the total roof fitting loss factor, F_F , as a function of tank diameter, D , for pontoon and double-deck floating roofs, respectively.

TABLE 3-3. ROOF FITTING LOSS FACTORS, K_{Fa} , K_{Fb} , AND m , AND TYPICAL NUMBER OF ROOF FITTINGS, N_T

Fitting type and construction details	Loss factors			Typical number of fittings, N_T
	K_{Fa} (lb-mole/yr)	K_{Fb} (lb-mole/[mi/hr] ^m -yr)	m (dimensionless)	
Access hatch (24-inch-diameter well)				1
Bolted cover, gasketed	0	0	0 ^a	
Unbolted cover, ungasketed	2.7	7.1	1.0	
Unbolted cover, gasketed	2.9	0.41	1.0	
Unslotted guide-pole well (8-inch-diameter unslotted pole, 21-inch-diameter well)				1
Ungasketed sliding cover	0	67	0.98 ^a	
Gasketed sliding cover	0	3.0	1.4	
Slotted guide-pole/sample well (8-inch-diameter unslotted pole, 21-inch-diameter well)				b
Ungasketed sliding cover, without float	0	310	1.2	
Ungasketed sliding cover, with float	0	29	2.0	
Gasketed sliding cover, without float	0	260	1.2	
Gasketed sliding cover, with float	0	8.5	2.4	
Gauge-float well (20-inch diameter)				1
Unbolted cover, ungasketed	2.3	5.9	1.0 ^a	
Unbolted cover, gasketed	2.4	0.34	1.0	
Bolted cover, gasketed	0	0	0	
Gauge-hatch/sample well (8-inch diameter)				1
Weighted mechanical actuation, gasketed	0.95	0.14	1.0 ^a	
Weighted mechanical actuation, ungasketed	0.91	2.4	1.0	
Vacuum breaker (10-inch-diameter well)				N_{F6} (Table 3-4)
Weighted mechanical actuation, gasketed	1.2	0.17	1.0 ^a	
Weighted mechanical actuation, ungasketed	1.1	3.0	1.0	
Roof drain (3-inch diameter)				N_{F7} (Table 3-4)
Open	0	7.0	1.4	
90 percent closed	0.51	0.81	1.0	
Roof leg (3-inch diameter)				N_{F8} (Table 3-5) ^c
Adjustable, pontoon area	1.5	0.20	1.0 ^a	
Adjustable, center area	0.25	0.067	1.0 ^a	
Adjustable, double-deck roofs	0.25	0.067	1.0	
Fixed	0	0	0	
Roof leg (2½-inch diameter)				N_{F8} (Table 3-5) ^c
Adjustable, pontoon area	1.7	0	0	
Adjustable, center area	0.41	0	0	
Adjustable, double-deck roofs	0.41	0	0	
Fixed	0	0	0	
Rim vent (6-inch diameter)				1 ^d
Weighted mechanical actuation, gasketed	0.71	0.10	1.0 ^a	
Weighted mechanical actuation, ungasketed	0.68	1.8	1.0	

Note: The roof fitting loss factors, K_{Fa} , K_{Fb} , and m , may only be used for wind speeds from 2 to 15 miles per hour.

^aIf no specific information is available, this value can be assumed to represent the most common or typical roof fittings currently in use.

^bA slotted guide-pole/sample well is an optional fitting and is not typically used.

^cThe most common roof leg diameter is 3 inches. The loss factors for 2½-inch-diameter roof legs are provided for use if this smaller size roof leg is used on a particular floating roof.

^dRim vents are used only with mechanical-shoe primary seals.

TABLE 3-4. TYPICAL NUMBER OF VACUUM BREAKERS, N_{F6} ,
AND ROOF DRAINS, N_{F7}

Tank diameter, D (feet) ^a	No. of vacuum breakers, N_{F6}		No. of roof drains, N_{F7} (double-deck roof)
	Pontoon roof	Double-deck roof	
50	1	1	1
100	1	1	1
150	2	2	2
200	3	2	3
250	4	3	5
300	5	3	7
350	6	4	--
400	7	4	--

Note: This table was derived from a survey of users and manufacturers. The actual number of vacuum breakers may vary greatly depending on throughput and manufacturing prerogatives. The actual number of roof drains may also vary greatly depending on the design rainfall and manufacturing prerogatives. For tanks more than 300 feet in diameter, actual tank data or the manufacturer's recommendations may be needed for the number of roof drains. This table should not supersede information based on actual tank data.

^aIf the actual diameter is between the diameters listed, the closest diameter listed should be used. If the actual diameter is midway between the diameters listed, the next larger diameter should be used.

TABLE 3-5. TYPICAL NUMBER OF ROOF LEGS, N_{F8}

Tank diameter, D (feet) ^a	Pontoon roof		No. of legs on double-deck roof
	No. of pontoon legs	No. of center legs	
30	4	2	6
40	4	4	7
50	6	6	8
60	9	7	10
70	13	9	13
80	15	10	16
90	16	12	20
100	17	16	25
110	18	20	29
120	19	24	34
130	20	28	40
140	21	33	46
150	23	38	52
160	26	42	58
170	27	49	66
180	28	56	74
190	29	62	82
200	30	69	90
210	31	77	98
220	32	83	107
230	33	92	115
240	34	101	127
250	35	109	138
260	36	118	149
270	36	128	162
280	37	138	173
290	38	148	186
300	38	156	200
310	39	168	213
320	39	179	226
330	40	190	240
340	41	202	255
350	42	213	270
360	44	226	285
370	45	238	300
380	46	252	315
390	47	266	330
400	48	281	345

Note: This table was derived from a survey of users and manufacturers. The actual number of roof legs may vary greatly depending on age, style of floating roof, loading specifications, and manufacturing prerogatives. This table should not supersede information based on actual tank data.

^aIf the actual diameter is between the diameters listed, the closest diameter listed should be used. If the actual diameter is midway between the diameters listed, the next larger diameter should be used.

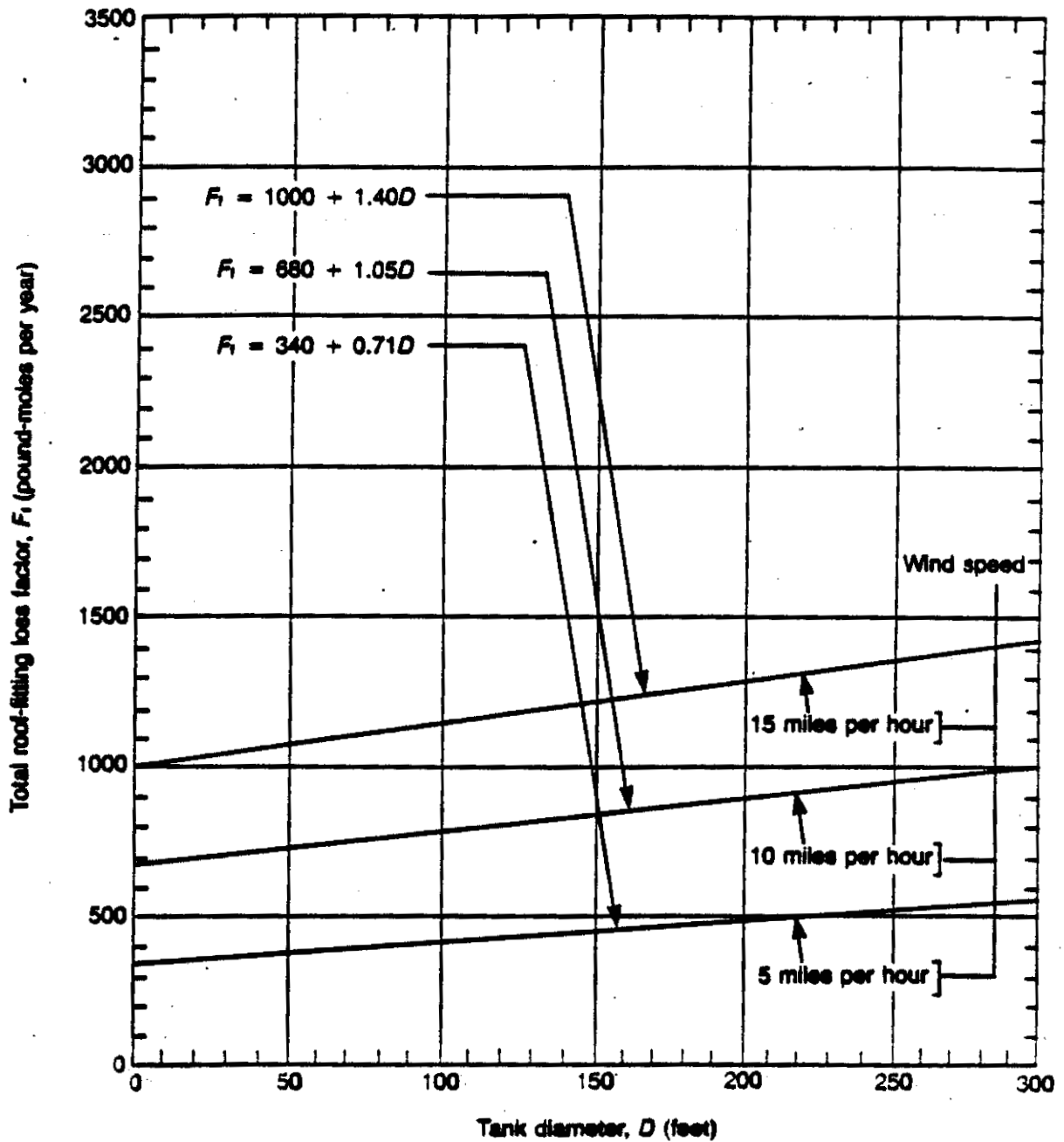

Figure 3-1. Total roof fitting loss factor for typical fittings on pontoon floating roofs.²

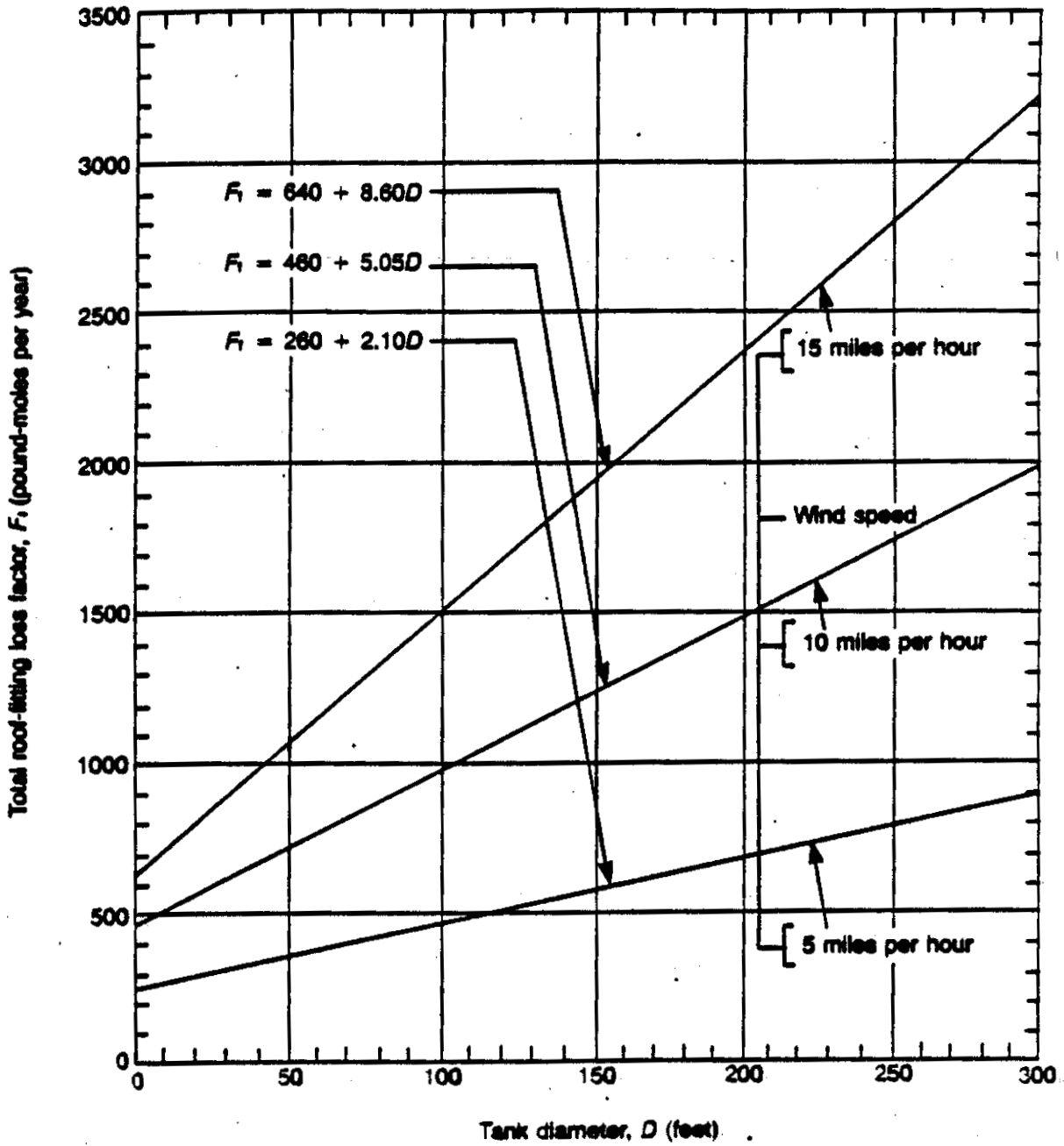

Figure 3-2. Total roof fitting loss factor for typical fittings on double-deck floating roofs.²

3.2.3.1.3 Vapor pressure function. The vapor pressure function, P^* , can be determined as follows:

$$P^* = \frac{0.068P}{[1 + (1 - 0.068P)^{0.5}]^2}, \quad (3-11)$$

where:

P^* = vapor pressure function (dimensionless); and
 P = the true vapor pressure of the materials stored (psia).

3.2.3.1.4 Product factor. The product factor, K_C , accounts for the effect of different types of product liquids on emissions. Product factors have been developed for multicomponent hydrocarbon mixtures, including refined products (such as gasolines and naphthas), crude oils, and single-component VOL's (such as petrochemicals):

K_C = 1.0 for refined products and single-component VOL's
= 0.4 for crude oils.

3.2.3.2 Withdrawal Loss. The withdrawal loss, L_W , pertains to the evaporation of liquid that clings to the tank shell while the liquid is withdrawn. The withdrawal loss can be estimated as follows:

$$L_W = \frac{0.943 Q C W_1}{2205 D}, \quad (3-12)$$

where:

L_W = withdrawal loss (Mg/yr);
 Q = annual net throughput (associated with lowering the liquid stock level in the tank) (barrels per year [bbl/yr]);
 C = clingage factor (barrels per 1,000 square feet [bbl/1,000 ft²]),
 W_1 = average liquid density at the average storage temperature (lb/gal);
 D = tank diameter (ft); and
0.943 = constant (1,000 cubic feet x gallons per barrel squared [1,000 ft³ x (gal/bbl)²]).

The annual net throughput, Q , is the total volume of stock withdrawn from the tank per year that results in a decrease in the level of the liquid in the tank. If filling and withdrawal occur equally and simultaneously so that the liquid level does not change, the net throughput is zero.

The clingage factors, C , for steel tanks with light rust, dense rust, and gunite lining in gasoline, single-component VOL, and crude oil service are presented in Table 3-6.

For refined petroleum products and crude oil, the density of the condensed vapor, W_V , is lower than the density of the stored liquid. If the density of the condensed vapor is not known, it can be approximated as follows:

where:

$$W_V = 0.08M_V, \quad (3-13)$$

W_V = density of condensed vapor (lb/gal); and

M_V = vapor molecular weight (lb/lb-mole).

For single-component VOL's, the density of the condensed vapor is equal to the density of the liquid, W_1 . The physical properties of selected petrochemicals are given in Table 3-7.

3.2.3.3 Total Loss. The total loss, L_T , in megagrams per year, can be estimated as follows:

where:

$$L_T \text{ (Mg/yr)} = L_S + L_W, \quad (3-14)$$

L_T = total loss (Mg/yr);

L_S = standing storage loss (Mg/yr); and

L_W = withdrawal loss (Mg/yr).

3.2.4 Internal Floating Roof Tank Emissions

As ambient wind flows over the exterior of an internal floating roof tank, air flows into the enclosed space between the fixed and floating roofs through some of the shell vents and out of the enclosed space through other vents. Any VOC vapors that have evaporated from the exposed liquid surface and that have not been contained by the floating deck will be swept out of the enclosed space. Vapors may also be expelled by the expansion of

TABLE 3-6. AVERAGE CLINGAGE FACTORS (C) bbl/1,000 ft²

Product	Shell condition		
	Light rust ^a	Dense rust	Gunite-lined
Gasoline	0.0015	0.0075	0.15
Single-component stocks	0.0015	0.0075	0.15
Crude oil	0.0060	0.030	0.60

^aIf no specific information is available, these values can be assumed to represent the most common/typical condition of tanks currently in use.

TABLE 3-7. PHYSICAL PROPERTIES OF SELECTED PETROCHEMICALS

Name	Formula	Molecular weight	Boiling point at 1 atmosphere (degrees Fahrenheit)	Liquid density at 60°F (pounds per gallon)	Vapor pressure (pounds per square inch absolute) at						
					40°F	50°F	60°F	70°F	80°F	90°F	100°F
Acetone	CH ₃ COCH ₃	58.08	133.0	6.828	1.682	2.185	2.862	3.713	4.699	5.817	7.251
Acetonitrile	CH ₃ CN	41.05	178.9	6.658	0.838	0.831	1.083	1.412	1.878	2.456	3.133
Acrylonitrile	CH ₂ =CHCN	63.08	173.5	6.758	0.812	0.987	1.373	1.770	2.378	3.133	4.022
Alkyl alcohol	CH ₂ nCH ₂ OH	58.08	208.8	7.125	0.135	0.193	0.261	0.387	0.522	0.718	1.008
Alkyl chloride	CH ₂ nCH ₂ Cl	78.63	113.2	7.884	2.988	3.772	4.797	6.015	7.447	9.110	11.026
Benzene	C ₆ H ₆	78.11	176.2	7.385	0.838	0.870	1.180	1.508	1.972	2.610	3.287
iso-Butyl alcohol	(CH ₃) ₂ CHCH ₂ OH	74.12	227.1	6.712	0.058	0.087	0.135	0.193	0.271	0.387	0.541
tert-Butyl alcohol	(CH ₃) ₃ COH	74.12	180.5	6.595	0.174	0.280	0.425	0.638	0.906	1.238	1.702
n-Butyl chloride	CH ₃ CH ₂ CH ₂ CH ₂ Cl	92.57	172.0	7.430	0.715	1.008	1.320	1.740	2.185	2.884	3.481
Carbon disulfide	CS ₂	76.13	115.3	10.588	3.038	3.887	4.834	6.014	7.387	9.185	11.215
Carbon tetrachloride	CCl ₄	153.84	170.2	13.388	0.793	1.084	1.412	1.788	2.301	2.997	3.771
Chloroform	CHCl ₃	119.39	142.7	12.488	1.528	1.934	2.475	3.191	4.081	5.183	6.342
Chloroprene	CH ₂ =CCl-CH=CH ₂	88.54	138.8	8.048	1.780	2.320	2.901	3.655	4.583	5.686	6.981
Cyclohexane	C ₆ H ₁₂	84.16	177.3	6.522	0.877	0.928	1.218	1.605	2.089	2.610	3.249
Cyclopentane	C ₅ H ₁₀	70.13	120.7	6.248	2.514	3.287	4.177	5.240	6.517	8.083	9.888
1,1-dichloroethane	CH ₃ CHCl ₂	98.97	135.1	8.861	1.682	2.243	2.901	3.771	4.738	5.840	7.193
1,2-dichloroethane	CH ₂ ClCH ₂ Cl	98.97	182.5	10.500	0.581	0.773	1.025	1.431	1.740	2.243	2.804
cis-1,2-dichloroethane	CHCl-CHCl	98.95	140.2	10.783	1.450	2.011	2.688	3.481	4.408	5.448	6.807
trans-1,2-dichloroethane	CHCl-CHCl	98.95	119.1	10.524	2.552	3.384	4.361	5.530	6.907	8.315	10.018
Diethylamine	(C ₂ H ₅) ₂ NH	73.14	131.9	5.908	1.644	1.892	2.682	3.867	4.882	6.130	7.541
Diethyl ether	C ₂ H ₅ OC ₂ H ₅	74.12	94.3	6.988	4.215	5.688	7.019	8.702	10.442	13.342	Boile
Di-iso-propyl ether	(CH ₃) ₂ CHOCH(CH ₃) ₂	102.17	153.5	8.075	1.189	1.588	2.127	2.748	3.481	4.254	5.288
1,4-Dioxane	O-CH ₂ CH ₂ OCH ₂ CH ₂	88.10	214.7	8.659	0.232	0.328	0.425	0.619	0.831	1.141	1.508
Dipropyl ether	CH ₃ CH ₂ CH ₂ OCH ₂ CH ₂ CH ₃	102.17	185.8	6.280	0.425	0.618	0.831	1.102	1.431	1.878	2.320
Ethyl acetate	C ₂ H ₅ COOCH ₃	88.10	170.9	7.551	0.580	0.831	1.102	1.489	1.934	2.514	3.191
Ethyl acrylate	C ₂ H ₅ COOCH=CH ₂	100.11	211.8	7.750	0.213	0.290	0.425	0.599	0.831	1.122	1.470
Ethyl alcohol	C ₂ H ₅ OH	46.07	173.1	8.810	0.193	0.408	0.618	0.870	1.218	1.682	2.320
Freon 11	CCl ₂ F	137.38	76.4	12.480	7.032	8.804	10.800	13.40	16.31	19.69	23.80
n-Heptane	CH ₃ (CH ₂) ₅ CH ₃	100.20	208.2	6.727	0.290	0.408	0.541	0.735	0.987	1.238	1.588
n-Hexane	CH ₃ (CH ₂) ₄ CH ₃	86.17	155.7	6.527	1.102	1.450	1.878	2.438	3.055	3.808	4.892
Hydrogen cyanide	HCN	27.03	78.3	6.772	6.284	7.831	9.514	11.953	16.392	18.583	22.237
Isocetane	(CH ₃) ₂ CHCH ₂ CH(CH ₃) ₂	114.22	210.8	5.784	0.213	0.387	0.580	0.812	1.093	1.392	1.740
Isopentane	(CH ₃) ₂ CHCH ₂ CH ₃	72.15	82.1	6.108	5.878	7.888	10.006	12.530	15.334	18.370	21.857
Isoprene	(CH ₂) ₂ C(CH ₃)CH=CH ₂	68.11	83.5	5.707	4.757	6.130	7.677	9.888	11.889	14.503	17.113
Isopropyl alcohol	(CH ₃) ₂ CHOH	80.09	180.1	6.573	0.213	0.328	0.483	0.677	0.928	1.298	1.779
Methacrylonitrile	CH ₂ =C(CH ₃)CN	87.09	184.5	6.738	0.483	0.657	0.870	1.180	1.470	1.934	2.458
Methyl acetate	CH ₃ COOCH ₃	74.08	134.8	7.831	1.489	2.011	2.748	3.693	4.699	5.782	6.961
Methyl acrylate	CH ₃ COOCH=CH ₂	88.09	178.9	7.996	0.599	0.773	1.025	1.364	1.788	2.388	3.055
Methyl alcohol	CH ₃ OH	32.04	148.4	6.830	0.735	1.008	1.412	1.953	2.610	3.461	4.625

3-17

TABLE 3-7. (continued)

Name	Formula	Molecular weight	Boiling point at 1 atmosphere (degrees Fahrenheit)	Liquid density at 60°F (pounds per gallon)	Vapor pressure (pounds per square inch absolute) at						
					40°F	60°F	70°F	80°F			
Acetone	CH ₃ COCH ₃	58.08	133.0	0.828	1.882	2.882	3.713	4.888	6.817	7.251	
Acetonitrile	CH ₃ CN	41.05	178.8	0.868	0.838	0.831	1.083	1.412	1.878	2.458	3.133
Acrylonitrile	CH ₂ =CHCN	53.06	173.6	0.758	0.812	0.867	1.373	1.778	2.378	3.133	4.022
Isobutyropanone	CH ₃ C(CH ₃) ₂ CO	84.10	181.3	0.874	0.808	1.160	1.644	2.234	2.882	3.818	4.544
Methylcyclohexane	CH ₂ (C ₆ H ₁₁)	98.18	213.7	0.841	0.808	0.842	0.841	0.736	0.888	1.315	1.721
Methylene chloride	CH ₂ Cl ₂	84.94	104.2	11.122	3.084	4.264	6.434	8.787	9.702	10.328	13.342
Methyl ethyl ketone	CH ₃ COCH ₂ CH ₃	72.10	176.3	0.747	0.718	0.828	1.188	1.488	2.088	2.888	3.346
Methyl methacrylate	CH ₂ =C(CH ₃)COOCH ₂ CH ₃	100.11	212.0	7.808	0.116	0.213	0.348	0.541	0.773	1.064	1.373
Methyl propyl ether	CH ₃ OC ₂ H ₅	74.12	102.1	6.188	3.074	4.738	6.081	7.088	8.417	11.802	13.728
Nitromethane	CH ₃ NO ₂	61.04	214.2	8.538	0.213	0.261	0.348	0.503	0.715	1.006	1.334
n-Heptane	CH ₂ (CH ₂) ₅ CH ₃	72.15	98.8	6.263	4.283	5.454	6.828	8.433	10.445	12.858	15.474
n-Propylamine	C ₂ H ₅ NH ₂	59.11	118.7	6.030	2.456	3.181	4.167	5.250	6.538	8.044	9.572
1,1,1-Trichloroethane	CH ₂ ClCCl ₂	133.42	186.2	11.218	0.808	1.218	1.588	2.030	2.610	3.307	4.188
Trichloroethylene	CHCl=CCl ₂	131.40	188.8	12.272	0.503	0.677	0.888	1.180	1.508	2.030	2.610
Toluene	CH ₂ (C ₆ H ₅)	92.13	231.1	7.281	0.174	0.213	0.309	0.426	0.580	0.773	1.008
Vinyl acetate	CH ₂ =CHOCOCH ₃	88.09	182.5	7.817	0.736	0.888	1.288	1.721	2.262	3.113	4.022
Vinylidene chloride	CH ₂ =CCl ₂	98.5	99.1	10.383	4.880	6.344	7.830	8.808	11.788	15.280	23.210

Note: Most of the values in this table were taken or calculated from data given in J. Timmermans, Physico-Chemical Constants of Pure Organic Compounds, Elsevier, New York, 1950, and in R. H. Perry, C. H. Chilton, and S. D. Kirkpatrick (eds.), Chemical Engineers Handbook (4th ed.), McGraw-Hill, New York, 1963.

air in the enclosed space due to diurnal temperature changes (breathing).

Losses of VOC vapors from under the floating roof occur in one of four ways:

1. Through the annular rim space around the perimeter of the floating roof (rim or seal losses);
2. Through the openings in the deck required for various types of fittings (fitting losses);
3. Through the nonwelded seams formed when joining sections of the deck material (deck seam losses); and
4. Through evaporation of liquid left on the tank wall and columns following withdrawal of liquid from the tank (withdrawal loss).

The withdrawal loss from an internal floating roof tank is similar to that discussed in the previous section for external floating roofs. The other losses--seal losses, fitting losses, and deck seam losses--occur not only during the working operations of the tank but also during free-standing periods. The mechanisms and loss rates of internal floating roof tanks were studied in detail by the Chicago Bridge and Iron Company for the American Petroleum Institute.³ The result of this work forms the following internal floating roof emissions discussion.

Several potential mechanisms for vapor loss from the rim seal area of an internal floating roof tank can be postulated. Among them are:

1. Circumferential vapor movement underneath vapor-mounted rim seals;
2. Vertical mixing, due to diffusion or air turbulence, of the vapor in gaps that may exist between any type of rim seal and the tank shell;
3. Expansion of vapor spaces in the rim area due to temperature or pressure changes;
4. Varying solubility of gases, such as air, in the rim space liquid due to temperature and pressure changes;
5. Wicking of the rim space liquid up the tank shell; and
6. Vapor permeation through the sealing material.

For external floating roof tanks, wind-generated air movement across the roof is the dominant factor affecting rim seal loss. In comparison, freely vented internal floating roof tanks significantly reduce air movement and have no clearly dominant loss mechanism.³

Vapor permeability is the only potential rim seal area loss mechanism that is readily amenable to independent investigation. Seal fabrics are generally reported to have very low permeability to typical hydrocarbon vapors, such that this source of loss is not considered to be significant. However, if a seal material is used that is highly permeable to the vapor from the stored stock, the rim seal loss could be significantly higher than that estimated from the rim seal loss equation presented later in this section.³ Additional loss data including permeability data for VOL/seal material combinations are not available to fully characterize the significance of permeability losses.

The extent to which any or all of these mechanisms contribute to the total fitting loss also is not known. The relative importance of the various mechanisms depends on the type of fitting and the design of the fitting seal.³

Floating decks are typically made by joining several sections of deck material together, resulting in seams in the deck. Because these seams are not completely vapor tight, they become a source of loss.

Emissions from internal floating roof tanks can be estimated from the equations in the following subsections.^{1,3} (Note that these equations apply only to freely vented internal floating roof tanks.)

$$L_T = L_W + L_R + L_F + L_D, \quad (3-15)$$

where:

- L_T = the total loss (Mg/yr);
- L_W = the withdrawal loss (Mg/yr);
- L_R = the rim seal loss (Mg/yr);
- L_F = the deck fitting loss (Mg/yr); and
- L_D = the deck seam loss (Mg/yr).

3.2.4.1 Withdrawal Loss. The withdrawal loss, L_W , is calculated from the following equation:

$$L_W = \frac{(0.943)QCW_L}{D} [1 + \frac{N_C F_C}{D}] / 2205, \quad (3-16)$$

where:

- L_W = withdrawal loss (Mg/yr);
- D = tank diameter (ft);
- N_C = number of columns; see Table 3-8;
- F_C = effective column diameter (ft); see Table 3-9;
- W_L = density of product (lb/gal);
- Q = product average throughput (bbl/yr); (bbl/turnover) x (turnovers/yr); and
- C = clingage factor (bbl/1,000 ft²); see Table 3-6.

3.2.4.2 Rim Seal Loss. The rim seal loss, L_R , is calculated from the following equation:

$$L_R = (K_R D) P^* M_V K_C / 2205, \quad (3-17)$$

where:

- L_R = rim seal loss (Mg/yr);
- K_R = the rim seal loss factor (lb-mole/ft-yr); rim seal loss factors for average fitting seals are as follows:

<u>Seal system description</u>	<u>K_R (lb-mole/ft-yr)</u>
Vapor-mounted primary seal only	6.7
Liquid-mounted primary seal only	3.0
Vapor-mounted primary seal plus secondary seal	2.5
Liquid-mounted primary seal plus secondary seal	1.6

D = tank diameter, ft;

P^* = the vapor pressure function (dimensionless)

$$P^* = 0.068 P / ([1 + (1 - 0.068 P)^{0.5}]^2) \text{ and}$$

P = the true vapor pressure of the material stored (psia);

M_V = the average molecular weight of the product vapor (lb/lb-mole); and

K_C = the product factor (dimensionless).

TABLE 3-8. TYPICAL NUMBER OF COLUMNS AS A FUNCTION OF TANK DIAMETERS¹

Tank diameter range D, ft	Typical number columns, N _c
0 < D ≤ 85	1
85 < D ≤ 100	6
100 < D ≤ 120	7
120 < D ≤ 135	8
135 < D ≤ 150	9
150 < D ≤ 170	16
170 < D ≤ 190	19
190 < D ≤ 220	22
220 < D ≤ 235	31
235 < D ≤ 270	37
270 < D ≤ 275	43
275 < D ≤ 290	49
290 < D ≤ 330	61
330 < D ≤ 360	71
360 < D ≤ 400	81

Note: This table was derived from a survey of users and manufacturers. The actual number of columns in a particular tank may vary greatly depending on age, roof style, loading specifications, and manufacturing prerogatives. This table should not supersede information based on actual tank data.

TABLE 3-9. EFFECTIVE COLUMN DIAMETER (F_c)

Type	F _c , ft
9-inch by 7-inch built-up columns	1.1
8-inch-diameter pipe columns	0.7
No construction details known	1.0

The product factor, K_C , is equal to 1.0 for VOL and refined products and 0.4 for crude oil.

3.2.4.3 Fitting Loss. The fitting loss, L_F , is calculated from the following equation:

$$L_F = (F_F) P^* M_V K_C / 2205, \quad (3-18)$$

where:

L_F = fitting loss (Mg/yr);

F_F = total deck fitting loss factor (lb-mole/yr);

P^* = the vapor pressure function; see Section 3.2.4.2 for the vapor pressure function calculation;

M_V = average molecular weight of product vapor (lb/lb-mole); and

K_C = the product factor (dimensionless).

The total deck fitting loss factor, F_F , is equal to:

$$F_F = \sum_{i=1}^n (N_{Fi} K_{Fi}) = [(N_{F1} K_{F1}) + (N_{F2} K_{F2}) + \dots + (N_{Fn} K_{Fn})], \quad (3-19)$$

where:

F_F = total deck fitting loss factor (lb-mole/yr);

N_{Fi} = number of fittings of a particular type (dimensionless). N_{Fi} is determined for the specific tank or estimated from Tables 3-8 and 3-10. In the case of an external floating roof tank that has been converted to an internal floating roof tank by retrofitting with a self-supporting fixed roof, Tables 3-3, 3-4, and 3-5 can be used to estimate the number of fittings.

K_{Fi} = deck fitting loss factor for a particular type fitting (lb-mole/yr); K_{Fi} is determined for each fitting type from Table 3-10; and

n = number of different types of fittings (dimensionless).

Alternatively, the total deck fitting loss factor can be estimated from either Figure 3-3 or 3-4, depending upon the type of deck and roof configuration.

TABLE 3-10. SUMMARY OF DECK FITTING LOSS FACTORS (K_F) AND TYPICAL NUMBER OF FITTINGS (N_F)

	Deck fitting type	Deck fitting loss factor, K_F (lb-mole/yr)	Typical number of fittings, N_F
1.	Access hatch a. Bolted cover, gasketed b. Unbolted cover, gasketed c. Unbolted cover, ungasketed	1.6 11 25	1
2.	Automatic gauge float well a. Bolted cover, gasketed b. Unbolted cover, gasketed c. Unbolted cover, ungasketed	5.1 15 28	1
3.	Column well a. Built-up column, sliding cover, gasketed b. Built-up column, sliding cover, ungasketed c. Pipe column, flexible fabric sleeve seal d. Pipe column, sliding cover, gasketed e. Pipe column, sliding cover, ungasketed	33 47 10 19 32	(see Table 3-8)
4.	Ladder well a. Sliding cover, gasketed b. Sliding cover, ungasketed	56 76	1
5.	Roof leg or hanger well a. Adjustable b. Fixed	7.9 0	$(5 + \frac{D}{10} + \frac{D}{600})^b$
6.	Sample pipe or well a. Slotted pipe, sliding cover, gasketed b. Slotted pipe, sliding cover, ungasketed c. Sample well, slit fabric seal, 10 percent open area	44 57 12	1
7.	Stub drain, 1-inch diameter ^a	1.2	$(\frac{D^2}{125})^b$
8.	Vacuum breaker a. Weighted mechanical actuation, gasketed b. Weighted mechanical actuation, ungasketed	0.7 0.9	1

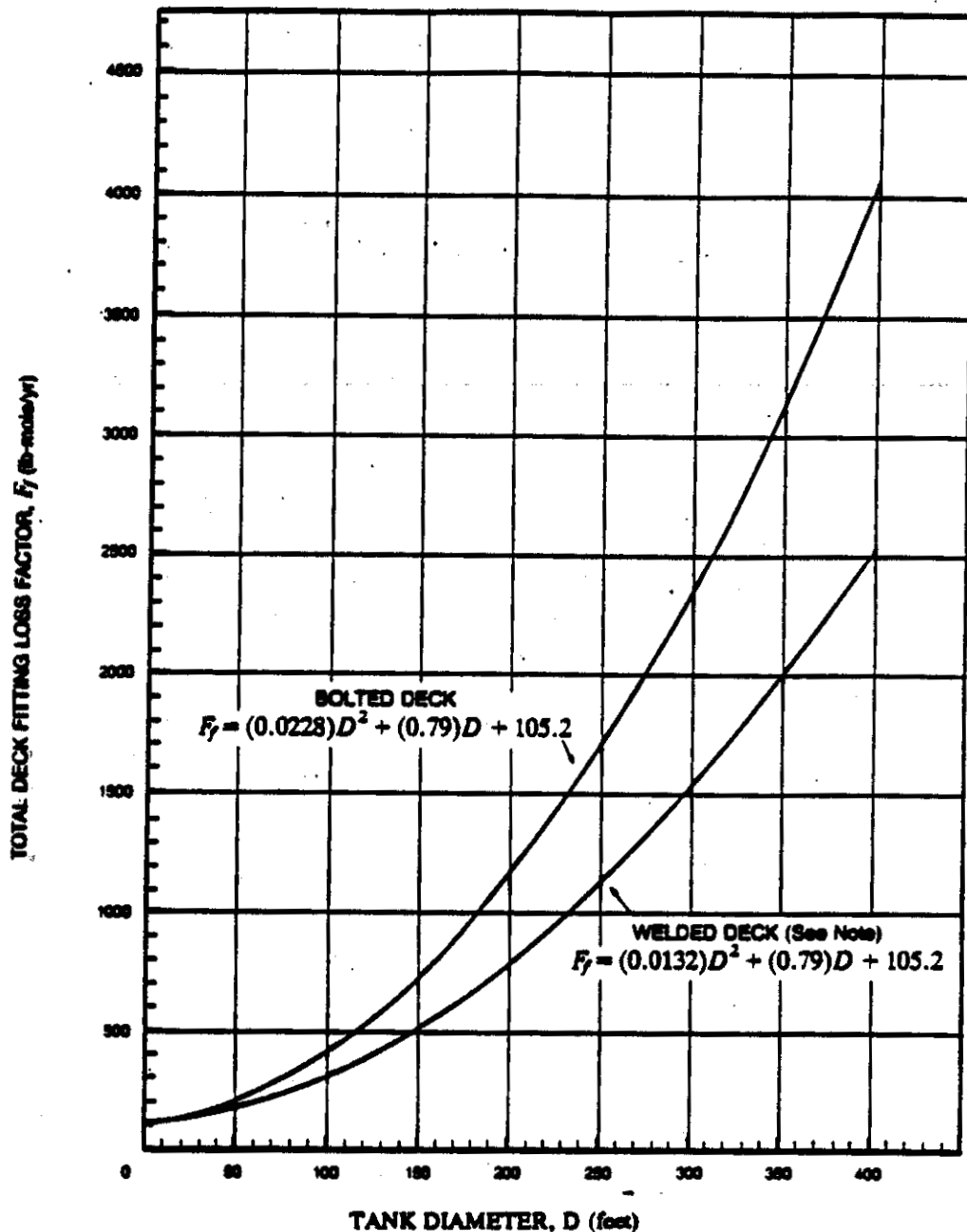

Basis: Fittings include: (1) access hatch with ungasketed, unbolted cover, (2) adjustable deck legs; (3) gauge float well with ungasketed, unbolted cover, (4) sample well with slit fabric seal (10% open area); (5) 1-inch-diameter stub drains (only on bolted deck); and (6) vacuum breaker with gasketed weighted mechanical actuation. This basis was derived from a survey of users and manufacturers. Other fittings may be typically used within particular companies or organizations to reflect standards and/or specifications of that group. This figure should not supersede information based on actual tank data.

NOTE: If no specification information is available, assume bolted decks are the most common/typical type currently in use in tanks with column-supported fixed roofs.

Figure 3-3. Total deck fitting loss factor as a function of tank diameter, for a self-supporting fixed roof.³

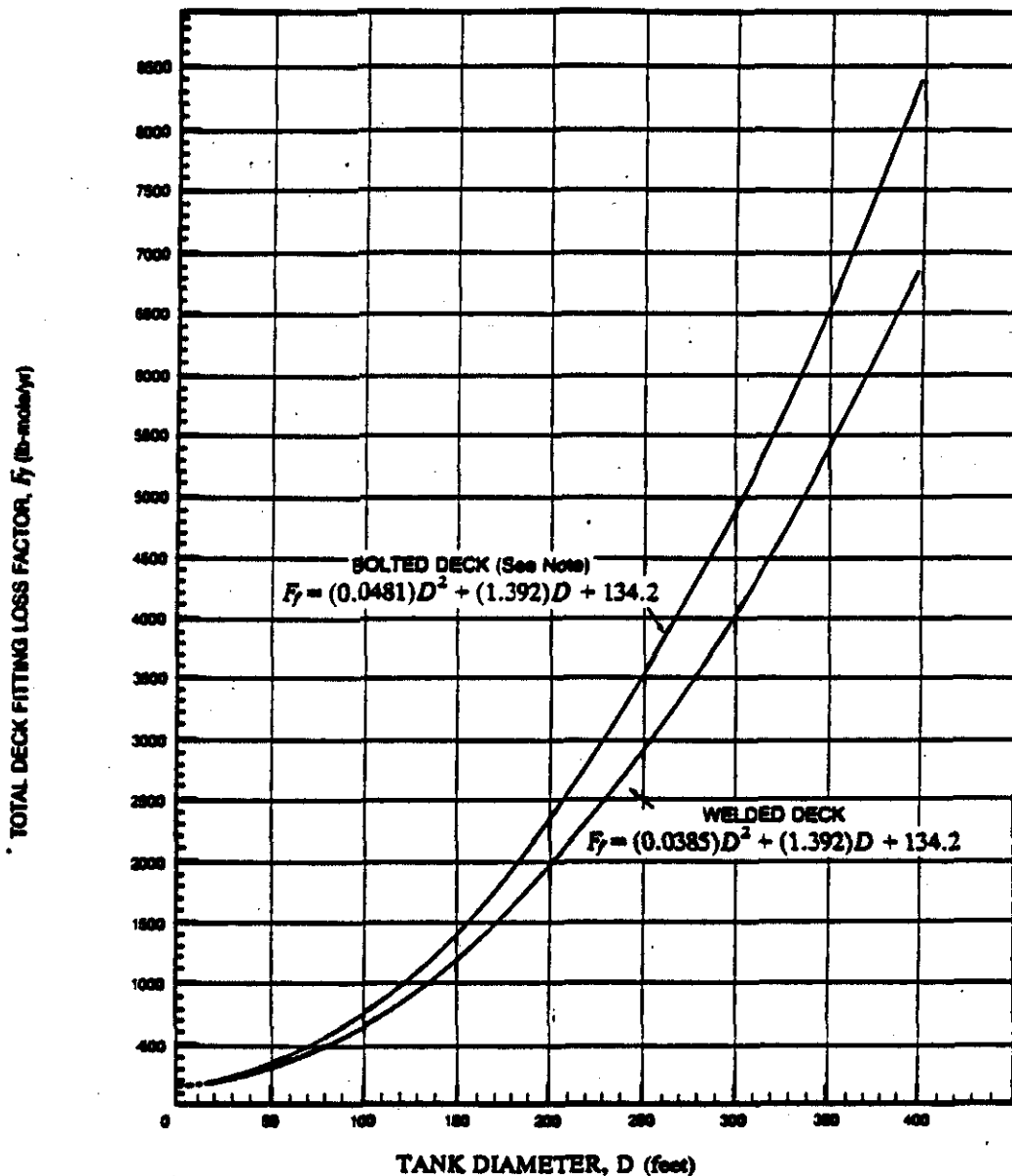

Basis: Fittings include: (1) access hatch with ungasketed, unbolting cover, (2) built-up column wells with ungasketed unbolting cover, (3) adjustable deck legs; (4) gauge float well with ungasketed, unbolting cover; (5) ladder well with ungasketed sliding cover; (6) sample well with slit fabric seal (10% open area); (7) 1-inch-diameter stub drains (only on bolted deck); and (8) vacuum breaker with gasketed weighted mechanical actuation. This basis was derived from a survey of users and manufacturers. Other fittings may be typically used within particular companies or organizations to reflect standards and/or specifications of that group. This figure should not supersede information based on actual tank data.

NOTE: If no specification information is available, assume bolted decks are the most common/typical type currently in use in tanks with column-supported fixed roofs.

Figure 3-4. Total deck fitting loss factor as a function of tank diameter, for a column-supported fixed roof.

3.2.4.4 Deck Seam Loss. The deck seam loss factor, L_D , can be calculated from the following equation:

$$L_D = (S_D K_D D^2) P^* M_V K_C / 2205, \quad (3-20)$$

where:

L_D = deck seam loss (Mg/yr);

S_D = the deck seam length factor (ft/ft²) = (L/A)

where:

L = seam length (ft) and

A = deck area (ft²);

K_D = the deck seam loss factor (lb-mole/ft-yr),

= 0.34 for nonwelded decks; and

= 0 for welded decks;

D = tank diameter, ft;

P^* = vapor pressure function (as described previously);

M_V = average molecular weight of product vapor (lb/lb-mole);
and

K_C = the product factor (dimensionless).

If total length of deck seam is unknown, use:

S_D = 0.14, for a deck constructed from continuous metal sheets with a 7-ft spacing between seams;

= 0.17, for a deck constructed from continuous metal sheets with a 6-ft spacing between seams;

= 0.33, for a deck constructed from rectangular panels 5 ft by 7.5 ft;

= 0.28, for a deck constructed from rectangular panels 5 ft by 12 ft; and

= 0.20, an approximate value for use when no construction details are known, and for a deck constructed from continuous metal sheets with a 5-ft spacing between seams.

3.3 REGULATORY BASELINE

The Environmental Protection Agency (EPA) has published two control technique guideline documents (CTG's) and promulgated three new source performance standards (NSPS) that establish the major components of the regulatory baseline. These regulatory actions are summarized in the following sections.

3.3.1 Petroleum Liquid Storage NSPS (Subpart K)⁴

The Petroleum Liquid Storage NSPS(K) (effective March 1974 for tanks between 40,000 gal and 65,000 gal; June 11, 1973 for tanks greater than 65,000 gal) marks the Agency's first regulatory action on storage tanks. Only petroleum liquids stored in tanks with volumes of 40,000 gallons and greater were affected. Petroleum liquid was defined as petroleum, condensate, and finished or intermediate refined products. The required control was the installation of a floating roof or vapor recovery system if the vapor pressure of the stored liquid was greater than 1.5 psia but less than 11.1 psia. In addition, the NSPS did not have any equipment specifications for the floating roofs. Tanks storing liquids with vapor pressures of 11.1 psia and greater were required to install vapor control devices with no specification on type or efficiency.

3.3.2 Petroleum Liquid Fixed-Roof Tank CTG⁵

This CTG was published in December 1977 and required fixed-roof tanks with volumes greater than or equal to 40,000 gal storing petroleum liquids with true vapor pressures greater than 1.5 psia to reduce emissions by equipping the tank with an internal floating roof. The CTG did not specify the type of deck, fittings, or seal system. Because the CTG applied only to petroleum liquids, the CTG did not apply to products manufactured at chemical plants (e.g., methyl ethyl ketone [MEK]) even if the tank volume and vapor pressure of the stored liquid were within the applicability range of the CTG. However, in implementing this CTG, most States expanded the applicability beyond petroleum liquids and in fact regulated all VOC-emitting tanks. Some States further strengthened their regulations beyond the CTG by requiring internal floating roof controls for smaller tanks (e.g., Texas requires internal floating roof controls on tanks with volumes of 25,000 gal and greater in nonattainment areas; New Jersey has a sliding volume-vapor pressure applicability).

3.3.3 Petroleum Liquid External Floating Roof Tank CTG⁶

This CTG was published in December 1978 and required external floating roof tanks with volumes of 40,000 gal or greater to control emissions by installing a rim-mounted secondary seal. Control of fitting emissions was not required, and applicability was limited to petroleum liquids (as defined in the fixed-roof tank CTG and the Subpart K NSPS), although "heavy, waxy, pour crudes" were specifically exempted. The vapor pressure at which controls must be installed varied as follows:

1. Tanks with vapor-mounted primary seals became affected at 1.5 psia;
2. Tanks with shoe- or liquid-mounted primary seals became affected at 4.0 psia; and
3. Riveted tanks with primary shoe seals or liquid-mounted seals became affected at 1.5 psia.

As with the fixed-roof tank CTG, the majority of States in implementing the external floating roof tank CTG broadened its applicability by controlling volatile organic compound (VOC)-emitting tanks, and they selected 40,000 gal and 1.5 psia as the cutoff point.

It is important to note that the CTG which required secondary seals for external floating roof tanks is more stringent than the Subpart K NSPS which only required the installation of a floating roof. This CTG resulted in a retrofit of tanks complying with the NSPS in nonattainment areas.

3.3.4 Subpart Ka NSPS⁷

The Subpart Ka NSPS (May 1978 for tanks constructed, reconstructed or modified) affected only petroleum liquids and contained more detailed specifications than the previous regulatory actions. The volume and vapor pressure cutoffs were 40,000 gal and 1.5 psia, respectively. The requirements for external floating roofs were very detailed and included requirements for rim-mounted secondary seals and gap specifications for both the primary and secondary seals. The Agency distinguished between vapor-mounted primary seals and other seal types by requiring a tighter fit for both the vapor-

mounted primary and the secondary seal. In addition, some requirements were included on fitting controls for external floating roof tanks. In general, all openings in the roof except for automatic bleeder vents, rim vents, and leg sleeves had to be equipped with a cover, seal, or lid, which was to be maintained in a closed position at all times except when the device was in actual use or as otherwise specified by the NSPS(Ka).

Few specifications were set for internal floating roofs. Seal and deck type were not specified, nor was any requirement included to control fitting emissions.

Vapor control devices were allowed if the control efficiency was 95 percent by weight. Vapor control was required if the vapor pressure of the stored liquid exceeded 11.1 psia.

3.3.5 Volatile Organic Liquid NSPS¹

The VOL NSPS (July 1984, 40 CFR Part 60 Subpart Kb) controlled VOC emissions from storage vessels regardless of liquid origin (i.e., both petroleum and nonpetroleum liquids were affected). The control applicability is as follows:

1. Tanks of 40,000 gal and greater storing liquids with vapor pressures of 0.75 psia and greater and
2. Tanks with volumes between 20,000 and 40,000 gal storing liquids with vapor pressures of 4 psia and greater.

The NSPS control options are:

1. An internal floating roof with controlled fittings and one of the following seal systems:
 - a. A vapor-mounted primary seal with a secondary seal or
 - b. A liquid-mounted or shoe primary seal only;
2. An external floating roof equipped with a shoe or liquid-mounted primary seal and a secondary seal; and
3. A 95 percent-by-weight vapor control system.

Vapor control was required for all affected tanks storing liquids with vapor pressures of 11.1 psia or greater.

Although the NSPS specified equipment to control internal floating roof fitting losses, no controls were required beyond those previously specified by the Subpart Ka NSPS for external

floating roof fittings. Also, the NSPS made no provisions to exempt heavy, waxy, pour crude oils.

The shoe seal was allowed for internal floating roofs, in part to allow the storage of problem liquids and to allow for the conversion from an external floating roof tank to an internal floating roof tank by retrofitting with a self-supporting fixed roof. Shoe seals are made of steel and can be used with welded steel internal floating roofs. If the liquid can be stored in a steel tank, this type of system should be appropriate. The only potential problem is ensuring the seal fabric is compatible with the product vapor.

3.3.6 Results of Regulatory Actions

The history of regulatory action makes the baseline control scenario complex. Due to the fixed-roof tank CTG, it is reasonable to assume that all fixed-roof tanks with volumes of 40,000 gal and greater storing liquids with true vapor pressures of 1.5 psia or greater were converted to internal floating roof tanks in nonattainment areas. This conversion occurred because the majority of the States did not distinguish between petroleum liquids and other VOL's in implementing the CTG. Because the control cutoffs of the petroleum NSPS are also 40,000 gal and 1.5 psia, and compliance for all three regulatory actions could be achieved with a low-cost, noncontact internal floating roof with a vapor-mounted primary seal only and uncontrolled fittings, it is reasonable to assume this type of internal floating roof tank as the baseline, as opposed to other, higher-cost control options. Below 40,000 gal or 1.5 psia, few States require controls. Therefore, it is reasonable to assume only fixed-roof tanks exist with volumes less than 40,000 gal or volumes above 40,000 gal storing liquids less than 1.5 psia.

The external floating roof baseline cases are more complex because of previous regulatory actions affecting these tanks. First, as a result of the CTG and the NSPS(Ka), it is reasonable to assume riveted external floating roof tanks in nonattainment areas are controlled with rim-mounted secondary seals at vapor

pressures of 1.5 psia and greater. For these riveted tanks, it is reasonable to assume a shoe seal as the primary seal. Second, some welded tanks are equipped with vapor-mounted primary seals. These are divided into a controlled (rim-mounted secondary seal) subgroup, which can be defined as having liquid vapor pressures of 1.5 psia and greater, and an uncontrolled subgroup, with vapor pressures less than 1.5 psia. Third, the populations of external floating roofs with liquid-mounted or shoe seals may be categorized as: (1) tanks uncontrolled by both the NSPS(Ka) and the CTG (i.e., vapor pressures less than 1.5 psia or vapor pressures less than 4.0 psia constructed prior to May 8, 1978); (2) tanks controlled by both the NSPS(Ka) and the CTG (i.e., tanks storing liquids with vapor pressures exceeding 4.0 psia); and (3) tanks controlled by the NSPS(Ka) but not controlled by the CTG (i.e., tanks storing liquids with vapor pressures between 1.5 psia and 4 psia constructed after May 8, 1978).

3.4 MODEL LIQUIDS AND MODEL TANKS

3.4.1 Model Liquids

The emissions estimation procedures distinguish between crude oils and other single-component or refined stocks. Therefore, a series of model crude oils and single-component stocks have been provided to represent the range of stored liquids. Further information on these model liquids is presented in the following sections.

3.4.1.1 Model Crude Oil. The properties of crude oils vary widely. For the purpose of this analysis, the physical properties of crude oil Reid vapor pressure (RVP) 5 were selected. Crude oil RVP 5 has a molecular weight of 50 and a density of 7.1 lb/gal. The total vapor pressure in the analysis varied from 0.10 to 5.0 psia. The product value used in analyzing crude oil was \$15.00/bbl.

3.4.1.2 Model VOL's. To represent single-component liquids and refined products, two model VOL's have also been used in the analysis. One model VOL is representative of nonhalogenated compounds, and the other is representative of halogenated

compounds. Two model VOL's were chosen because of the effect of the physical properties of the stored liquid on emissions and the compatibility of the liquid with the materials of construction. The model nonhalogenated compound has a molecular weight of 60 and a density of 6.6 lb/gal, whereas the model halogenated VOL has a molecular weight of 100 and a density of 10.5 lb/gal. The vapor pressures examined in the analysis for the model nonhalogenated VOL ranged from 0.1 to 5.0 psia. The vapor pressures examined for the model halogenated VOL were lower, ranging from 0.1 to 1.0 psia. The vapor pressure range for the model halogenated VOL is lower than that of the model nonhalogenated VOL because halogenated compounds typically have much lower vapor pressures than nonhalogenated compounds. The product value selected for both the halogenated and nonhalogenated VOL's was \$0.71/lb. This value is representative of the most common VOL compounds used in industry.

3.4.2 Model Tanks

Table 3-11 presents the analytical framework for fixed-roof tanks. Eleven model tanks were selected to represent typical storage tank sizes. The model tanks range in size from approximately 10,000 gal up to 2 million gal. Model annual turnover rates were also developed for fixed-roof tanks. Annual turnover rates of 10, 25, 30, 50, and 100 were selected for tanks less than 40,000 gal. Annual turnover rates of 5, 10, 20, and 30 were selected for tanks greater than 40,000 gal. These values are believed to be representative of the tanks that are discussed in this ACT. The turnover rate values may not be representative of large chemical production facilities that conceivably could have annual turnover rates as high as 400. However, the turnover rates selected for analyses would be more representative of chemical users than producers. The model liquids and vapor pressure ranges examined in the analysis for each model tank are also shown in Table 3-11. The model liquid and vapor pressure ranges were selected considering the current regulatory baseline. For instance, the fixed-roof tank CTG requires all fixed-roof tanks above 40,000 gal that store liquids

TABLE 3-11. FIXED-ROOF MODEL TANKS^a

Capacity		Diameter		Height		Vapor pressure		Liquid type
m ³	gallons	meters	feet	meters	feet	kPa	psia	
37.9	10,000 (horizontal)	3.0	10.0	5.5	18	27.6	4	VOL
						13.8	2	VOL
						6.9	1	VOL
						3.4	0.5	VOL
75.9	20,000 (horizontal)	3.7	12	7.3	24	27.6	4	VOL
						13.8	2	VOL
						6.9	1	VOL
						3.4	0.5	VOL
75.7	20,000	4.6	15.0	4.6	15	27.6	4	VOL
						13.8	2	VOL
						6.9	1	VOL
						3.4	0.5	VOL
151	40,000	5.5	18	6.4	21	10.3	1.5	VOL
						6.9	1.0	VOL
						3.4	0.5	VOL/crude oil
						1.7	0.25	VOL/crude oil
307	81,180	7.3	24	7.3	24	10.3	1.5	VOL
						6.9	1.0	VOL
						3.4	0.5	VOL/crude oil
						1.7	0.25	VOL/crude oil
307	81,180	7.3	24	7.3	24	0.69	0.10	VOL/crude oil
						6.9	1.0	VOL
						3.4	0.5	VOL/crude oil
						1.7	0.25	VOL/crude oil

TABLE 3-11. (continued)

Capacity		Diameter		Height		Vapor pressure		Liquid type
m ³	gallons	meters	feet	meters	feet	kPa	psia	
37.9	10,000 (horizontal)	3.0	10.0	5.5	18	27.6	4	VOL
481	127,000	9.1	30	7.3	24	10.3	1.5	VOL
						6.9	1.0	VOL
						3.4	0.5	VOL/crude oil
						1.7	0.25	VOL/crude oil
						0.69	0.10	VOL/crude oil
758	200,200	9.1	30	11.6	38	10.3	1.5	VOL
						6.9	1.0	VOL
						3.4	0.5	VOL/crude oil
						1.7	0.25	VOL/crude oil
						0.69	0.10	VOL/crude oil
1,278	337,700	12.2	40	11	36	10.3	1.5	VOL
						6.9	1.0	VOL
						3.4	0.5	VOL/crude oil
						1.7	0.25	VOL/crude oil
						0.69	0.10	VOL/crude oil
1,916	506,000	14.9	49	11	36	10.3	1.5	VOL
						6.9	1.0	VOL
						3.4	0.5	VOL/crude oil
						1.7	0.25	VOL/crude oil
						0.69	0.10	VOL/crude oil

3-35

TABLE 3-11. (continued)

Capacity		Diameter		Height		Vapor pressure		Liquid type
m ³	gallons	meters	feet	meters	feet	kPa	psia	
37.9	10,000 (horizontal)	3.0	10.0	5.5	18	27.6	4	VOL
3,832	1,012,200	18.3	60	12.2	48	10.3	1.5	VOL
						6.9	1.0	VOL
						3.4	0.5	VOL/crude oil
						1.7	0.25	VOL/crude oil
						0.69	0.10	VOL/crude oil
7,552	1,995,060	25.9	85	14.3	47	10.3	1.5	VOL
						6.9	1.0	VOL
						3.4	0.5	VOL/crude oil
						1.7	0.25	VOL/crude oil
						0.69	0.10	VOL/crude oil

^aAnnual turnovers are 5, 10, 20, and 30 for tanks 40,000 gallons and greater and 10, 25, 50, and 100 for tanks less than 40,000 gallons.

with true vapor pressures above 1.5 psia to install either an internal floating roof or a vapor recovery system. Therefore, the vapor pressure range examined for tanks greater than 40,000 gal was limited to tanks storing liquids below 1.5 psia.

Table 3-12 presents the analytical framework for internal and external floating roof tanks. Eight model tanks were developed to represent typical tank sizes. The vapor pressure range and model liquids examined for each model tank were selected considering the existing regulatory baseline as with fixed-roof tanks.

TABLE 3-12. ANALYTICAL FRAMEWORK FOR INTERNAL FLOATING ROOF AND EXTERNAL FLOATING ROOF MODEL TANKS

Capacity		Diameter		Height		Vapor pressure		Liquid type
m ³	gallons	meters	feet	meters	feet	kPa	psia	
151	40,000	5.5	18	6.4	21	34.5	5.0	VOL
						13.8	2.0	VOL
						6.9	1.0	VOL/crude oil
						3.5	0.5	VOL/crude oil
						1.7	0.25	VOL/crude oil
						0.69	0.10	VOL/crude oil
307	81,180	7.3	24	7.3	24	34.5	5.0	VOL
						13.8	2.0	VOL
						6.9	1.0	VOL/crude oil
						3.5	0.5	VOL/crude oil
						1.7	0.25	VOL/crude oil
						0.69	0.10	VOL/crude oil
481	127,000	9.1	30	7.3	24	34.5	5.0	VOL
						13.8	2.0	VOL
						6.9	1.0	VOL/crude oil
						3.5	0.5	VOL/crude oil
						1.7	0.25	VOL/crude oil
						0.69	0.10	VOL/crude oil
758	200,200	9.1	30	11.6	38	34.5	5.0	VOL
						13.8	2.0	VOL
						6.9	1.0	VOL/crude oil
						3.5	0.5	VOL/crude oil
						1.7	0.25	VOL/crude oil
						0.69	0.10	VOL/crude oil

TABLE 3-12. (continued)

Capacity		Diameter		Height		Vapor pressure		Liquid type
m ³	gallons	meters	feet	meters	feet	kPa	psia	
151	40,000	5.5	18	6.4	21	34.5	5.0	VOL
1,278	337,700	12.2	40	11	36	34.5	5.0	VOL
						13.8	2.0	VOL
						6.9	1.0	VOL/crude oil
						3.5	0.5	VOL/crude oil
						1.7	0.25	VOL/crude oil
						0.69	0.10	VOL/crude oil
1,916	506,000	14.9	49	11	36	34.5	5.0	VOL
						13.8	2.0	VOL
						6.9	1.0	VOL/crude oil
						3.5	0.5	VOL/crude oil
						1.7	0.25	VOL/crude oil
						0.69	0.10	VOL/crude oil
3,832	1,012,200	18.3	60	12.2	48	34.5	5.0	VOL
						13.8	2.0	VOL
						6.9	1.0	VOL/crude oil
						3.5	0.5	VOL/crude oil
						1.7	0.25	VOL/crude oil
						0.69	0.10	VOL/crude oil
7,552	1,995,060	25.9	85	14.3	47	34.5	5.0	VOL
						13.8	2.0	VOL
						6.9	1.0	VOL/crude oil
						3.5	0.5	VOL/crude oil
						1.7	0.25	VOL/crude oil
						0.69	0.10	VOL/crude oil



3.5 REFERENCES

1. U. S. Environmental Protection Agency. Compilation of Air Pollution Emission Factors, Report No. AP-42, Supplement 12. Research Triangle Park, NC. April 1981.
2. The American Petroleum Institute. Evaporative Loss From External Floating Roof Tanks, API Publication 2517, Third Edition. Washington, DC. February 1989.
3. The American Petroleum Institute. Evaporation Loss From Internal Floating Roof Tanks, API Publication 2519, Third Edition. Washington, DC. June 1983.
4. 40 CFR Part 60 Subpart K; promulgated March 8, 1974.
5. The Control of Volatile Organic Emissions From Storage of Petroleum Liquids in Fixed Roof Tanks. EPA-450/2-77-036. Research Triangle Park, NC. December 1977.
6. Control of Volatile Organic Emissions From Petroleum Liquid Storage in External Floating Roof Tanks. EPA-450/2-78-047. Research Triangle Park, NC. December 1978.
7. 40 CFR Part 60 Subpart Ka; promulgated April 4, 1980.
8. 40 CFR Part 60 Subpart Kb; promulgated April 8, 1987.



4.0 CONTROL TECHNIQUES

4.1 OVERVIEW

This section describes the control techniques that apply to volatile organic compound (VOC) emissions from storing volatile organic liquids (VOL's).

As discussed in Chapter 2, three major types of vessels are used to store VOL's: fixed roof tanks, internal floating roof tanks, and external floating roof tanks. In addition, optional equipment designs exist within each major tank type (e.g., seal design, roof fabrication, and fittings closure). Each tank type and equipment option has its own associated emission rate. In effect, there is a spectrum of equipment options, with a corresponding spectrum of emission rates.

Considering the optional types of equipment that can be used to store VOL's, a general hierarchy, or ranking, of equipment alternatives can be developed for fixed roof tanks, internal floating roof tanks, and external floating roof tanks based on emission rates. These hierarchies, in order of decreasing emission rates, are listed in Tables 4-1 and 4-2. There are other ranking scenarios that could be developed depending on the specific types of fittings used, however, the hierarchy of options presented in this document are meant to represent general groups of equipment alternatives. Comparison of actual control performance should use actual tank data. Chapter 3 outlines equations for estimating the emission rate for each of the major tank types and the equipment options that are available. These equations and the test data used to develop the equations form the basis for evaluating the effectiveness of the control techniques discussed in this chapter.

TABLE 4-1. FIXED ROOF AND INTERNAL FLOATING ROOF TANKS--
HIERARCHY OF EQUIPMENT TYPES BASED ON EMISSIONS RATE^{a,b}

Control option	Equipment description	Abbreviated notation
1	Fixed roof tank (baseline)	Fixed roof tank
2	Internal floating roof tank, bolted construction (contact or noncontact), vapor-mounted primary seal with uncontrolled deck fittings ^c	$bIFR_{vm,uf}$
3	Internal floating roof tank, bolted construction (contact or noncontact), vapor-mounted primary and <u>secondary seals</u> with controlled deck fittings	$bIFR_{vm,ss,cf}$
4	Internal floating roof tank, bolted construction (contact or noncontact), <u>liquid-mounted or shoe primary and secondary seals</u> , with controlled deck fittings	$bIFR_{lm,ss,cf}$
5	Internal floating roof tank, <u>welded construction (steel pan or FRP deck)</u> , liquid-mounted or shoe primary and secondary seals, with controlled deck fittings	$wIFR_{lm,ss,cf}$

^aListed in order of decreasing emission rates with Control Option 1 having the largest emission rate and Control Option 6 having the smallest emission rate.

^bSelf-supporting fixed roofs would result in lower emission rates for each control option.

^cFor new installations, some vendors of internal floating roofs supply the roofs with both vapor-mounted primary and secondary seals at no additional cost beyond the basic roof cost.

TABLE 4-2. EXTERNAL FLOATING ROOF TANKS--
HIERARCHY OF EQUIPMENT TYPES BASED ON EMISSIONS RATE^{a,b}

Control option	Equipment description	Abbreviation notation
1	Baseline: External floating roof tank, riveted construction with mechanical shoe primary seal	EFR _{ms}
2	External floating roof tank, riveted construction with mechanical shoe primary seal and <u>secondary seal with controlled fittings</u>	EFR _{ms,cf,ss}
3	Baseline: External floating roof tank, welded construction with vapor-mounted primary seal.	EFR _{vm}
4	External floating roof tank with vapor-mounted primary and <u>secondary seals with controlled fittings</u>	EFR _{vm,cf,ss}
5	External floating roof tank with <u>liquid-mounted primary and secondary seals with controlled fittings</u>	EFR _{lm,cf,ss}

^aListed in order of decreasing emission rates with Control Option 1 having the largest emission and Control Option 5 having the smallest emission rate.

^bConversion to an internal floating roof tank by retrofitting with a self-supporting fixed roof would result in lower emission rates for each control option.

Decreasing the annual turnover rate decreases the emission rate for fixed roof tanks. Conversely, the turnover rate has little effect on internal and external floating roof tank emission rates. Therefore, the higher the turnover rate, the larger the difference between fixed roof and floating roof tank emission rates.

The vapor pressure of the stored VOL has an effect on the relative emission rates of the equipment options. As the vapor pressure of the stored liquid increases, the emission rates from both fixed and floating roof tanks increase. However, the vapor pressure functions in the equations used to estimate losses from fixed and floating roof tanks are different and the percent increase in floating roof tank emissions is greater than the percent increase in fixed roof tank emissions for a similar increment in vapor pressure. Within the range of conditions commonly found in VOL storage vessels, however, neither the effect of the vapor pressure nor the turnover rate changes the rank of the fixed roof tank and floating roof tank equipment options.

4.2 FIXED ROOF TANKS

A fixed roof tank is the minimum acceptable equipment currently employed for storing VOL. The discussion of control techniques, therefore, relates the effectiveness of alternative storage equipment types to the effectiveness of fixed roof tanks. Working and breathing losses normally incurred from storing VOL in fixed roof tanks can be reduced in the following ways:

1. By installing an internal floating roof with appropriate fittings and one of the seal systems previously discussed in Chapter 2; or
2. By installing and using a vapor recovery system (e.g., carbon adsorption or refrigerated condensation) or a vapor control system (e.g., incineration).

This list defines only the major types of control techniques that apply to VOL storage. Optional equipment designs that influence the effectiveness of minimizing VOL emissions exist within each major type of control technique. The following

sections discuss the relative effectiveness of these equipment options.

4.3 INTERNAL FLOATING ROOF TANKS

Internal floating roof tanks with rim seal systems emit less VOC per unit of storage than fixed roof tanks. Internal floating roofs can be used directly as a control device for existing fixed roof tanks.

Depending on the type of roof and seal system selected, the number of turnovers, tank volume, and liquid type, installing an internal floating roof in a model fixed roof tank reduces the emission rate by 69 to 98 percent. An internal floating roof, regardless of design, reduces the area of exposed liquid surface in the tank. Reducing the area of exposed liquid surface, in turn, decreases the evaporative losses. The majority of the emissions reduction is achieved through the floating roof vapor barrier that precludes direct contact between a large portion of the liquid surface and the atmosphere. All floating roofs share this design benefit. The relative effectiveness of one floating roof design over another, therefore, is a function of how well the floating roof can be sealed.

From an emissions standpoint, the most basic internal floating roof design is the noncontact, bolted, aluminum internal floating roof with a single vapor-mounted wiper seal and uncontrolled fittings. Though the NSPS (40 CFR 60 Subpart Kb) requires the use of a secondary seal with vapor-mounted primary seals, there are many existing tanks not covered by NSPS that have only a single vapor-mounted primary seal. As discussed in Chapter 3, there are four types of losses from this design. These losses, with an estimate of their respective percentage contributions to the total loss from an internal floating roof tank (volume = 481 cubic meters [m^3] (16,980 cubic feet [ft^3]); vapor pressure = 6.9 kiloPascals [kPa] (1 pound per square inches [psia])), are as follows:

1. Rim or seal losses--35 percent;
2. Fitting losses--35 percent;
3. Deck seam losses--18 percent; and

4. Withdrawal losses--12 percent.

These percentages will vary as a function of tank diameter, equipment type, and throughput.

With the exception of withdrawal losses, which are inherent in all floating roof designs, the losses listed above can be reduced by using roofs with alternative design features. The following sections elaborate on the alternative equipment that can be employed on internal floating roofs. The discussion is arranged according to the major emissions categories.

4.3.1 Controls for Fitting Losses

Fitting losses occur through the penetrations in an internal floating deck. Penetrations exist to accommodate the various types of fittings that are required for proper operation of an internal floating roof. Fitting losses can be controlled with gasketing and sealing techniques or by substituting a lower-emitting fitting type that serves the same purpose. Table 4-3 lists the fitting types that are pertinent to emissions and an abbreviated description of the equipment that is considered to be representative of "uncontrolled" fittings and "controlled" fittings.¹ Certain fitting types are not amenable to control. These are not listed in Table 4-3.

4.3.2 Controls for Seal Losses

Internal floating roof seal losses can be minimized in either one of two ways or their combination:

1. By employing liquid-mounted primary seals instead of vapor-mounted seals; and/or
2. By employing secondary seals in addition to primary seals.

All seal systems should be designed, installed, and maintained to minimize the gap between the seals and the tank shell. Data from emission tests conducted on internal floating roof tanks support the general conclusion that seal losses increase rapidly when the seal gap exceeds 63.5 square centimeters per meter (cm^2/m) (3 square inches per foot [in^2/ft]) of tank diameter. Below this level, the effect of seal gap on seal loss is much less pronounced.

TABLE 4-3. "CONTROLLED" AND "UNCONTROLLED" INTERNAL FLOATING ROOF DECK FITTINGS¹

Deck fitting type	Equipment descriptions	
	Uncontrolled	Controlled
1. Access hatch	Unbolted, ungasketed cover [*] ; or unbolted, gasketed cover	Bolted, gasketed cover
2. Automatic gauge float well	Unbolted, ungasketed cover [*] ; or unbolted, gasketed cover	Bolted, gasketed cover
3. Column well	Built-up column-sliding cover, ungasketed [*] ;	Built-up column-sliding cover, gasketed; or Pipe column-flexible fabric sleeve seal for tanks with pipe columns
4. Ladder well	Ungasketed sliding cover [*]	Gasketed sliding cover
5. Sample pipe or well	Slotted pipe-sliding cover, ungasketed; or slotted pipe-sliding cover, gasketed	Sample well with slit fabric seal, 10% open area [*]
6. Vacuum breaker	Weighted mechanical actuation, ungasketed [*]	Weighted mechanical actuation, gasketed

*The fittings assumed in the uncontrolled case for estimating the effectiveness of fittings controls are marked with a single asterisk in the above table. This fittings scenario is representative of no single tank, but rather is the composite of what is estimated based on a survey of users and manufacturers to be typical of fittings on the majority of tanks currently in service. Note that the sample well with slit fabric seal was used in the "uncontrolled" case for calculating emissions because it is in common use. It was also used in the "controlled" case because it is the lowest emitting fitting type.

The effectiveness of alternate internal floating roof seal systems can be evaluated through inspection of the rim seal loss factors (K_R) that have been developed based on test data for estimating losses for various seal systems. These factors are listed in Table 4-4.

4.3.3 Deck Seam Losses

Depending on the type of floating roof employed, deck seam losses can contribute to the total loss from an internal floating roof. For the model tank used as a basis for comparison throughout this section (i.e., $bIFR_{vm,uf}$), deck seam losses are 18 percent of the total loss.

Deck seam losses are inherent in several floating roof types. Any roof constructed of sheets or panels fastened by mechanical fasteners (bolted) is expected to experience deck seam losses. Deck seam losses are considered to be a function of the length of the seams only and not the type of the seam or its position relative to the liquid surface. Selecting a welded roof rather than a bolted roof eliminates deck seam losses.

4.4 EXTERNAL FLOATING ROOF TANKS

Most external floating roof tanks are constructed of welded steel and are equipped with shoe primary seal systems. There are still a significant number of tanks storing liquids with vapor pressures less than 1.5 psia with no secondary seal. Because these tanks do not experience deck seam losses, there are only three types of losses that can result from this roof design:

1. Rim or seal losses;
2. Fitting losses; and
3. Withdrawal losses.

These losses, with an estimate of their respective contributions to the total loss from an external floating roof tank (volume = 481 m³; vapor pressure = 6.9 kPa [the same capacity and vapor pressure as the tank used to estimate internal floating roof tank emissions]) are as follows:

1. Rim or seal losses--68 percent;
2. Fitting losses--28 percent; and
3. Withdrawal losses--4 percent.

TABLE 4-4. INTERNAL FLOATING ROOF RIM SEAL SYSTEMS SEAL LOSS FACTORS AND CONTROL EFFICIENCIES

Seal system	K_R (lb-mole/ft-year)	Seal loss control efficiency related to baseline
Vapor-mounted primary seal only	6.7	IFR baseline (0%)
Liquid mounted or shoe primary seal only	3.0	55%
Vapor-mounted primary and secondary seals	2.5	63%
Liquid-mounted or shoe primary and secondary seals	1.6	76%

These percentages can vary drastically according to tank diameter, equipment type, and throughput.

With the exception of withdrawal losses, which are inherent in all floating roof designs, the losses listed above can be reduced by employing roofs with alternative design features. The following sections elaborate on the alternative equipment that can be used on external floating roofs. The discussion is arranged according to the major emissions categories.

Rim seal losses that are similar in nature to those experienced by internal floating roof tanks also occur with external floating roof tanks. The only difference in this respect between external floating roofs and internal floating roofs is that the external floating roof seal losses are believed to be dominated by wind-induced mechanisms.

4.4.1 Controls for Fitting Losses

Fitting losses from external floating roof tanks occur in the same manner as fitting losses from internal floating roof tanks: through the penetrations in the floating roof deck. As mentioned earlier, these fittings are necessary for the normal operation of the external floating roof. However, these fitting losses can be controlled with gasketing and sealing techniques or by the substitution of a lower emitting fitting type that serves the same purpose. Table 4-5 lists the fitting types that are pertinent to emissions and an abbreviated description of the equipment that is considered to be representative of "uncontrolled" fittings and "controlled" fittings. Certain fitting types are not amenable to control and are not listed in Table 4-5.

4.4.2 Controls for Withdrawal Losses

Withdrawal losses in external floating roof tanks, as with internal floating roof tanks, are entirely a function of the turnover rate and inherent tank shell characteristics. No applicable control measures have been identified to reduce withdrawal losses from floating roof tanks.

TABLE 4-5. "CONTROLLED" AND "UNCONTROLLED" EXTERNAL FLOATING ROOF DECK FITTINGS^{a,2}

Deck fitting type	Equipment descriptions	
	Uncontrolled	Controlled
1. Access hatch	Unbolted, ungasketed cover; or unbolted, gasketed cover	Bolted, gasketed cover*
2. Gauge float in well	Unbolted, ungasketed cover; or unbolted, gasketed cover	Bolted, gasketed cover
3. Guide pole/sample well**	Unslotted pipe-ungasketed sliding cover with or without float; or unslotted pipe-sliding cover, ungasketed*	Unslotted pipe-sliding cover, gasketed
4. Sample well	Weighted mechanical actuation, ungasketed	Weighted mechanical actuation, gasketed*
5. Vacuum breaker	Weighted mechanical actuation, ungasketed	Weighted mechanical actuation, gasketed*
6. Roof drain	Open*	90% closed
7. Rim vent ^b	Weighted mechanical actuation, ungasketed	Weighted mechanical actuation, gasketed*

*The fittings assumed in the uncontrolled case for estimating the effectiveness of fittings controls are marked with a single asterisk in the above table. This fittings scenario is representative of no single tank, but rather is the composite of what is estimated based on a survey of users and manufacturers to be typical of fittings on the majority of tanks currently in service.

**Slotted gauge poles are not addressed because they are not typically used on external floating roof tanks.²

^aExternal floating roof tanks can be converted to an internal floating roof tank by retrofitting with a self-supporting fixed roof which would provide additional emission reductions.

^bRim vents are only used with mechanical shoe primary seals.

4.4.3 Controls For Rim or Seal Losses

Rim seal losses from external floating roof tanks vary depending on the type of seal system employed. As with internal floating roof rim seal systems, the location of the seal (i.e., vapor- or liquid-mounted) is the most important factor affecting the effectiveness of resilient seals for external floating roof tanks. Liquid-mounted seals are more effective than vapor-mounted seals at reducing rim seal losses. Metallic shoe seals, which commonly are employed on external floating roof tanks, are more effective than vapor-mounted resilient seals but less effective than liquid-mounted resilient seals.

The relative effectiveness of the various types of seals can be evaluated by analyzing the seal factors (K_R factor and wind velocity exponent, N) contained in Table 3-2 of the previous chapter. These seal factors were developed on the basis of emission tests conducted on a pilot-scale tank. The results of the emission tests are published in an American Petroleum Institute bulletin.² To compare the relative effectiveness of the alternate seal systems, the seal factors were used with an assumed wind velocity (10 miles per hour) to generate directly comparable emission factors. These factors, which have meaning only in comparison to one another, are listed in Table 4-6 for alternative seal systems. From the information in Table 4-6, it is clear that vapor-mounted primary seals on external floating roof tanks are significantly less effective than liquid-mounted or metallic shoe primary seals. Further, secondary seals provide an additional measure of control. Retrofitting an external floating roof tank with a self-supporting fixed roof would convert the tank to an internal floating roof tank and eliminate the wind influence thereby reducing the rim seal losses.

4.5 VAPOR CONTROL OR RECOVERY SYSTEMS ON FIXED ROOF TANKS

Losses from fixed roof tanks can be reduced by collecting the vapors and either recovering or oxidizing the VOC. In a typical vapor control system, vapors remain in the tank until the internal pressure reaches a preset level. A pressure switch, which senses the pressure buildup in the tank, then activates

TABLE 4-6. EXTERNAL FLOATING ROOF TANK SEAL SYSTEM CONTROL EFFICIENCIES^{a, b}

Seal system description	Emissions factor, ^a (10) ^N 6K _R	Seal loss control efficiency ^c
Vapor-mounted resilient primary seal only	239	EFR baseline (0%)
Vapor-mounted resilient primary seal and secondary seal	80	66%
Metallic shoe primary seal only	38	84%
Metallic shoe primary seal with a shoe-mounted wiper seal	13	95%
Liquid-mounted resilient primary seal only	11	95%
Metallic shoe primary seal with rim-mounted secondary seal	2.0	99%
Liquid-mounted resilient primary seal with rim-mounted secondary seal	1.8	99%

^aFor well designed seal systems with "average" gaps between the seal and the tank shell. Calculated from K_R and N values listed in Table 3-2.

^bExternal floating roof tanks can be converted to an internal floating roof tank by retrofitting with a self-supporting fixed roof. This would eliminate wind influences thereby reducing rim seal losses.

^cRim seal loss control efficiency relative to the least effective seal alternative.

blowers to collect and transfer the vapors through a closed vent system. A redundant blower system may be provided in this service to ensure that no vapors will be released to the atmosphere in the event of a primary blower malfunction. The closed vent system ducts the vapors to a recovery or oxidizer unit.

To prevent flashbacks from the control equipment, systems can be designed to operate so that vapor levels are above the upper explosive limit, enriched with natural gas to 1.2 times the upper explosive limit (21 percent), or inerted with nitrogen or inert flue gas. Other safety precautions are also exercised such as nitrogen blanketing and using flame arrestors. The particular precautions employed vary widely depending on the design of individual systems and the operating preference of individual companies.

4.5.1 Carbon Adsorption

Although there is little commercial operating experience for VOL applications of carbon adsorption, carbon adsorption has been demonstrated in the recovery of other organic vapors, and applying this technology to VOL recovery should not be difficult.³ Application of this vapor control technology, however, is probably more widespread in the chemical industry than in the petroleum industry. The general principle of adsorption is described below to facilitate the description of a carbon adsorption unit.

Carbon adsorption uses the principle of carbon's affinity for nonpolar hydrocarbons to remove VOC's from the vapor phase. Activated carbon is the adsorbent; the VOC vapor that is removed from the airstream is referred to as the adsorbate. The VOC vapor is adsorbed by a physical process at the surface of the adsorbent. The VOC carbon adsorption unit consists of a minimum of two carbon beds plus a regeneration system. Two or more beds are necessary to ensure that one bed will be available for use while the other is being regenerated.

The carbon beds can be regenerated using either steam or vacuum. In steam regeneration, steam is circulated through the

bed, raising the VOC vapor pressure. The vaporized VOC is then removed from the steam: the steam-VOC mixture is condensed, usually by an indirect cooling water stream, and routed to a separator. The VOL is then decanted and returned to storage, and the contaminated water is sent to the plant wastewater system for treatment. Cooling water, electricity, and steam are the required utilities for a steam regeneration system. The other method of regenerating the carbon, vacuum regeneration, is performed by pulling a high vacuum on the carbon bed. The VOC vapor desorbed by this process is condensed and returned to storage.

4.5.2 Oxidation Units

Thermal and catalytic oxidizers have been used successfully to dispose of VOC vapors in other industries. Thermal oxidation is the most direct means of VOC vapor disposal and uses the fewest moving parts. The vapor mixture is injected via a burner manifold into the combustion area of the incinerator. Pilot burners provide the ignition source, and supplementally fueled burners add heat when required. The amount of combustion air needed is regulated by temperature-controlled dampers. A water-seal flame arrestor can be used to ensure that flashbacks do not spread from the burner to the rest of the closed vent system. As mentioned, safety practices and equipment vary widely depending on system design and the operating preference of individual companies. A significant advantage of thermal oxidizers is that they can dispose of a wide range of VOC's. Fuel consumption and catalyst replacement are the major cost factors in considering thermal and catalytic oxidation.

4.5.3 Refrigerated Vent Condensers

A refrigerated vent condenser collects the VOL vapors exiting through the vents and condenses them. The vents open and close as the pressure within the tank increases and decreases. Pressure changes occur when the tank is being filled or emptied or when the temperature changes. Condensers should be designed to handle the maximum flow rate expected at any given time, which usually occurs during filling. Freezing of moisture is handled

by a defrost-separation-recovery system. The efficiency of vent condensers depends upon the vapor concentration and the condensing temperature.

4.5.4 Control Efficiencies of Vapor Recovery or Control Systems

The carbon adsorption vapor control system is estimated to reduce emissions from the VOL storage vessel by approximately 95 percent or greater. This efficiency is based on a measured carbon adsorption unit efficiency of 98 percent during gasoline loading operations.⁴

The refrigerated vent condenser is capable of achieving emission reductions of greater than 90 percent from VOL storage vessels. However, as explained in the previous section, the condenser efficiency depends on the vapor concentration of the emission stream and the designed condensation temperature.

The thermal oxidation vapor control system is capable of achieving emission reductions of 98 percent or greater from VOL storage vessels. This efficiency is based on a measured thermal oxidation unit efficiency of 98 percent during a wide variety of operations.^{5,6} At very low flow rates or at low VOC inlet concentrations, somewhat less than 98 percent of the VOC vapors leaving the storage vessel may be incinerated.

4.6 RETROFIT CONSIDERATIONS

This section discusses possible considerations that owners and operators may have in retrofitting their tanks with alternative design equipment. Prior to retrofit construction, tank owners will have to schedule time for the tank to be out of service. The tank and roof must then be cleaned and degassed before workers may enter the tank to begin retrofitting.

4.6.1 Fixed Roof Tanks With Internal Floating Roofs

Several modifications may be necessary on a fixed roof tank before it can be equipped with an internal floating roof. Tank shell deformations and obstructions may require correction, and special structural modifications such as bracing, reinforcing, and plumbing vertical columns may be necessary. Antirotational guides should be installed to keep floating roof openings in alignment with fixed roof openings.●

Special vents may be installed on the fixed roof or on the walls at the top of the shell to minimize the possibility of VOL vapors approaching the explosive range in the vapor space. Alternatively, other fire protection devices such as flame arresters may be provided instead of circulation vents.

4.6.2 Secondary Seals on Existing Internal Floating Roofs

Retrofitting problems may be encountered when installing a secondary seal on a noncontact internal floating roof. Unlike some contact internal floating roofs, the noncontact internal floating roof generally does not have an outer rim on which to attach a secondary seal. Extensive modifications to the noncontact internal floating roof may be required in order to install a secondary seal. This problem may also occur on some designs of contact internal floating roofs. Additional rim flotation may be required when retrofitting a secondary seal on a contact or noncontact internal floating roof to ensure that the roof will remain buoyant with the additional weight of the secondary seal.

4.6.3 Liquid-Mounted Seals on Existing Internal Floating Roofs

Liquid-mounted seals are generally heavier and exert more compressive force than vapor-mounted seals, particularly wiper-type seals. When retrofitting existing internal floating roofs, rim flotation may become a problem, particularly in the noncontact-type designs. The heavier seal may cause the rim of the noncontact deck to sink below the liquid surface.

4.6.4 Rim-Mounted Secondary Seals on External Floating Roofs

Retrofitting problems may be encountered when a secondary seal is installed above a primary seal. Some primary seals are designed to accommodate a large amount of gap between the primary seal and the tank wall. Some secondary seals may not be able to span as large a gap, and, consequently, excessive gaps may result between the secondary seal and the tank shell. When adding a secondary seal it is not always necessary to degas the tank because there is typically a predrilled horizontal flange on which the seal can be attached.⁷ However, if the flange has to be repaired or modified to be able to properly mount the

secondary seal, this may require hot work and the tank should be cleaned and degassed prior to the installation.

4.6.5 Self-Supporting Fixed Roofs on External Floating Roof Tanks

Several design issues are encountered in the retrofit of a self-supporting fixed roof to an existing open top tank. For example, the weight of the fixed roof produces localized loading on the tank. The self-supporting fixed roofs are typically made of aluminum, which results in the potential for differential movement between the aluminum fixed roof and the steel tank shell due to the difference in their coefficients of thermal expansion.

4.7 PROBLEM LIQUIDS AND MATERIALS OF CONSTRUCTION

Many liquids such as chlorinated organic solvents cannot utilize the same control technologies previously mentioned. These problem liquids are corrosive in nature and may degrade certain metals as well as seal materials. For problem liquids that corrode aluminum, a welded steel floating roof with a specialty seal that can withstand attack by the liquid can be used to reduce emissions. If the liquid is too corrosive to utilize a welded-steel floating roof or specialty seal, or is stored in a fiberglass fixed roof tank, an applicable control technology is to vent emissions to an add-on pollution control device such as an incinerator or a stainless steel condenser.

4.8 REFERENCES

1. The American Petroleum Institute. Evaporative Loss From Internal Floating-Roof Tanks. API Publication 2519, Third Edition. June 1982.
2. The American Petroleum Institute. Evaporative Loss From External Floating-Roof Tanks. API Publication No. 2517, Third Edition. February 1989.
3. U. S. Environmental Protection Agency. Evaluation of Control Technology From Benzene Transfer Operations. Research Triangle Park, NC. EPA-450/3-78-018. April 1978.
4. Letter from McLaughlin, N., EPA, to D. Ailor, TRW Inc. May 3, 1979. Comments on the benzene storage model plant package.
5. Letter and attachments from Mascone, D. EPA/CPB, to Farmer, J. EPA/OAQPS. June 11, 1980. Memo concerning thermal incinerator performance for NSPS.
6. U. S. Environmental Protection Agency. Organic Chemical Manufacturing, Volume 4: Combustion Control Devices. Research Triangle Park, NC. Publication No. EPA-450/3-80-026. December 1980.
7. Telecon. deOlloqui, V., MRI with Moffit, L. Pittsburgh-Des Moines Corp. Discussion about retrofitting a secondary seal on an external floating roof tank. June 26, 1991.



5.0 ENVIRONMENTAL IMPACTS OF CONTROL OPTIONS

5.1 ENVIRONMENTAL IMPACTS

Two types of environmental impacts result from controlling VOL storage tanks: (1) impacts from reducing VOC emissions from the tank and (2) secondary impacts from implementing the control options. The secondary impacts result from cleaning and degassing the tank prior to installing some types of equipment such as an internal floating roof or replacing a primary seal.

Impacts were developed for model tanks (defined in Chapter 3) by analyzing the control options applicable to fixed-roof, internal floating roof, and external floating roof tanks described in Chapter 4. Nationwide emissions estimates and tank populations for each tank type were estimated from information developed in the 1984 background information document for VOL storage tanks.¹ Nationwide secondary environmental impacts for each tank type were estimated by determining the secondary impacts of the control options for a typical size model tank, then multiplying the impacts for this tank by the estimated number of tanks affected at the stored liquid vapor pressure and tank capacity cutoffs of each specific control option. The following sections present the model tank and nationwide environmental impacts of each control option.

5.2 FIXED ROOF MODEL TANKS

Control equipment for fixed roof model tanks is described in Chapter 4, Section 4.2. The control equipment hierarchies outlined in Table 4-1 were organized into control options. Specific options considered include:

1. A bolted construction internal floating roof with a vapor-mounted primary seal and uncontrolled fittings (Option I);

2. A bolted construction internal floating roof with a vapor-mounted primary and secondary seals with controlled fittings (Option II);

3. A bolted construction internal floating roof with a liquid-mounted primary and secondary seals with controlled fittings (Option III); or

4. A welded construction internal floating roof (steel pan or fiberglass-reinforced plastic [FRP] deck) with a liquid-mounted primary and secondary seals with controlled fittings (Option IV).

5.2.1 Emissions Reductions

These control options were applied to the model tanks described in Chapter 3 and emissions profiles were generated. Figure 5-1 presents the VOC emissions from the model fixed-roof tanks greater than 151,420 liters (L) (40,000 gallons [gal]) storing a model VOL at vapor pressures of 3.4, 5.2, and 6.9 kiloPascals (kPa) [0.5, 0.75 and 1 pound per square inch absolute (psia)] at 10 and 50 turnovers per year. Figure 5-1 shows that fixed roof tank emissions increase significantly with an increase in turnovers or an increase in vapor pressure. Figure 5-2 presents model tank emissions for the same tank capacities, vapor pressures, and turnovers as Figure 5-1 but for a model crude oil. A comparison of the VOC emissions from the model VOL and crude oil tanks at the same turnover rates and vapor pressures shows that the model crude oil tanks emit less VOC than the model VOL tanks.

The effect of the control options on fixed-roof tank emissions is shown in Figure 5-3. This figure shows that for 50 turnovers per year and an absolute liquid vapor pressure of 6.9 kPa (1.0 psia), the installation of a basic internal floating roof provides a significant emission reduction for fixed-roof tanks. However, applying additional controls to the internal floating roof such as controlling fittings or adding a secondary seal does not provide any significant emission reduction beyond that achieved by the installation of the internal floating roof.

Figures 5-4 and 5-5 present emissions for Options I - V at 10 and 50 turnovers per year. A comparison of these figures shows that the turnover rate does not significantly effect emissions from internal floating roof tanks, which is opposite from that shown in Figure 5-2 for fixed-roof tanks where the turnover rate significantly effects emissions. Therefore, the working or withdrawal losses, which are dependent upon the turnover rate or throughput, account for a significantly larger percentage of emissions from a fixed-roof tank than an internal floating roof tank.

Figures 5-4 and 5-5 also present the incremental emission reductions achieved by Options II through V beyond that achieved by Option I, the installation of an internal floating roof. The data presented in these figures reaffirms that the incremental emission reduction achieved by additional controls is small compared to the emission reduction achieved by the installation of the internal floating roof.

For fixed-roof tanks with capacities ranging from 75,700 to 151,420 L (20,000 to 40,000 gal), the same control options apply as those shown in Figures 5-4 and 5-5 and the effects of the control options on emissions are similar. However, for fixed-roof tanks less than 75,700 L (20,000 gal), the only control option examined was the installation of a condenser with a required control efficiency of 90 percent. This was the only control option examined because most storage tanks below 75,700 L (20,000 gal) are horizontal rather than vertical tanks and a large percentage of these tanks are also underground; therefore, the installation of internal floating roofs is not practical.

5.2.2 Secondary Impacts

Secondary impacts are those impacts not directly associated with the VOC emission reductions described in the preceding section, but rather those with implementing the control option. The following sections describe the secondary environmental impacts associated with implementing the control options for fixed-roof tanks.

5.2.2.1 VOC Emissions from Degassing and Sludge Handling.

Prior to installing an internal floating roof in a fixed-roof tank, the tank needs to be cleaned and degassed. Cleaning and degassing is necessary to allow the tank to be modified to install an internal floating roof and to allow workers to enter the tank. The degassing emissions are those emissions that will be released from the tanks' vapor space prior to cleaning, and sludge handling emissions are released from the tank in the process of removing sludge from the tank during cleaning. Sludge handling emissions are difficult to quantify because they depend entirely on the care the tank service company takes in removing the sludge from the tank.

Emission estimates for degassing and sludge handling were estimated based on the quantities of rinseate required to clean the tank and the amount of residual sludge in the bottom of the tank. Estimates obtained from a tank service company indicate that 7,570 L (2,000 gal) of sludge and 3,790 L (1,000 gal) of rinseate would result from cleaning a 757,000 L (200,000 gal) tank.² Based on these values, it was estimated that 1 Mg (1.1 ton) of VOC emissions are released during degassing of the tank. Additional VOC emissions could be released during the sludge handling operations but the quantity of these emissions is unknown.

5.2.2.2 Solid and Hazardous Waste.

Another possible source of secondary emissions is the treatment, storage or disposal of tank sludges and the rinseate used to clean the tank. The exact regulatory status of the sludge and rinseate will be a function of the contents of the tank and the properties of these materials.

The sludge generated from the tank cleaning process could be up to 90 percent liquid. Independent of any VOC emitted from the liquid portion of the sludge, 11,360 L (3,000 gal) of solid waste will be produced from cleaning a 757,000 L (200,000 gal) tank. This material may be industrial solid waste regulated under provisions authorized by Subtitle D of RCRA; or alternatively it may be a hazardous waste in which case treatment, storage, and

disposal of this material would be regulated in accord with regulations authorized by Subtitle C of RCRA. To the extent that these materials are hazardous wastes, RCRA regulations would require reduction of secondary emissions by prohibiting the use of high emitting treatment, storage, and disposal techniques, such as the use of land farming. Furthermore, secondary emissions would be reduced by limiting emissions from other types of treatment, storage, and disposal techniques. A variety of methods such as incineration are available to treat, store, and dispose of hazardous waste sludge. If a facility were to incinerate the sludge, there would potentially be minimal emissions from the hazardous waste treatment, storage, and disposal. The only emissions would be from degassing and sludge handling. However, if a facility were to landfarm a Subtitle D (nonhazardous) waste, virtually all of the emissions from the sludge might be released to the atmosphere.

5.3 INTERNAL FLOATING ROOF TANKS

Control options for internal floating roof tanks are almost identical to the control options for fixed-roof tanks and consist of equipping the tank with:

1. A bolted construction internal floating roof with a vapor-mounted primary seal and controlled fittings (Option I);
2. A bolted construction internal floating roof with a vapor-mounted primary and secondary seals with controlled fittings (Option II);
3. A bolted construction internal floating roof with a liquid-mounted primary and secondary seals with controlled fittings (Option III); or
4. A welded construction internal floating roof (steel pan or FRP deck) with a liquid mounted primary and secondary seals with controlled fittings (Option IV).

The baseline internal floating roof tank configuration was assumed to consist of a bolted-construction internal floating roof with a vapor-mounted primary seal.

5.3.1 Emissions Reductions

These control options were applied to the internal floating roof (IFR) model tanks presented in Chapter 3. The VOC emission reduction from the baseline IFR tanks for each emission control option are shown in Figures 5-6 and 5-7 for a model VOL and crude oil, respectively. As stated earlier, VOC emissions from internal floating roof tanks do not depend as much on the number of tank turnovers per year as the liquid vapor pressure and tank capacity. The incremental emissions reductions between increasingly more stringent control options is relatively small ranging from 5 to 20 kilograms (kg) [11 to 44 pounds (lb)].

5.3.2 Secondary Impacts

5.3.2.1 VOC Emissions from Degassing and Sludge Handling.

All of the control options for internal floating roof tanks require cleaning and degassing the tank. Therefore, these emissions will have to be considered when applying these control options. Referring to the emissions estimates developed for a 757,000 L (200,000 gal) tank in Section 5.2.2, 1 Mg (1.1 ton) may be released from degassing the tank. Depending on the method of disposal, the sum of the cleaning and degassing emissions may be greater than the emission reductions obtained from the implementation of the control options (<1 Mg [1.1 ton]). For this reason, it may be necessary to minimize the environmental impacts associated with cleaning and degassing by requiring internal floating roof tanks to implement the control options when the tanks are out of service for their regularly scheduled cleaning.

5.3.2.2 Hazardous Waste. The amount of hazardous waste generated from disposing of the tank sludge and rinseate is equivalent to that from fixed-roof tanks. Again, the method of treatment, storage, and disposal of the waste is the determining factor as to the quantity of VOC emitted to the atmosphere.

5.4 EXTERNAL FLOATING ROOF TANKS

Control equipment for external floating roof tanks is discussed in Chapter 4, and the control options are described in Table 4-2. The control option for an external floating roof

(EFR) tank equipped with a mechanical shoe primary seal consists of adding a secondary seal and controlling fittings. Two control options exist for an EFR tank equipped with a vapor-mounted primary seal only; (1) adding a secondary seal and controlling fittings, and (2) replacing the vapor-mounted primary seal with a liquid-mounted primary seal, adding a secondary seal, and controlling fittings.

5.4.1 Emissions Reductions

The control options presented above were applied to the model tanks described in Chapter 3. The emissions for the two baseline EFR tank configurations and the corresponding control option(s) are shown in Figures 5-8 and 5-9, respectively. From Figure 5-8 it is shown that the greatest emission reduction for a baseline external floating roof tank with metallic shoe primary seal is obtained from the addition of a secondary seal and controlled fittings. From Figure 5-9 it is shown that the greatest emission reduction for a baseline external floating roof tank with a vapor-mounted primary seal is obtained by the substitution of a liquid-mounted primary for the vapor-mounted primary seal in conjunction with the addition of secondary seals and controlled fittings.

5.4.2 Secondary Impacts

5.4.2.1 VOC Emissions from Degassing and Sludge Handling.

In order to install a secondary seal in an external floating roof tank, a tank may not always have to be cleaned and degassed. This is because the external floating roof tanks are typically equipped with a flange on which the secondary seal can be bolted.³ This may eliminate the need for cutting, welding, or drilling; therefore, there may be no need to clean and degas the tank. However, if the flange is in poor condition or if the flange is unsuitable for the installation of a secondary seal, the tank would have to be cleaned and degassed prior to the necessary welding. For the purposes of this ACT, it has been assumed that degassing would be required prior to installing a secondary seal. In addition, no modifications that would require degassing of the tank are needed to control fittings. For

purposes of assessing secondary impacts, the quantity of emissions released from an external floating roof tank as a result of degassing were the same as those described previously for similar sized fixed-roof and internal floating roof tanks.

5.4.2.2 Hazardous Waste. The amount of solid waste generated from treatment, storage, and disposal of the tank sludge and rinseate is equivalent to that from fixed-roof or internal floating roof tanks of a similar size. As stated previously, the disposal method is the determining factor as to the quantity of VOC emitted to the atmosphere as a result of solid waste treatment, storage, and disposal.

5.5 NATIONWIDE IMPACTS OF CONTROL OPTIONS

Nationwide environmental impacts were determined for each of the three tank types and their associated control options. The nationwide number of tanks and the amount of VOC emissions associated with the three tank configurations (fixed, internal floating, and external floating roofs) were estimated by taking the tank population and emissions estimates developed for the Volatile Organic Liquid NSPS and accounting for:

1. Tanks in nonattainment areas;
2. Tanks already regulated by either an existing CTG or NSPS; and
3. Tanks not considered in the specific control option because the tanks were outside the tank capacity and vapor pressure cutoffs of the control options.¹

The tank capacity and vapor pressure cutoffs for each control option were determined based on the combined environmental and cost impacts of these options on a model tank basis. Once the number of affected tanks and the nationwide emissions levels were determined for each option, nationwide secondary impacts were then calculated. Secondary impacts were assessed for a representative tank in each category and multiplied by the number of affected tanks to obtain nationwide impacts:

Tanks in nonattainment areas were determined from industry profiles contained in the 1987 Census of Manufacturers Data and

from a 1991 EPA database of county ozone nonattainment status.⁴ A database was developed from this information that contains the number of facilities by county and standard industry classification (SIC) codes, and includes a classification of each county as an attainment or nonattainment area. The total number of facilities in SIC codes 2911 (petroleum refining), 2861 (gum and wood chemicals), 2865 (cyclic crudes and intermediates), and 2869 (industrial organic chemicals) were then compiled. After compiling these estimates for each industrial segment, the percentages of the facilities located in nonattainment areas was determined. These percentages (about 45 percent for the petroleum industry and about 55 percent for the chemical industry) were then applied to the tank population and emissions estimates previously derived to obtain the base number of affected tanks and emissions levels for each industrial category.

Because the control options were segregated by tank capacity and vapor pressure of the liquid stored in the tank, the base number of tanks and corresponding emissions estimates for each category had to be apportioned in a similar manner. Tank population data apportioned by tank capacity and vapor pressure was available to a limited extent. However, this information was insufficient to apportion the tank population into the narrow tank capacity and vapor pressure ranges required by the control options. For example, tank population data was available for tanks storing liquids in the vapor pressure range of 3.4 to 6.9 kPa (0.5 to 1.0 psia) at various tank capacity cutoffs. However, the vapor pressure cutoffs required an estimate of the tank population in the vapor pressure ranges from 3.4 to 5.2 kPa (0.5 to 0.75 psia) and 5.2 to 6.9 kPa (0.75 to 1.0 psia). Therefore, it was assumed that the number of affected tanks within the broader vapor pressure ranges were distributed equally across the range. Using this approach, if 1,000 tanks were within the broad range of 3.4 to 6.9 kPa (0.5 to 1.0 psia), then 500 tanks were assumed to be in the range from 3.4 to 5.2 kPa (0.5 to 0.75 psia) and 500 tanks in the range from 5.2 to 6.9 kPa

(0.75 to 1.0 psia). However, nationwide emissions estimates from these tanks were apportioned into smaller vapor pressure ranges according to ratios developed between the emissions levels and the vapor pressure function, so that as the vapor pressure increased the emissions estimates increased.

5.5.1 Fixed-Roof Tanks

The representative tank used to develop nationwide secondary impacts for fixed-roof tanks was a 4.9 million liter (1.3 million gallon) tank with a diameter of about 20 meters (m) (60 feet [ft]) and a height of 15 m (48 ft). The model liquid used to determine nationwide impacts is jet naphtha that has the following properties: (1) a molecular weight of 80 grams per gram-mole (80 pounds per pound-mole); (2) a density of 0.72 kilograms per liter (kg/L) (6 pounds per gallon (6 lb/gal)); and (3) a product recovery factor of 350 dollars per megagram (\$/Mg) (320 dollars per ton [\$/ton]).

The nationwide impacts for fixed-roof tank control options are presented in Table 5-1 and are listed from least to most stringent. The total number of affected tanks estimated at the vapor pressure cutoffs of 3.4, 5.2, 6.9 kPa (0.5, 0.75, 1.0 psia) is 3,000, 2,300, and 1,700 tanks, respectively. Of these totals, approximately 70 to 75 percent are storing petroleum products and the remaining 25 to 30 percent are storing organic chemical products.

5.5.2 Internal Floating Roof Tanks

The representative internal floating roof tank was the same size as that of the representative fixed-roof tank. This representative tank is also storing the same model liquid as the representative fixed-roof tank. The nationwide impacts for internal floating roof tank control options is presented in Tables 5-2 and 5-3. The total number of affected tanks estimated at the vapor pressure cutoffs of 3.4, 5.6, 6.9, and 10.3 kPa (0.5, 0.75, 1.0, and 1.5 psia) is 6,000, 5,800, 5,600, and 5,500, respectively. Of these totals, approximately 75 percent are storing petroleum products and the remaining 25 percent are storing organic chemical products.

The nationwide secondary environmental impacts for internal floating roof tank options presented in Table 5-3 are provided for informational purposes only. In implementing these control options, the required control equipment would not be installed until the IFR tanks are degassed and cleaned during the next normal maintenance period for the tanks.

5.5.3 External Floating Roof Tanks

Neither nationwide emissions estimates nor secondary impacts could be quantified for external floating roof tanks because no data was available that could be used to determine the number of tanks in each vapor pressure range according to seal type. However, the nationwide emission reductions obtained from applying secondary seals and controlling fittings could be approximated based on the number of EFR tanks. At vapor pressure cutoffs of 3.4, 5.2, 6.9, and 10.3 kPa (0.5, 0.75, 1.0, and 1.5 psia) and greater and tank capacity cutoffs of 151,420 L (40,000 gal) and greater at each vapor pressure, the estimated nationwide emission reductions are 9,390, 9,260, 9,060, and 8,210 Mg/yr (10,330, 10,180, 9,960, and 9,030 tons/yr), respectively. The estimated number of affected tanks at these same vapor pressure cutoffs is estimated at 6,600, 6,400, 6,300, and 6,000, respectively.

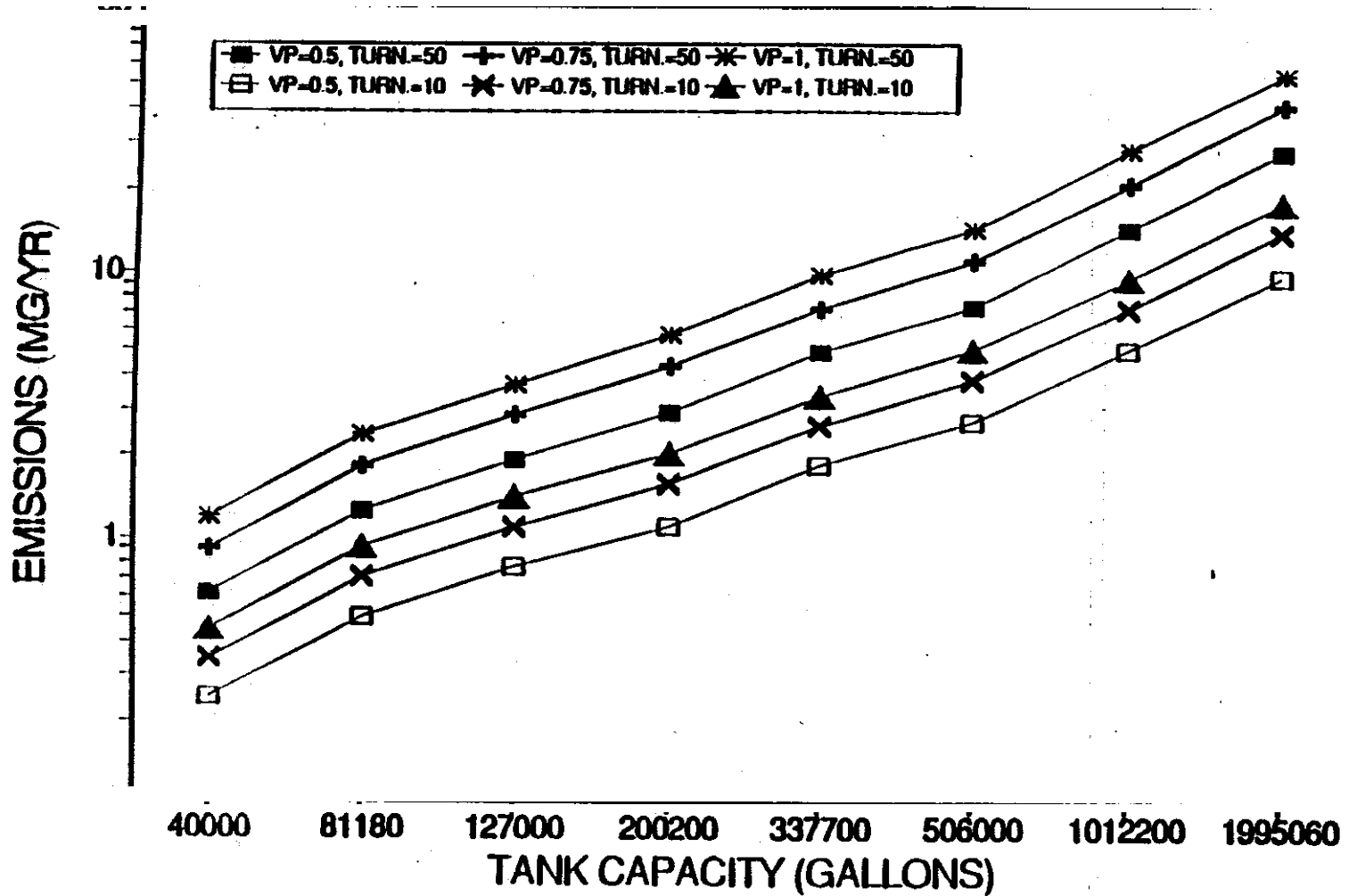

Figure 5-1. The effects of turnover rates and stored liquid vapor pressure on emissions from fixed-roof tanks storing a model VOL.

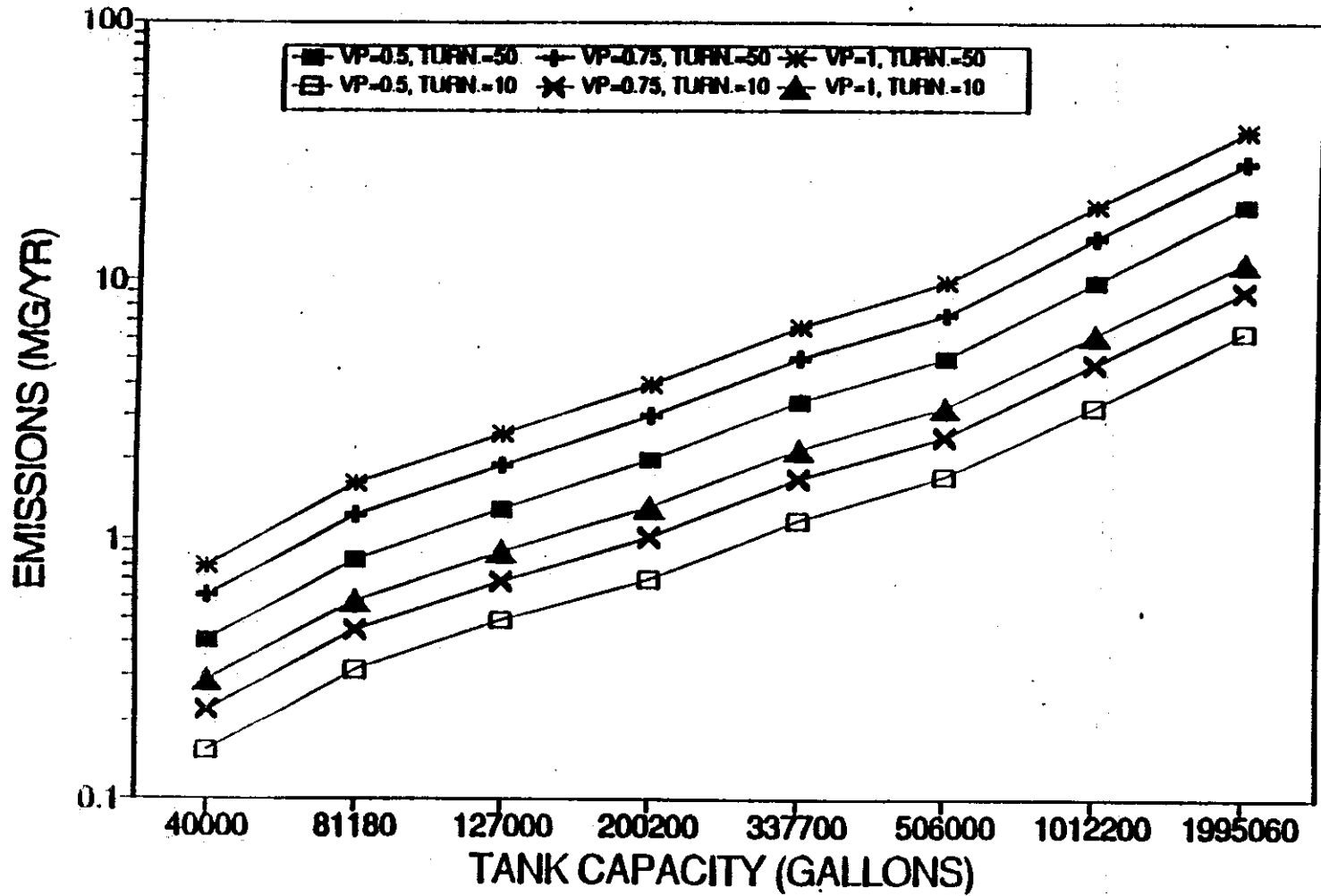

Figure 5-2. The effects of turnover rates and stored liquid vapor pressure on emissions from fixed-roof tanks storing a model crude oil.

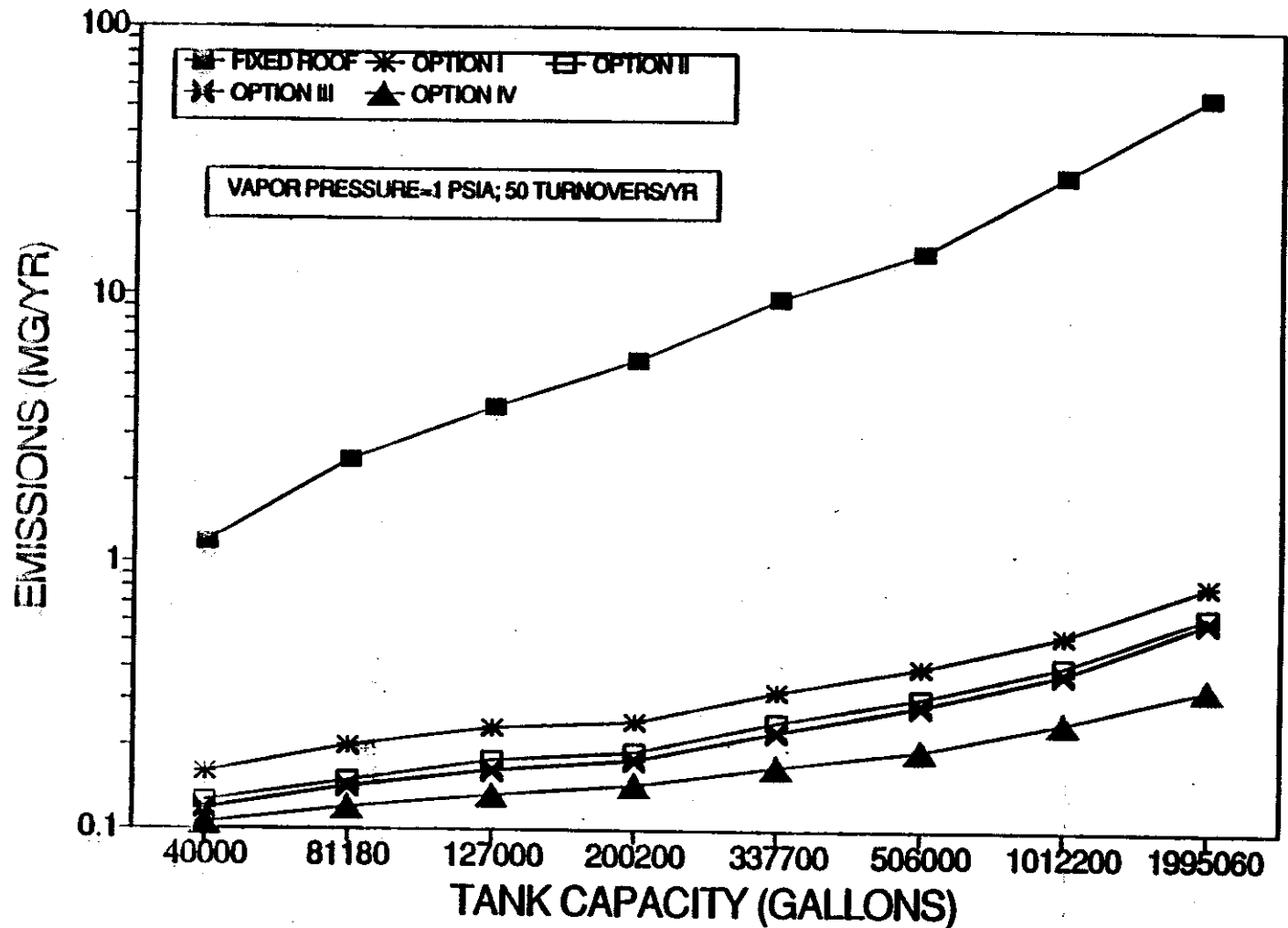

Figure 5-3. The effect of the control options on emissions from fixed-roof tanks storing VOL as a function of tank volume.

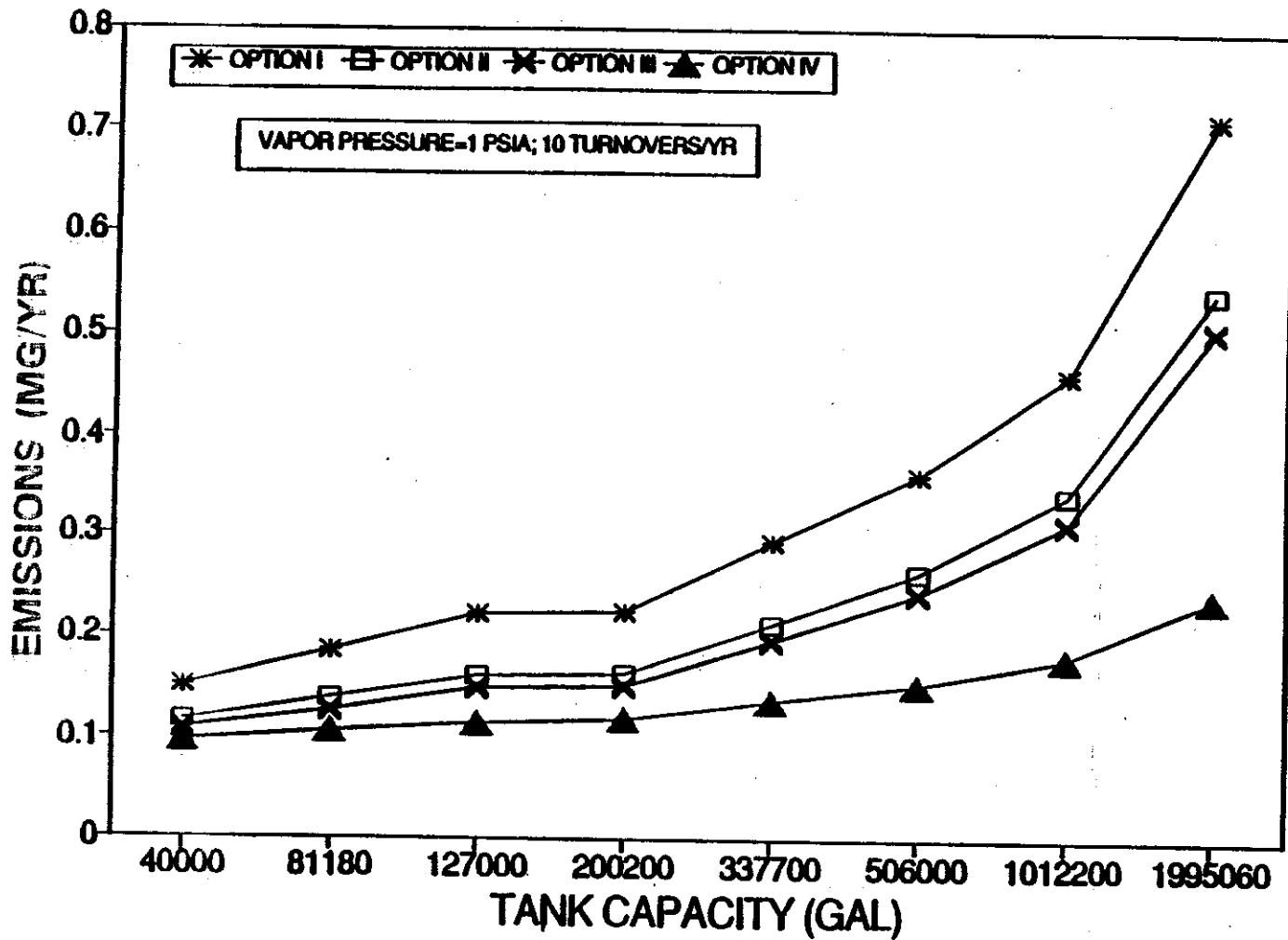

Figure 5-4. The effect of the control options on emissions from fixed-roof tanks storing VOL as a function of tank volume.

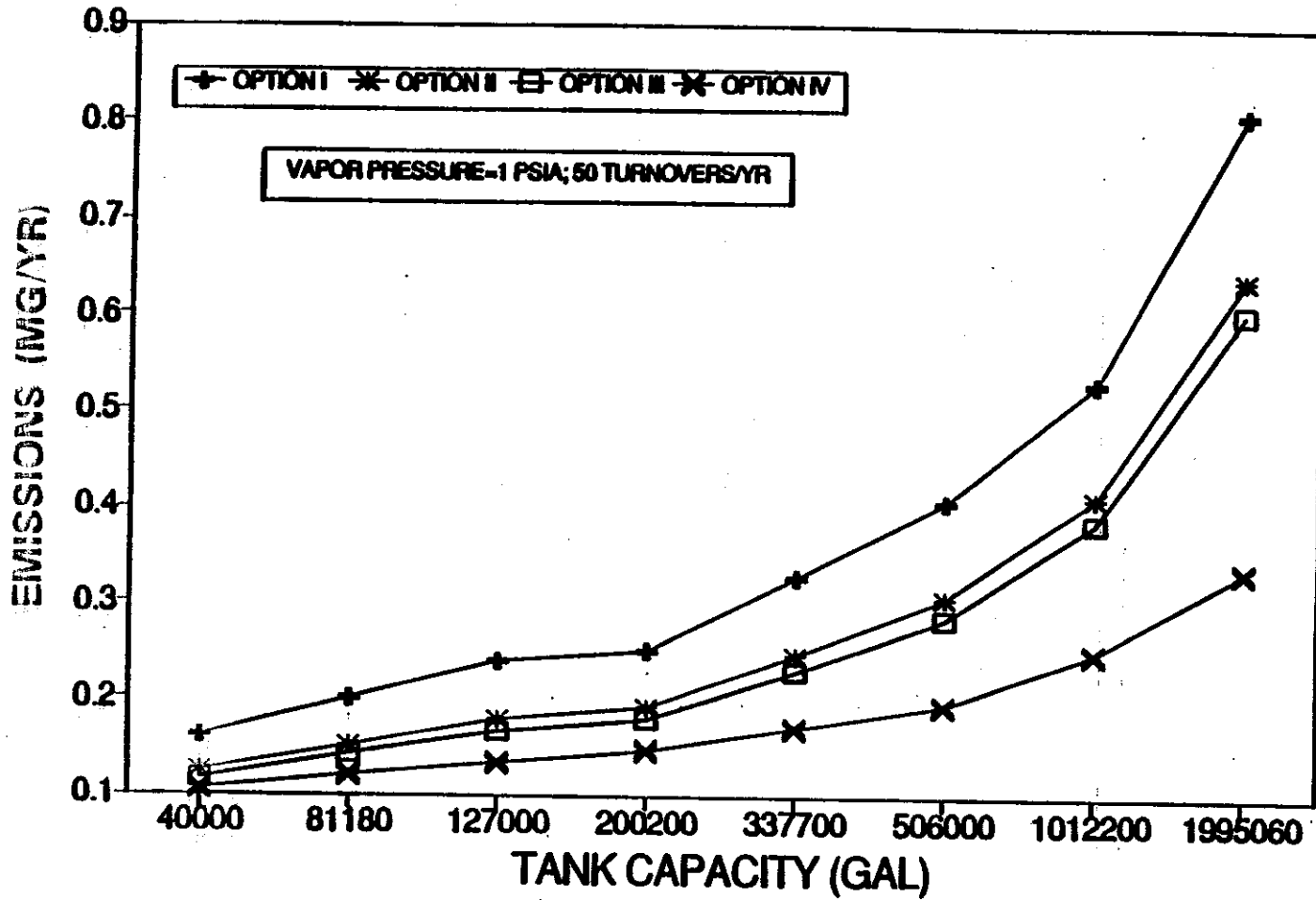

Figure 5-5. The effect of the control options on emissions from fixed-roof tanks storing VOL as a function of tank volume.

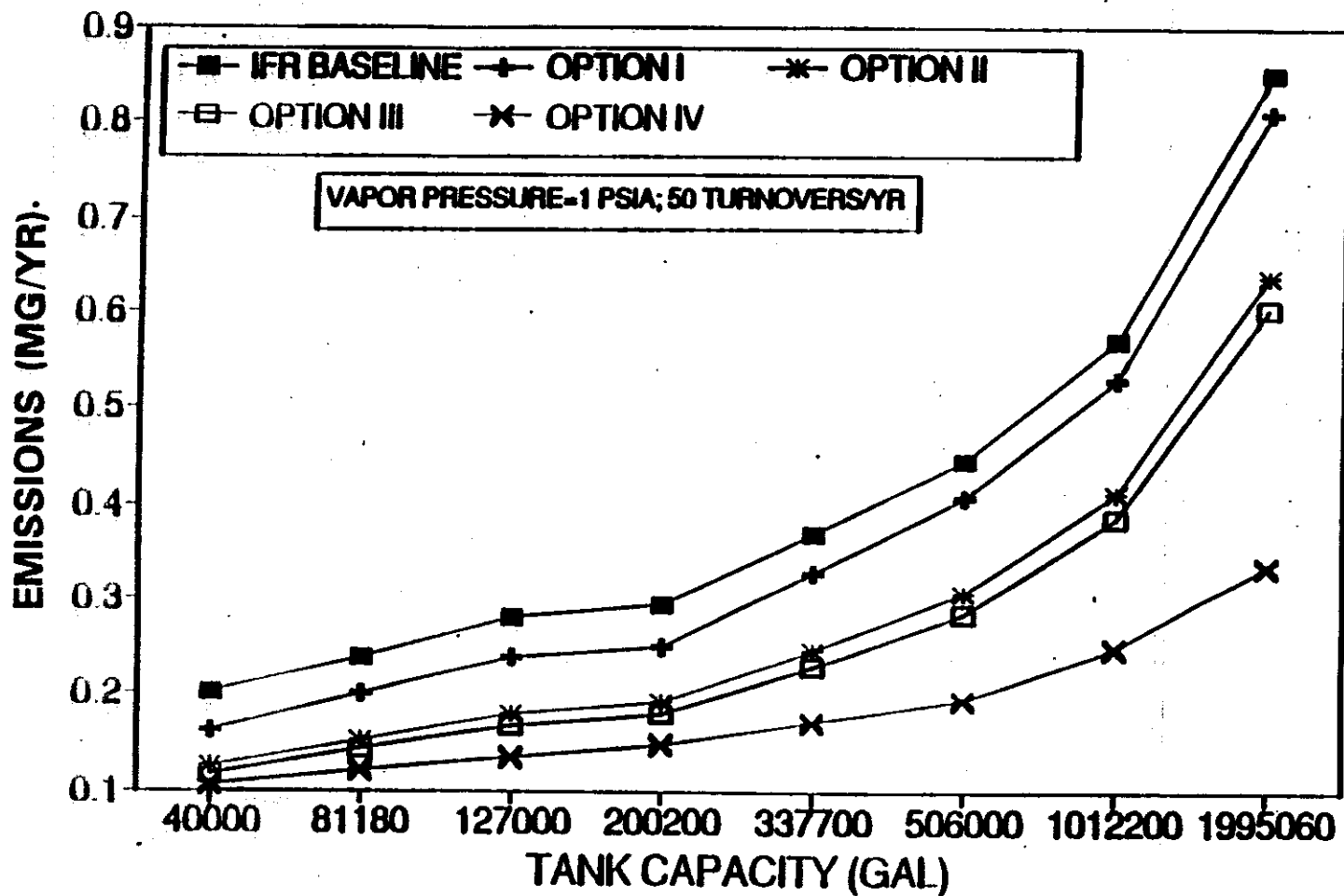

Figure 5-6. The effect of the control options on emissions from internal floating roof tanks storing VOL as a function of tank volume.

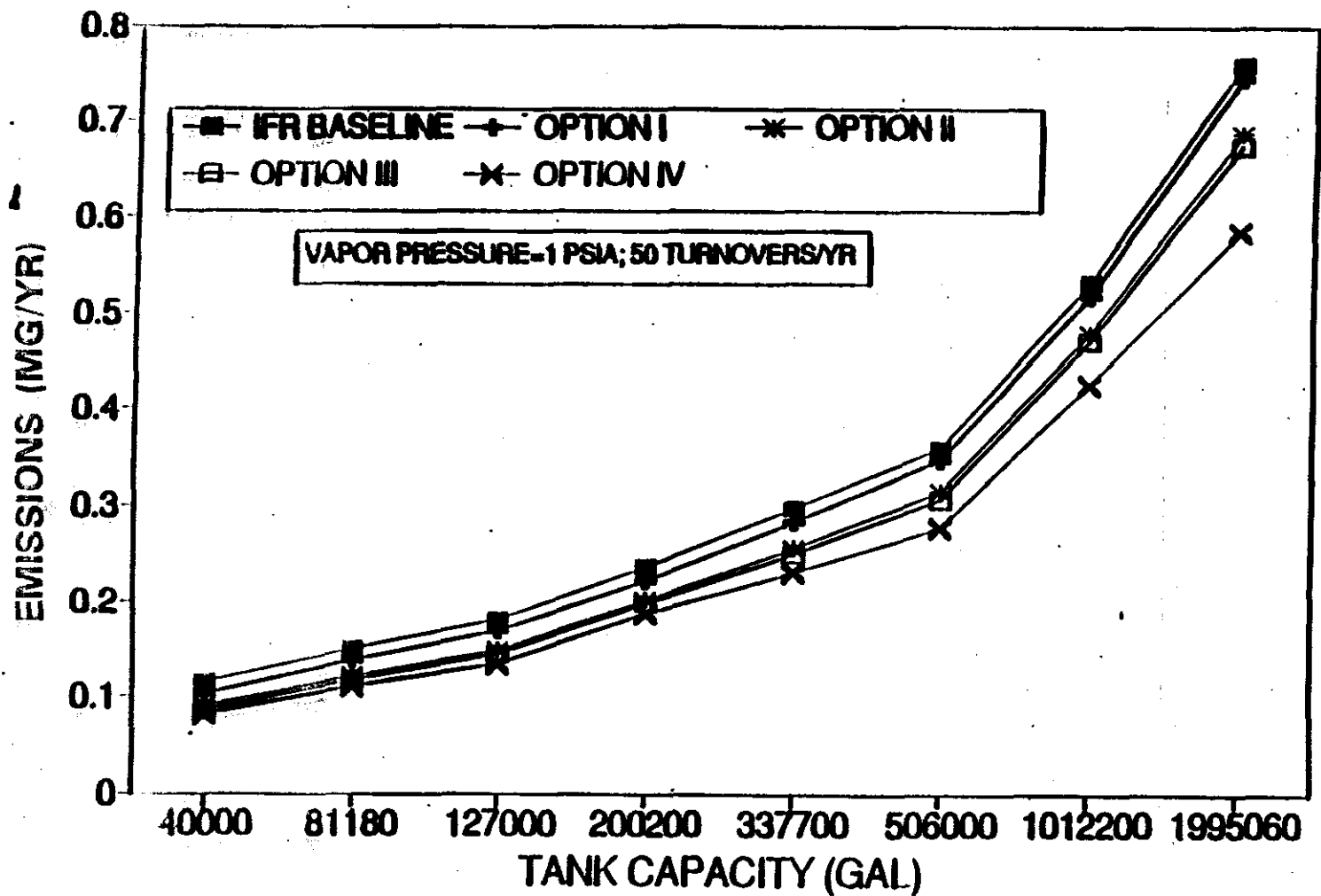

Figure 5-7. The effect of the control options on emissions from internal floating roof tanks storing crude oil as a function of tank volume.

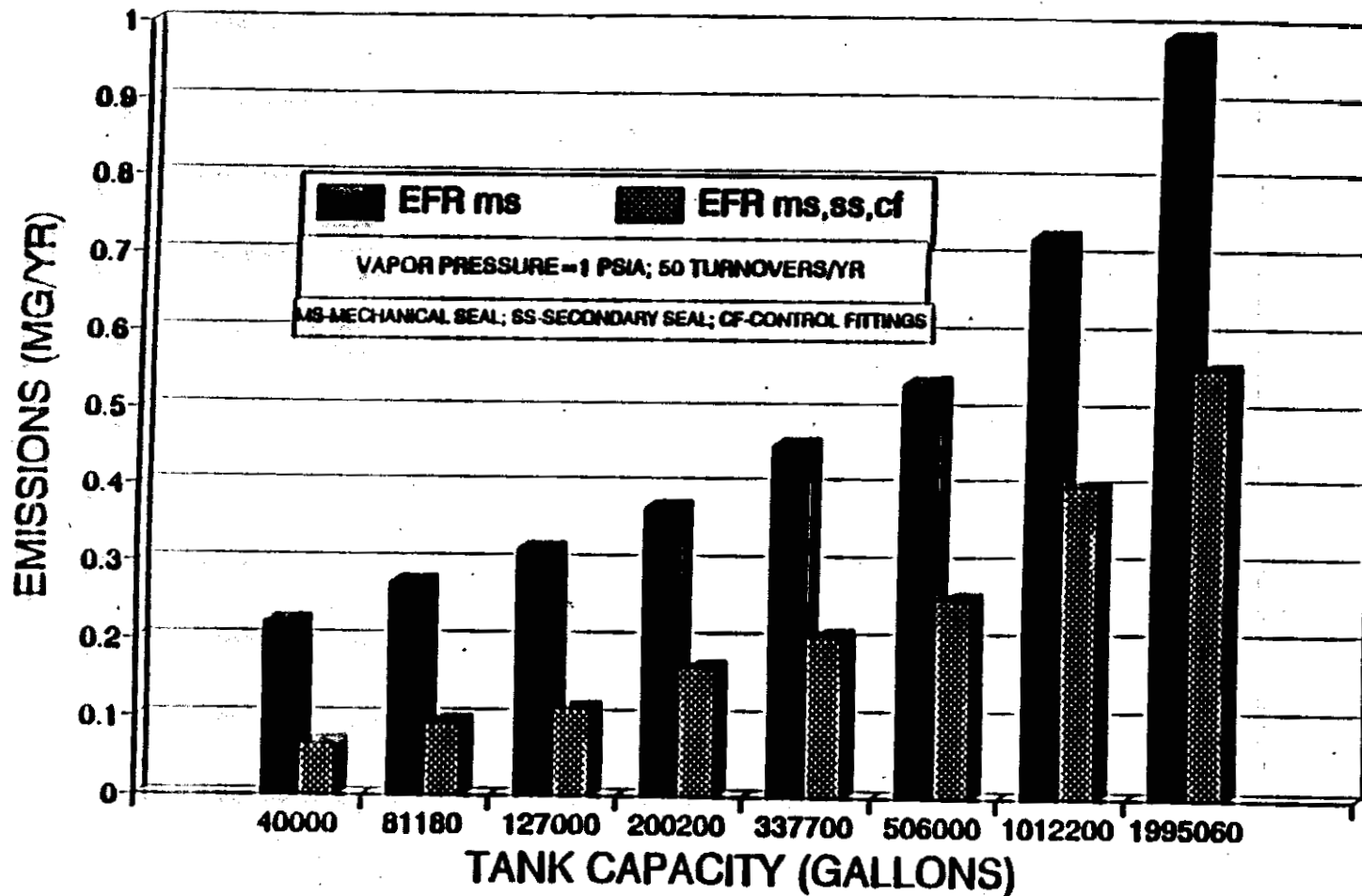

Figure 5-8. The effect of the control options on emissions from external floating roof tanks equipped with mechanical shoe seals as a function of tank volume.

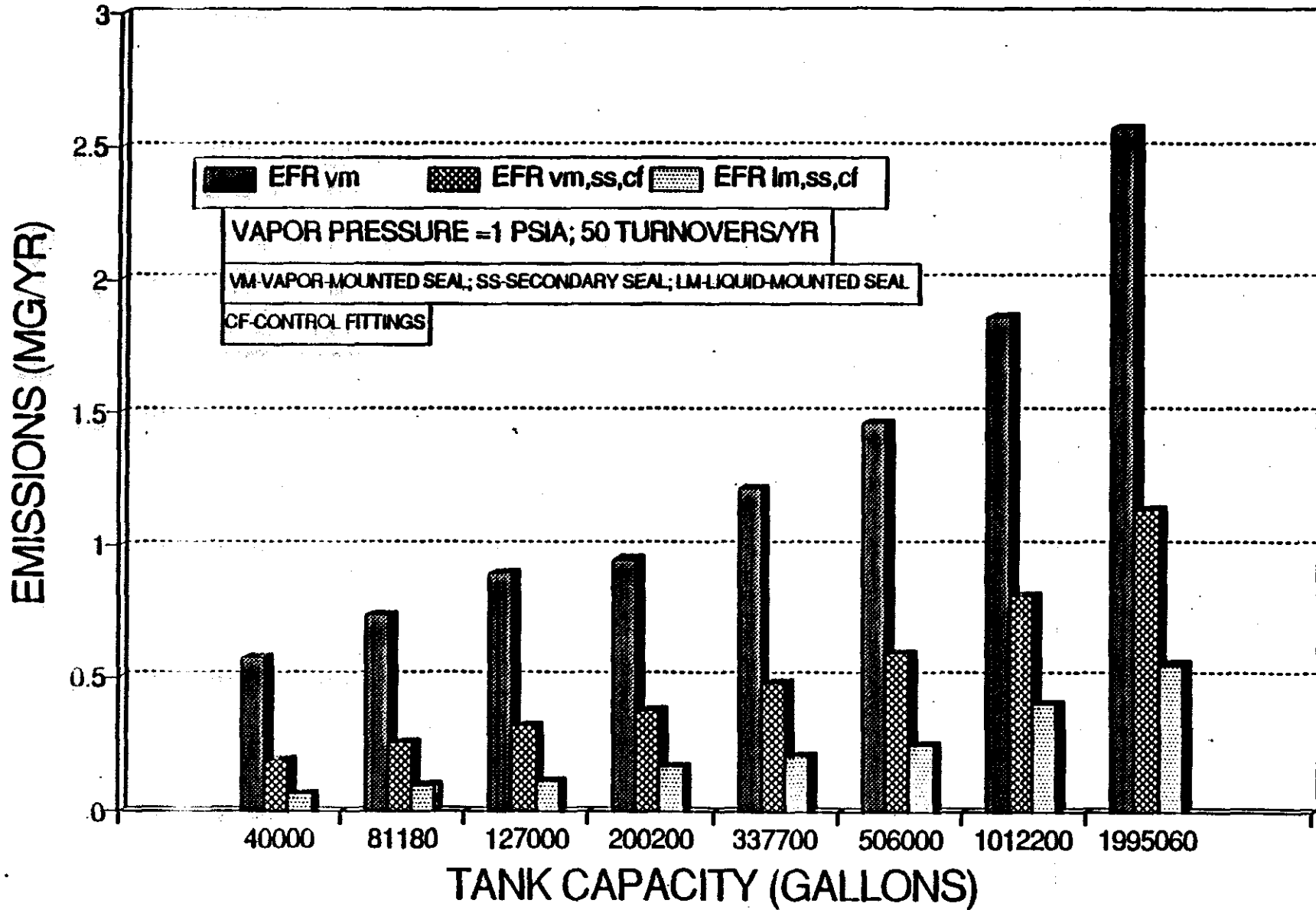

Figure 5-9. The effect of the control options on emissions from external floating roof tanks equipped with vapor-mounted primary seals as a function of tank volume.

TABLE 5-1: NATIONWIDE ENVIRONMENTAL IMPACTS OF THE FIXED-ROOF TANK CONTROL OPTIONS

Control options/cutoff values	Nationwide emissions estimates, Mg/yr (tons/yr)	Nationwide emissions reductions, Mg/yr (tons/yr)	Nationwide secondary emissions, Mg/yr (tons/yr)	Nationwide hazardous waste disposal, <i>l</i> (gal)
Baseline				
VP = 0.5 ^a	54,690 (60,770)	--	--	--
VP = 0.75 ^b	50,470 (56,080)	--	--	--
VP = 1.0 ^c	44,170 (49,080)	--	--	--
Control Option I^d				
VP = 0.5 ^a	2,730 (3,040)	51,960 (57,730)	2,630-31,630 (2,890-34,790)	595 x 10 ⁶ (157 x 10 ⁶)
VP = 0.75 ^b	2,520 (2,800)	47,950 (53,280)	2,110-25,360 (2,330-27,870)	477 x 10 ⁶ (126 x 10 ⁶)
VP = 1.0 ^c	2,200 (2,450)	41,970 (46,630)	1,540-18,440 (1,710-20,260)	347 x 10 ⁶ (92 x 10 ⁶)
Control Option II^e				
VP = 0.5 ^a	2,040 (2,270)	52,650 (58,500)	2,630-31,630 (2,890-34,790)	595 x 10 ⁶ (157 x 10 ⁶)
VP = 0.75 ^b	1,840 (2,050)	48,630 (54,030)	2,110-25,360 (2,330-27,870)	477 x 10 ⁶ (126 x 10 ⁶)
VP = 1.0 ^c	1,720 (1,910)	42,450 (47,170)	1,540-18,440 (1,710-20,260)	347 x 10 ⁶ (92 x 10 ⁶)
Control Option III^f				
VP = 0.5 ^a	1,910 (2,130)	52,780 (58,640)	2,630-31,630 (2,890-34,790)	595 x 10 ⁶ (157 x 10 ⁶)
VP = 0.75 ^b	1,800 (2,000)	48,670 (54,080)	2,110-25,360 (2,330-27,870)	477 x 10 ⁶ (126 x 10 ⁶)
VP = 1.0 ^c	1,630 (1,810)	42,540 (47,270)	1,540-18,440 (1,710-20,260)	347 x 10 ⁶ (92 x 10 ⁶)
Control Option IV^g				
VP = 0.5 ^a	1,000 (1,120)	53,690 (59,650)	2,630-31,630 (2,890-34,790)	595 x 10 ⁶ (157 x 10 ⁶)
VP = 0.75 ^b	1,010 (1,120)	49,460 (54,960)	2,110-25,360 (2,330-27,870)	477 x 10 ⁶ (126 x 10 ⁶)
VP = 1.0 ^c	1,000 (1,110)	43,170 (47,970)	1,540-18,440 (1,710-20,260)	347 x 10 ⁶ (92 x 10 ⁶)

^aBased on a vapor pressure cutoff value of 0.5 psia and a tank capacity cutoff value of 40,000 gallons.

^bBased on a vapor pressure cutoff value of 0.75 psia and a tank capacity cutoff value of 40,000 gallons.

^cBased on a vapor pressure cutoff value of 1.0 psia and a tank capacity cutoff value of 40,000 gallons.

^dControl Option I = installation of an aluminum noncontact IFR with vapor-mounted primary seals and uncontrolled fittings.

^eControl Option II = installation of an aluminum noncontact IFR with vapor-mounted primary seals, secondary seals, and controlled fittings.

^fControl Option III = installation of an aluminum noncontact IFR with liquid-mounted primary seals, secondary seals, and controlled fittings.

^gControl Option IV = installation of a welded steel contact IFR with liquid-mounted primary seals, secondary seals, and controlled fittings.

TABLE 5-2. NATIONWIDE ENVIRONMENTAL IMPACTS OF THE INTERNAL FLOATING ROOF TANK CONTROL OPTIONS

Control options/cutoff values	Nationwide emission estimates Mg/yr (tons/yr)	Nationwide emissions reduction, Mg/yr (tons/yr)
<u>Baseline</u>		
VP = 0.5 ^a	16,430 (18,070)	--
VP = 0.75 ^b	16,260 (17,890)	--
VP = 1.0 ^c	16,010 (17,610)	--
VP = 1.5 ^d	15,620 (17,180)	--
<u>Control Option I^e</u>		
VP = 0.5 ^a	15,570 (17,120)	860 (950)
VP = 0.75 ^b	15,410 (16,950)	850 (940)
VP = 1.0 ^c	15,160 (16,670)	850 (940)
VP = 1.5 ^d	14,780 (16,260)	840 (920)
<u>Control Option II^f</u>		
VP = 0.5 ^a	11,680 (12,840)	4,750 (5,230)
VP = 0.75 ^b	11,540 (12,700)	4,720 (5,190)
VP = 1.0 ^c	11,320 (12,450)	4,690 (5,160)
VP = 1.5 ^d	10,990 (12,090)	4,630 (5,090)
<u>Control Option III^g</u>		
VP = 0.5 ^a	10,140 (11,150)	6,290 (6,920)
VP = 0.75 ^b	10,000 (11,000)	6,260 (6,890)
VP = 1.0 ^c	9,800 (10,780)	6,210 (6,830)
VP = 1.5 ^d	9,490 (10,440)	6,130 (6,740)
<u>Control Option IV^h</u>		
VP = 0.5 ^a	4,560 (5,010)	11,870 (13,060)
VP = 0.75 ^b	4,450 (4,900)	11,810 (12,990)
VP = 1.0 ^c	4,290 (4,720)	11,720 (12,890)
VP = 1.5 ^d	4,050 (4,450)	11,570 (12,730)

^aBased on a vapor pressure cutoff value of 0.5 psia and a tank capacity cutoff value of 40,000 gallons and greater.

^bBased on a vapor pressure cutoff value of 0.75 psia and a tank capacity cutoff value of 40,000 gallons and greater.

^cBased on a vapor pressure cutoff value of 1.0 psia and a tank capacity cutoff value of 40,000 gallons and greater.

^dBased on a vapor pressure cutoff value of 1.5 psia and a tank capacity cutoff value of 40,000 gallons and greater.

^eControl Option I = control fittings.

^fControl Option II = control fittings and add a secondary seal.

^gControl Option III = replace vapor-mounted primary seal with liquid-mounted primary seal, secondary seals, and controlled fittings.

^hControl Option IV = replace noncontact IFR with a welded steel contact IFR with liquid-mounted primary seals, secondary seals, and controlled fittings.

TABLE 5-3. NATIONWIDE SECONDARY ENVIRONMENTAL IMPACTS OF THE INTERNAL FLOATING ROOF TANK CONTROL OPTIONS

Control options/cutoff values	Nationwide secondary emissions, Mg/yr (tons/yr)	Nationwide hazardous waste disposal ℓ /gal
Baseline		
VP = 0.5 ^a	--	--
VP = 0.75 ^b	--	--
VP = 1.0 ^c	--	--
VP = 1.5 ^d	--	--
Control Option I^e		
VP = 0.5 ^a	6,780-81,360 (7,458-89,500)	41 x 10 ⁶ (37 x 10 ⁶)
VP = 0.75 ^b	6,590-79,020 (7,240-86,922)	40 x 10 ⁶ (36 x 10 ⁶)
VP = 1.0 ^c	6,390-76,690 (7,030-84,360)	38 x 10 ⁶ (35 x 10 ⁶)
VP = 1.5 ^d	6,150-73,850 (6,770-81,240)	37 x 10 ⁶ (34 x 10 ⁶)
Control Option II^f		
VP = 0.5 ^a	6,780-81,360 (7,458-89,500)	41 x 10 ⁶ (37 x 10 ⁶)
VP = 0.75 ^b	6,590-79,020 (7,240-86,922)	40 x 10 ⁶ (36 x 10 ⁶)
VP = 1.0 ^c	6,390-76,690 (7,030-84,360)	38 x 10 ⁶ (35 x 10 ⁶)
VP = 1.5 ^d	6,150-73,850 (6,770-81,240)	37 x 10 ⁶ (34 x 10 ⁶)
Control Option III^g		
VP = 0.5 ^a	6,780-81,360 (7,458-89,500)	41 x 10 ⁶ (37 x 10 ⁶)
VP = 0.75 ^b	6,590-79,020 (7,240-86,922)	40 x 10 ⁶ (36 x 10 ⁶)
VP = 1.0 ^c	6,390-76,690 (7,030-84,360)	38 x 10 ⁶ (35 x 10 ⁶)
VP = 1.5 ^d	6,150-73,850 (6,770-81,240)	37 x 10 ⁶ (34 x 10 ⁶)
Control Option IV^h		
VP = 0.5 ^a	6,780-81,360 (7,458-89,500)	41 x 10 ⁶ (37 x 10 ⁶)
VP = 0.75 ^b	6,590-79,020 (7,240-86,922)	40 x 10 ⁶ (36 x 10 ⁶)
VP = 1.0 ^c	6,390-76,690 (7,030-84,360)	38 x 10 ⁶ (35 x 10 ⁶)
VP = 1.5 ^d	6,150-73,850 (6,770-81,240)	37 x 10 ⁶ (34 x 10 ⁶)

^aBased on a vapor pressure cutoff value of 0.5 psia and a tank capacity cutoff value of 40,000 gallons and greater.

^bBased on a vapor pressure cutoff value of 0.75 psia and a tank capacity cutoff value of 40,000 gallons and greater.

^cBased on a vapor pressure cutoff value of 1.0 psia and a tank capacity cutoff value of 40,000 gallons and greater.

^dBased on a vapor pressure cutoff value of 1.5 psia and a tank capacity cutoff value of 40,000 gallons and greater.

^eControl Option I = control fittings.

^fControl Option II = control fittings and add a secondary seal.

^gControl Option III = replace vapor-mounted primary seal with liquid-mounted primary seal, secondary seals, and controlled fittings.

^hControl Option IV = replace noncontact IFR with a welded steel contact IFR with liquid-mounted primary seals, secondary seals, and controlled fittings.

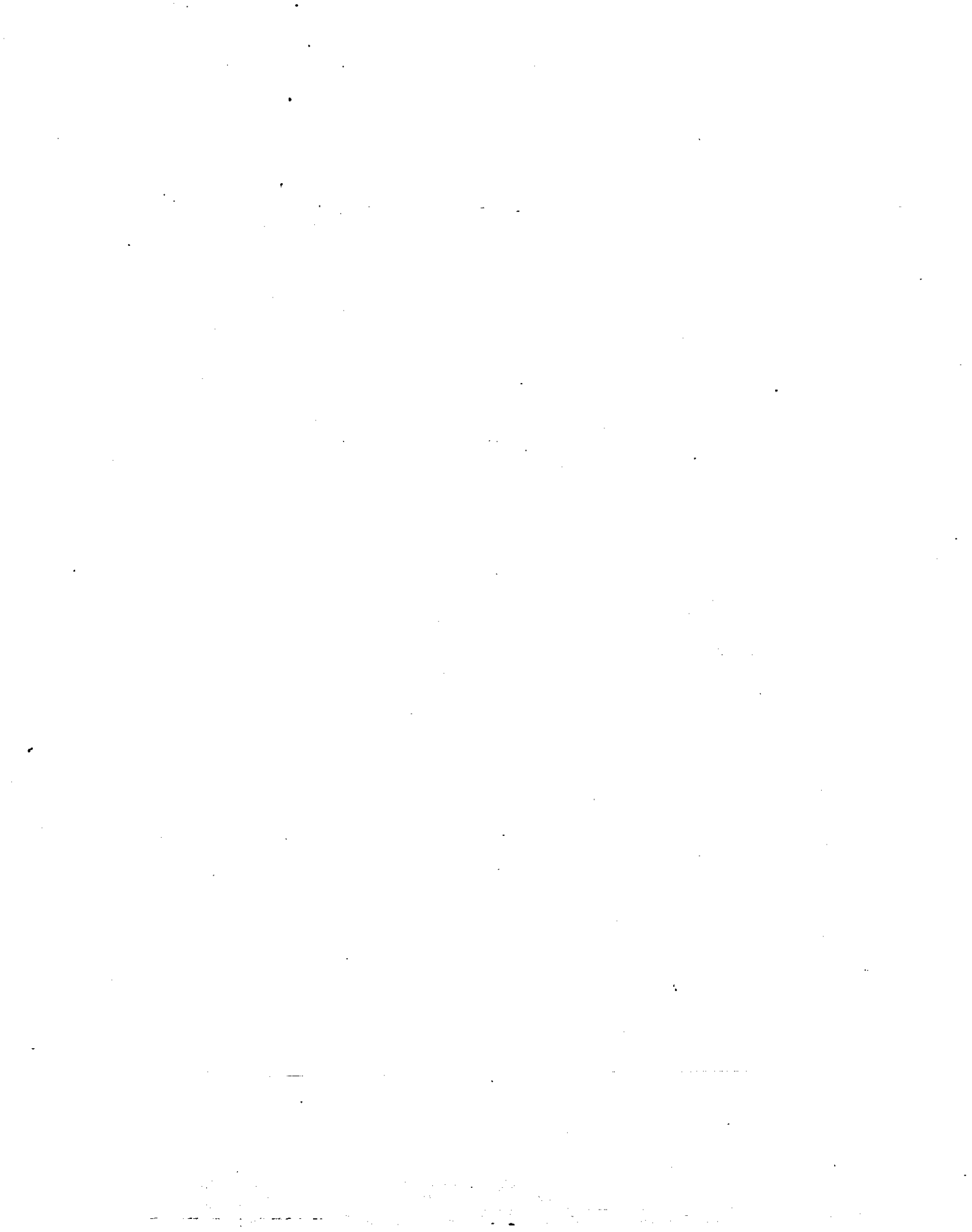

5.6 REFERENCES

1. U. S. Environmental Protection Agency. VOC Emissions from Volatile Organic Liquid Storage Tanks--Background Information for Proposed Standards. EPA-450/3-81/003a. Research Triangle Park, NC. June 1984.
2. Telecon. deOlloqui, V., MRI, to McManus, E., Four Seasons Industrial Services, Greensboro, North Carolina. June 1991. Information on cleaning and degassing of storage tanks.
3. Telecon. deOlloqui, V., MRI, to Moffit, L., Pittsburgh/Des Moines, Inc., Pittsburgh, Pennsylvania. June 26, 1991. Information on the requirements for cleaning and degassing prior to the installation of control equipment on external floating roof tanks.
4. U. S. Environmental Protection Agency. 1991 Ozone Nonattainment Status Data Base. National Air Data Branch, OAQPS.



6.0 COST ANALYSIS OF CONTROL OPTIONS

6.1 INTRODUCTION

This chapter presents the costs of equipping fixed-roof (FR), internal floating roof (IFR), and external floating roof (EFR) tanks with the control equipment described in Chapter 4. Three types of cost data are presented:

1. Capital cost;
2. Annual cost; and
3. Cost effectiveness.

The cost analysis follows a prescribed approach. Capital costs, which represent the initial investment for control equipment and installation, are estimated based on vendor quotes and EPA protocols. From these estimates, correlations and factors have been developed to approximate capital costs for the range of tank sizes commonly used in the industry. The capital cost is annualized by applying a capital recovery factor, which is based on an estimated equipment lifetime, and the interest rate on the capital, and by adding costs for taxes and insurance. The total annualized cost, excluding product recovery credits, attributable to each type of control is estimated by adding operating costs to the annualized capital cost. The total or net annualized cost, including product recovery credits, is estimated by subtracting the value of the recovered product from the annualized cost. The amount of recovered product is equal to the difference in emissions between the baseline and the control option levels. Cost effectiveness is the total annualized cost divided by the emission reduction obtained by each control technology .

6.2 EQUIPMENT COSTS

Capital equipment costs that depend on tank size were obtained from vendors for various tank capacities and tank diameters.¹⁻³ A regression analysis was then performed on the data to obtain an equation that could be used to develop capital equipment costs for any tank capacity. The costs provided by vendors and the equations used to develop model tank costs for installing an IFR in a FR tank and for retrofitting a noncontact IFR tank with a contact IFR are presented in Table 6-1. The cost difference of constructing a liquid-mounted primary seal rather than a vapor-mounted primary seal is \$65 per linear meter (\$20 per linear foot).¹ The additional cost of controlling fittings is estimated at \$200 for newly installed floating roofs and \$600 for existing floating roofs.¹ The installation of secondary seals on existing internal floating roofs is estimated at \$83 per linear meter (\$26/ft).^{1,2} On new installations there is no additional charge for the secondary seals.

The retrofit cost to add secondary seals to an external floating roof is estimated at \$180 per linear meter (\$54/ft).² The additional cost of controlling fittings is estimated at \$680, which is mainly for controlling the guidepole fitting since other EFR fittings are typically controlled already. The retrofit cost for replacing a vapor-mounted primary seal with a liquid-mounted primary seal on EFR tanks is estimated at \$260 per linear meter (\$80/ft).²

Cleaning and degassing costs can be subdivided into two separate costs: (1) cleaning and (2) hazardous waste disposal costs. An estimated cleaning and degassing cost of \$18,000 to \$20,000 was obtained from a tank service company for a 757,090-liter (1) (200,000-gallon [gal]) tank.⁴ For the purposes of this analysis, it was assumed that the sludge and rinseate generated from cleaning the tank will have to be treated, stored, and disposed as a hazardous waste. The hazardous waste generated from cleaning this size tank was estimated at 11,370 l (3,000 gal), which consists of 3,790 l (1,000 gal) of rinseate and 7,570 l (2,000 gal) of sludge. A tank service company

estimated the hazardous waste disposal costs at \$1.30/1 (\$5/gal).⁴ Because cost estimates were only provided by one tank service company for one tank size, cleaning and degassing costs were not estimated for each model tank. Instead estimates for these services were developed for representative tanks which were then used to determine the nationwide cost impacts presented in Section 6-4. In examining the effect of the cleaning and hazardous waste disposal costs, it was determined that these costs comprise the majority of the capital cost associated with installing control equipment when cleaning and degassing is necessary. Therefore, the capital and annualized costs for the control options that include cleaning and degassing prior to the installation of controls are largely dependent on the cleaning and disposal costs.

Annual costs for equipment were developed assuming an equipment life of 10 years and an interest rate of 10 percent. Capital recovery costs, which are the cost of capital spread over the depreciable life of the control equipment, were calculated using the following equation:⁵

$$CRC = [TCC] \left[\frac{i(1+i)^n}{(1+i)^n - 1} \right]$$

where,

CRC = capital recovery cost, \$/yr

TCC = total capital cost, \$

i = annual interest rate, 10 percent

n = depreciable life, 10 years.

The annualized cost without product recovery credits is calculated by adding the annualized capital cost to the costs for taxes, insurance and administration (4 percent of the capital costs) and the operating costs. Operating costs include the yearly maintenance charge of 5 percent of the capital cost, and an inspection charge of 1 percent of the capital cost. However, when annualizing the cost of cleaning and degassing the storage tank and hazardous waste disposal, additional allowances for taxes, insurance, and administration costs were not applied because this work would be provided by a tank service company and is already considered in the cost of the service.

The total annualized cost with product recovery credits is calculated by accounting for the value of any recovered product. The recovered product costs were based on average product values for petroleum liquids and organic chemicals.^{6,7} A price of \$350 per megagram (\$/Mg) (\$320 dollars per ton [\$/ton]) was estimated for tanks storing petroleum products and \$1,510/Mg (\$1,370/ton) was estimated for tanks storing organic chemical products.^{6,7} The amount of recovered product was assumed equal to the emissions difference between the baseline uncontrolled emissions and the control option emissions.

6.3 MODEL TANK COSTS

Model tank costs were calculated for each of the control options under consideration for fixed-roof, internal floating roof, and external floating roof tanks. The model tanks are presented in Chapter 3, and the control options for each tank type are presented in Chapters 4 and 5. Figures 6-1 through 6-12 display the effect of tank volume on the cost effectiveness of fixed roof tanks for three vapor pressures, two turnover rates, and two liquid types. Cost effectiveness is reported on the figures in units of dollars per megagrams (\$/Mg), which is equivalent to dollars per megagram per year annualized over a ten year period.

In the analysis for internal floating roof tanks, the base case is assumed to be an internal floating roof with a vapor-mounted primary seal and typical fittings. Figures 6-13 through 6-18 display the effect of tank volume on the cost effectiveness of internal floating roof tanks for three vapor pressures and two liquid types.

In the analysis for external floating roof tanks, two base cases were assumed: (1) an external floating roof with mechanical shoe primary seals; and (2) an external floating roof with vapor-mounted primary seals. Figures 6-19 and 6-20 display the effect of tank volume on the cost effectiveness of external floating roof tanks with mechanical shoe primary seals for three vapor pressures and two liquid types. Figures 6-21 and 6-22 display the effect of the tank volume on the cost effectiveness of

external floating roof tanks with vapor-mounted primary seals for three vapor pressures and two liquid types.

6.4 NATIONWIDE COST IMPACTS

Nationwide cost impacts were calculated in a similar manner as that described in Chapter 5 for secondary environmental impacts. Briefly, capital and annualized costs for a representative tank of each tank type were determined and then multiplied by the estimated number of affected tanks for the given control option to obtain nationwide cost impacts. The nationwide cost-effectiveness values were then determined by dividing the nationwide annual cost by the nationwide emissions reduction obtained by the control options. The nationwide cost impacts for fixed-roof, internal floating roof, and external floating roof tanks are shown in Table 6-2 through 6-4, respectively.

All of the control options for fixed-roof tanks include degassing costs. For the representative fixed-roof tank with a tank capacity of 4.9 million liters (1.3 million gallons), it was estimated that cleaning costs were approximately \$30,000 and hazardous waste disposal costs were estimated at an additional \$30,000 based on the disposal of 22,710 L (6,000 gal) of hazardous waste. Therefore, a total of \$60,000 was attributed to cleaning and degassing cost. Also, to account for problem liquids it was assumed that for any option, 50 percent of the tanks in the chemical industry would be controlled with welded steel IFR's with a seal cost of \$335 per linear meter (\$105/ft). However, the impacts presented for internal and external floating roof tanks do not include degassing costs. Although the majority of control options for internal floating roof tanks and Control Option II for external floating roof tanks equipped with vapor-mounted primary seals require degassing, the costs associated with this service were not included because it is assumed that the control equipment will be installed on the tank following a regularly scheduled degassing. Most storage tanks are degassed and cleaned every 5 to 10 years.

The nationwide cost-effectiveness values for internal floating roof tanks are lower than the cost-effectiveness values for individual model tanks shown in Figures 6-13 through 6-18 because the majority of IFR tanks (90 to 95 percent) are storing liquids with vapor pressures at or above 10.3 kPa (1.5 psia) and the lower cost-effectiveness values for these tanks offset the higher cost-effectiveness values for the remaining affected tanks at the lower vapor pressures (10.3 kPa [1.5 psia] and below).

Nationwide cost impacts are not presented for the control options for the baseline external floating roof tank with vapor-mounted primary seals because no data were available that could be used to determine the number of tanks in each vapor pressure range according to seal type. Therefore, it was assumed that all EFR tanks are equipped with mechanical shoe primary seals, which is the most typical primary seal used on EFR tanks. It was also assumed that all EFR tanks storing liquids with vapor pressures above 10.3 kPa (1.5 psia) were already equipped with secondary seals, because the States in implementing the EFR CTG did not distinguish between seal types in requiring secondary seals on tanks storing liquids with vapor pressures at or above 10.3 kPa (1.5 psia). Therefore, nationwide cost-effectiveness values for EFR tanks are lower than those presented earlier for individual model tanks, because the majority of EFR tanks store liquids above 10.3 kPa (1.5 psia) and the cost associated with fitting control is relatively low.

6.5 UNCERTAINTIES

The costs that are provided in this chapter represent an estimation of the potential nationwide impacts of implementing the control options. These costs are only estimations representing average control cost. For example, costs may be greater for tanks storing problem liquids due to increased material costs, or alternatively, costs may be less than estimated due to less sludge and therefore less sludge disposal costs.

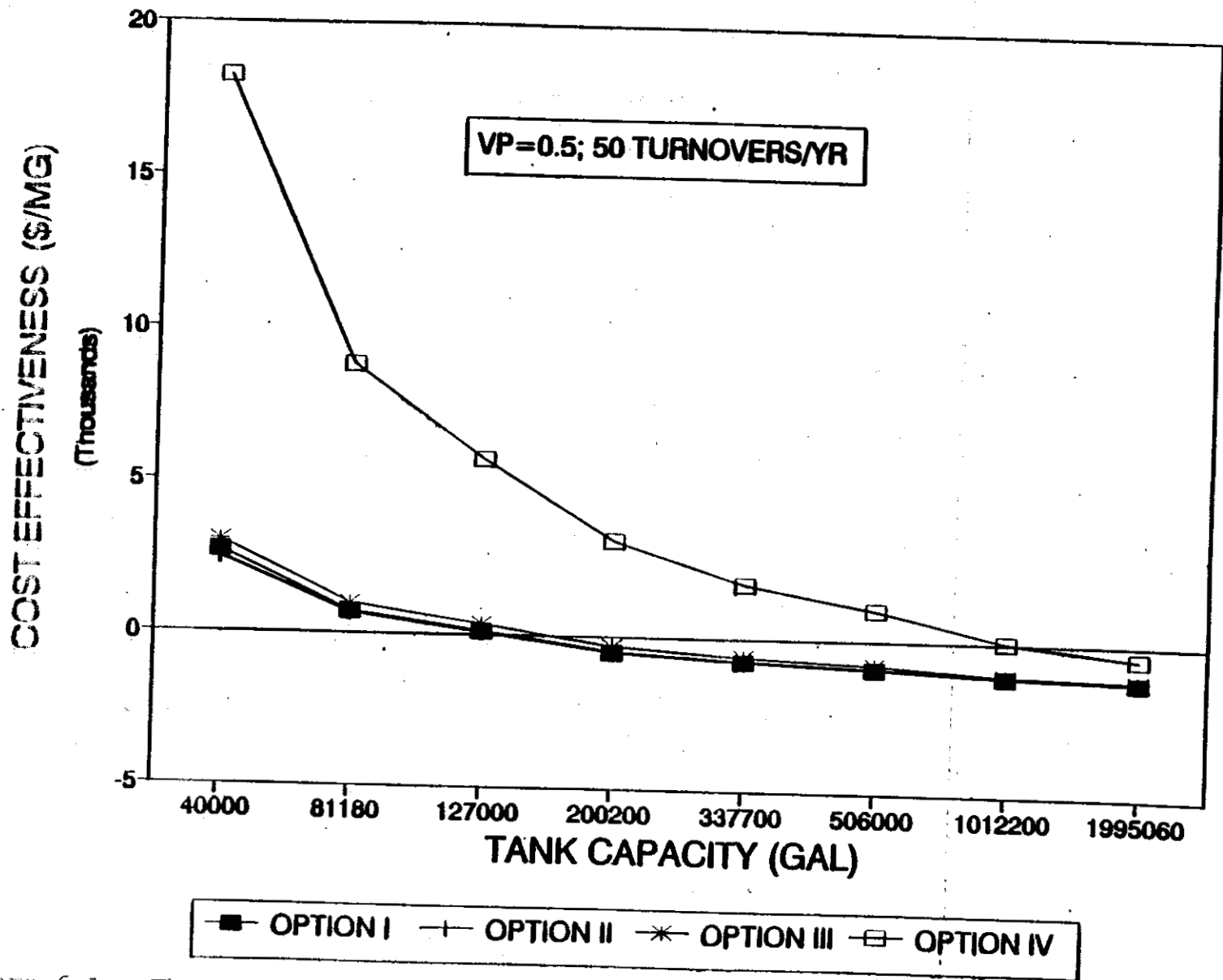

Figure 6-1. The cost-effectiveness of control options on fixed roof tanks storing VOL as a function of tank volume.

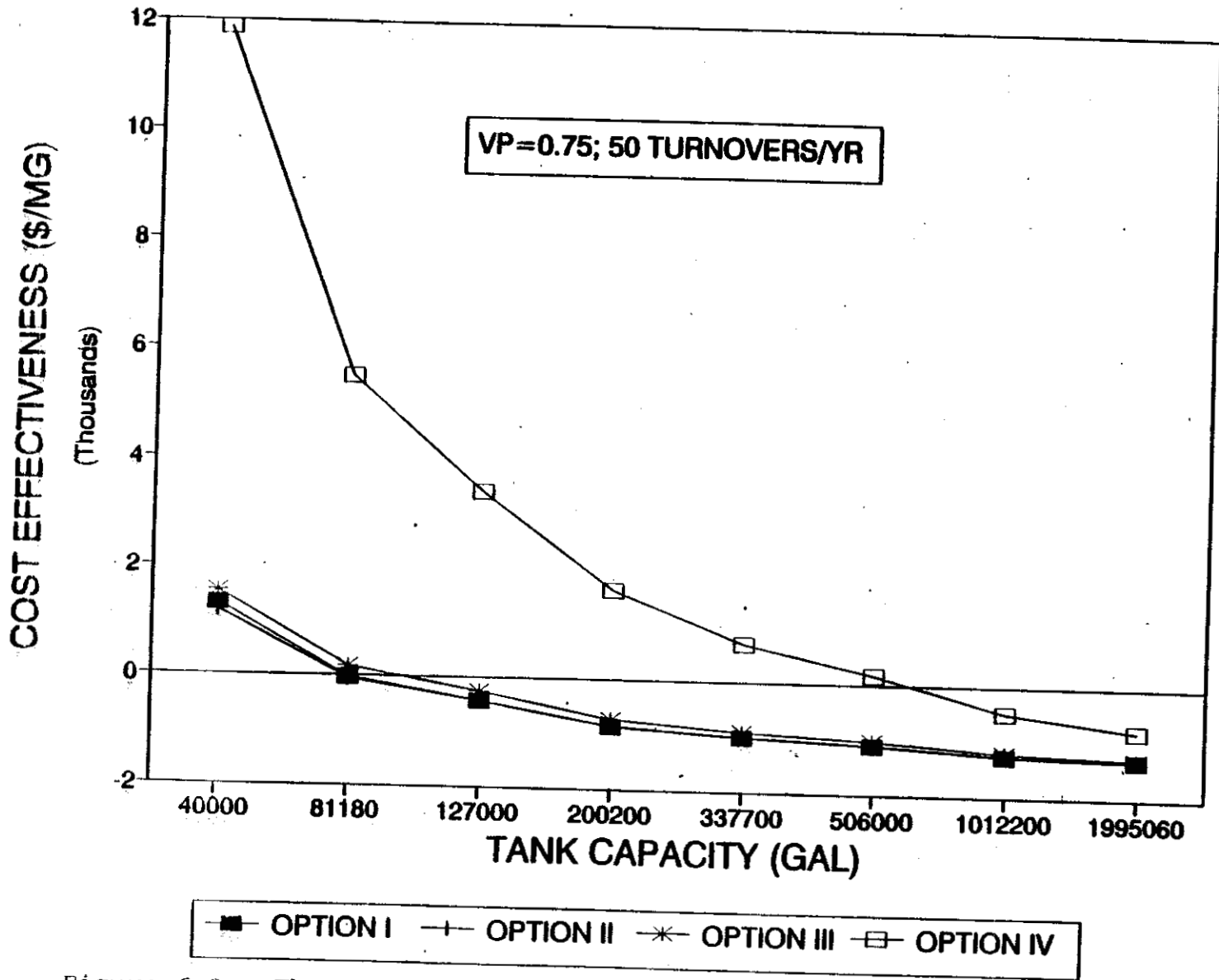

Figure 6-2. The cost-effectiveness of control options on fixed-roof tanks storing VOL as a function of tank volume.

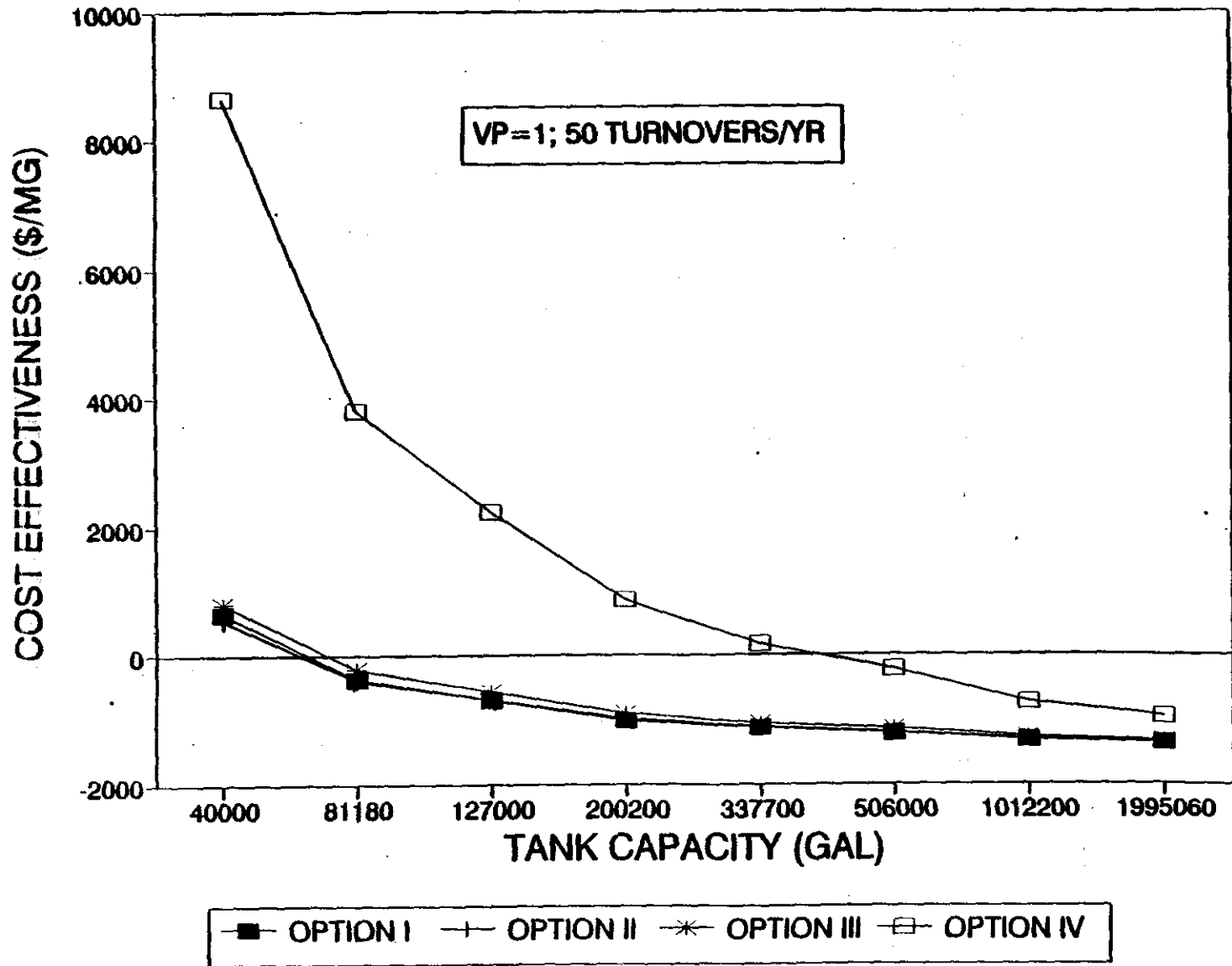

Figure 6-3. The cost-effectiveness of control options on fixed-roof tanks storing VOL as a function of tank volume.

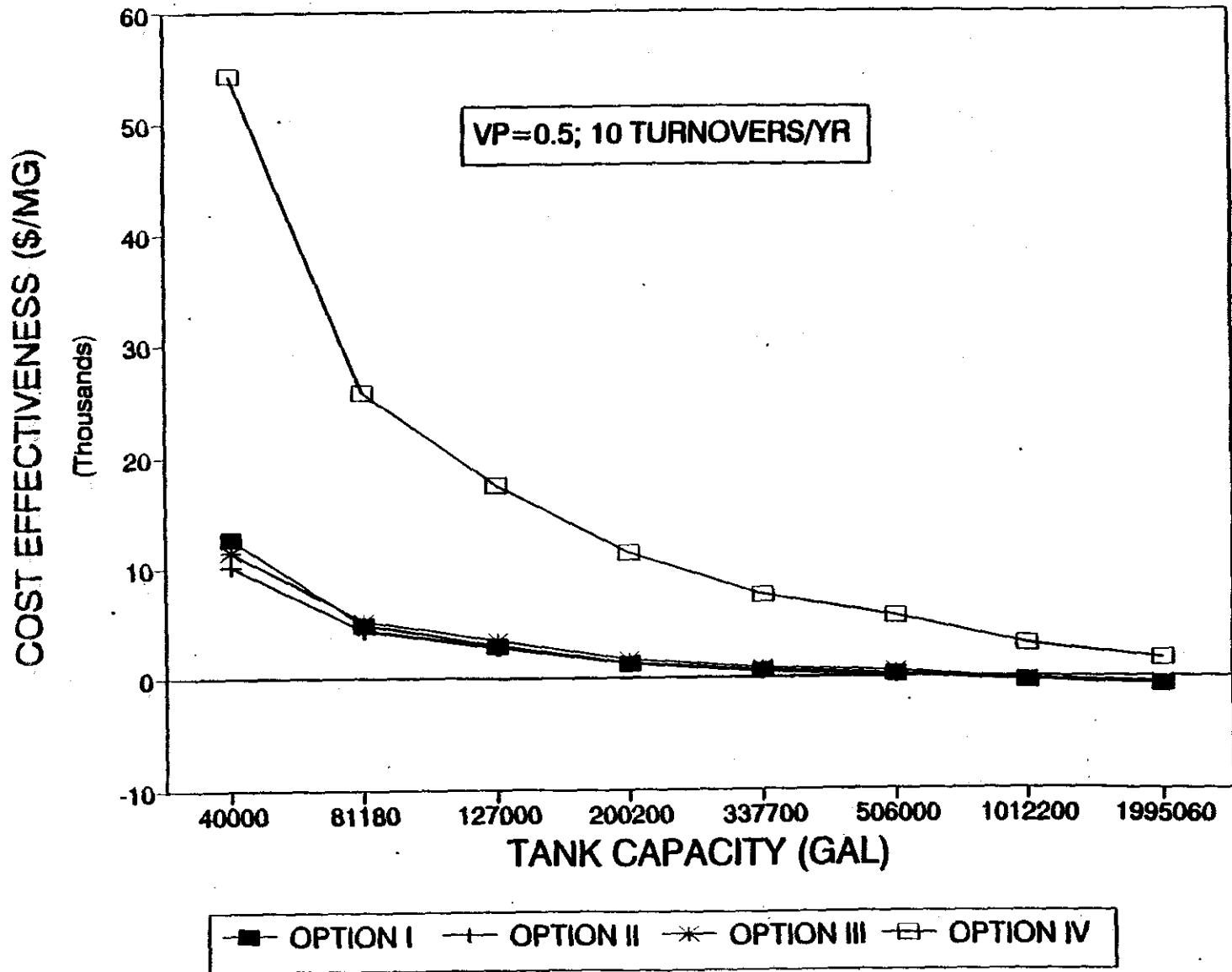

Figure 6-4. The cost-effectiveness of control options on fixed-roof tanks storing VOL as a function of tank volume.

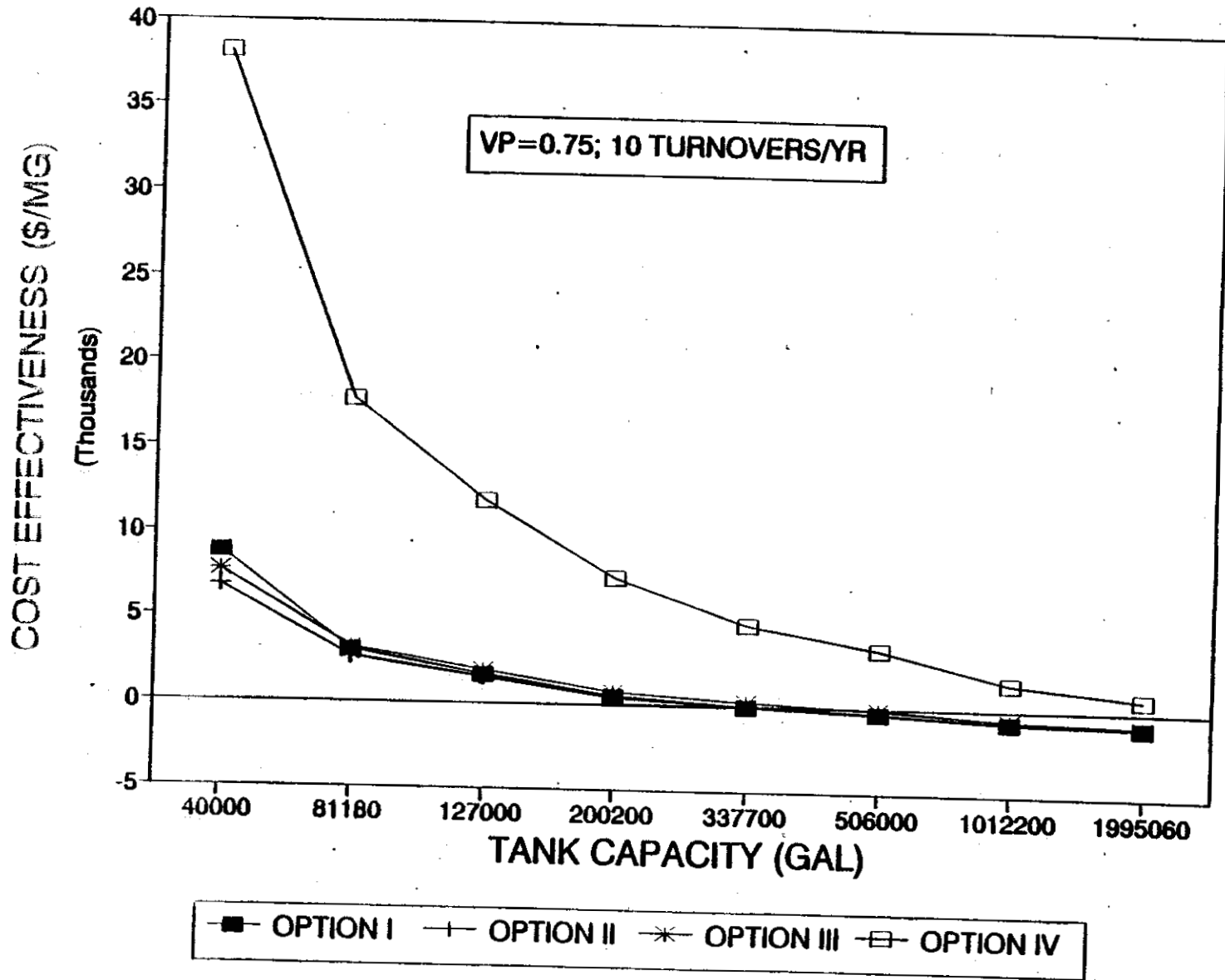

Figure 6-5. The cost-effectiveness of control options on fixed-roof tanks storing VOL as a function of tank volume.

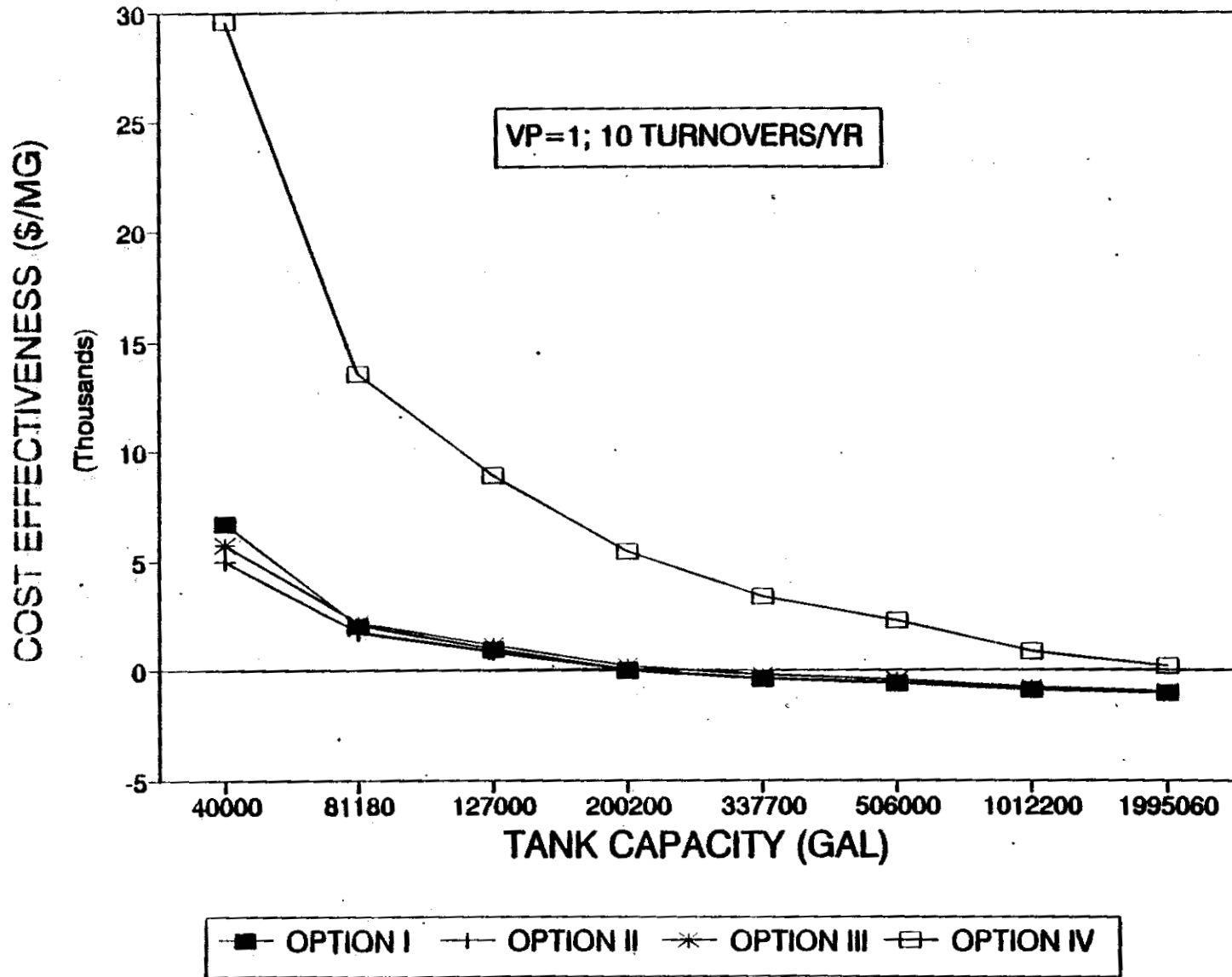

Figure 6-6. The cost-effectiveness of control options on fixed-roof tanks storing VOL as a function of tank volume.

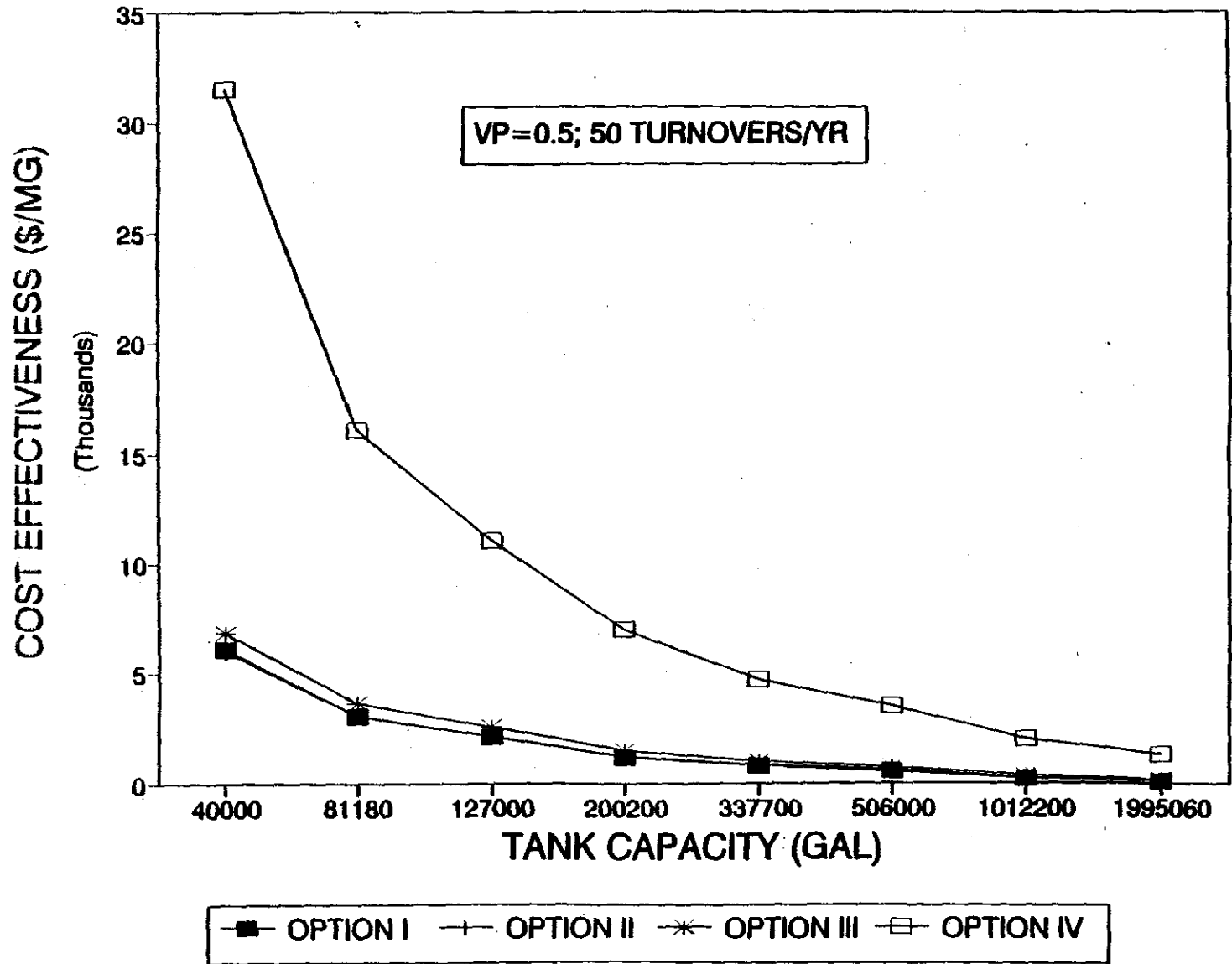

Figure 6-7. The cost-effectiveness of control options on fixed-roof tanks storing crude oil as a function of tank volume.

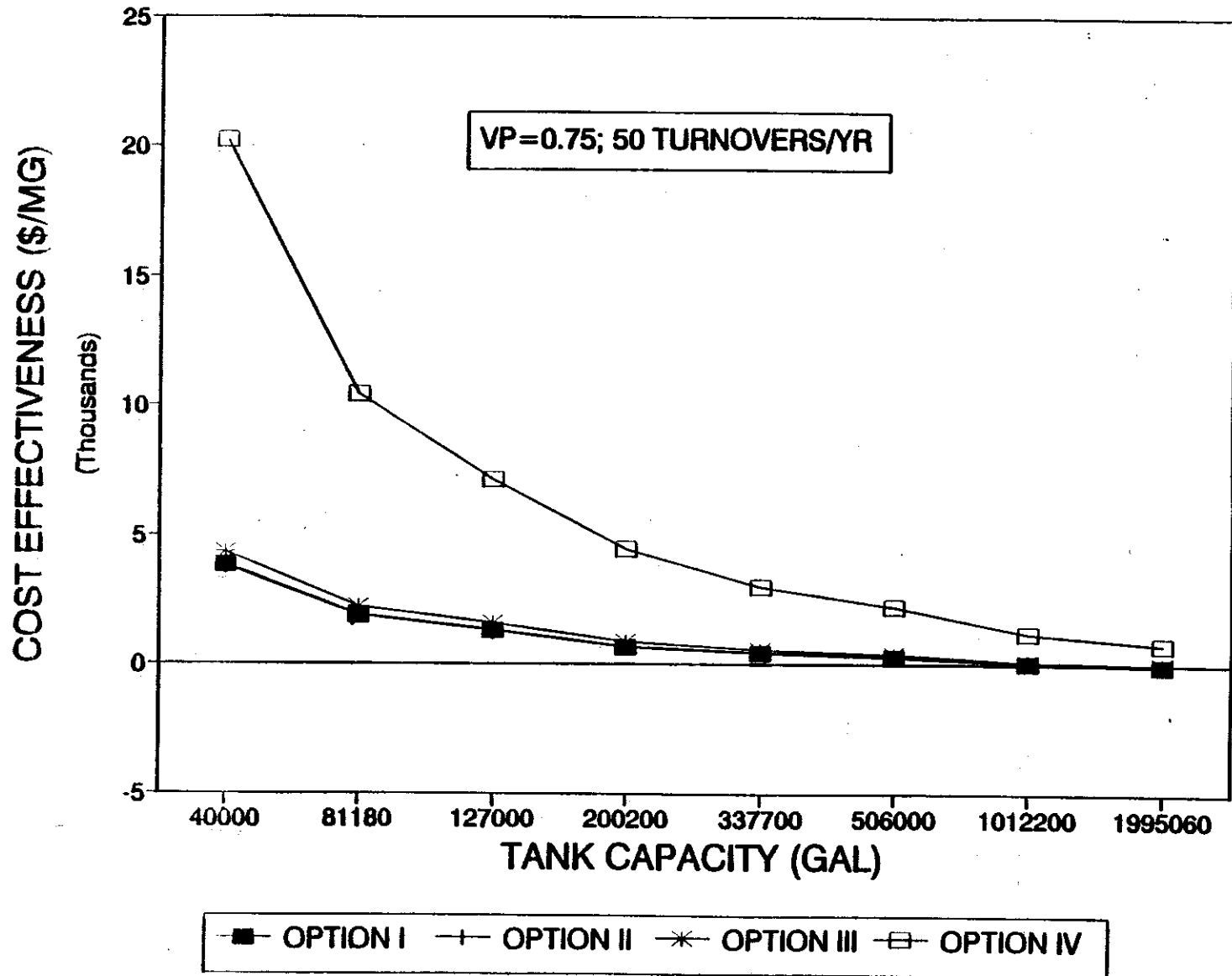

Figure 6-8. The cost-effectiveness of control options on fixed-roof tanks storing crude oil as a function of tank volume.

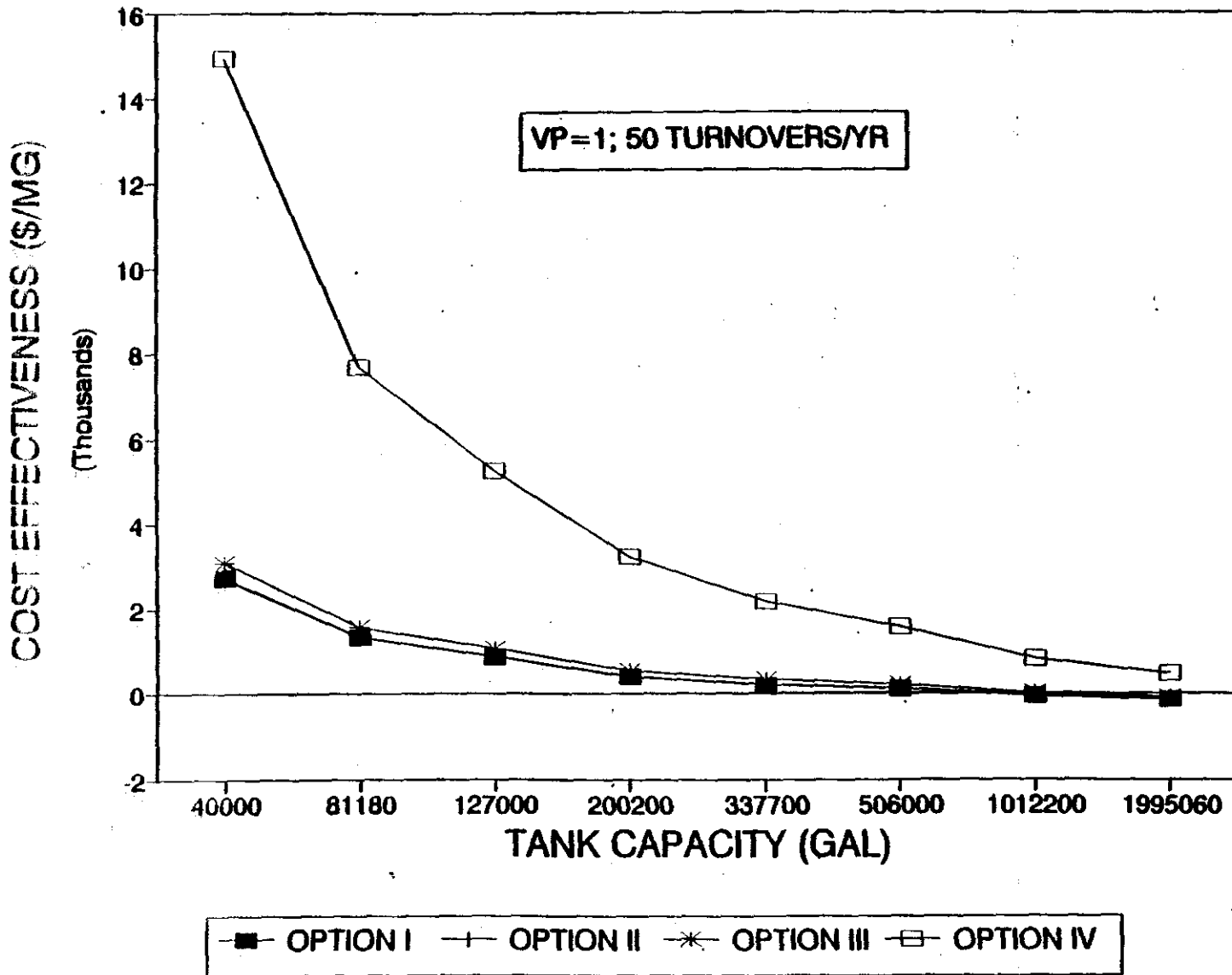

Figure 6-9. The cost-effectiveness of control options on fixed-roof tanks storing crude oil as a function of tank volume.

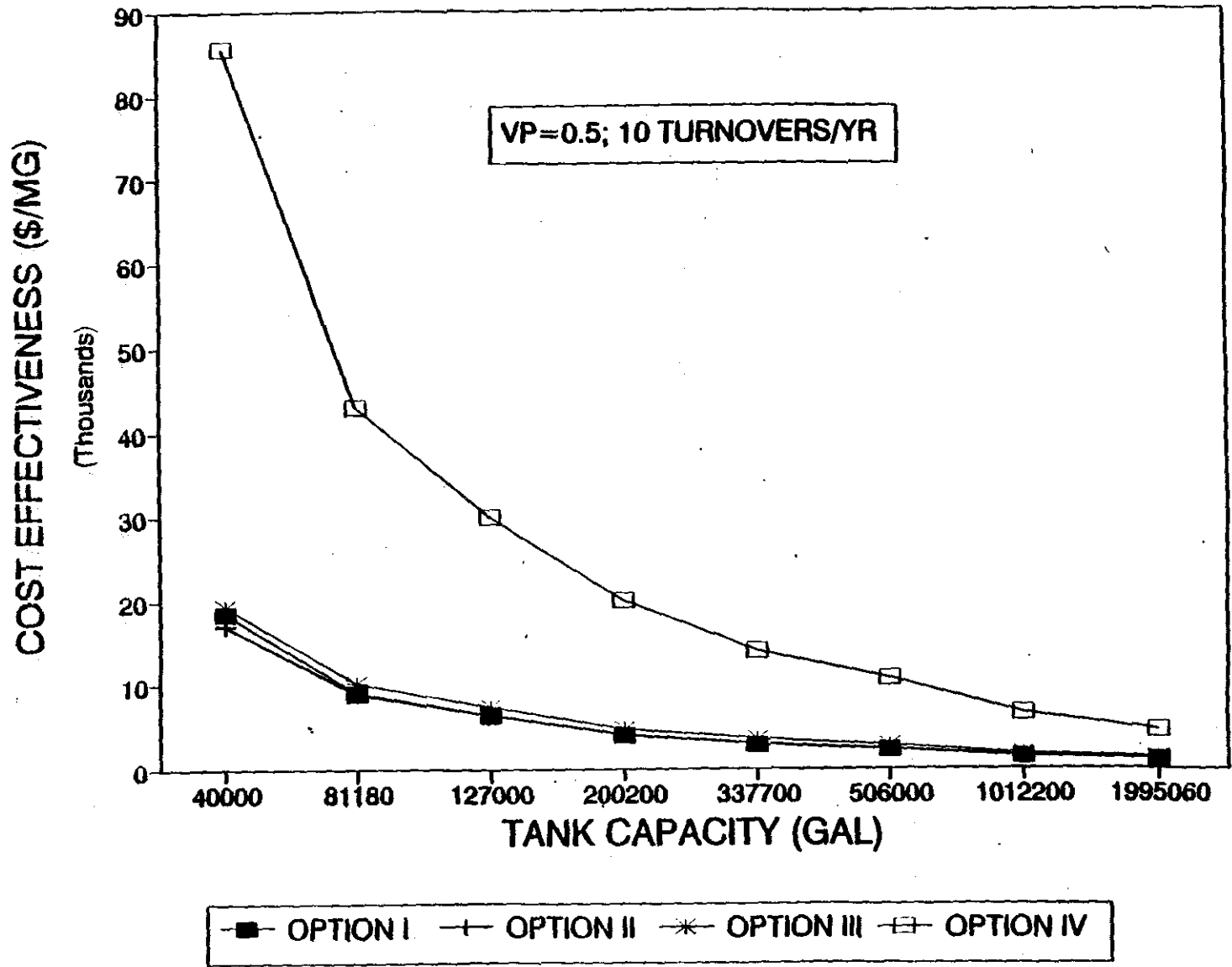

Figure 6-10. The cost-effectiveness of control options on fixed-roof tanks storing crude oil as a function of tank volume.

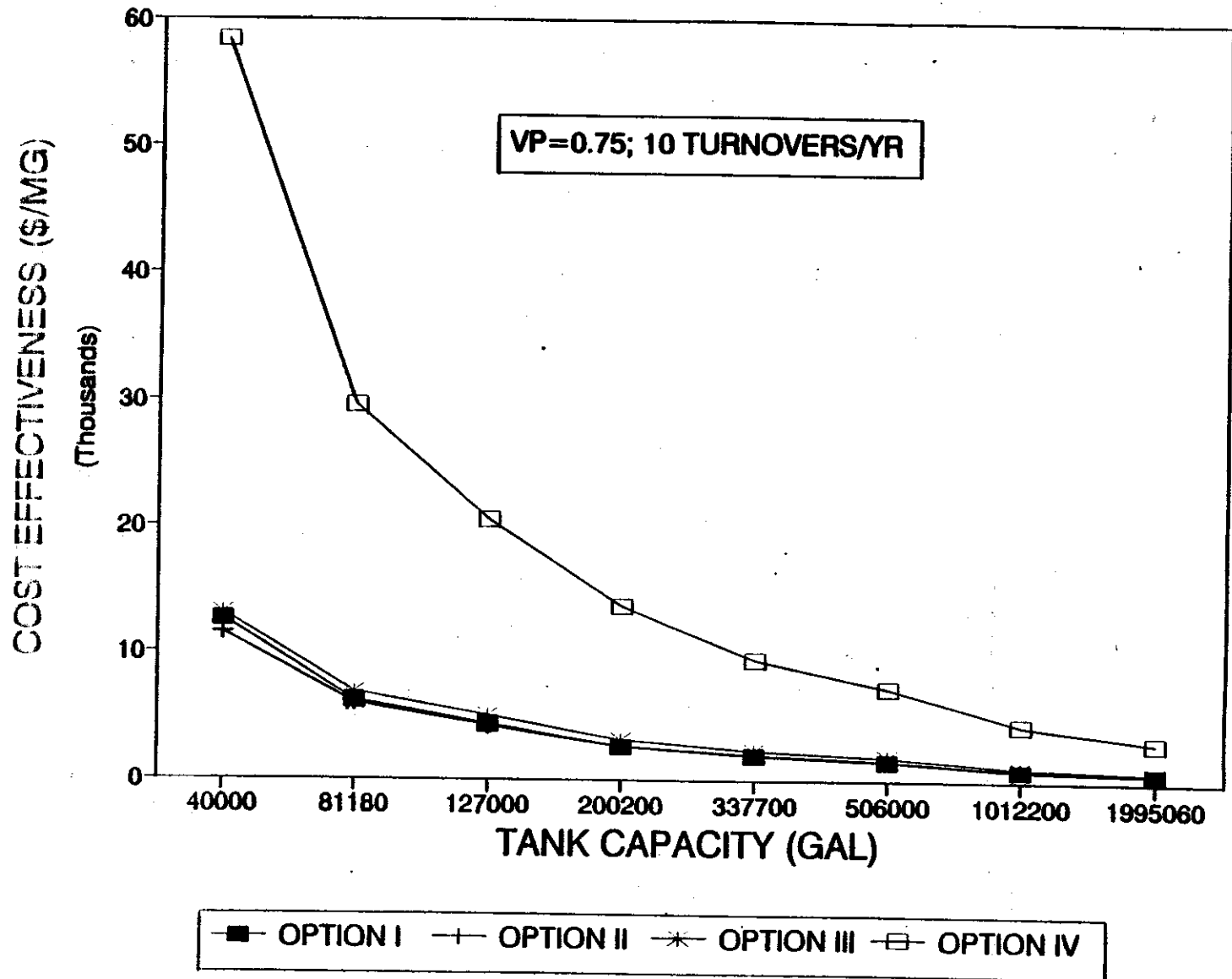

Figure 6-11. The cost-effectiveness of control options on fixed-roof tanks storing crude oil as a function of tank volume.

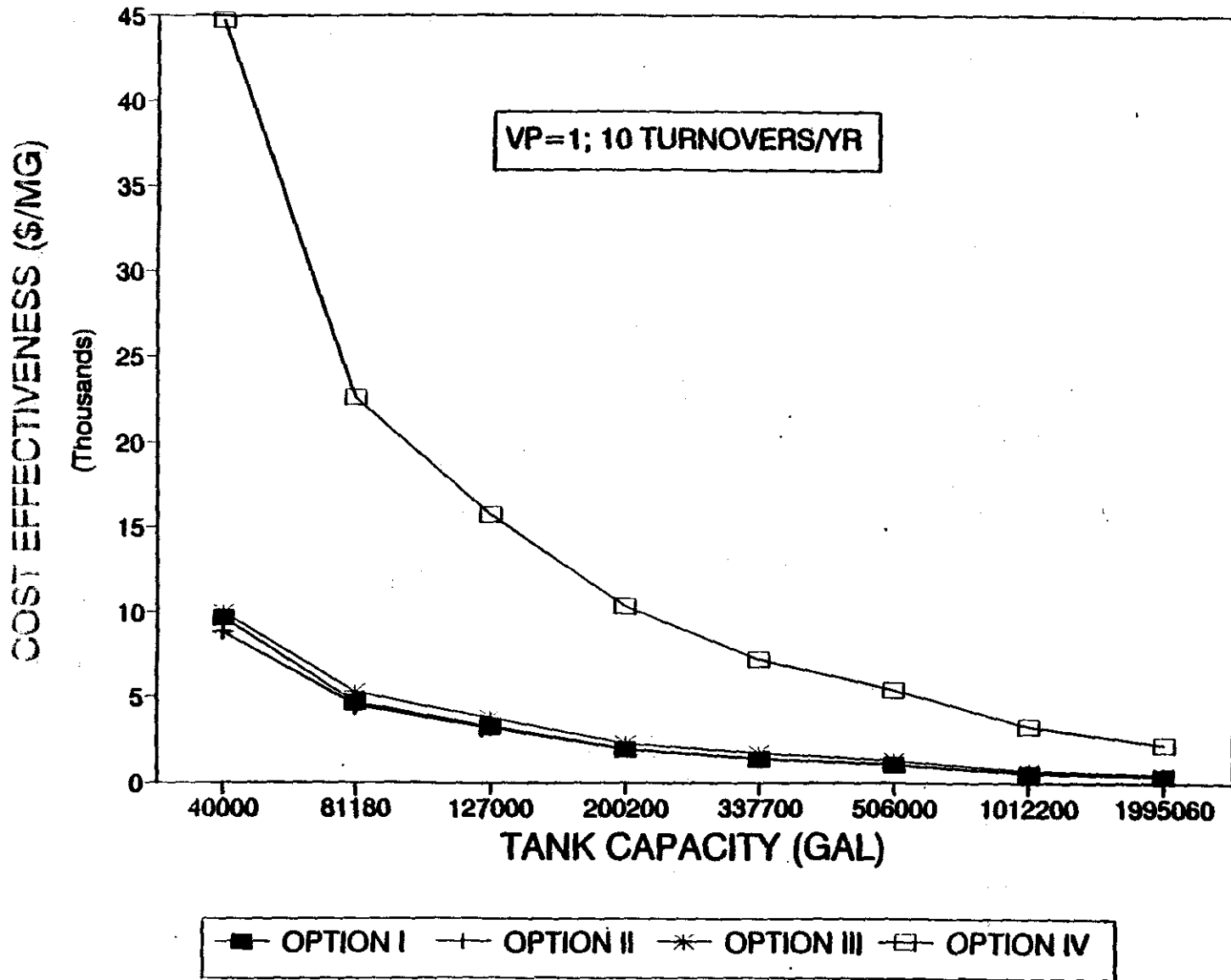

Figure 6-12. The cost-effectiveness of control options on fixed-roof tanks storing crude oil as a function of tank volume.

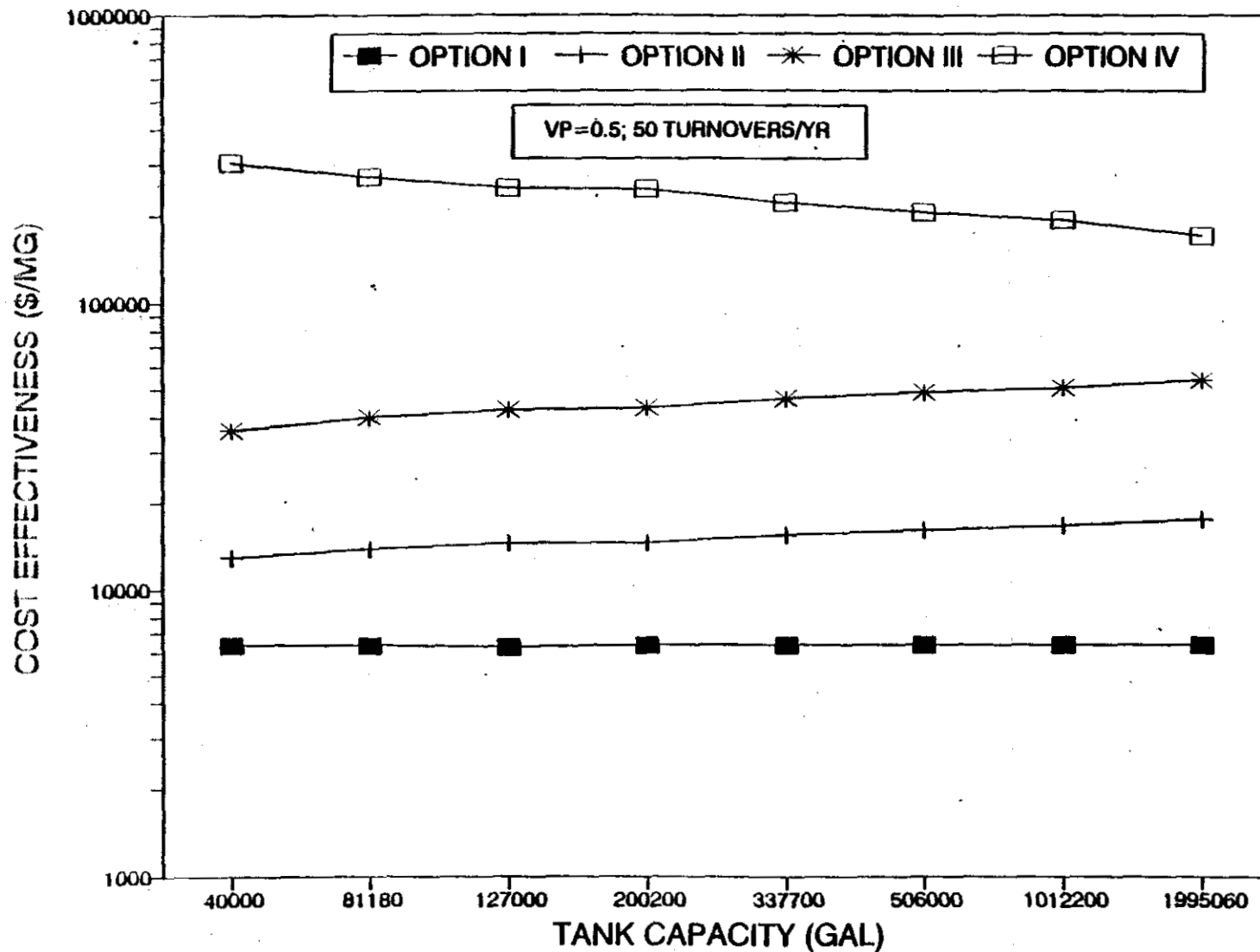

Figure 6-13. The cost-effectiveness of control options on internal floating roof tanks storing VOL as a function of tank volume.

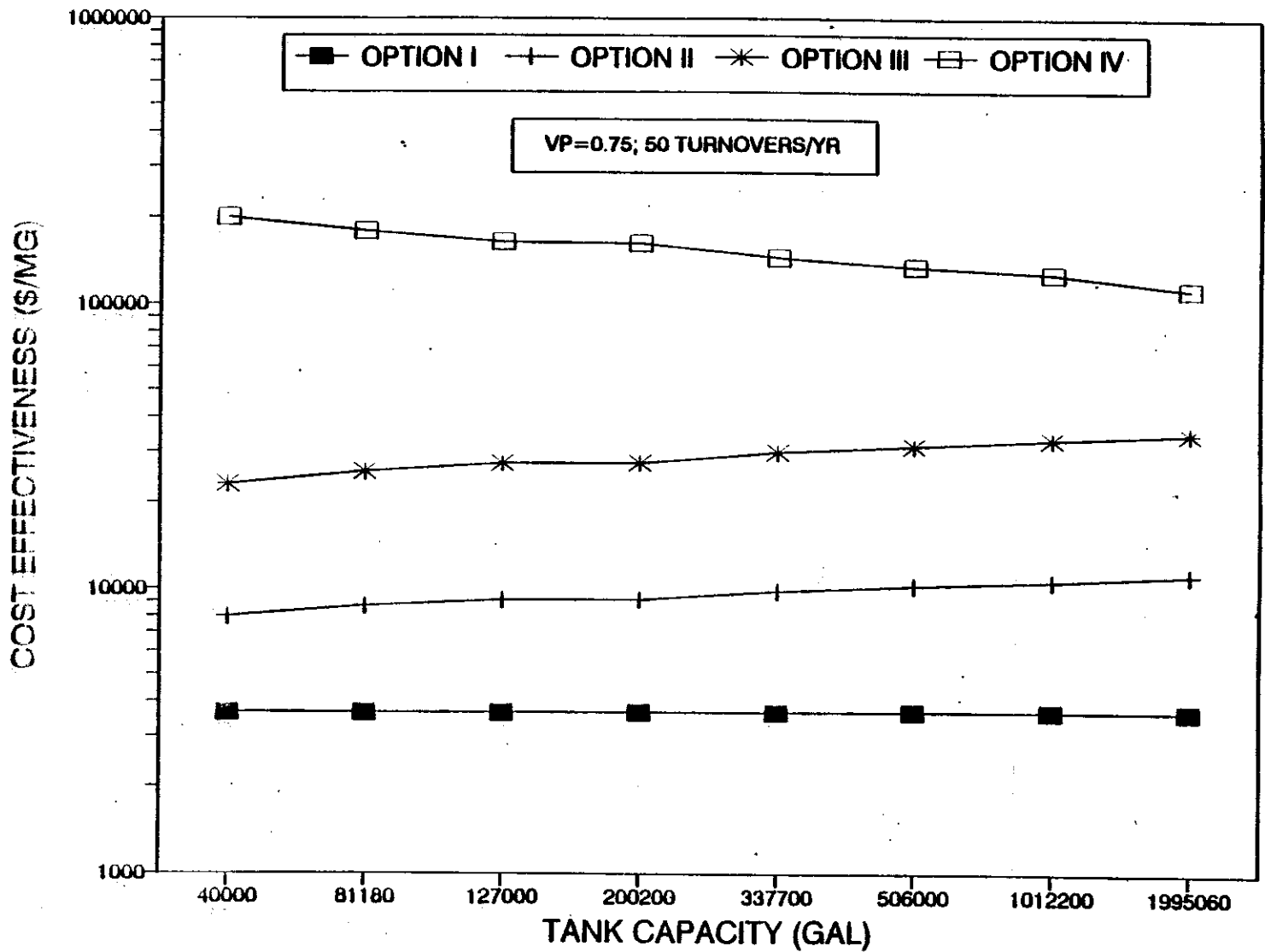

Figure 6-14. The cost-effectiveness of control options on internal floating roof tanks storing VOL as a function of tank volume.

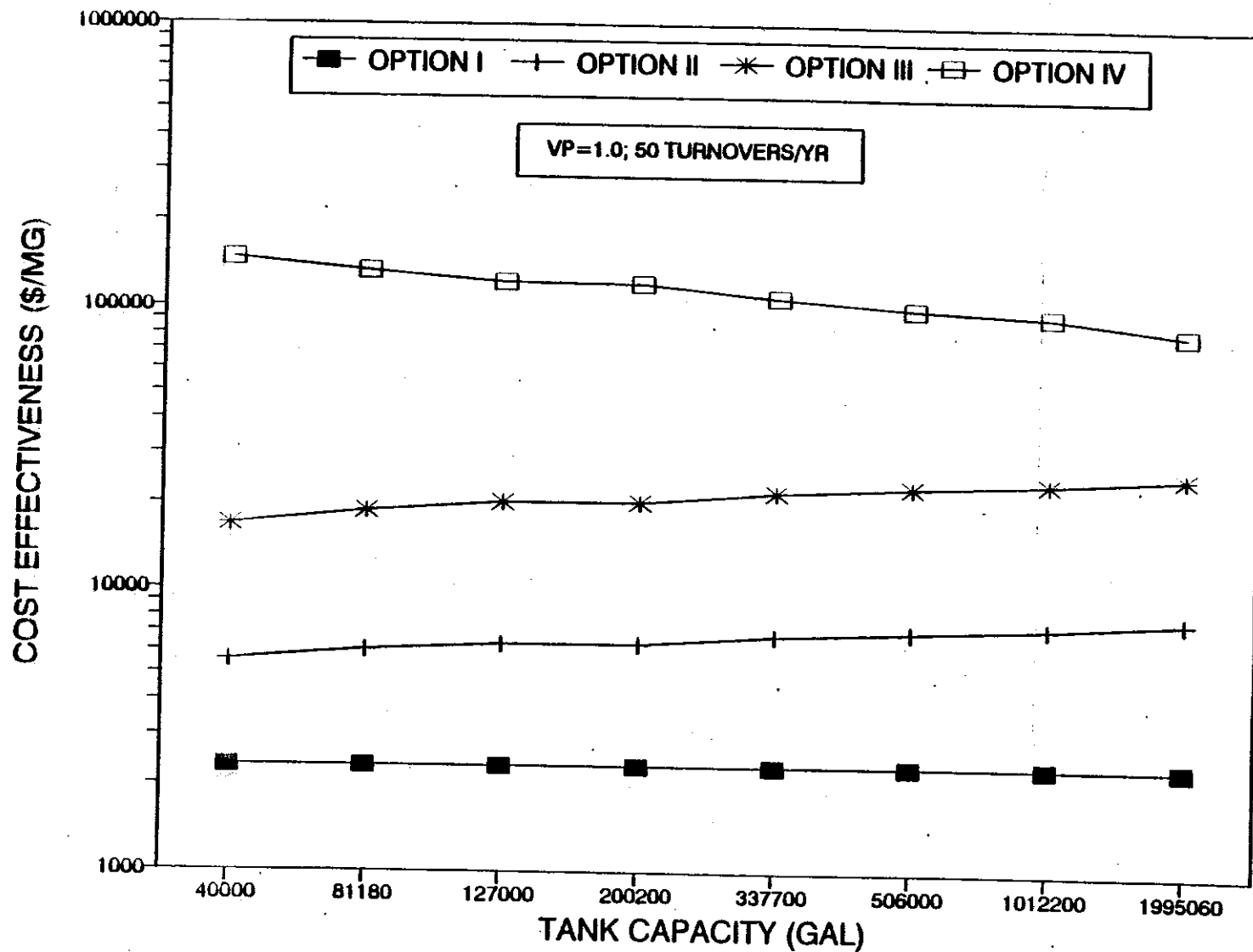

Figure 6-15. The cost-effectiveness of control options on internal floating roof tanks storing VOL as a function of tank volume.

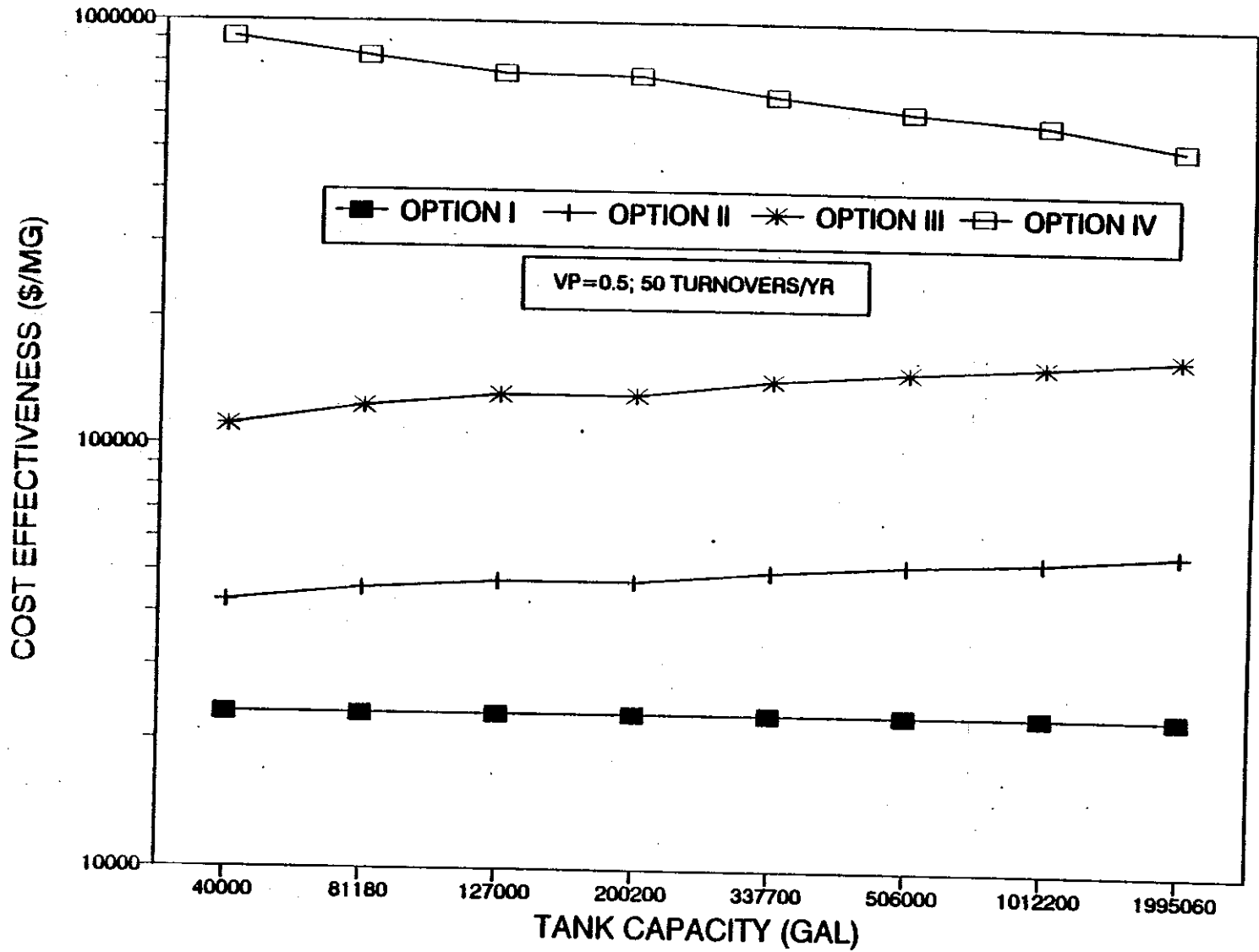

Figure 6-16. The cost-effectiveness of control options on internal floating roof tanks storing crude oil as a function of tank volume.

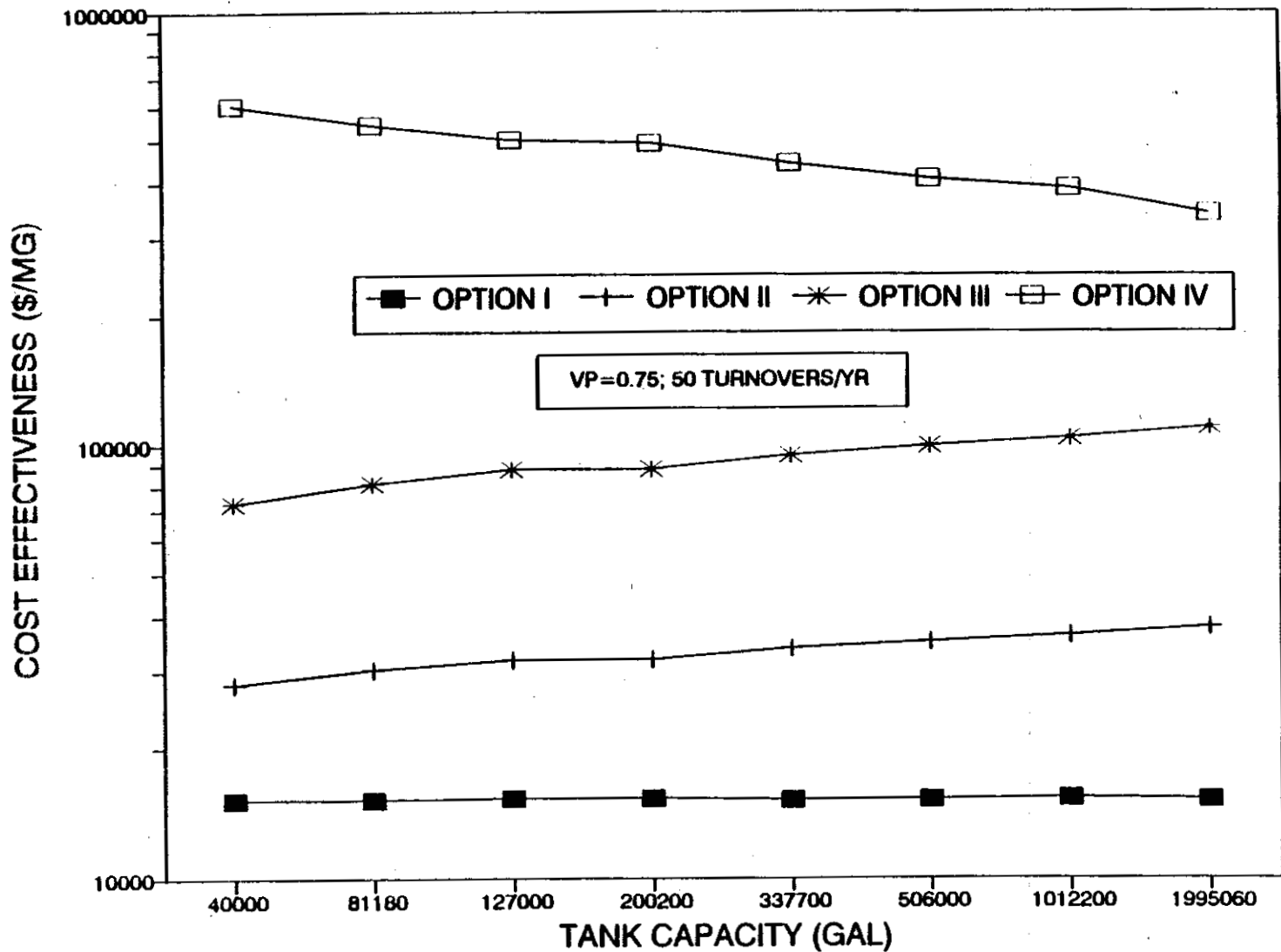

Figure 6-17. The cost-effectiveness of control options on internal floating roof tanks storing crude oil as a function of tank volume.

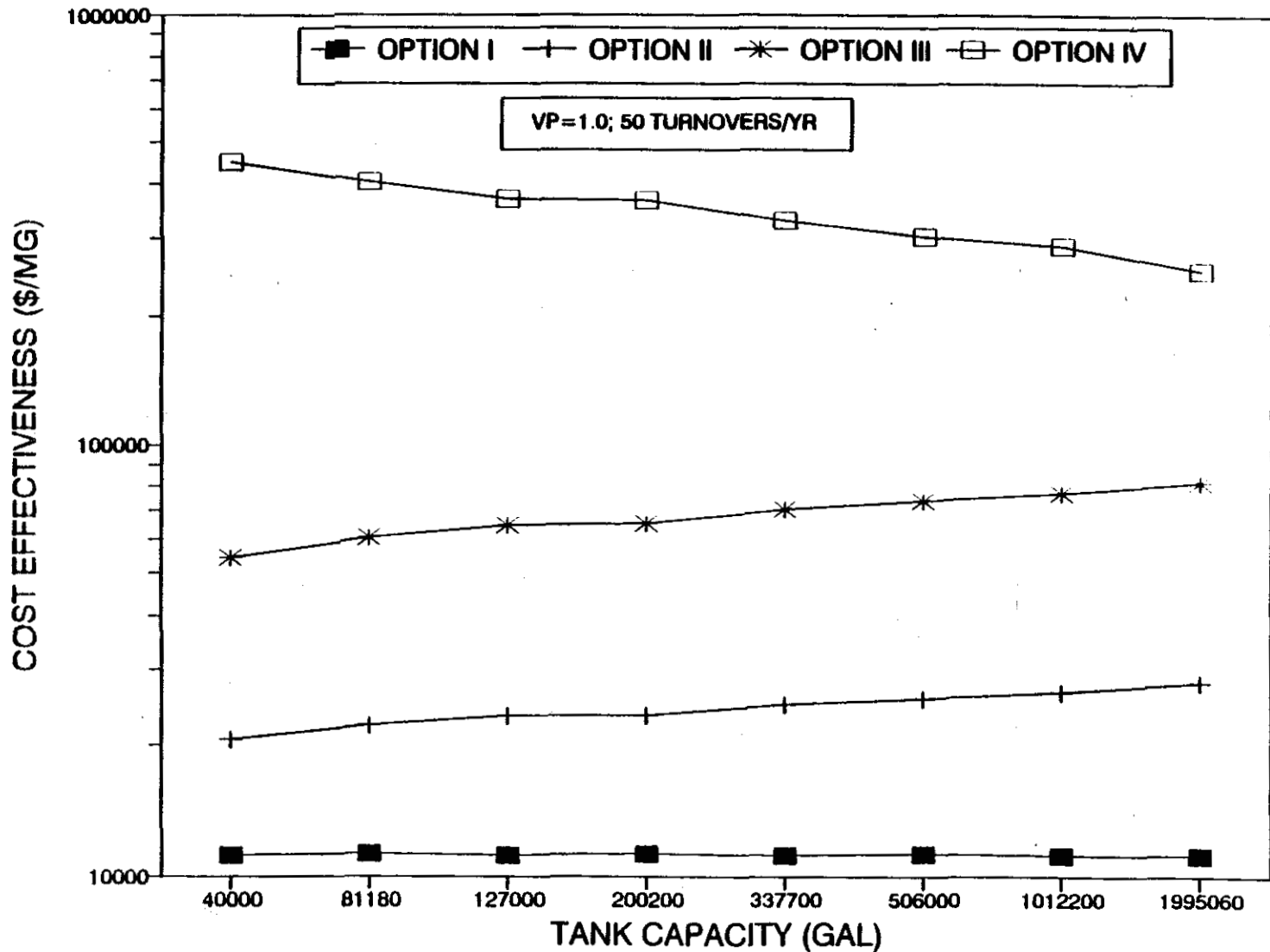

Figure 6-18. The cost-effectiveness of control options on internal floating roof tanks storing crude oil as a function of tank volume.

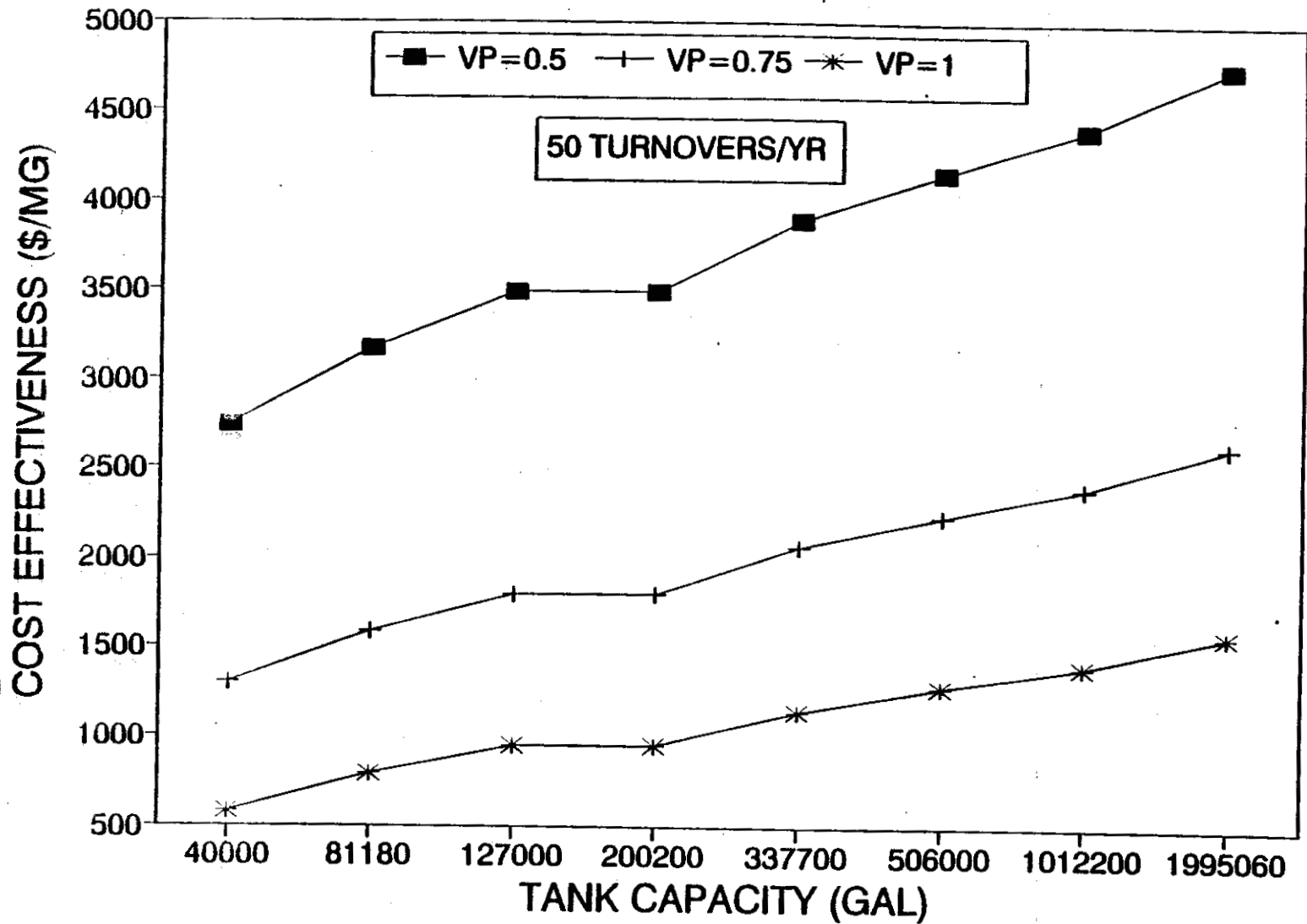

Figure 6-19. The cost-effectiveness of control options on external floating roof tanks equipped with mechanical shoe primary seals storing VOL as a function of tank volume and vapor pressure.

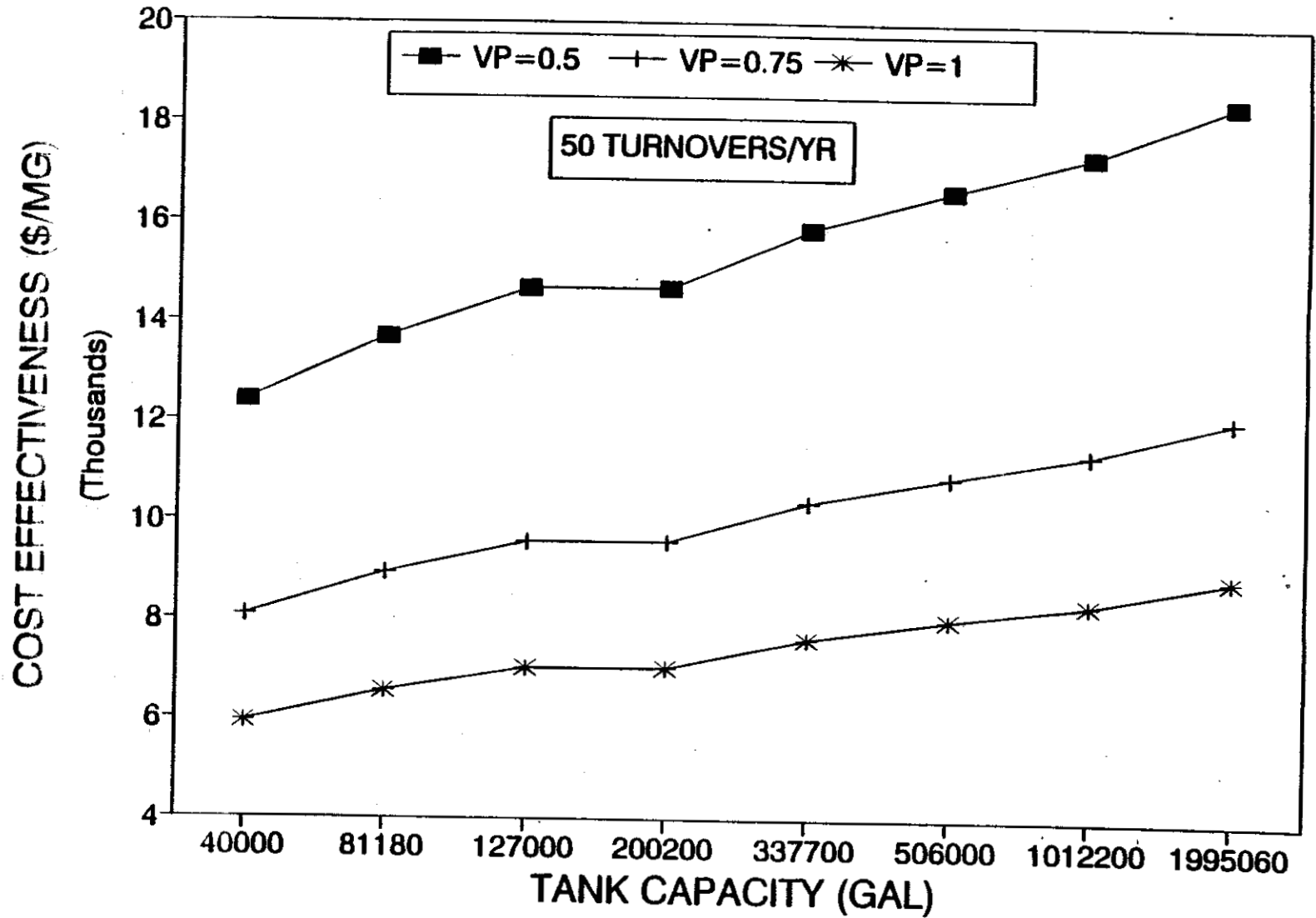

Figure 6-20. The cost-effectiveness of control options on external floating roof tanks equipped with mechanical shoe primary seals storing crude oil as a function of tank volume and vapor pressure.

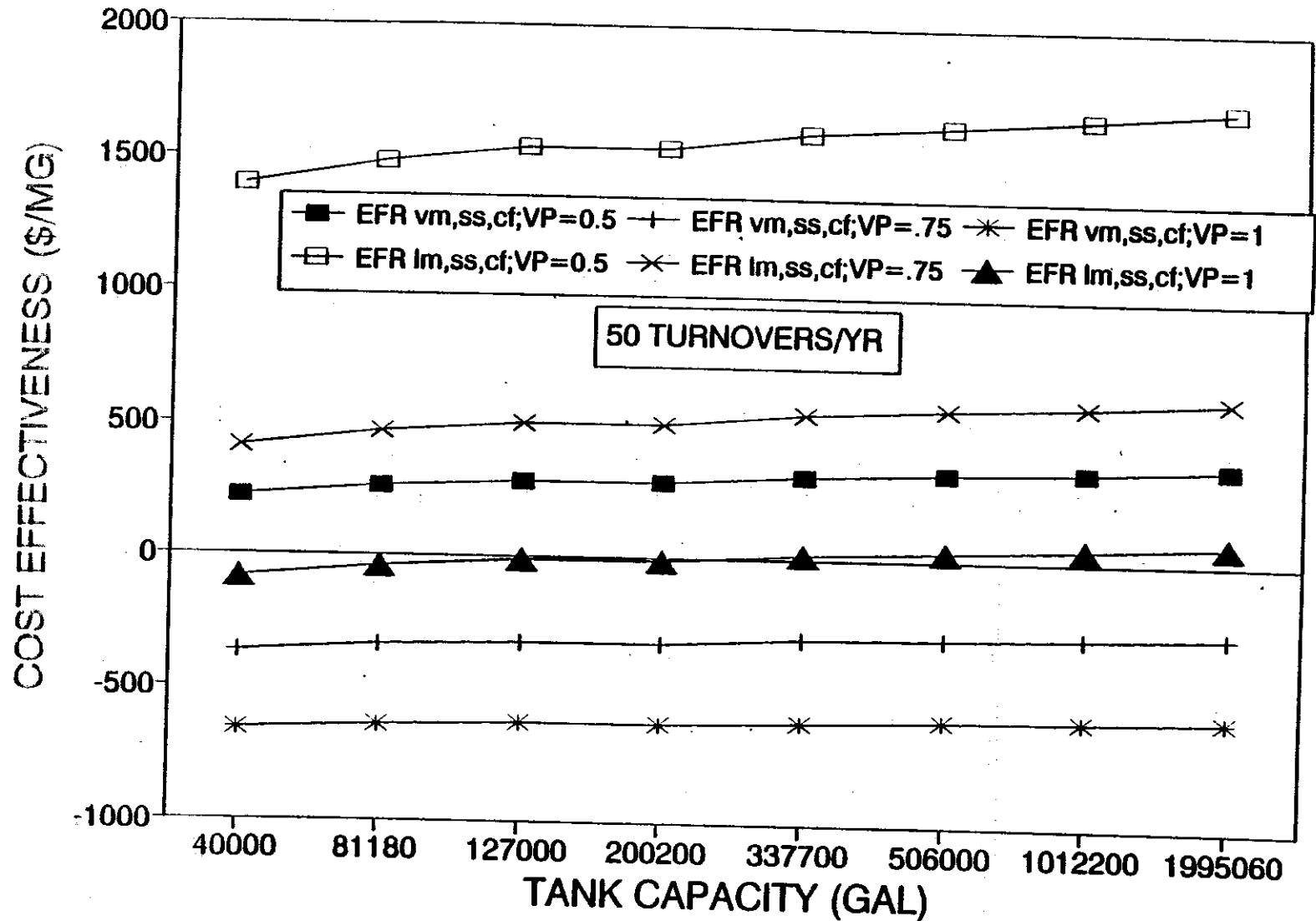

Figure 6-21. The cost-effectiveness of control options on external floating roof tanks equipped with vapor-mounted primary seals storing VOL as a function of tank volume and vapor pressure.

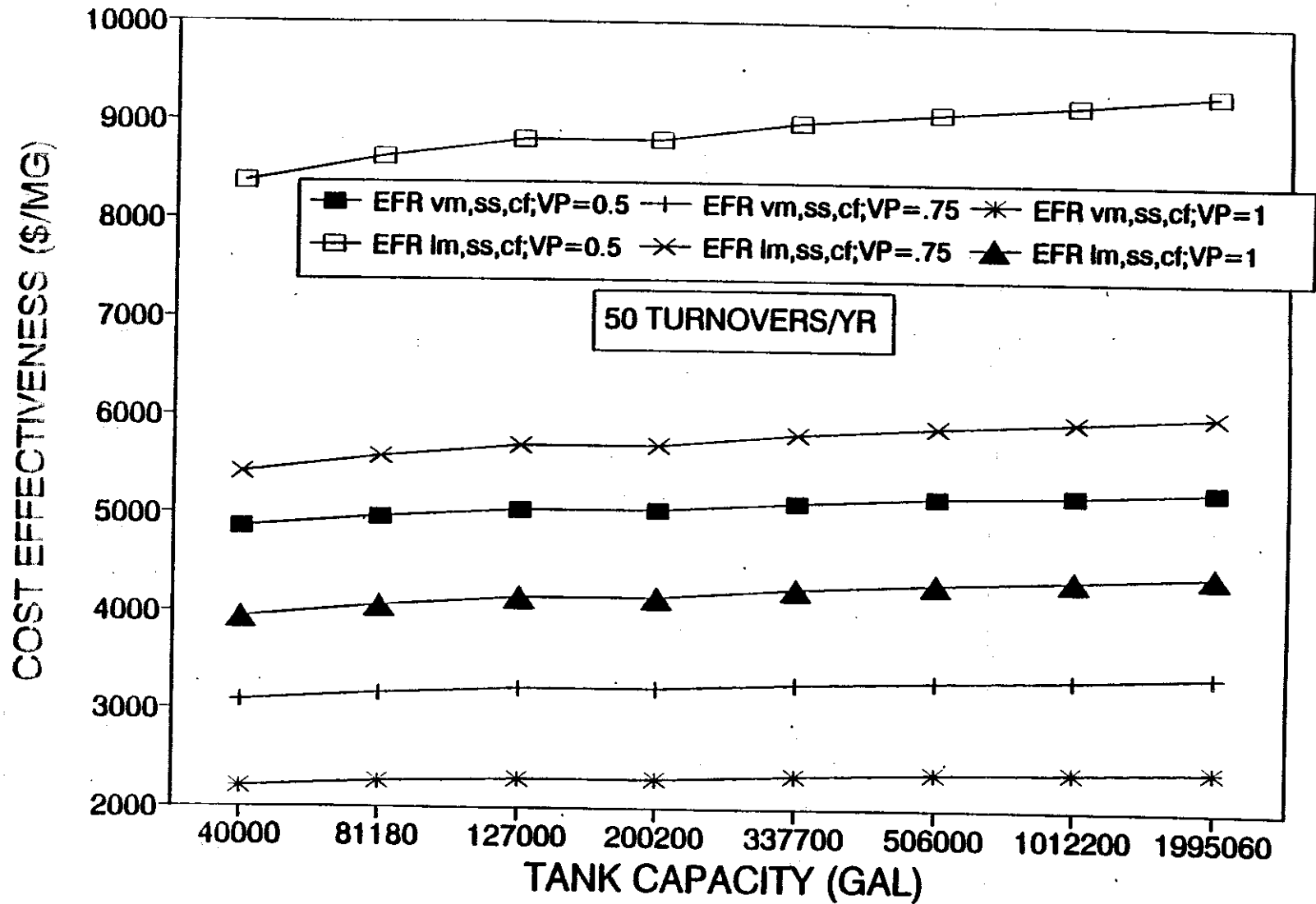

Figure 6-22. The cost-effectiveness of control options on external floating roof tanks equipped with vapor-mounted primary seals storing crude oil as a function of tank volume and vapor pressure.

TABLE 6-1. ESTIMATED INSTALLED CAPITAL COST OF
INTERNAL FLOATING ROOFS (1991 DOLLARS)

Tank diameter, m (ft)	Tank capacity, l (gal)	Basic roof cost aluminum, noncontact, \$ ^a	Basic cost of welded steel contact IFR's, \$ ^b	Cost (including retrofit) of welded steel contact IFR's, \$ ^c
3.7 (12)	38,420 (10,150)	6,923	36,650	46,970
4.6 (15)	80,060 (21,150)	7,510	38,475	49,475
6.1 (20)	213,500 (56,400)	8,670	41,975	54,595
7.6 (25)	333,610 (88,130)	9,894	45,850	59,310
9.1 (30)	720,600 (190,360)	10,816	49,650	65,070
10.7 (35)	980,810 (259,100)	11,949	53,825	70,945
12.2 (40)	1,281,030 (338,410)	13,505	58,750	77,990
15.2 (50)	2,001,630 (528,770)	16,770	66,975	90,445
18.3 (60)	3,843,090 (1,015,230)	20,048	76,525	105,985
30.5 (100)	11,120,070 (2,937,590)	38,960	132,170	189,040

^aEquation developed from cost data for any tank capacity: Cost (\$) = 3.19 (D²) + 7,734; where D = tank diameter in feet; with the correlation coefficient r² = 0.993. This correlation generates installed cost estimates for an aluminum noncontact internal floating roof with a vapor-mounted primary seal and a secondary seal.

^bEquation developed from cost data for any tank capacity: Cost (\$) = 9.46 (D²) + 40,013; where D = tank diameter in feet; with the correlation coefficient r² = 0.989. This correlation generates installed cost estimates for a welded steel contact internal floating roof and primary seal.

^cEquation developed from cost data for any tank capacity: Cost (\$) = 14.14 (D²) + 50,976; where D = tank diameter in feet; with the correlation coefficient r² = 0.992. This correlation generates installed cost estimates for replacing an aluminum noncontact IFR with a welded steel contact IFR.

TABLE 6-2. NATIONWIDE COST IMPACTS FOR FIXED-ROOF TANK OPTIONS

Control options/ cutoff values	Nationwide capital costs, \$ (millions)	Nationwide annual cost, \$/yr (millions)	Nationwide emissions reduction, Mg/yr (tons/yr)	Cost effectiveness, \$/Mg (\$/ton)
Control Option I^d				
VP = 0.5 ^a	280	30.7	51,960 (57,730)	590 (530)
VP = 0.75 ^b	222	24.3	47,950 (53,280)	510 (460)
VP = 1.0 ^c	163	17.9	41,970 (46,630)	430 (380)
Control Option II^e				
VP = 0.5 ^a	281	30.6	52,650 (58,500)	580 (520)
VP = 0.75 ^b	222	24.2	48,630 (54,030)	500 (450)
VP = 1.0 ^c	164	17.9	42,450 (47,170)	420 (380)
Control Option III^f				
VP = 0.5 ^a	295	34.4	52,780 (58,640)	650 (590)
VP = 0.75 ^b	234	27.2	48,670 (54,080)	560 (500)
VP = 1.0 ^c	172	20.0	42,540 (47,270)	470 (420)
Control Option IV^g				
VP = 0.5 ^a	513	91.4	53,690 (59,650)	1,700 (1,530)
VP = 0.75 ^b	406	72.3	49,460 (54,960)	1,460 (1,320)
VP = 1.0 ^c	299	53.3	43,170 (47,970)	1,230 (1,110)

^aBased on a vapor pressure cutoff value of 0.5 psia and a tank capacity cutoff value of 40,000 gallons.

^bBased on a vapor pressure cutoff value of 0.75 psia and a tank capacity cutoff value of 40,000 gallons.

^cBased on a vapor pressure cutoff value of 1.0 psia and a tank capacity cutoff value of 40,000 gallons.

^dControl Option I = installation of an aluminum noncontact IFR with vapor-mounted primary seals and uncontrolled fittings.

^eControl Option II = installation of an aluminum noncontact IFR with vapor-mounted primary seals, secondary seals, and controlled fittings.

^fControl Option III = installation of an aluminum noncontact IFR with liquid-mounted primary seals, secondary seals, and controlled fittings.

^gControl Option IV = installation of a welded steel contact IFR with liquid-mounted primary seals, secondary seals, and controlled fittings.

TABLE 6-3. NATIONWIDE COST IMPACTS FOR INTERNAL FLOATING ROOF TANK OPTIONS

Control options/ cutoff values	Nationwide capital costs, \$ (millions)	Nationwide annual cost, \$/yr (millions)	Nationwide emissions reduction, Mg/yr (tons/yr)	Cost effectiveness, \$/Mg (\$/ton)
Control Option I^a				
VP = 0.5 ^b	4.1	0.4	860 (950)	470 (420)
VP = 0.75 ^c	4.0	0.4	850 (940)	470 (420)
VP = 1.0 ^d	3.8	0.4	850 (940)	470 (420)
VP = 1.5 ^e	3.7	0.4	840 (920)	480 (430)
Control Option II^f				
VP = 0.5 ^b	42.9	8.8	4,750 (5,230)	1,850 (1,680)
VP = 0.75 ^c	41.6	8.4	4,720 (5,190)	1,780 (1,620)
VP = 1.0 ^d	40.4	8.2	4,690 (5,160)	1,750 (1,590)
VP = 1.5 ^e	38.9	7.9	4,630 (5,090)	1,710 (1,550)
Control Option III^g				
VP = 0.5 ^b	144.2	35	6,290 (6,920)	5,560 (5,060)
VP = 0.75 ^c	140.0	34	6,260 (6,890)	5,430 (4,930)
VP = 1.0 ^d	135.9	33	6,210 (6,830)	5,310 (4,830)
VP = 1.5 ^e	130.9	32	6,130 (6,740)	5,220 (4,750)
Control Option IV^h				
VP = 0.5 ^b	876.5	226	11,870 (13,060)	19,040 (17,300)
VP = 0.75 ^c	851.3	219	11,810 (12,990)	18,540 (16,860)
VP = 1.0 ^d	826.2	213	11,720 (12,890)	18,170 (16,520)
VP = 1.5 ^e	795.6	205	11,570 (12,730)	17,720 (16,100)

^aControl Option I = control fittings.

^bBased on a vapor pressure cutoff value of 0.5 psia and a tank capacity cutoff value of 40,000 gallons and greater.

^cBased on a vapor pressure cutoff value of 0.75 psia and a tank capacity cutoff value of 40,000 gallons and greater.

^dBased on a vapor pressure cutoff value of 1.0 psia and a tank capacity cutoff value of 40,000 gallons and greater.

^eBased on a vapor pressure cutoff value of 1.5 psia and a tank capacity cutoff value of 40,000 gallons and greater.

^fControl Option II = control fittings and add a secondary seal.

^gControl Option III = replace vapor-mounted primary seal with liquid-mounted primary seal, secondary seals, and controlled fittings.

^hControl Option IV = replace noncontact IFR with a welded steel contact IFR with liquid-mounted primary seals, secondary seals, and controlled fittings.

TABLE 6-4. NATIONWIDE COST IMPACTS FOR EXTERNAL FLOATING ROOF TANK OPTIONS

Control options/ cutoff values	Nationwide capital costs, \$ (millions)	Nationwide annual cost, \$/yr (millions)	Nationwide emissions reduction, Mg/yr (tons/yr)	Cost effectiveness, \$/Mg (\$/ton)
Mechanical shoe primary seals ^a				
<u>Control Option I</u> ^b				
VP = 0.5 ^c	13.4	-1.0	11,050 (12,160)	-90 (-80)
VP = 0.75 ^d	11.7	-1.3	10,910 (12,000)	-120 (-110)
VP = 1.0 ^e	10.0	-1.7	10,710 (11,780)	-160 (-140)
VP = 1.5 ^f	4.8	-2.8	9,880 (10,870)	-280 (-260)

^aFor base case of external floating roof with mechanical shoe primary seals. Assumes all EFR tanks are equipped with mechanical shoe primary seals.

^bOption I = Control fittings and add a secondary seal.

^cBased on a vapor pressure cutoff value of 0.5 psia and a tank capacity cutoff value of 40,000 gallons.

^dBased on a vapor pressure cutoff value of 0.75 psia and a tank capacity cutoff value of 40,000 gallons.

^eBased on a vapor pressure cutoff value of 1.0 psia and a tank capacity cutoff value of 40,000 gallons.

^fBased on a vapor pressure cutoff value of 1.5 psia and a tank capacity cutoff value of 40,000 gallons.

6.6 REFERENCES

1. Cost Enclosure for Storage Tanks, Ultraflote Corporation. Houston, Texas. Prepared for U. S. Environmental Protection Agency, Research Triangle Park, North Carolina. May 22, 1991.
2. Cost Enclosure for Storage Tanks, Chicago Bridge and Iron Corporation. Oak Brook, Illinois. Prepared for U. S. Environmental Protection Agency, Research Triangle Park, North Carolina. April 8, 1991.
3. Cost Enclosure for Storage Tanks, Pittsburgh-Des Moines Corporation. Pittsburgh, Pennsylvania. Prepared for U. S. Environmental Protection Agency, Research Triangle Park, North Carolina. March 6, 1991.
4. Telecon. deOlloqui, V., MRI, to McManus, E., Four Seasons Industrial Services. Greensboro, North Carolina. June 1991. Information on cleaning and degassing of storage tanks.
5. EAB Control Cost Manual (Fourth Edition), U. S. Environmental Protection Agency, Research Triangle Park, North Carolina. Publication No. EPA 450/3-90-006. January 1990.
6. Hazardous Air Pollutant Emissions from Process Units in the Synthetic Organic Chemical Manufacturing Industry--Background Information for Proposed Standards. U. S. Environmental Protection Agency, Research Triangle Park, North Carolina. Publication No. EPA 453/D-92-0168. November 1992.
7. Energy Information Administration. Petroleum Marketing Monthly and Petroleum Marketing Annual. U. S. Department of Energy, Washington, D.C. 1987-1990.



APPENDIX A
VOL STORAGE VESSEL EXAMPLE RULE

This appendix presents an example rule limiting VOC emissions from VOL storage vessels. The example rule is for informational purposes only; it is intended to provide information concerning factors that need to be considered in writing a rule to ensure that it is enforceable.

This example rule is general in nature; that is, the applicability of the rule, and thus the stringency, are determined when the volume and vapor pressure "cutoffs" are chosen by a State or local agency. As mentioned in Chapter 1, this document does not contain a recommendation on RACT; therefore, the cutoffs in the example rule appear as variables.

The general framework presented in this example rule is consistent with the NSPS(Kb) and the Hazardous Organic NESHAP (HON) proposed rule (57 FR 62608) for Synthetic Organic Chemical Manufacturing Industry (SOCMI) plants.



Control of Volatile Organic Compound Emissions from Volatile Organic Liquid Storage Vessels

§XX.110b Applicability and designation of affected facility.

(a) Except as provided in paragraphs (b), (c), and (d) of this section, the affected facility to which this rule applies is each storage vessel with a capacity greater than or equal to [Volume cutoff] gallons (gal) that is used to store volatile organic liquids (VOL's).

(b) Except as specified in paragraphs (a) and (b) of §XX.116b storage vessels with design capacity less than [Volume cutoff] gal are exempt from the provisions of this rule.

(c) Except as specified in paragraphs (a) and (b) of §XX.116b, vessels with a capacity greater than or equal to [Volume cutoff] gal storing a liquid with a maximum true vapor pressure less than [Vapor pressure cutoff 1] psia are exempt from the provisions of this rule.

(d) This rule does not apply to the following:

[This section includes exemptions from the rule.]

§XX.111b Definitions.

Terms used in this rule are defined as follows:

(a) "Bulk gasoline plant" means any gasoline distribution facility that has a gasoline throughput less than or equal to 75,700 liters per day. Gasoline throughput shall be the maximum calculated design throughput as may be limited by compliance with an enforceable condition under Federal requirement or Federal, State or local law, and discoverable by the Agency and any other person.

(b) "Condensate" means hydrocarbon liquid separated from natural gas that condenses due to changes in the temperature or pressure, or both, and remains liquid at standard conditions.

(c) "Custody transfer" means the transfer of produced petroleum and/or condensate, after processing and/or treatment in

the producing operations, from storage vessels or automatic transfer facilities to pipelines or any other forms of transportation.

(d) "Fill" means the introduction of VOL into a storage vessel but not necessarily to complete capacity.

(e) "Gasoline service station" means any site where gasoline is dispensed to motor vehicle fuel tanks from stationary storage tanks.

(f) "Maximum true vapor pressure" means the equilibrium partial pressure exerted by the stored VOL, at the temperature equal to the highest calendar-month average of the VOL storage temperature for VOL's stored above or below the ambient temperature or at the local maximum monthly average temperature as reported by the National Weather Service for VOL's stored at the ambient temperature, as determined:

(1) In accordance with methods described in American Petroleum Institute Bulletin 2517, Evaporation Loss From External Floating Roof Tanks;

(2) As obtained from standard reference texts; or

(3) As determined by ASTM Method D2879-83;

(4) Any other method approved by the Agency.

(g) "Reid vapor pressure" means the absolute vapor pressure of volatile crude oil and volatile nonviscous petroleum liquids except liquified petroleum gases, as determined by ASTM D323-82 (incorporated by reference—see §XX.17).

(h) "Petroleum" means the crude oil removed from the earth and the oils derived from tar sands, shale, and coal.

(i) "Petroleum liquids" means petroleum, condensate, and any finished or intermediate products manufactured in a petroleum refinery.

(j) "Storage vessel" means each tank, reservoir, or container used for the storage of volatile organic liquids but does not include:

(1) Frames, housing, auxiliary supports, or other components that are not directly involved in the containment of liquids or vapors; or

(2) Subsurface caverns or porous rock reservoirs.

(k) "Volatile organic liquid" (VOL) means any organic liquid which can emit volatile organic compounds into the atmosphere except those VOL's that emit only those compounds which the Agency has determined do not contribute appreciably to the formation of ozone. These compounds are identified in EPA statements on ozone abatement policy for SIP revisions (42 FR 35314, 44 FR 32042, 45 FR 32424, and 45 FR 48941).

(l) "Waste" means any liquid resulting from industrial, commercial, mining or agricultural operations, or from community activities that is discarded or is being accumulated, stored, or physically, chemically, or biologically treated prior to being discarded or recycled.

§XX.112b Standard for volatile organic compounds (VOC).

(a) The owner or operator of each storage vessel either with a design capacity greater than or equal to [Volume cutoff] gal containing a VOL that, as stored, has a maximum true vapor pressure equal to or greater than [Vapor pressure cutoff 2] psia but less than 11.1 psia shall reduce VOC emissions as follows:

(1) Each fixed roof tank shall be equipped with an internal floating roof meeting the following specifications or a vapor control system meeting the specifications contained in paragraph (4).

(i) The internal floating roof shall rest or float on the liquid surface (but not necessarily in complete contact with it) inside a storage vessel that has a fixed roof. The internal floating roof shall be floating on the liquid surface at all times, except during initial fill and during those intervals when the storage vessel is completely emptied or subsequently emptied and refilled. When the roof is resting on the leg supports, the process of filling, emptying, or refilling shall be continuous and shall be accomplished as rapidly as possible.

(ii) Each internal floating roof shall be equipped with one of the following closure devices between the wall of the storage vessel and the edge of the internal floating roof:

(A) A foam-or liquid-filled seal mounted in contact with the liquid (liquid-mounted seal). A liquid-mounted seal means a foam-or liquid-filled seal mounted in contact with the liquid between the wall of the storage vessel and the floating roof continuously around the circumference of the tank.

(B) Two seals mounted one above the other so that each forms a continuous closure that completely covers the space between the wall of the storage vessel and the edge of the internal floating roof. The lower seal may be vapor-mounted, but both must be continuous.

(C) A mechanical shoe seal. A mechanical shoe seal is a metal sheet held vertically against the wall of the storage vessel by springs or weighted levers and is connected by braces to the floating roof. A flexible coated fabric (envelope) spans the annular space between the metal sheet and the floating roof.

(iii) Each opening in a noncontact interval floating roof except for automatic bleeder vents (vacuum breaker vents) and the rim space vents is to provide a projection below the liquid surface.

(iv) Each opening in the internal floating roof except for leg sleeves, automatic bleeder vents, rim space vents, column wells, ladder wells, sample wells, and stub drains is to be equipped with a cover or lid which is to be maintained in a closed position at all times (i.e., no visible gap) except when the device is in actual use. The cover or lid shall be equipped with a gasket. Covers on each access hatch and automatic gauge float well shall be bolted except when they are in use.

(v) Automatic bleeder vents shall be equipped with a gasket and are to be closed at all times when the roof is floating except when the roof is being floated off or is being landed on the roof leg supports.

(vi) Rim space vents shall be equipped with a gasket and are to be set to open only when the internal floating roof is not floating or at the manufacturer's recommended setting.

(vii) Each penetration of the internal floating roof for the purpose of sampling shall be a sample well. The sample well shall have a slit fabric cover that covers at least 90 percent of the opening.

(viii) Each penetration of the internal floating roof that allows for passage of a ladder shall have a gasketed sliding cover.

(2) After the next scheduled tank cleaning, but no later than 10 years after the effective date of this rule, each internal floating roof tank shall meet the following specifications:

(i) The internal floating roof shall be floating on the liquid surface at all times except during those intervals when the storage vessel is completely emptied or subsequently emptied and refilled. When the roof is resting on the leg supports, the process of filling, emptying, or refilling shall be continuous and shall be accomplished as rapidly as possible.

(ii) Each internal floating roof shall be equipped with one of the following closure devices between the wall of the storage vessel and the edge of the internal floating roof:

(A) A foam-or liquid-filled seal mounted in contact with the liquid (liquid-mounted seal). A liquid-mounted seal means a foam-or liquid-filled seal mounted in contact with the liquid between the wall of the storage vessel and the floating roof continuously around the circumference of the tank.

(B) Two seals mounted one above the other so that each forms a continuous closure that completely covers the space between the wall of the storage vessel and the edge of the internal floating roof. The lower seal may be vapor-mounted, but both must be continuous.

(C) A mechanical shoe seal.

(iii) Each opening in a noncontact interval floating roof except for automatic bleeder vents (vacuum breaker vents) and the

rim space vents is to provide a projection below the liquid surface.

(iv) Each opening in the internal floating roof except for leg sleeves, automatic bleeder vents, rim space vents, column wells, ladder wells, sample wells, and stub drains is to be equipped with a cover or lid which is to be maintained in a closed position at all times (i.e., no visible gap) except when the device is in actual use. The cover or lid shall be equipped with a gasket. Covers on each access hatch and automatic gauge float well shall be bolted except when they are in use.

(v) Automatic bleeder vents shall be equipped with a gasket and are to be closed at all times when the roof is floating except when the roof is being floated off or is being landed on the roof leg supports.

(vi) Rim space vents shall be equipped with a gasket and are to be set to open only when the internal floating roof is not floating or at the manufacturer's recommended setting.

(vii) Each penetration of the internal floating roof that allows for passage of a ladder shall have a gasketed sliding cover.

(3) Each external floating roof tank shall meet the following specifications:

(i) Each external floating roof shall be equipped with a closure device between the wall of the storage vessel and the roof edge. The closure device is to consist of two seals, one above the other. The lower seal is referred to as the primary seal, and the upper seal is referred to as the secondary seal.

(A) Except as provided in §XX.113b(b)(4), the primary seal shall completely cover the annular space between the edge of the floating roof and tank wall and shall be either a liquid mounted seal or a shoe seal.

(B) The secondary seal shall completely cover the annular space between the external floating roof and the wall of the storage vessel in a continuous fashion except as allowed in §XX:113b(b)(4).

(C) The tank shall be equipped with the closure device after the next scheduled tank cleaning, but no later than 10 years after the effective date of this rule.

(ii) Except for automatic bleeder vents and rim space vents, each opening in a noncontact external floating roof shall provide a projection below the liquid surface. Except for automatic bleeder vents, rim space vents, roof drains, and leg sleeves, each opening in the roof is to be equipped with a gasketed cover, seal, or lid that is to be maintained in a closed position at all times (i.e., no visible gap) except when the device is in actual use. Automatic bleeder vents are to be closed at all times when the roof is floating except when the roof is being floated off or is being landed on the roof leg supports. Rim vents are to be set to open when the roof is being floated off the roof leg supports or at the manufacturer's recommended setting. Automatic bleeder vents and rim space vents are to be gasketed. Each emergency roof drain is to be provided with a slotted membrane fabric cover that covers at least 90 percent of the area of the opening.

(iii) The roof shall be floating on the liquid at all times (i.e., off the roof leg supports) except when the tank is completely emptied and subsequently refilled. The process of filling, emptying, or refilling when the roof is resting on the leg supports shall be continuous and shall be accomplished as rapidly as possible.

(4) A closed vent system and control device meeting the following specifications:

(i) The closed vent system shall be designed to collect all VOC vapors and gases discharged from the storage vessel and operated with no detectable emission as indicated by an instrument reading of less than 500 ppm above background and visual inspections, as determined by the methods specified in Part 60, Subpart VV, §60.485(c).

(ii) The control device shall be designed and operated to reduce inlet VOC emissions by 95 percent or greater. If a flare is used as the control device, it shall meet the specifications

described in the general control device requirements (§60.18) of the General Provisions.

(5) A system equivalent to those described in paragraphs (a) (1), (a) (2), (a) (3), or (a) (4) of this section as provided in §XX.114b of this rule.

(b) The owner or operator of each storage vessel with a design capacity greater than or equal to [Volume cutoff] gal which contains a VOL that, as stored, has a maximum true vapor pressure greater than or equal to 11.1 psia shall equip each storage vessel with one of the following:

(1) A closed vent system and control device as specified in §XX.112b(a) (3).

(2) A system equivalent to that described in paragraph (b) (1) as provided in §XX.114b of this rule.

§XX.113b Testing and procedures.

The owner or operator of each storage vessel as specified in §XX.112b(a) shall meet the requirements of paragraph (a), (b), or (c) of this section. The applicable paragraph for a particular storage vessel depends on the control equipment installed to meet the requirements of §XX.112b.

(a) After installing the control equipment required to meet §XX.112b(a) (1) or (2) (permanently affixed roof and internal floating roof), each owner or operator shall:

(1) Visually inspect the internal floating roof, the primary seal, and the secondary seal (if one is in service), prior to filling the storage vessel with VOL. If there are holes, tears, or other openings in the primary seal, the secondary seal, or the seal fabric or defects in the internal floating roof, or both, the owner or operator shall repair the items before filling the storage vessel.

(2) For vessels equipped with a liquid-mounted or mechanical shoe primary seal, visually inspect the internal floating roof and the primary seal or the secondary seal (if one is in service) through manholes and roof hatches on the fixed

roof at least once every 12 months after initial fill. If the internal floating roof is not resting on the surface of the VOL inside the storage vessel, or there is liquid accumulated on the roof, or the seal is detached, or there are holes or tears in the seal fabric, the owner or operator shall repair the items or empty and remove the storage vessel from service within 45 days. If a failure that is detected during inspections required in this paragraph cannot be repaired within 45 days and if the vessel cannot be emptied within 45 days, a 30-day extension may be requested from the Agency in the inspection report required in §XX.115b(a)(3). Such a request for an extension must document that alternate storage capacity is unavailable and specify a schedule of actions the company will take that will assure that the control equipment will be repaired or the vessel will be emptied as soon as possible.

(3) For vessels equipped with both primary and secondary seals:

(i) Visually inspect the vessel as specified in paragraph (a)(4) of this section at least every 5 years; or

(ii) Visually inspect the vessel as specified in paragraph (a)(2) of this section.

(4) Visually inspect the internal floating roof, the primary seal, the secondary seal (if one is in service), gaskets, slotted membranes and sleeve seals (if any) each time the storage vessel is emptied and degassed. If the internal floating roof has defects, the primary seal has holes, tears, or other openings in the seal or the seal fabric, or the secondary seal has holes, tears, or other openings in the seal or the seal fabric, or the gaskets no longer close off the liquid surfaces from the atmosphere, or the slotted membrane has more than 10 percent open area, the owner or operator shall repair the items as necessary so that none of the conditions specified in this paragraph exist before refilling the storage vessel with VOL. In no event shall inspections conducted in accordance with this provision occur at intervals greater than 10 years in the case of vessels conducting the annual visual inspection as specified in paragraphs (a)(2)

and (a) (3) (ii) of this section and at intervals no greater than 5 years in the case of vessels specified in paragraph (a) (3) (i) of this section.

(5) Notify the Agency in writing at least 30 days prior to the filling or refilling of each storage vessel for which an inspection is required by paragraphs (a) (1) and (a) (4) of this section to afford the Agency the opportunity to have an observer present. If the inspection required by paragraph (a) (4) of this section is not planned and the owner or operator could not have known about the inspection 30 days in advance or refilling the tank, the owner or operator shall notify the Agency at least 7 days prior to the refilling of the storage vessel. Notification shall be made by telephone immediately followed by written documentation demonstrating why the inspection was unplanned. Alternatively, this notification including the written documentation may be made in writing and sent by express mail so that it is received by the Agency at least 7 days prior to the refilling.

(b) The owner or operator of external floating roof tanks shall:

(1) Determine the gap areas and maximum gap widths, between the primary seal and the wall of the storage vessel and between the second seal and the wall of the storage vessel according to the following frequency.

(i) Measurements of gaps between the tank wall and the primary seal (seal gaps) shall be performed during the hydrostatic testing of the vessel or within 60 days of the initial fill with VOL and at least once every 5 years thereafter.

(ii) Measurements of gaps between the tank wall and the secondary seal shall be performed within 60 days of the initial fill with VOL and at least once per year thereafter.

(iii) If any source ceases to store VOL for a period of 1 year or more, subsequent introduction of VOL into the vessel shall be considered an initial fill for the purposes of paragraphs (b) (1) (i) and (b) (1) (ii) of this section.

(2) Determine gap widths and areas in the primary and secondary seals individually by the following procedures:

(i) Measure seal gaps, if any, at one or more floating roof levels when the roof is floating off the roof leg supports.

(ii) Measure seal gaps around the entire circumference of the tank in each place where a 1/8 inch (in) diameter uniform probe passes freely (without forcing or binding against seal) between the seal and the wall of the storage vessel and measure the circumferential distance of each such location.

(iii) The total surface area of each gap described in paragraph (b) (2) (ii) of this section shall be determined by using probes of various widths to measure accurately the actual distance from the tank wall to the seal and multiplying each such width by its respective circumferential distance.

(3) Add the gap surface area of each gap location for the primary seal and the secondary seal individually and divide the sum for each by the nominal diameter of the tank and compare each ratio to the respective standards in paragraphs (b) (4) of this section.

(4) Make necessary repairs or empty the storage vessel within 45 days of identification in any inspection for seals not meeting the requirements listed in (b) (4) (i) and (ii) of this section:

(i) The accumulated area of gaps between the tank wall and the mechanical shoe or liquid-mounted primary seal shall not exceed 10 in² per foot of tank diameter, and the width of any portion of any gap shall not exceed 1.5 in. There are to be no holes, tears, or other openings in the shoe, seal fabric, or seal envelope.

(ii) The secondary seal is to meet the following requirements:

(A) The secondary seal is to be installed above the primary seal so that it completely covers the space between the roof edge and the tank wall except as provided in paragraph (b) (2) (iii) of this section.

(B) The accumulated area of gaps between the tank wall and the secondary seal used in combination with a metallic shoe or liquid mounted primary seal shall not exceed 1.0 in² per foot of tank diameter, and the width of any portion of any gap shall not exceed 0.5 in. There shall be no gaps between the tank wall and the secondary seal when used in combination with a vapor mounted primary seal.

(C) There are to be no holes, tears, or other openings in the seal or seal fabric.

(iii) If a failure that is detected during inspections required in paragraph (b) (1) of §XX.113b(b) cannot be repaired within 45 days and if the vessel cannot be emptied within 45 days, a 30-day extension may be requested from the Agency in the inspection report required in §XX.115b(b) (4). Such extension request must include a demonstration of unavailability of alternate storage capacity and a specification of a schedule that will assure that the control equipment will be repaired or the vessel will be emptied as soon as possible.

(5) Notify the Agency 30 days in advance of any gap measurements required by paragraph (b) (1) of this section to afford the Agency the opportunity to have an observer present.

(6) Visually inspect the external floating roof, the primary seal, secondary seal, and fittings each time the vessel is emptied and degassed.

(i) If the external floating roof has defects, the primary seal has holes, tears, or other openings in the seal or the seal fabric, or the secondary seal has holes, tears, or other openings in the seal or the seal fabric, the owner or operator shall repair the items as necessary so that none of the conditions specified in this paragraph exist before filling or refilling the storage vessel with VOL.

(ii) For all the inspections required by paragraph (b) (6) of this section, the owner or operator shall notify the Agency in writing at least 30 days prior to the filling or refilling of each storage vessel to afford the Agency the opportunity to

inspect the storage vessel prior to refilling. If the inspection required by paragraph (b) (6) of this section is not planned and the owner or operator could not have known about the inspection 30 days in advance of refilling the tank, the owner or operator shall notify the Agency at least 7 days prior to the refilling of the storage vessel. Notification shall be made by telephone immediately followed by written documentation demonstrating why the inspection was unplanned. Alternatively, this notification including the written documentation may be made in writing and sent by express mail so that it is received by the Agency at least 7 days prior to the refilling.

(c) The owner or operator of each source that is equipped with a closed vent system and control device as required in §XX.112b (a) (4) or (b) (2) (other than a flare) shall meet the following requirements.

(1) Submit for approval by the Agency an operating plan containing the information listed below.

(i) Documentation demonstrating that the control device will achieve the required control efficiency during maximum loading conditions. This documentation is to include a description of the gas stream which enters the control device, including flow and VOC content under varying liquid level conditions (dynamic and static) and manufacturer's design specifications for the control device. If the control device or the closed vent capture system receives vapors, gases, or liquids other than fuels from sources that are not designated sources under this rule, the efficiency demonstration is to include consideration of all vapors, gases, and liquids received by the closed vent capture system and control device. If an enclosed combustion device with a minimum residence time of 0.75 seconds and a minimum temperature of 816 °C is used to meet the 95 percent requirements, documentation that those conditions will exist is sufficient to meet the requirements of this paragraph.

(ii) A description of the parameter or parameters to be monitored to ensure that the control device will be operated in

conformance with its design and an explanation of the criteria used for selection of that parameter (or parameters).

(2) Operate the closed vent system and control device and monitor the parameters of the closed vent system and control device in accordance with the operating plan submitted to the Agency in accordance with paragraph (c) (1) of this section, unless the plan was modified by the Agency during the review process. In this case, the modified plan applies.

(d) The owner or operator of each source that is equipped with a closed vent system and a flare to meet the requirements in §XX.112b (a) (4) or (b) (2) shall meet the requirements as specified in the general control device requirements, §60.18 (e) and (f).

§XX.114b Alternative means of emission limitation.

(a) If, in the Agency's judgment, an alternative means of emission limitation will achieve a reduction in emissions at least equivalent to the reduction in emissions achieved by any requirement in §XX.112b, the Agency will publish in the Federal Register a notice permitting the use of the alternative means for purposes of compliance with that requirement.

(b) Any notice under paragraph (a) of this section will be published only after notice and an opportunity for a hearing.

(c) Any person seeking permission under this section shall submit to the Agency a written application including:

(1) An actual emissions test that uses a full-sized or scale-model storage vessel that accurately collects and measures all VOC emissions from a given control device and that accurately simulates wind and accounts for other emission variables such as temperature and barometric pressure.

(2) An engineering evaluation that the Agency determines is an accurate method of determining equivalence.

(d) The Agency may condition the permission on requirements that may be necessary to ensure operation and maintenance to achieve the same emissions reduction as specified in §XX.112b.

§XX.115b Reporting and recordkeeping requirements.

The owner or operator of each storage vessel as specified in §XX.112b(a) shall keep records and furnish reports as required by paragraphs (a), (b), or (c) of this section depending upon the control equipment installed to meet the requirements of §XX.112b. The owner or operator shall keep copies of all reports and records required by this section, except for the records required by (c) (1), for at least 2 years. The record required by (c) (1) will be kept for the life of the control equipment.

(a) After installing control equipment in accordance with §XX.112b(a) (1) or (2) (fixed roof and internal floating roof), the owner or operator shall meet the following requirements.

(1) Furnish the Agency with a report that describes the control equipment and certifies that the control equipment meets the specifications of §XX.112b(a) (1) and §XX.113b(a) (1).

(2) Keep a record of each inspection performed as required by §XX.113b(a) (1), (a) (2), (a) (3), and (a) (4). Each record shall identify the storage vessel on which the inspection was performed and shall contain the date the vessel was inspected and the observed condition of each component of the control equipment (seals, internal floating roof, and fittings).

(3) If any of the conditions described in §XX.113b(a) (2) are detected during the annual visual inspection required by §XX.113b(a) (2), a report shall be furnished to the Agency within 30 days of the inspection. Each report shall identify the storage vessel, the nature of the defects, and the date the storage vessel was emptied or the nature of and date the repair was made.

(4) After each inspection required by §XX.113b(a) (3) that finds holes or tears in the seal or seal fabric, or defects in the internal floating roof, or other control equipment defects listed in §XX.113b(a) (3) (ii), a report shall be furnished to the Agency within 30 days of the inspection. The report shall identify the storage vessel and the reason it did not meet the

specifications of §61.112b(a) (1) or (2) or §XX.113b(a) and list each repair made.

(b) After installing control equipment in accordance with §61.112b(a) (3) (external floating roof), the owner or operator shall meet the following requirements.

(1) Furnish the Agency with a report that describes the control equipment and certifies that the control equipment meets the specifications of §XX.112b(a) (3) and §XX.113b(b) (2), (b) (3), and (b) (4).

(2) Within 60 days of performing the seal gap measurements required by §XX.113b(b) (1), furnish the Agency with a report that contains:

(i) The date of measurement.

(ii) The raw data obtained in the measurement.

(iii) The calculations described in §XX.113b (b) (2) and (b) (3).

(3) Keep a record of each gap measurement performed as required by §XX.113b(b). Each record shall identify the storage vessel in which the measurement was performed and shall contain:

(i) The date of measurement.

(ii) The raw data obtained in the measurement.

(iii) The calculations described in §XX.113b (b) (2) and (b) (3).

(4) After each seal gap measurement that detects gaps exceeding the limitations specified by §XX.113b(b) (4), submit a report to the Agency within 30 days of the inspection. The report will identify the vessel and contain the information specified in paragraph (b) (2) of this section and the date the vessel was emptied or the repairs made and date of repair.

(c) After installing control equipment in accordance with §XX.112b (a) (4) or (b) (1) (closed vent system and control device other than a flare), the owner or operator shall keep the following records.

(1) A copy of the operating plan.

(2) A record of the measured values of the parameters monitored in accordance with §XX.113b(c) (2).

(d) After installing a closed vent system and flare to comply with §XX.112b, the owner or operator shall meet the following requirements.

(1) A report containing the measurements required by §60.18(f)(1), (2), (3), (4), (5), and (6) shall be furnished to the Agency as required by §60.8 of the General Provisions. This report shall be submitted within 6 months of the initial start-up date.

(2) Records shall be kept of all periods of operation during which the flare pilot flame is absent.

(3) Semiannual reports of all periods recorded under §60.115b(b)(d)(2) in which the pilot flame was absent shall be furnished to the Agency.

§XX.116b Monitoring of operations.

(a) The owner or operator shall keep copies of all records required by this section, except for the record required by paragraph (b) of this section, for at least 2 years. The record required by paragraph (b) of this section will be kept for the life of the source.

(b) The owner or operator of each storage vessel as specified in §XX.110b(a) shall keep readily accessible records showing the dimension of the storage vessel and an analysis showing the capacity of the storage vessel. Each storage vessel with a design capacity less than [Volume cutoff] gal is subject to no provision of this rule other than those required by this paragraph.

(c) Except as provided in paragraphs (f) and (g) of this section, the owner or operator of each storage vessel either with a design capacity greater than or equal to [Volume cutoff] gal storing a liquid with a maximum true vapor pressure greater than or equal to [Vapor pressure cutoff 1] psia but less than [Vapor pressure cutoff 2] psia shall maintain a record of the VOL storage, the period of storage, and the maximum true vapor pressure of that VOL during the respective storage period.

(d) Except as provided in paragraph (g) of this section, the owner or operator of each storage vessel either with a design capacity greater than or equal to [Volume cutoff] gal storing a liquid with a maximum true vapor pressure that is normally less than [Vapor pressure cutoff 2] psia shall notify the Agency within 30 days when the maximum true vapor pressure of the liquid exceeds [Vapor pressure cutoff 2] psia.

(e) Available data on the storage temperature may be used to determine the maximum true vapor pressure as determined below.

(1) For vessels operated above or below ambient temperatures, the maximum true vapor pressure is calculated based upon the highest expected calendar-month average of the storage temperature. For vessels operated at ambient temperatures, the maximum true vapor pressure is calculated based upon the maximum local monthly average ambient temperature as reported by the National Weather Service.

(2) For local crude oil or refined petroleum products the vapor pressure may be obtained by the following:

(i) Available data on the Reid vapor pressure and the maximum expected storage temperature based on the highest expected calendar-month average temperature of the stored product may be used to determine the maximum true vapor pressure from nomographs contained in API Bulletin 2517 unless the Agency specifically requests that the liquid be sampled, the actual storage temperature determined, and the Reid vapor pressure determined from the sample(s).

(ii) The true vapor pressure of each type of crude oil with a Reid vapor pressure less than 2 psi or with physical properties that preclude determination by the recommended method is to be determined from available data and recorded if the estimated maximum true vapor pressure is greater than 0.5 psia.

(3) For other liquids, the vapor pressure:

(i) May be obtained from standard reference texts, or

(ii) Determined by ASTM Method D2879-83; or

(iii) Measured by an appropriate method approved by the Agency; or

(iv) Calculated by an appropriate method approved by the Agency.

(f) The owner or operator of each vessel storing a waste mixture of indeterminate or variable composition shall be subject to the following requirements.

(1) Prior to the initial filling of the vessel, the highest maximum true vapor pressure for the range of anticipated liquid compositions to be stored will be determined using the methods described in paragraph (e) of this section.

(2) For vessels in which the vapor pressure of the anticipated liquid composition is above the cutoff for monitoring but below the cutoff for controls as defined in §XX.112b(a), an initial physical test of the vapor pressure is required; and a physical test at least once every 6 months thereafter is required as determined by the following methods:

(i) ASTM Method D2879-83; or

(ii) ASTM Method D323-82; or

(iii) As measured by an appropriate method as approved by the Agency.

(g) The owner or operator of each vessel equipped with a closed vent system and control device meeting the specifications of §XX.112b is exempt from the requirements of paragraphs (c) and (d) of this section.



APPENDIX B
INCREMENTAL COST-EFFECTIVENESS TABLES

This appendix contains more detailed cost information than was presented in Chapter 6. Specifically, this appendix presents the incremental cost-effectiveness values between the different control options and within control options for the different tank types.

The columns labelled "cost-effectiveness" contain estimates of average cost-effectiveness values, i.e., costs per megagram of emission reductions to implement the particular control option at a specific vapor pressure "cutoff." These values were included in the tables in Chapter 6.

The columns labelled "incremental cost-effectiveness" contain estimates of costs per megagram of emission reductions to select a more stringent alternative. For example, in Table B-1 ("within option" table) for fixed roof tanks, it costs 24.2 million dollars per year to implement Control Option II for tanks at or above 0.75 psia, which results in emission reductions of 48,630 per year. It costs 17.9 million dollars per year to implement the same option for tanks at or above 1.0 psia, which results in emission reductions of 42,450 megagrams per year. The incremental cost-effectiveness is the cost per megagram of emission reductions to control the fixed roof tanks in the range of 0.75 psia to 1.0 psia, and is calculated as follows:

$$(\$24.2 \text{ million} - \$17.9 \text{ million}) / (48630 \text{ Mg} - 42450 \text{ Mg}) = \\ \$1,020/\text{Mg}$$

The incremental cost-effectiveness values given in the "between option" tables represent costs per megagram of emission reductions to implement a particular control option instead of

another. For example, in Table B-2 for fixed roof tanks, there is a credit of \$150 per megagram of emissions reduced for implementing Option II at 0.75 psia rather than implementing Option I at the same vapor pressure.

TABLE B-1. INCREMENTAL COST-EFFECTIVENESS WITHIN EACH CONTROL OPTION FOR FIXED-ROOF TANKS

Control options/ cutoff values	Nationwide capital costs, \$ (millions)	Nationwide annual cost, \$/yr (millions)	Nationwide emissions reduction, Mg/yr (tons/yr)	Cost-effectiveness, \$/Mg (\$/ton)	Incremental cost effectiveness, \$/Mg (\$/ton)
Control Option I^d					
VP = 0.5 ^a	280	30.7	51,960 (57,730)	590 (530)	1,600 (1,460)
VP = 0.75 ^b	222	24.3	47,950 (53,280)	510 (460)	1,070 (960)
VP = 1.0 ^c	163	17.9	41,970 (46,630)	430 (380)	-
Control Option II^e					
VP = 0.5 ^a	281	30.6	52,650 (58,500)	580 (520)	1,590 (1,450)
VP = 0.75 ^b	222	24.2	48,630 (54,030)	500 (450)	1,020 (920)
VP = 1.0 ^c	164	17.9	42,450 (47,170)	420 (380)	-
Control Option III^f					
VP = 0.5 ^a	295	34.4	52,780 (58,640)	650 (590)	1,750 (1,590)
VP = 0.75 ^b	234	27.2	48,670 (54,080)	560 (500)	1,170 (1,060)
VP = 1.0 ^c	172	20.0	42,540 (47,270)	470 (420)	-
Control Option IV^g					
VP = 0.5 ^a	513	91.4	53,690 (59,650)	1,700 (1,530)	4,520 (4,110)
VP = 0.75 ^b	406	72.3	49,460 (54,960)	1,460 (1,320)	3,020 (2,720)
VP = 1.0 ^c	299	53.3	43,170 (47,970)	1,230 (1,110)	-

^aBased on a vapor pressure cutoff value of 0.5 psia and a tank capacity cutoff value of 40,000 gallons.

^bBased on a vapor pressure cutoff value of 0.75 psia and a tank capacity cutoff value of 40,000 gallons.

^cBased on a vapor pressure cutoff value of 1.0 psia and a tank capacity cutoff value of 40,000 gallons.

^dControl Option I = installation of an aluminum noncontact IFR with vapor-mounted primary seals and uncontrolled fittings.

^eControl Option II = installation of an aluminum noncontact IFR with vapor-mounted primary seals, secondary seals, and controlled fittings.

^fControl Option III = installation of an aluminum noncontact IFR with liquid-mounted primary seals, secondary seals, and controlled fittings.

^gControl Option IV = installation of a welded steel contact IFR with liquid-mounted primary seals, secondary seals, and controlled fittings.

TABLE B-2. INCREMENTAL COST-EFFECTIVENESS BETWEEN EACH CONTROL OPTION FOR FIXED-ROOF TANKS

Control options/ cutoff values	Nationwide capital costs, \$ (millions)	Nationwide annual cost, \$/yr (millions)	Nationwide emissions reduction, Mg/yr (tons/yr)	Cost-effectiveness, \$/Mg (\$/ton)	Incremental cost effectiveness, \$/Mg (\$/ton)
Control Option I^d					
VP = 0.5 ^a	280	30.7	51,960 (57,730)	590 (530)	--
VP = 0.75 ^b	222	24.3	47,950 (53,280)	510 (460)	--
VP = 1.0 ^c	163	17.9	41,970 (46,630)	430 (380)	--
Control Option II^e					
VP = 0.5 ^a	281	30.6	52,650 (58,500)	580 (520)	-140 (-130)
VP = 0.75 ^b	222	24.2	48,630 (54,030)	500 (450)	-150 (-130)
VP = 1.0 ^c	164	17.9	42,450 (47,170)	420 (380)	0 (0)
Control Option III^f					
VP = 0.5 ^a	295	34.4	52,780 (58,640)	650 (590)	29,200 (26,570)
VP = 0.75 ^b	234	27.2	48,670 (54,080)	560 (500)	75,000 (68,250)
VP = 1.0 ^c	172	20.0	42,540 (47,270)	470 (420)	23,330 (21,200)
Control Option IV^g					
VP = 0.5 ^a	513	91.4	53,690 (59,650)	1,700 (1,530)	62,600 (56,970)
VP = 0.75 ^b	406	72.3	49,460 (54,960)	1,460 (1,320)	57,100 (51,960)
VP = 1.0 ^c	299	53.3	43,170 (47,970)	1,230 (1,110)	52,900 (48,140)

^aBased on a vapor pressure cutoff value of 0.5 psia and a tank capacity cutoff value of 40,000 gallons.

^bBased on a vapor pressure cutoff value of 0.75 psia and a tank capacity cutoff value of 40,000 gallons.

^cBased on a vapor pressure cutoff value of 1.0 psia and a tank capacity cutoff value of 40,000 gallons.

^dControl Option I = installation of an aluminum noncontact IFR with vapor-mounted primary seals and uncontrolled fittings.

^eControl Option II = installation of an aluminum noncontact IFR with vapor-mounted primary seals, secondary seals, and controlled fittings.

^fControl Option III = installation of an aluminum noncontact IFR with liquid-mounted primary seals, secondary seals, and controlled fittings.

^gControl Option IV = installation of a welded steel contact IFR with liquid-mounted primary seals, secondary seals, and controlled fittings.

TABLE B-3. INCREMENTAL COST-EFFECTIVENESS WITHIN EACH CONTROL OPTION FOR INTERNAL FLOATING ROOF TANKS

Control options/ cutoff values	Nationwide capital costs, \$ (millions)	Nationwide annual cost, \$/yr (millions)	Nationwide emissions reduction, Mg/yr (tons/yr)	Cost-effectiveness, \$/Mg (\$/ton)	Incremental cost effectiveness, \$/Mg (\$/ton)
Control Option I^a					
VP = 0.5 ^b	4.1	0.44	860 (950)	510 (470)	2,500 (2,280)
VP = 0.75 ^c	4.0	0.43	850 (940)	500 (460)	1,670 (1,520)
VP = 1.0 ^d	3.8	0.42	850 (940)	500 (460)	2,000 (1,820)
VP = 1.5 ^e	3.7	0.40	840 (920)	480 (440)	--
Control Option II^f					
VP = 0.5 ^b	42.9	8.8	4,750 (5,230)	1,850 (1,680)	13,300 (12,100)
VP = 0.75 ^c	41.6	8.4	4,720 (5,190)	1,780 (1,620)	6,670 (6,070)
VP = 1.0 ^d	40.4	8.2	4,690 (5,160)	1,750 (1,590)	5,000 (4,550)
VP = 1.5 ^e	38.9	7.9	4,630 (5,090)	1,710 (1,550)	--
Control Option III^g					
VP = 0.5 ^b	144.2	35	6,290 (6,920)	5,560 (5,060)	33,300 (30,300)
VP = 0.75 ^c	140.0	34	6,260 (6,890)	5,430 (4,930)	20,000 (18,200)
VP = 1.0 ^d	135.9	33	6,210 (6,830)	5,310 (4,830)	12,500 (11,380)
VP = 1.5 ^e	130.9	32	6,130 (6,740)	5,220 (4,750)	--
Control Option IV^h					
VP = 0.5 ^b	876.5	226	11,870 (13,060)	19,040 (17,300)	116,670 (106,170)
VP = 0.75 ^c	851.3	219	11,810 (12,990)	18,540 (16,860)	66,670 (60,670)
VP = 1.0 ^d	826.2	213	11,720 (12,890)	18,170 (16,520)	53,330 (48,480)
VP = 1.5 ^e	795.6	205	11,570 (12,730)	17,720 (16,100)	--

^aControl Option I = control fittings.

^bBased on a vapor pressure cutoff value of 0.5 psia and a tank capacity cutoff value of 40,000 gallons and greater.

^cBased on a vapor pressure cutoff value of 0.75 psia and a tank capacity cutoff value of 40,000 gallons and greater.

^dBased on a vapor pressure cutoff value of 1.0 psia and a tank capacity cutoff value of 40,000 gallons and greater.

^eBased on a vapor pressure cutoff value of 1.5 psia and a tank capacity cutoff value of 40,000 gallons and greater.

^fControl Option II = control fittings and add a secondary seal.

^gControl Option III = replace vapor-mounted primary seal with liquid-mounted primary seal, secondary seals, and controlled fittings.

^hControl Option IV = replace noncontact IFR with a welded steel contact IFR with liquid-mounted primary seals, secondary seals, and controlled fittings.

TABLE B-4. INCREMENTAL COST-EFFECTIVENESS BETWEEN EACH CONTROL OPTION FOR INTERNAL FLOATING ROOF TANKS

Control options/ cutoff values	Nationwide capital costs, \$ (millions)	Nationwide annual cost, \$/yr (millions)	Nationwide emissions reduction, Mg/yr (tons/yr)	Cost-effectiveness, \$/Mg (\$/ton)	Incremental cost effectiveness, \$/Mg (\$/ton)
Control Option I^a					
VP = 0.5 ^b	4.1	0.44	860 (950)	510 (470)	---
VP = 0.75 ^c	4.0	0.43	850 (940)	500 (460)	---
VP = 1.0 ^d	3.8	0.42	850 (940)	500 (460)	---
VP = 1.5 ^e	3.7	0.40	840 (920)	480 (440)	---
Control Option II^f					
VP = 0.5 ^b	42.9	8.8	4,750 (5,230)	1,850 (1,680)	2,140 (1,940)
VP = 0.75 ^c	41.6	8.4	4,720 (5,190)	1,780 (1,620)	2,070 (1,880)
VP = 1.0 ^d	40.4	8.2	4,690 (5,160)	1,750 (1,590)	2,030 (1,850)
VP = 1.5 ^e	38.9	7.9	4,630 (5,090)	1,710 (1,550)	1,980 (1,800)
Control Option III^g					
VP = 0.5 ^b	144.2	35	6,290 (6,920)	5,560 (5,060)	17,010 (15,480)
VP = 0.75 ^c	140.0	34	6,260 (6,890)	5,430 (4,930)	16,620 (15,120)
VP = 1.0 ^d	135.9	33	6,210 (6,830)	5,310 (4,830)	16,320 (14,850)
VP = 1.5 ^e	130.9	32	6,130 (6,740)	5,220 (4,750)	16,070 (14,620)
Control Option IV^h					
VP = 0.5 ^b	876.5	226	11,870 (13,060)	19,040 (17,300)	34,230 (31,150)
VP = 0.75 ^c	851.3	219	11,810 (12,990)	18,540 (16,860)	33,330 (30,330)
VP = 1.0 ^d	826.2	213	11,720 (12,890)	18,170 (16,520)	32,670 (29,730)
VP = 1.5 ^e	795.6	205	11,570 (12,730)	17,720 (16,100)	31,800 (28,940)

^aControl Option I = control fittings.

^bBased on a vapor pressure cutoff value of 0.5 psia and a tank capacity cutoff value of 40,000 gallons and greater.

^cBased on a vapor pressure cutoff value of 0.75 psia and a tank capacity cutoff value of 40,000 gallons and greater.

^dBased on a vapor pressure cutoff value of 1.0 psia and a tank capacity cutoff value of 40,000 gallons and greater.

^eBased on a vapor pressure cutoff value of 1.5 psia and a tank capacity cutoff value of 40,000 gallons and greater.

^fControl Option II = control fittings and add a secondary seal.

^gControl Option III = replace vapor-mounted primary seal with liquid-mounted primary seal, secondary seals, and controlled fittings.

^hControl Option IV = replace noncontact IFR with a welded steel contact IFR with liquid-mounted primary seals, secondary seals, and controlled fittings.

TABLE B-5. INCREMENTAL COST-EFFECTIVENESS WITHIN EACH CONTROL OPTION FOR EXTERNAL FLOATING ROOF TANKS

Control options/ cutoff values	Nationwide capital costs, \$ (millions)	Nationwide annual cost, \$/yr (millions)	Nationwide emissions reduction, Mg/yr (tons/yr)	Cost effectiveness, \$/Mg (\$/ton)	Incremental cost effectiveness, \$/Mg (\$/ton)
Mechanical shoe primary seals ^a					
<u>Control Option I</u> ^b					
VP = 0.5 ^c	13.4	-1.0	11,050 (12,160)	-90 (-80)	2,140 (1,950)
VP = 0.75 ^d	11.7	-1.3	10,910 (12,000)	-120 (-110)	2,000 (1,820)
VP = 1.0 ^e	10.0	-1.7	10,710 (11,780)	-160 (-140)	1,330 (1,210)
VP = 1.5 ^f	4.8	-2.8	9,880 (10,870)	-280 (-260)	-

^aFor base case of external floating roof with mechanical shoe primary seals. Assumes all EFR tanks are equipped with mechanical shoe primary seals.

^bOption I = Control fittings and add a secondary seal.

^cBased on a vapor pressure cutoff value of 0.5 psia and a tank capacity cutoff value of 40,000 gallons.

^dBased on a vapor pressure cutoff value of 0.75 psia and a tank capacity cutoff value of 40,000 gallons.

^eBased on a vapor pressure cutoff value of 1.0 psia and a tank capacity cutoff value of 40,000 gallons.

^fBased on a vapor pressure cutoff value of 1.5 psia and a tank capacity cutoff value of 40,000 gallons.²