

# Pipeline

nesc

Fall 2002  
Vol. 13, No. 4



Small Community Wastewater Issues Explained to the Public

## Alternative Dispersal Options

**O**vercoming the challenges of providing an onsite sewage system on a not-quite-perfect building site takes some thought, but by careful analysis of the site characteristics and constraints, a number of alternative systems are possible choices for the homeowner.

The choices are also narrowed down by each individual states' regulations and by the prohibitive costs of some alternative systems. But as prime building sites become scarce, wise engineers and designers keep current on treatment technologies for wastewater where site conditions are not ideal.

Certain site conditions or constraints influence the type of onsite system considered for the lot. The four most influential are: slope, vertical separation distances, soil characteristics and permeability (the ability of water to move through spaces in the soil). Horizontal separation distances from property lines, bodies of water, buildings, etc., also need to be met. Each state's minimum site requirements for installation of a conventional septic system are different and may vary from the criteria listed above.

These tight site parameters become less restrictive when the designer and homeowner consider a wider range of dispersal technologies. Once wastewater undergoes primary treatment in the septic tank, the clarified effluent flows to the dispersal area (drainfield) for final treatment and dispersal. Since the site characteris-

tics limit the method of dispersal more than other components, the dispersal component should be selected first, followed by selection of pretreatment and advanced wastewater components.

Where site conditions are suitable, subsurface soil absorption is usually the best method of wastewater dispersal for single dwellings. It is simple, stable and low cost. Under the proper conditions, the soil is an excellent treatment medium and requires little wastewater pretreatment. Partially treated wastewater is discharged below the ground surface where it is absorbed and treated by the soil as it percolates to the groundwater.

Several different designs of subsurface soil absorption systems may be used. They include pressure systems, contour systems, drip irrigation, chambers, gravelless systems, mound/at grade, and evapotranspiration. The design

selected depends on the site characteristics encountered. Critical site factors include soil profile characteristics and permeability, soil depth over water tables or bedrock, slope, and size of the area.

This issue of *Pipeline* presents descriptions and technical drawings of various dispersal designs and technologies that can be used to overcome site limitations for onsite wastewater treatment.

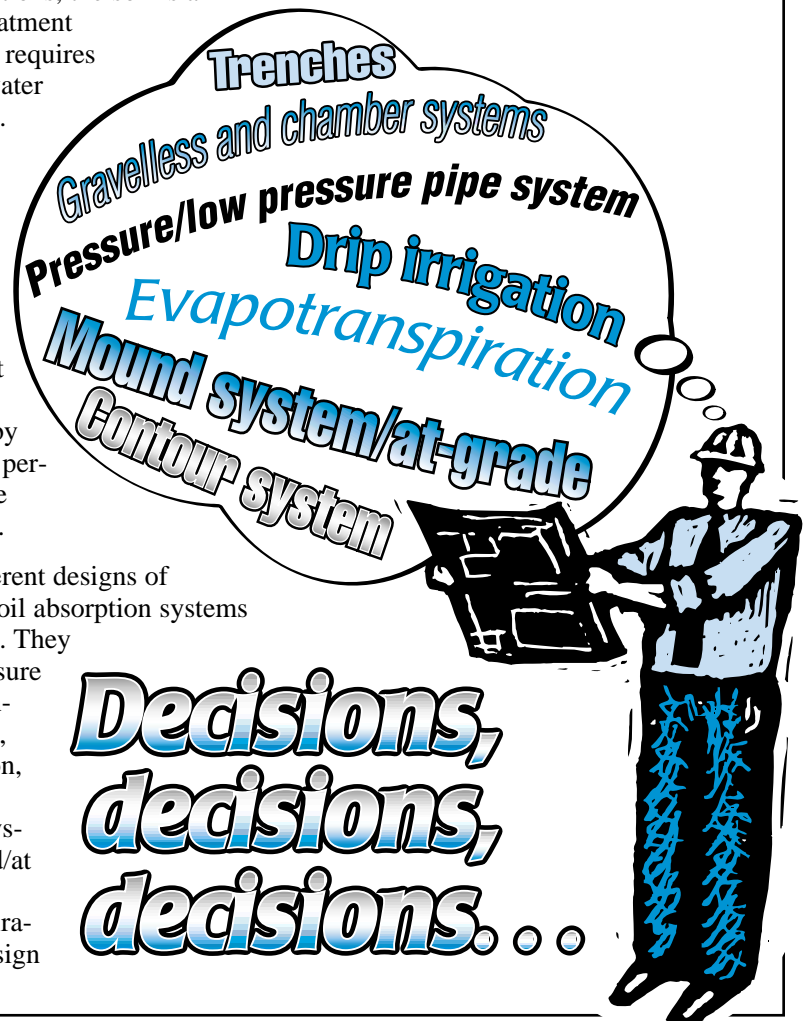

# Trenches

The most commonly used system, the conventional septic system, consists of two main parts: a septic tank and a soil absorption system. The septic tank is a watertight tank that holds the wastewater discharged from the house for 24 to 48 hours, allowing sludge and scum to separate from the wastewater. Effluent passes (usually by gravity flow) from the septic tank to the soil absorption system, which can be either a bed or trenches.

The effluent is treated in both the soil absorption system and the surrounding soil. Septic systems generally require minimal routine maintenance, are relatively inexpensive to install, and if properly designed and constructed, are reliable for a relatively long period of time.

For beds or trenches the following general criteria usually apply:

- Slope—0 to 25 percent (0 to 5 percent for beds)
- Vertical separation distances—2 to 4 feet of unsaturated soil between the bottom of the system and the seasonally high water table or bedrock
- Soil—sandy or loamy textures are best with bright, uniform colors
- Percolation rate—between 1 and 60 min/in (based on an average of at least three perc tests).

The trench system consists of shallow, level excavations, usually 1 to 5 feet deep and 1 to 3 feet wide. The excavated area is usually filled with 6 inches or more of porous medium, such as gravel. Next, a distribution network is laid out over the media. A single line of perforated distribution pipe is laid in each trench. A semi-permeable barrier such as building paper or straw

is placed on top of the network before the system is covered with soil. The wastewater trickles through the network, through the media, and into the soil. Treatment of the wastewater occurs in both the media and soil sections of the trench system.

Bed systems consist of an excavated area, normally wider than 3 feet and 1 to 5 feet deep. The excavated bed is filled with gravel, the distribution pipe laid in and covered with an impermeable layer like the trench system before being buried with topsoil.

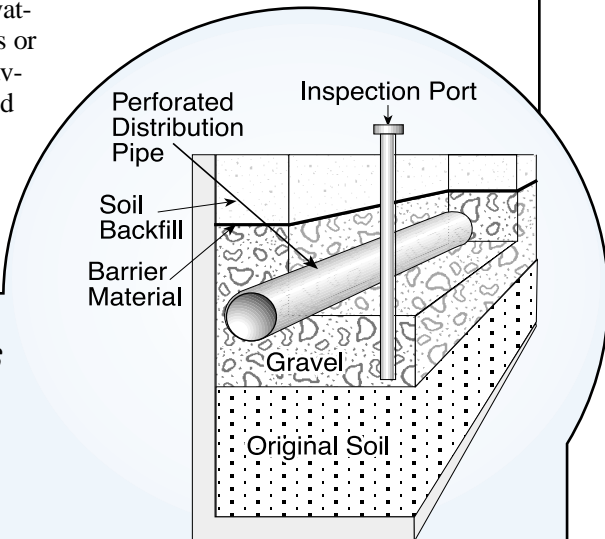

## Trenches

### Geometry, orientation, and configuration considerations for Subsurface Wastewater Infiltration Systems

**Design type**      **Design considerations**

#### Trench

**Geometry**

- Width**      Preferably less than 3 feet. Design width is affected by distribution method, constructability, and available area.
- Length**      Restricted by available length parallel to site contour, distribution method, and distribution network design.
- Sidewall height**      Sidewalls are not considered an active infiltration surface. Minimum height is that needed to encase the distribution piping or to meet peak flow storage requirements.

**Orientation/configuration**      Should be constructed parallel to site contours and/or water table or restrictive layer contours. Should not exceed the site's maximum linear hydraulic loading rate per unit of length. Spacing of multiple, parallel trenches is also limited by the construction method and slow dispersion from the trenches.

#### Bed

**Geometry**

- Width**      Should be as narrow as possible. Beds wider than 10 to 15 feet should be avoided.
- Length**      Restricted by available length parallel to site contour, distribution method, and distribution network design.
- Sidewall height**      Sidewalls are not considered an active infiltration surface. Minimum height is that needed to encase the distribution piping or to meet peak flow storage requirements.

**Orientation/configuration**      Should be constructed parallel to site contours and/or water table or restrictive layer contours. The loading over the total projected width should not exceed the estimated downslope maximum linear hydraulic loading.

Taken from Table 4-4, USEPA Onsite Wastewater Treatment Systems Manual, 2002

# Contour system

In this gravity-fed system, a connecting line leads to several feet of perforated distribution pipe set in one shallow trench that follows the contour of the land. Sand and gravel, together with a geotextile covering, are placed in the trench. This system provides a large area for effluent dispersal into the soil. As with any soil absorption system placed on slightly sloping land, an interceptor ditch may be placed up slope

from the dispersal trench to help divert surface runoff away from the trench.

The use of a contour system is advantageous because the effluent is spread over a much broader front, but there may be distinct

disadvantages also. In situations where trenches have to be over 150 feet long, the system must be pressurized. Depending on the underlying geology of the site, ensuring the levelness of the bottom of the trench can be difficult.

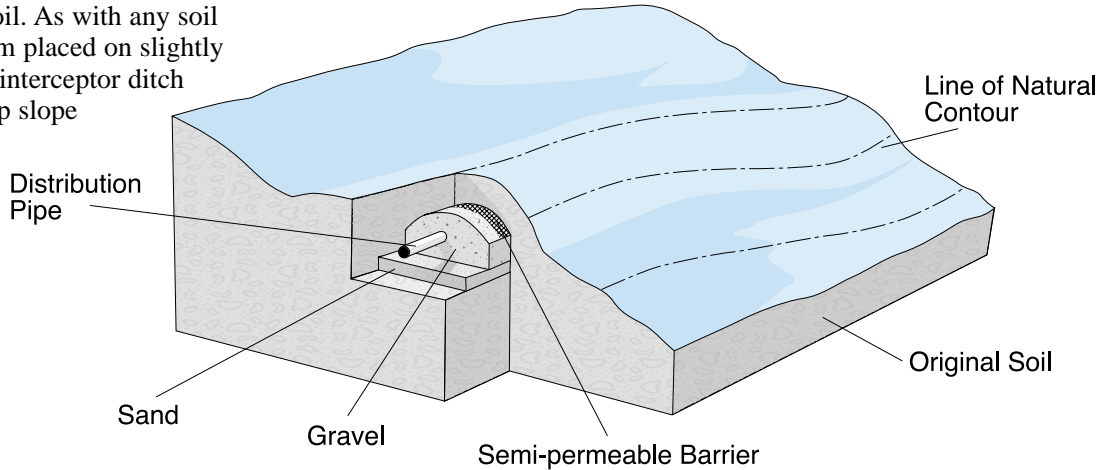

# Drip irrigation

Drip irrigation systems (also known as “trickle” systems) apply treated wastewater to soil slowly and uniformly through a network of thin, flexible tubing placed at shallow depths in the soil. Wastewater is pumped through the tubes and drips slowly from a series of openings

directly to plant roots. The automated Central Unit controls the system.

To protect public health and to prevent the system from clogging, the wastewater must be pretreated and filtered. One advantage of drip irrigation is minimal site disturbance due to the flexible tubing that can be placed around trees and shrubs.

Because irrigation systems are designed to apply wastewater at very shallow depths, irrigation may be permitted on certain sites with high bedrock, high groundwater, or slowly permeable soils. Drip systems can be designed to accommodate sites with complex terrain due to the flexible tubing used. While subsurface drip systems distribute water evenly and create fewer problems with odors and ponding, emitters have been found to clog, effecting the uniformity of application. The subsurface positioning makes it difficult to monitor and correct clogging.

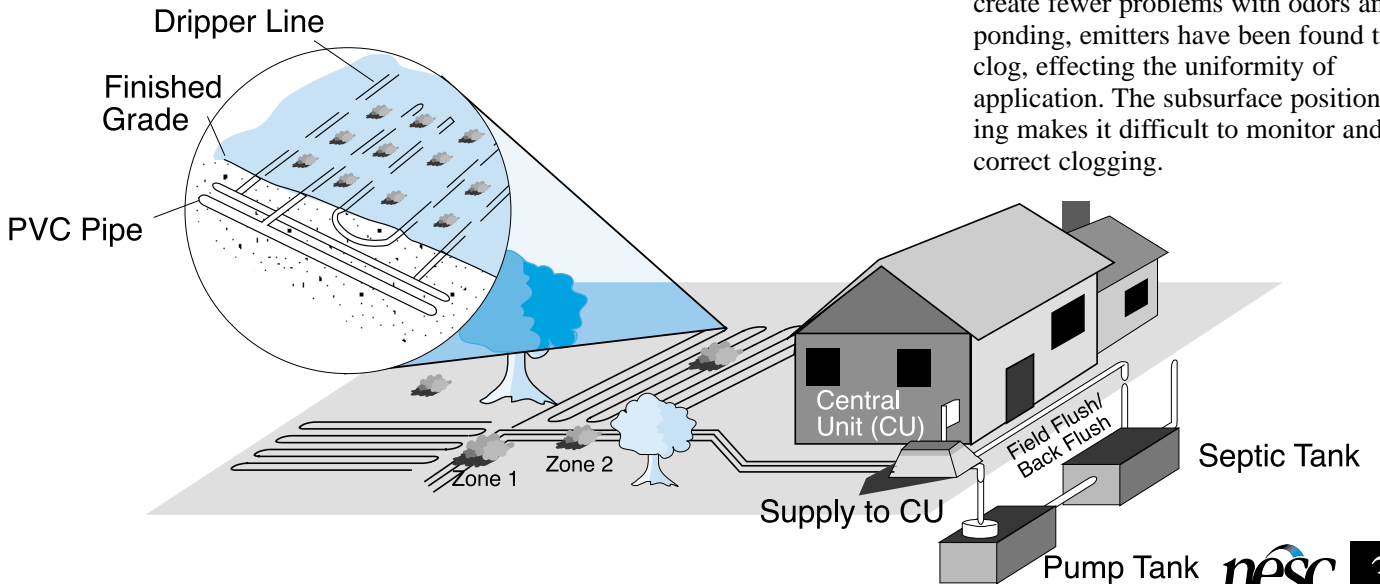

## Gravelless and chamber systems

Gravelless and chamber systems use some material other than gravel or rock in the excavation to provide an infiltrate surface onto which septic tank effluent is distributed along the length of the trench. These systems provide some capacity to store effluent until it can be absorbed into the soil and also to inhibit sand and silt infiltration.

Advantages of gravelless and chamber systems include faster installation and increased volume of void space per unit length compared to conventional stone trenches. Soil compaction is reduced since the need to use heavy equipment to haul and place gravel is eliminated. In some

instances, the area required for soil absorption is reduced for chamber/gravelless systems when compared to the area needed for conventional soil absorption systems. Homeowners are advised to check local codes to see if such a reduction is allowed.

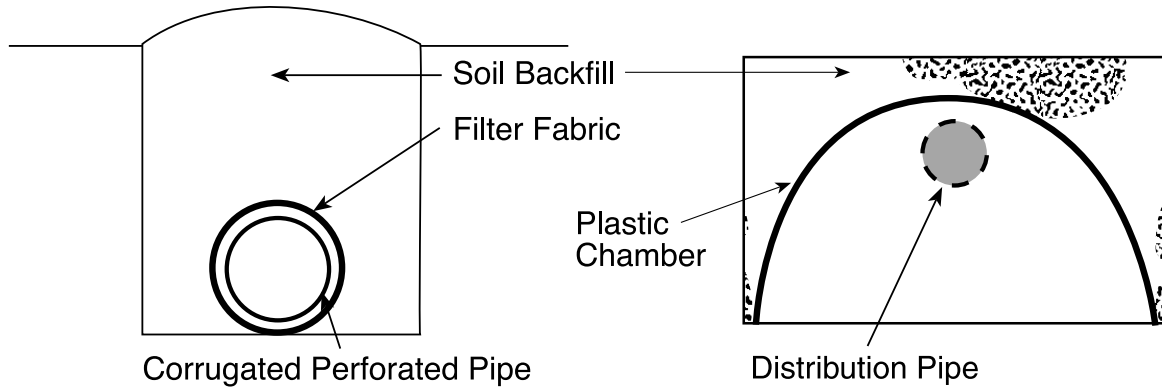

## Mound system/at-grade

The mound is simply a raised drain-field. A mound is composed of sand-fill on top of a gravel-filled bed and a network of small-diameter pipes known as the distribution system. Wastewater is pretreated in a septic tank, and then fed by gravity to a pump chamber where the effluent is dosed to the mound. In an at-grade system, the ground surface is the bottom of the trench. Construction consists of scraping the ground surface to expose the existing soil and

eliminating vegetation prior to adding gravel to the ground surface.

The mound design overcomes site restrictions such as slowly permeable soil, shallow permeable soils over creviced or porous bedrock, and permeable soils with high water tables.

Mounds may be constructed on sites with slopes of up to 25 percent, but not in flood plains, drainage ways, or

depressions unless flood protection is provided. Another siting consideration is adequate horizontal separation distances from water wells, surface waters, property boundaries, and building foundations. Although mound systems are typically much more expensive to install than conventional systems, when properly designed, constructed, and maintained, they are very satisfactory.

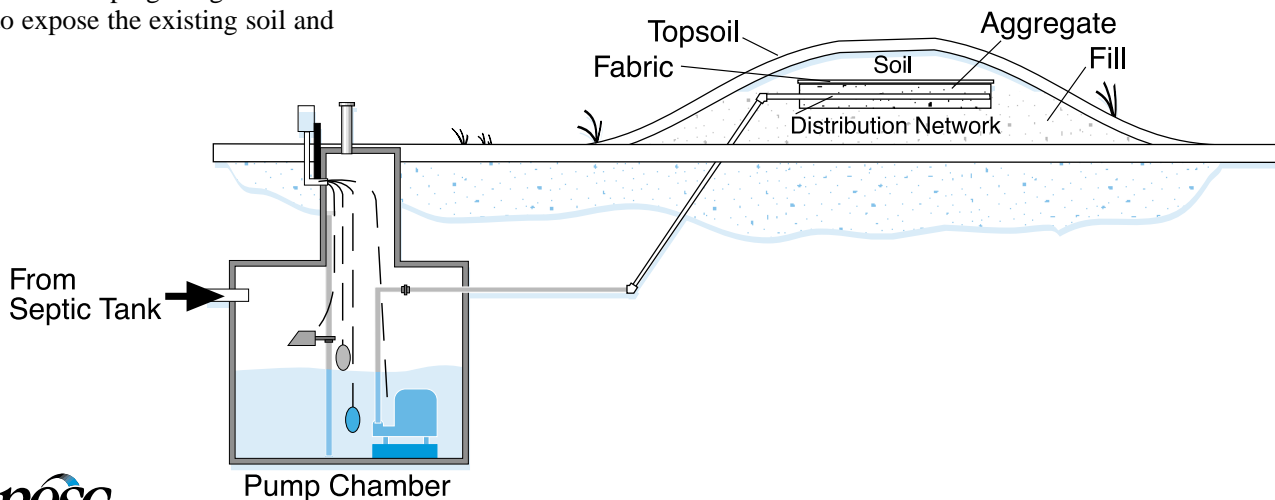

# Evapotranspiration

Evapotranspiration systems (ET) employ the combined effects of evaporation from soil and transpiration from plants to dispose of wastewater effluent. The effluent flows from the pretreatment unit to a sand bed underlaid with an impermeable liner. Vegetation above the sand bed wicks up the moisture through their roots, eventually transpiring the excess through their leaves. Moisture that migrates to the soil surface evaporates into the atmosphere. The evapotranspiration-absorption (ETA)

systems are similar but are designed for fairly impenetrable soils. ETA systems use unlined sand beds, allowing effluent to trickle slowly into the underlying ground.

ET systems can be used on sites having very porous soils and may be used to allow for a closer proximity to water wells (50 feet) as opposed to the one hundred-foot setback needed for soil absorption drain-fields. ET systems are most effective in locations having low rainfall

amounts, low humidity, high daily average temperatures, and high levels of solar radiation. Evapotranspiration must exceed rainfall by at least 24 inches or the system may become overloaded.

Due to the rather simple configuration, ETs require very little maintenance and are comparable in cost to other alternative onsite systems. ET systems are very useful in arid regions or on sites having very porous or impermeable soils.

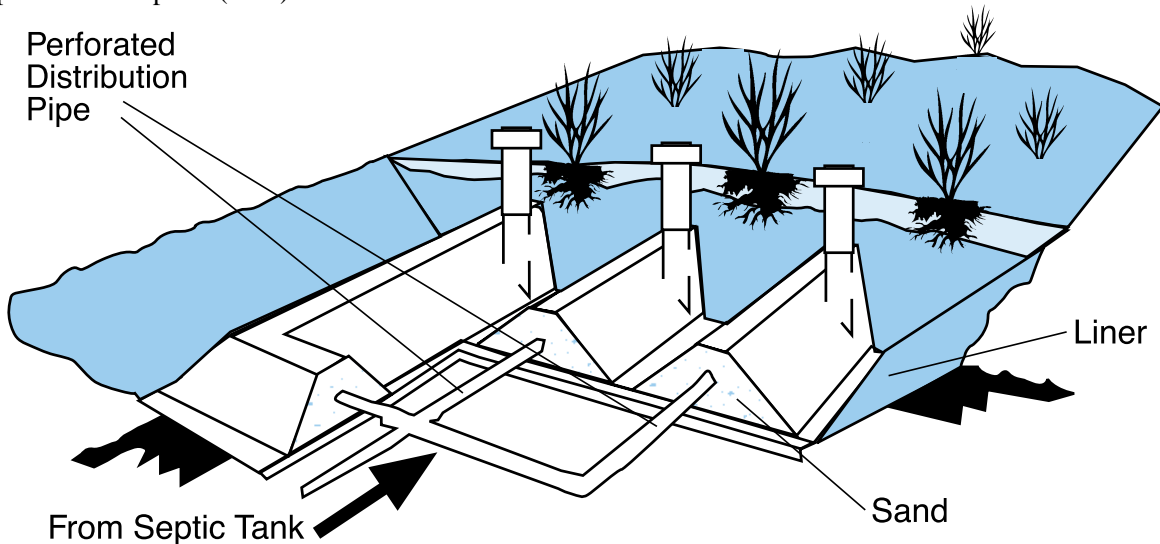

# Pressure/low pressure pipe system

Pressure and low-pressure pipe (LPP) systems are shallow, dosed soil absorption systems. LLP systems are composed of a septic tank or aerobic unit, a dosing chamber, and small-diameter distribution piping with small perforations. Partially clarified effluent is forced through the pipes at specific pumping sequences of one to two times daily, allowing breaks between doses for

the soil to absorb the wastewater. Dosing frequencies vary between sites and soil conditions.

These pressure pipe systems are especially designed to overcome the site constraints of anaerobic conditions due to continuous saturation and/or a high water table. LPP systems can be

located on sloping ground or on uneven terrain and can even be placed upslope of the home site, although in some cases, the suitability of these absorption designs can be limited by soil, slope, and space characteristics of a location.

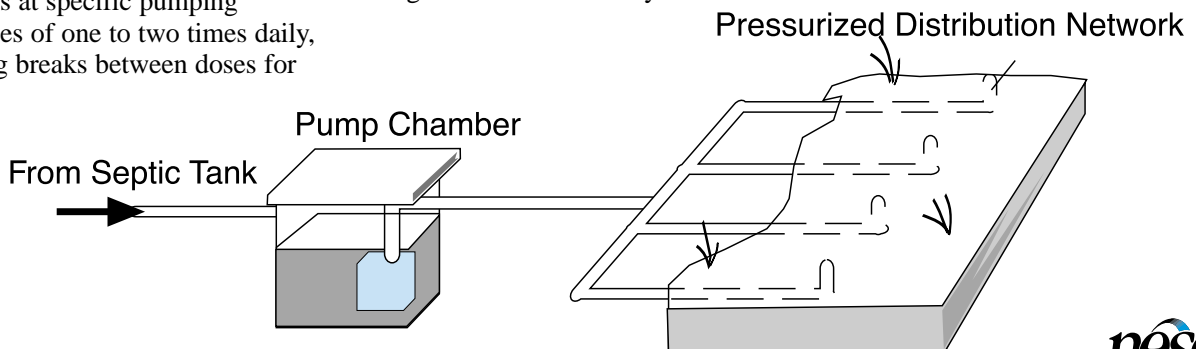

# Decisions, decisions, decisions. . . the process for determining the most appropriate technology

The Lick Observatory in California has been in use for more than 100 years and has provided more astronomical discoveries than any other in the world, but the antiquated wastewater treatment and dispersal systems in place are not up to the task of adequately treating the wastewater generated by over 40,000 visitors each year.

To address the worsening problem, the Kennedy/Jenks Consultants of San Francisco were contacted to recommend some innovative onsite replacement systems. Homeowners and local health officials may find it useful to follow the consultants' process as they determined the most appropriate onsite system for the observatory site.

## Up near the stars

Located in Northern California, where soils are typically shallow, the observatory site was especially difficult for the more commonly employed drainfields, but discharge of 'any degree of wastewater effluent to continuous or ephemeral watercourses is prohibited' by state law, so land disposal was the only option.

The Lick Observatory structures, including the observatory itself and a picnic area, are located on the spine of Mount Hamilton; the sides of the mountain slope away steeply in both directions. The exposed rock is only one meter below grade. The underlying rock is decomposed, fractured sandstone and shale. Of special concern is the fact that the existing septic tanks and leach fields are in the watersheds of the springs that are the observatory's only water supply.

Existing tanks were either too small or inaccessible (several had never been pumped or inspected); leach fields were too short to meet regulatory requirements and were of insufficient depth or located in fill soils. The slopes were very steep in most leach field locations, exceeding 20 percent.

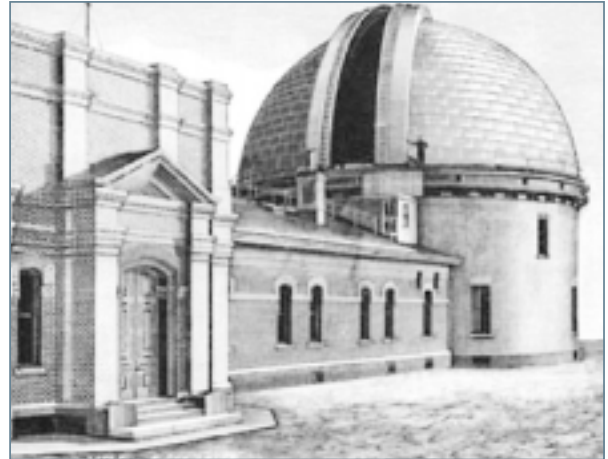

*The observatory, founded in 1888, has always been a part of the University of California. After more than a century of operation, Lick Observatory remains among the most productive research observatories in the world.*

## Determining regulatory authority

To begin the process, it is always necessary to know who provides local regulatory responsibility at the site. And for most homeowners, it is usually the local health department but this site crossed several jurisdictional boundaries. In the State of California, all wastewater disposal is regulated by the State Water Quality Control Board through regional water quality control boards and in this case, it would be the San Francisco Bay Region Water Quality Control Board. Specialists with the Santa Clara Health department were also involved for approval.

To determine percolation rates and soil conditions according to the Santa Clara Sewage Ordinance, it was decided to seek sites for wastewater dispersal that would conform to the minimum slope requirement of 20 percent and be accessible. Several sites were found that had soil with acceptable percolation rates and provided enough area for subsurface dispersal of all the wastewater.



*This view of Lick Observatory illustrates the steep hillsides and shallow soils of Mount Hamilton.*

## The recommendations

Three alternative systems were suggested.

### Alternative 1 – Individual septic tank and leach fields

The first alternative plan was to continue the use of individual tanks, and not provide secondary treatment or disinfection. Instead, water conservation fixtures would be utilized to reduce leach fields requirements by 25 percent. A layer of sand in the trench below the perforated pipe would provide a filter and a dosing siphon leachfield flow would provide uniform but intermittent flow and resting cycles. Single field replacements were proposed with a replacement field area designated nearby.

### Alternative 2 – Grouped wastewater treatment and disposal

This option would have individual septic tanks at each building that would either be pumped, or flow by gravity, to a recirculating sand filter. The wastewater would receive aerobic treatment in the sand filter followed by disinfection in a baffled tank system with a tablet chlorinator. A recirculating sand filter was selected over other possible systems because of its more compact size and less complexity. This system also has the lowest overall cost for construction, operation and maintenance.

## Reprint Info

Readers are encouraged to reprint *Pipeline* articles in local newspapers or include them in flyers, newsletters, or educational presentations. Please include the name and phone of the National Small Flows Clearinghouse (NSFC) on the reprinted information and send us a copy for our files. If you have any questions about reprinting articles or about any of the topics discussed in this newsletter, please contact the NSFC at 1-800-624-8301.

Table 1

### Comparison of cost and non-cost factors of septic system alternatives at Lick Observatory

Item type	Weighting factor	Alternatives		
		1	2	3
		Individual	Grouped	Community
Capital cost	25	20	15	12
O&M cost	25	25	10	5
Reliability	10	6	8	5
Flexibility	10	10	8	7
Expandability	10	8	7	9
Environmental	10	2	5	9
Aesthetic	10	10	5	8
Total	100	81	58	55
<b>RANK</b>		<b>1</b>	<b>2</b>	<b>3</b>

The percolation trench sizes were based on the tested percolation capacity and a sustained percolation rate of double the leach field area required by the county.

### Alternative 3 – Community wastewater treatment and disposal

This alternative would collect all the wastewater from the existing buildings by submersible grinder pumps. Using a combination of pressure pipes and a gravity system, all of the wastewater would be conveyed to a community treatment and dispersal site. Existing septic tanks would be maintained for overflow in the event of power outage or for short-term discharges.

### Making the right choice

The selection of the most appropriate replacement system must involve not only the capital costs plus operation and maintenance, but also other non-cost factors, such as reliability, flexibility, expandability, environmental and aesthetics.

Treatment reliability is defined as the dependability of the system to produce high-quality effluent on a continuing basis at the rated capacity. Flexibility is the ability to respond to changes in flow to accommodate flow pattern changes.

The expandability factor expresses how easily the system could be modified to handle an increase in capacity. Environmental factors include visual impact, noise, odor, and the potential for sludge production.

From a purely dollar standpoint, Alternative 1 rated as the most economical choice but the consultants didn't stop at that. They went on to assign values to the above non-cost factors for comparative purposes. Table 1 illustrates how the systems rated and were compared. Even with all these factors considered, Alternative 1, with the individual septic tanks and leach fields in combination with the water conservation fixtures, appeared to be the optimal choice for this situation.

This case study demonstrates some of the different steps required to choose which system is best for a given site.

*Editor's Note:* A copy of the original report on this project, *Innovative Replacements of Failed Septic Tank Leach Field Systems for Small Communities*, Robert A. Ryder, P.E., is available from NSFC. Request Item #L005630 at a cost of fifteen cents per page plus shipping.

# NSFC RESOURCES AVAILABLE

To order any of the following products, call the National Small Flows Clearinghouse (NSFC) at (800)624-8301 or (304)293-4191, fax (304)293-3161, e-mail

*nafc\_orders@nesc.wvu.edu*, or write NSFC, West Virginia University, PO Box 6064, Morgantown, WV 26506-6064. Be sure to request each item by number and title. A shipping and handling charge will apply.

## Onsite Wastewater Treatment for Small Communities and Rural Areas

The NSFC poster provides descriptions and illustrations of various onsite, conventional, and alternative wastewater treatment and disposal technologies. Formerly known as "Small Wastewater Systems: Alternative Systems for Small Communities and Rural Areas," the poster was revised to include several new technologies and to focus strictly on onsite technologies as opposed to both onsite and community-sized systems. The poster provides a large,

illustration depicting typical uses of alternative wastewater systems in a rural community setting and showing how some onsite technologies can be clustered. Item #WWPSPE02.

Cost is \$1.25 plus shipping.

## Wastewater Collection and Treatment Systems for Small Communities

This NSFC poster provides descriptions and illustrations of various onsite, conventional, and alternative wastewater treatment and disposal technologies. Although not meant to be a comprehensive guide to conventional and alternative small community and cluster systems, it serves to acquaint the public with several representative systems. Pretreatment options, including bar screens, comminutors/grinders and grit chambers, and secondary treatment options such as lagoons and ponds, activated sludge, and oxidation ditches, are only a few of the technologies presented. Item #WWPSPE65.

Cost is \$1.25 plus shipping.

## PIPELINE



*Pipeline* is published quarterly by the National Small Flows Clearinghouse at West Virginia University, P.O. Box 6064, Morgantown, WV 26506-6064

*Pipeline* is funded through a grant from the U.S. Environmental Protection Agency Washington, D.C.

Steve Hogye—*Project Officer*  
Municipal Support Division  
Office of Wastewater Management

National Small Flows Clearinghouse  
West Virginia University  
Morgantown, WV

Peter Casey — *Program Coordinator*  
Marilyn Noah — *Editor*

Jennifer Hause — *Technical Advisor*  
Chris Metzgar — *Graphic Designer*

Permission to quote from or reproduce articles in this publication is granted when due acknowledgement is given. Please send a copy of the publication in which information was used to the *Pipeline* editor at the address above.



an equal opportunity/affirmative action institution

ISSN 1060-0043

The contents of this newsletter do not necessarily reflect the views and policies of the U.S. Environmental Protection Agency, nor does the mention of trade names or commercial products constitute endorsement or recommendation for use.



Printed on recycled paper

For wastewater information, call the NSFC at (800) 624-8301 or (304) 293-4191

NONPROFIT  
ORGANIZATION  
U.S. POSTAGE PAID  
PERMIT NO. 34  
MORGANTOWN, WV

National Small Flows Clearinghouse  
WVU Research Corporation  
West Virginia University  
P.O. Box 6064  
Morgantown, WV 26505-6064  
ADDRESS SERVICE REQUESTED

