

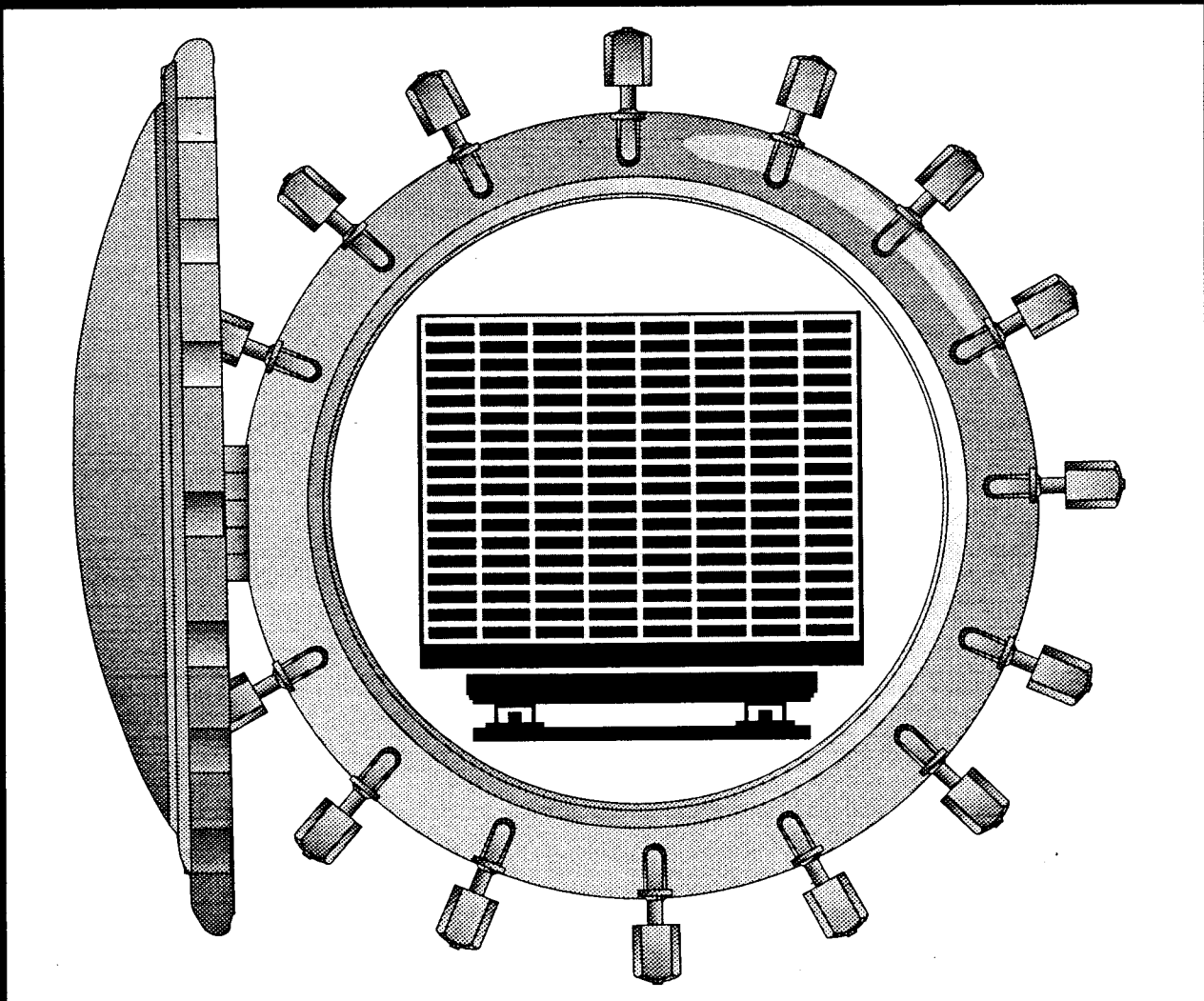
BU-6413-S  
Reviewed 1995

MINNESOTA EXTENSION SERVICE

UNIVERSITY OF MINNESOTA  
COLLEGE OF  
NATURAL RESOURCES

# THE PRESERVATION of WOOD

A Self Study Manual for Wood Treaters





---

MINNESOTA EXTENSION SERVICE

UNIVERSITY OF MINNESOTA  
COLLEGE OF  
NATURAL RESOURCES

# The Preservation of Wood

A Self Study Manual for Wood Treaters

Revised by  
F. Thomas Milton  
Extension Specialist and Associate Professor  
Department of Forest Products  
College of Natural Resources  
University of Minnesota

*This manual is a major revision of The Preservation of Wood, authored by Ian Stalker and Milton Applefield and coordinated by Burton R. Evans. This revised manual has been developed with the permission of the Cooperative Extension Service, University of Georgia, Athens, GA, publishers of the original (1986) manual.*



---

# Acknowledgements

This training manual draws upon the expertise of many individuals and compiles information from a number of sources.

The foundation of this manual is *The Preservation of Wood* published by the Cooperative Extension Service, University of Georgia. The state of Minnesota (like many other states) has used this publication for its pesticide applicator training programs since it became necessary (in 1986) to certify wood treaters handling creosote, penta and inorganic arsenical preservatives. Burton Evans, extension entomologist at the University of Georgia, has graciously allowed us to modify and revise their original manual. Use of the University of Georgia manual is gratefully appreciated.

Although the overall outline and content of our new manual resembles the original manual, there are some notable differences.

- A number of illustrations have been added and/or redrawn.
- New material has been added to every lesson.
- Self-test questions at the end of each lesson have been rewritten.
- The overall look (page layout, graphics, type, etc.) has been greatly changed.

Excerpts from three publications should be given special acknowledgment. Parts of *Preservation and Treatment of Lumber and Wood Products*, Chapter 3 — “Pests That Damage Wood” published by Cooperative Extension, New York State College of Agriculture and Life Sciences at Cornell University, Ithaca, New York, were used and are gratefully acknowledged.

Portions of Wood Preservation and Wood Products Treatment Training Manual, published by Oregon State University Extension Service, were used and are sincerely appreciated.

I also wish to thank The American Wood Preservers Association for their permission to use excerpts of the Glossary (M5-92) found in the AWPA Standards and for their permission to summarize the report Wood Preservation Statistics, 1990, by J.T. Micklewright.

A special thanks is also due the following individuals for their encouragement, comments, and patience (all are involved with Minnesota’s Pesticide Applicator Training Programs):

Fred Hofer, Gene Anderson, Dean Herzfeld, Minnesota Extension Service, University of Minnesota, Wayne Dally, and Steve Poncin, Minnesota Department of Agriculture (Minnesota’s lead agency in Pesticide Applicator Training Programs.)

And finally, a special thanks to all the highly talented people on the production team who were instrumental in producing this manual. All are with the Minnesota Extension Service, Educational Development System (except where noted):

Text Entry: Mary Ferguson (Dept. of Forest Products), Rosemary Kumhera, Kathleen Cleberg

Proofing: Nancy Goodman (contract editor)

Illustrations: Len Gotsinski (formerly with MES)

Graphic Design: Deb Thayer

Production Coordinators: Judy Keena, Gail Tischler

We hope you find this training manual useful and informative.

F. Thomas Milton  
Extension Specialist, Associate Professor  
Department of Forest Products, College of Natural Resources  
University of Minnesota



# Table of Contents

	Page
<b>INTRODUCTION TO MANUAL</b>	vi
<b>Lesson 1: TREE GROWTH AND WOOD MATERIAL</b>	1
Introduction	1
Wood—Our Most Valuable Natural Resource	1
Advantages of wood	1
Disadvantages of wood	1
Wood: Many Varieties Create Wide Variations in Properties	2
Names for trees	2
Softwood and hardwood trees	3
Growth Process of Trees	3
Cell Structure	6
Differences between softwood and hardwood cells	6
Cell wall structure	8
Chemical Composition of Wood	9
Self-Testing Questions	10
<b>Lesson 2: WATER AND WOOD</b>	11
Introduction	11
Moisture Content	11
Wood/Moisture Relations	11
Swelling and shrinkage of wood	13
Seasoning	14
Air drying	14
Kiln drying	14
Effects of wood seasoning and moisture content	14
Seasoning distortion of wood	14
Products of Wood	16
Self-Testing Questions	18
<b>Lesson 3: DETERIORATION OF WOOD BY FUNGI, INSECTS                   AND MARINE BORERS</b>	19
Introduction	19
Fungi	19
Decay fungi	19
Stain and mold fungi	21
Insects	22
Subterranean termites	22
Drywood termites	23
Wood-boring beetles	23
Carpenter ants	25
Carpenter bees	26
Marine Borers	26
Molluscan borers	27
Crustacean borers	27
Self-Testing Questions	29



<b>Lesson 4: WOOD PRESERVATIVES</b>	31
Introduction	31
Natural Durability	31
Development of Wood Preservatives	31
Carrier Liquids or Solvents	33
Major Chemical Preservatives	34
Creosotes	34
Pentachlorophenol (PCP or penta)	34
Inorganic arsenicals	37
Other preservatives	38
Preventing Destruction by Fire and Weathering	39
Fire retardant treatments	39
Water-repellent finishes	39
Health and Safety Factors	39
Self-Testing Questions	41
<b>Lesson 5: PRESERVATIVE TREATING PROCESSES</b>	43
Introduction	43
Flow of Liquids Into Wood	43
Softwoods	43
Hardwoods	44
Methods of Applying Preservatives	45
Brush-on and spraying	45
Cold soaking and steeping	45
Thermal process or hot-and-cold bath	48
Vacuum-Pressure Methods	49
Full cell process	49
Empty cell processes	51
Modified full cell process	51
Vacuum-Pressure Treating Plant Equipment	53
Preparation or Pretreatment of Wood for Vacuum-Pressure Application	53
Boultonizing	54
Steaming	54
Incising	54
Units of Measure Used in Wood Preservation	54
Units of vacuum	54
Units of pressure	55
Units of liquid volume	55
Units of wood volume	55
Units of retention	55
Units of shipping volume for wood items	56
Units of penetration	56
Self-Testing Questions	57
<b>Lesson 6: TREATING REGULATIONS, STANDARDS AND QUALITY CONTROL</b>	59
Introduction	59
Groups Influence Use of Treated Wood	59
Government agencies	59
Utility and railroad industries	59
Architects and builders	59
Farmers	59
Homeowners	59



Codes and Standards	59
Building codes	59
AWPA standards	60
Other standards and specifications	63
Quality Control of Treated Wood by Agencies	63
Quality Control by the Treater	65
Moisture content	65
Charge volume	65
Heartwood content	66
Specified requirements	66
Considerations after treating	66
Self-Testing Questions	67
<b>Lesson 7: THE WOOD-TREATING INDUSTRY</b>	<b>69</b>
Introduction	69
Wood Preservation Statistics: 1990 Summary	69
Preservatives and Product Mix	70
New and Growing Uses for Treated Wood	72
Permanent wood foundations	72
Pile foundations	72
Do-it-yourself projects	72
Aesthetic demands	72
Self-Testing Questions	73
<b>Lesson 8: PROTECTING HUMAN HEALTH AND THE ENVIRONMENT</b>	<b>75</b>
Introduction	75
Background	75
Hazards to Applicators	75
Toxic Effects of Preservatives	76
First aid	76
Protecting the Applicator	76
Personal hygiene	76
Protective clothing and equipment	79
Material Safety Data Sheets	80
Voluntary Consumer Awareness Program	80
Protecting the Environment	80
Waste disposal	80
Storage and disposal of containers	80
Spills	83
Environmental exposure	83
Groundwater pollution	84
Self-Testing Questions	85
<b>Answers to Self-Testing Questions</b>	<b>87</b>
<b>Glossary</b>	<b>89-100.</b>
<b>References</b>	<b>101</b>
<b>Associations</b>	<b>102</b>



---

# Introduction

Treating wood so it can withstand fungal decay and insect damage is critical to producing a high quality wood product. It is also a potentially dangerous process that can affect the wood treater's health and the environment.

*The Preservation of Wood* has been written to provide an understanding of current wood preservation practices in the United States. People who treat wood commodities need reliable technical training and this manual is a resource for individuals who must meet the pesticide applicator licensing/certification requirements of the U.S. Environmental Protection Agency and state licensing authorities. The material in this manual applies primarily to pressure-treatment of wood and focuses on the three major restricted-use preservatives: creosote, penta, and the inorganic arsenicals. This manual may also be found useful as a text or reference for vocational students studying wood preservation.

This is not a how-to-do-it manual nor a price guide. It does not give instructions on how treatment should be done. Every piece of treating equipment needs its own instruction manual and each treating chemical should be handled and applied in accordance with labelling instructions for its safe and effective use.

## How to use this manual

This self-study manual consists of eight lessons which include illustrations and tables on the following topics: wood structure; wood/moisture relations and seasoning; deterioration by fungi, insects and marine borers; wood preserving chemicals; preservation treatment processes; regulations and quality control; the wood treating industry and protecting people and the environment.

It is recommended that you follow the sequence of lessons as presented, because each lesson provides a background for subsequent lessons. Study the illustrations and tables along with the text.

A helpful glossary which includes abbreviations and technical terms is provided at the end of the manual. Use it to find definitions and to locate terms in the text. A list of publications for additional study is found at the end of the manual. These published references may be available on loan from good technical libraries, or your own copies may be obtained through library services. Names and addresses of associations involved with the wood preservation industry are also listed at the end of the manual.

## Self-Testing

At the end of each lesson there are multiple-choice, self-testing questions. Answer these questions from memory to test what you have learned. If you don't know the correct answers, study the lesson again until you have mastered the information. Answers to questions for each lesson are given in a section near the end of the manual. When you have correctly answered the questions of one lesson, proceed to the next lesson.

## Feedback and Corrections

If you find errors or omissions in this manual, or have suggestions that would make this manual more useful or helpful please contact: F. Thomas Milton, Department of Forest Products, University of Minnesota, 2004 Folwell Ave., St. Paul, MN 55108.



# Lesson 1:

## Tree Growth and Wood Material

### Introduction

The aim of this lesson is to describe how wood grows in the tree and what wood consists of.

This lesson describes features and functions of whole trees, then discusses the structure of wood and finally explains the microscopic and chemical structure of cell walls. Understanding the structure of wood is essential in understanding the pathways that preservatives follow when wood is treated.

### Wood-our Most Valuable Natural Resource

Throughout recorded history, the unique characteristics and relative abundance of wood have made it one of mankind's most valuable and useful natural resources. Today literally thousands of products that we take for granted come from solid wood, wood pulp and chemicals derived from wood. Why is wood man's most important building material? First, only *wood is a renewable resource*. No other building material — steel, aluminum, brick, concrete, plastics, glass, ceramics—can be regenerated as can trees. And trees also provide wildlife habitat and recreational areas while they grow.

### Advantages of wood

When compared with competing construction materials, wood has many other advantages.

- Wood is available in many species, sizes, shapes and conditions and can suit almost every demand.
- Wood is readily available and is a material most people are familiar with.
- In comparison to other raw materials, wood requires far less energy to process into products.

- Wood has a high strength-to-weight ratio and therefore performs well as a structural material.
- Wood is easily cut and shaped with tools and fastened with adhesives, nails, screws, bolts and dowels.
- Wood is lightweight and easy to install.
- Wood, when dry, has good insulating properties against heat, cold, sound and electricity.
- Wood has good shock resistance and absorbs and dissipates vibrations.
- Because of the variety of grain patterns and colors, wood is an esthetically pleasing material and its appearance can be enhanced by many finishes.
- Wood is easily repaired and wood structures are easily remodeled.
- Wood combines with almost any other material for both functional and esthetic uses.
- Wood can be highly durable if properly protected or treated.

### Disadvantages of wood

Biological deterioration and fire are two obvious threats or disadvantages to wood use.

- Biological deterioration. Because of the sugars and starch in untreated wood, it is a source of food for a variety of fungi, insects and other organisms. Given the right circumstances, they can break down and consume the cellulose, lignin and other components of wood and damage the wood members of a structure. Wood preservation is used to prevent this kind of damage. In Lesson 3 we will look more closely at wood decay, decay fungi and



harmful insects, and in Lessons 4 and 5 we'll see how preservative treatment can deter these destructive agents.

**I Fire.** Wood is combustible when provided with adequate heat and oxygen. In fact, wood is the most widely used fuel in many parts of the world. Wood's combustibility often limits the use of lumber products to light-frame construction such as housing and similar structures. However, some commercial building designs call for and permit the use of heavy timber construction. Untreated large wooden beams are often safer in a fire than unprotected steel beams. When subjected to high temperatures, steel rapidly loses its strength and rigidity. This can lead to the sudden collapse of a building with great risk to life and property. Large cross-sectional timbers, on the other hand, burn slowly from the outside in, often retaining a good proportion of their strength during a fire and after it has been extinguished. For some uses, building codes or standards require wood to be protected by fire retardant treatment.

### **Wood: Many Varieties Create Wide Variations in properties**

Wood may appear to be a very simple material, but its make-up is quite complex. All wood is composed of four chemical components: cellulose, lignin, hemicellulose and extractives, which combine to form a cellular structure. Variations in the characteristics and volume of the four components and differences in cellular structure result in some woods being hard and heavy and some light and soft, some strong and some weak, some naturally durable and some prone to decay. Four primary reasons account for the great variation in wood and its properties.

First, there are many varieties of trees. Each variety, such as red oak, loblolly pine and Douglas fir, is known as a species. There

are approximately 50,000 species of trees in the world and the properties and characteristics of these various woods differ markedly. Within a single species, physical and chemical properties are relatively constant; therefore, selection of wood by species alone may often be adequate. Thousands of different tree species grow in North America; however, only 60 or so have commercial use and even fewer are suitable for treating.

A second reason for variation between pieces of wood occurs within each tree. For instance, it is common for the wood found toward the center of a tree trunk (the heartwood) to be quite different from that found toward the outside (the sapwood).

Another reason for differences within a wood species results from where the tree grows. We could expect radiata pine grown in New Zealand, South Africa and Brazil to be affected by differences in sunlight, latitude, rainfall and wind. The same tree species growing high on a mountain will produce quite different wood characteristics from its twin planted at the same time in a nearby fertile valley.

Finally, after a tree is harvested, the different ways that wood is processed (sawn, seasoned, chemically treated, machined, etc.) will also affect the characteristics of the final wood product. For reasons like these, wood is a variable and complex material, whose properties can never be precisely predicted. Satisfactory treatment must take into consideration the various characteristics of different species and their intended uses.

#### **Names for trees**

People who process, distribute or use wood products on a daily basis refer to tree species or wood by a "common" name. However, sometimes the same name is used to describe wood from several completely different tree species, which may or may not have similar properties or appearance. And sometimes different common names are used for the same tree; for example, yellow poplar may also be



called tulip tree or just poplar. This can be confusing and create problems for buyers, sellers and processors.

The only way to be certain of a wood species is to refer to it by its scientific (or Latin) name. As an example, Eastern white pine and Western white pine may sound like the same tree growing in different areas of the country. In fact, they are different species of trees, which can be distinguished by studying the needles, cones, bark, flowers and wood structure. The scientific name of the former is *Pinus strobus L.* and the latter is *Pinus monticola (Dougl.)*.

### **Softwood and hardwood trees**

A tree is usually defined as a woody plant which, when mature, is at least 20 feet tall, has a single trunk, unbranched for at least several feet above the ground and has a definite crown. Trees are divided into two biological categories: softwoods and hardwoods. The terms softwood and hardwood do not refer to the hardness or density of the wood. Softwoods are not always soft, nor are hardwoods always hard. Mountain-grown Douglas fir, for example, produces an extremely hard wood although it is classified as a “softwood,” and balsawood, so useful in making toy models, is classified a “hardwood” although it is very *soft*.

In biological terms, softwoods are called gymnosperms, which are trees that produce “naked seeds.” The most important group of softwoods are the conifers or cone-bearing trees, which have seeds that are usually visible inside opened cones. All species of pine, spruce, hemlock, fir, cedar, redwood and larch are softwoods. Nearly all softwood trees have another common characteristic: their leaves are actually needles or scales and they remain on the tree throughout the winter, which is why they are also called evergreen trees. Exceptions are larch (or tamarack) and cypress whose needles drop in the fall, leaving the tree bare during winter.

Hardwoods are biologically called angiosperms, which are trees that produce seeds enclosed in a fruit or nut. The hardwood category includes the oaks, ashes, elms, maples, birches, beeches and cottonwoods. In contrast to softwoods, hardwood trees have broad leaves and nearly all North American hardwoods are deciduous, which means they drop their leaves in the fall. However, there are exceptions: holly, magnolia and live oak are hardwoods that retain their leaves year-round.

Though there are many more hardwood species than there are softwoods, the softwoods produce a larger share of commercial wood products, particularly those used for structural applications. This is evident by the dominant use of a few softwood species such as the southern yellow pines, indigenous to the south, and Douglas fir, hemlocks, spruces, other pines and true firs from the west, all of which play crucial roles in construction.

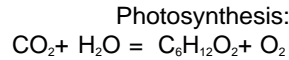
### **Growth Process of Trees**

Tree growth is a miraculous process. Water and nutrients are absorbed by roots and transported from the soil up to the leaves through hollow cells (shaped like long drinking straws with very tiny openings) found in the sapwood (See Figure 1.1, page 4). Leaves absorb carbon dioxide from the air, which they combine with chlorophyll (the green matter of leaves) and sunlight to manufacture food, in the form of various sugars, for the tree’s use. This process is called photosynthesis. A by-product of this process is the release of oxygen. In fact, without the production of oxygen by trees and other green plants on our planet, humans and other animals could not survive.

The nutrients (sugar solutions) manufactured by the leaves are conducted through the inner bark (or phloem cells) to the areas of a tree where growth takes place—the tips of branches and roots and the cambium layer. (See Figure 1.1 and 1.2, page 4.) The cambium is the layer of reproductive cells found between the inner bark (phloem) and sapwood

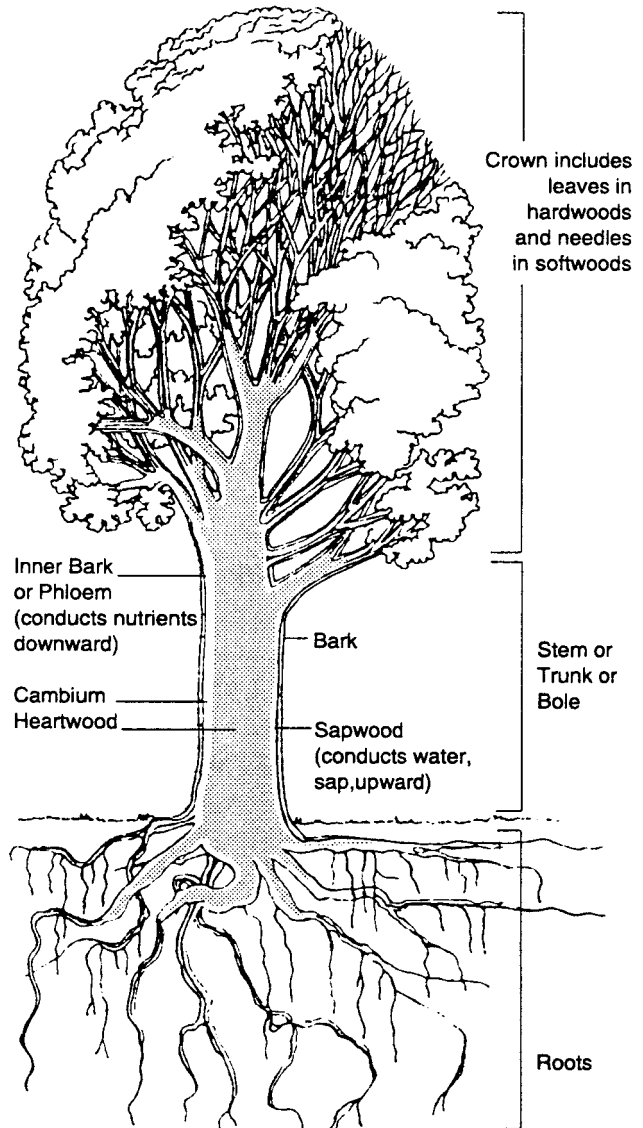


**Figure 1.1**  
Main parts of a tree and the process of photosynthesis.

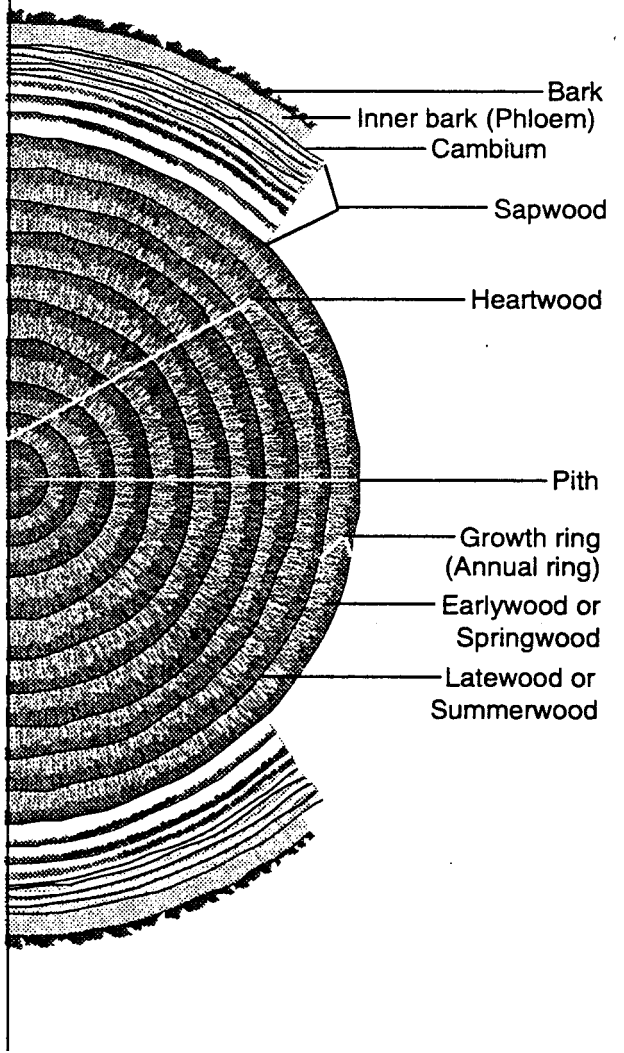


Carbon dioxide (CO<sub>2</sub>) from the atmosphere combines with water (H<sub>2</sub>O) in the leaves during photosynthesis, a process catalyzed by chlorophyll and energized by sunlight, which produces the basic sugar, glucose (C<sub>6</sub>H<sub>12</sub>O<sub>6</sub>), and releases oxygen (O<sub>2</sub>) to the atmosphere.

Figure 1.1 and 1.2  
 Reprinted with permission from *Identifying Wood*  
 by R. Bruce Hoadley. © 1990 The Taunton Press.  
 All rights reserved.



**Figure 1.2**  
Principle features of a tree stem,  
cross-sectional (transverse) view.



portions of a tree. This very narrow layer of cells creates new sapwood cells toward the inside and new phloem cells toward the outside of the cambium. Thus the cambium layer is responsible for a tree's outward growth in diameter and circumference.

As a tree gets bigger around, phloem cells get older; they are pushed farther away from the cambium (toward the outside) and gradually die. Their water transporting function is then taken over by younger phloem cells produced by the cambium. Dead phloem cells become part of the outer protective layer of trees that we call bark. Bark is important in protecting the tender cells in and near the cambium. Without bark, these cells would be under continual attack from insects, forest

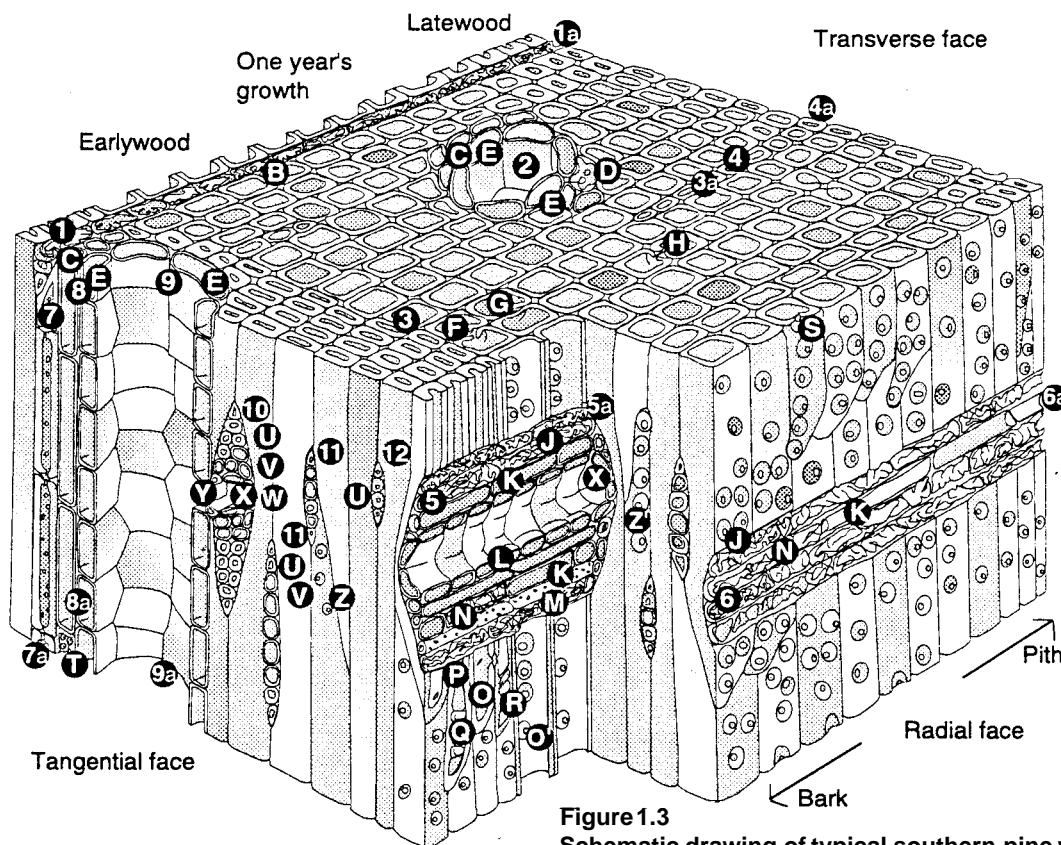


Figure 1.3 Schematic drawing of typical southern pine wood.

Adapted from Koch, Peter. 1972. Utilization of the Southern Pines. USDA Forest Service Ag Handbook No 420. Based on Howard, E.T., and Manwiller, F.G. 1969. WoodScience 2: 77-86.

Transverse view. 1-1a, ray; B, dentate ray tracheid; 2, resin canal; C, thin-walled longitudinal parenchyma; D, thick-walled longitudinal parenchyma; E, epithelial cells: 3-3a, earlywood longitudinal tracheids; F, radial bordered pit pair cut through torus and pit apertures; G, pit pair cut below pit apertures; H, tangential pit pair: 4-4a, latewood longitudinal tracheids.

Radial view. 5-5a, sectioned fusiform ray; J, dentate ray tracheid; K, thin-walled parenchyma; L, epithelial cells; M, unsectioned ray tracheid; N, thick-walled parenchyma; O, latewood radial pit; O', earlywood radial pit; P, tangential bordered pit; Q, callitroid-like thickenings; R, spiral thickening; S, radial bordered pits: 6-6a, sectioned uniseriate heterogenous ray.

Tangential view. 7-7a, strand tracheids; 8-8a, longitudinal parenchyma (thin-walled); T, thick-walled parenchyma: 9-9a, longitudinal resin canal: 10, fusiform ray; U, ray tracheids; V, ray parenchyma; W, horizontal epithelial cells; X, horizontal resin canal; Y, opening between horizontal and vertical resin canals; 11, uniseriate heterogenous rays: 12, uniseriate homogenous ray; Z, small tangential pits in latewood; Z', large tangential pits in earlywood.

animals, fungi and birds and susceptible to physical damage from frost, wind and fire.

The woody portion of a tree is called xylem and it includes both the sapwood and heartwood. Heartwood is the darker-colored inner part of a trunk. This portion of a tree is composed of dead cells, which greatly contribute to the overall strength of the tree trunk. In many ways heartwood is similar to sapwood, but they differ in their chemical and physical properties.

Unlike animals, trees have no way to get rid of by-products or extractives produced by the chemical changes that take place in their living tissues. Some of these by-products could be harmful to the tree, so provision has been made to nullify such risk. The tree moves these substances toward its heartwood center; so heartwood, basically, is just sapwood in which waste substances have accumulated. This leads to two major differences in the properties of heartwood and sapwood. Heartwood, because of the presence of extractives



and other substances, usually has:

- (a) greater resistance to insect attack and decay by fungi, and
- (b) reduced permeability, which can affect timber treatment because the natural cellular channels of heartwood can become clogged with extractive deposits (we will examine this in more detail in Lesson 5).

## Cell Structure

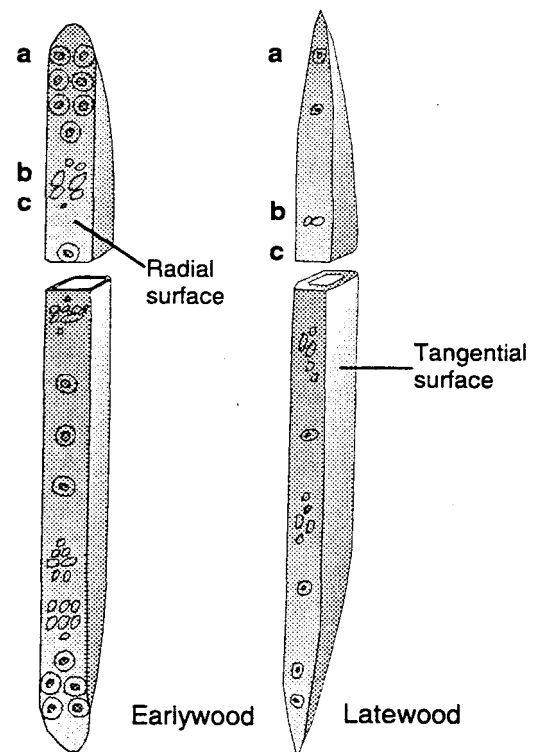
A tree is a plant and all growing organisms, whether plant or animal, consist of cells. During its life, a plant cell is a very small individual unit with a cell wall completely enclosing the liquid inner-cell contents. It is these cells that accept preservatives during wood treatment. Plants grow by the formation of new cells. This occurs when individual cells divide in two, a process called cell division. By this process the plant increases in size and weight. Even a small piece of wood, such as a 1" x 1" x 1" cube, will contain many thousands of tiny cells produced by the continued process of cell division and expansion in the cambium.

As the circumference of the tree grows, the thin ring of cambium grows equivalently. Because of the climatic conditions in the tropics, the rate of growth (that is, the subdivision of cells) is almost constant throughout the year. However, in the United States there are very definite climatic seasons which affect the growth of wood cells. Figure 1.2, page 4 shows the cross-section of a typical tree. Each year the wood cells grow fast early in the growing season (spring), producing springwood or earlywood. Later in the season, as winter approaches, growth slows producing summerwood or latewood. In the depth of winter there may be no woody growth at all. This consistent pattern of fast growth followed by slow growth gives trees their distinctive annual rings. The earlywood cells have thin walls and large central openings or lumens. The latewood cells have thicker walls and smaller lumens. More wall material is produced in the latter part of the growing season.

## Differences between softwood and hardwood cells

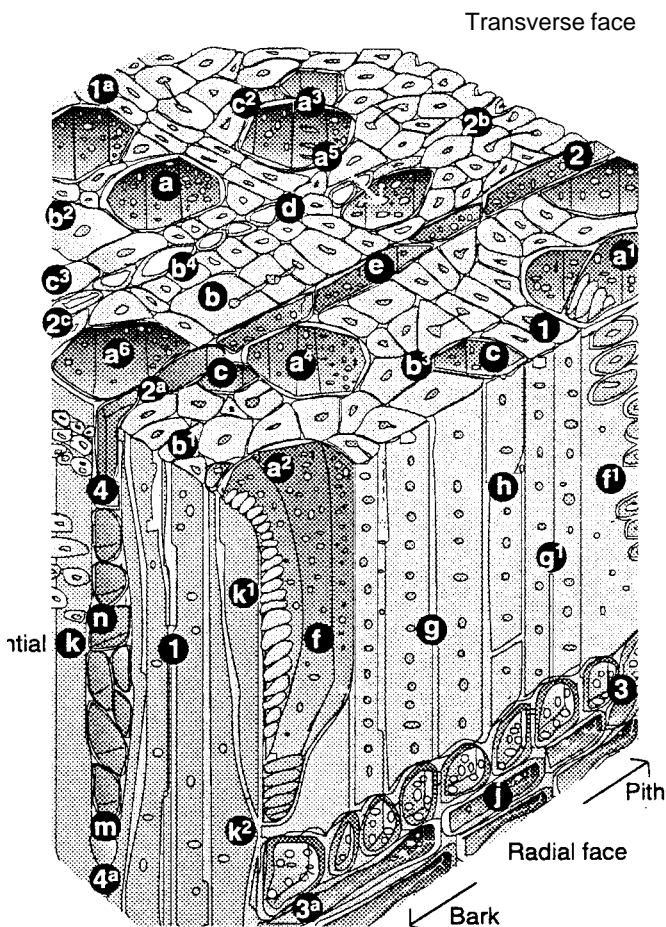
In softwoods, over 90 percent of the wood volume is made up of cells called longitudinal tracheids (pronounced tray-key-ids). See Figures 1.3, page 5, and 1.4. Tracheids are long (3-4 mm in length), thin cells oriented parallel to the vertical axis of the tree. Tracheids give softwood trees their structural support and those found in the inner sapwood area provide the conduits for the vertical movement of water and nutrients.

Other cells in softwoods lie in narrow bundles across the tracheids. These cells are oriented in a radial direction from the outside



**Figure 1.4**  
**Earlywood (left) and latewood (right) tracheids:**  
a, intertracheid bordered pits; b, bordered pits to ray tracheids; c, pinoid pits to ray parenchyma. To simplify the drawing, tangential intertracheid pits have not been depicted. These pits are distributed along the length but are most frequent near the tracheid ends.

Adapted from Koch, Peter. 1972. *Utilization of the Southern Pines*, USDA Forest Service Ag Handbook No 420. Based on Howard, E. T., and Manwiller, F.G. 7969 WoodScience 2: 77-86.



**Figure 1.5**  
**Schematic drawing of a typical hardwood-sweetgum.**  
**(magnified 330X)**

Transverse surface: 1-1<sup>a</sup>, boundary between two annual rings (growth proceeding from right to left); 2-2<sup>a</sup>, wood ray consisting of procumbent cells; 2-2<sup>c</sup>, wood ray consisting of upright cells; a-a<sup>6</sup> inclusive, pores (vessels in transverse section); b-b<sup>4</sup> inclusive, fiber tracheids; c-c<sup>3</sup> inclusive, cells of longitudinal parenchyma; e, procumbent ray cell.

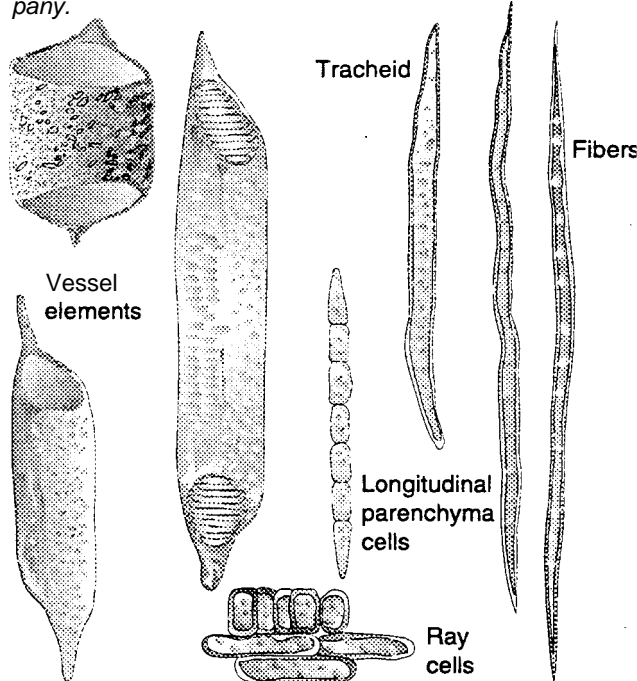
Radial surface: f, f', portions of vessel elements; g', portions of fiber tracheids in lateral surface aspect; 3-3<sup>a</sup>, upper portion of a heterocellular wood ray in lateral sectional aspect; i, a marginal row of upright ray cells; j, two rows of procumbent ray cells.

Tangential surface: k, portion of a vessel element in tangential surface aspect; k'k<sup>2</sup>, overlapping vessel elements in tangential surface aspect; 1, fiber tracheids in tangential surface aspect; 4-4<sup>a</sup>, portion of a wood ray in tangential sectional view; m, an upright cell in the lower margin; n, procumbent cells in the body of the ray.

Adapted from Koch, Peter. 1985. *Utilization of Hardwoods Growing on Southern Pine Sites*. USDA Forest Service. Ag Handbook No. 605. From Panshin, A.J. and de Zeeuw, C. 1980. *Textbook of Wood Technology*. Used with the permission of McGraw-Hill Book Company.

of the tree trunk towards its center and are referred to as ray cells or rays. They transport waste materials (extractives) toward the heartwood and may be used for storage of various food substances. Rays are bundles of cells usually only one cell wide and seldom more than three. Because softwood rays are so narrow, they are usually invisible to the naked eye. Horizontal transport of liquids across the annual rings is accomplished by the ray cells.

Hardwood trees are more highly developed than the softwoods and their cell structure is more complex and variable. See Figures 1.5 and 1.6. They have evolved a special way of conducting water from the roots to the leaves. Large, hollow cells (called vessels) lie within a mass of fiber tracheids. In hardwoods all vertical water conduction is done through these vessels. Each vessel is made up of short segments joined end-to-end (like drain pipes). The vessels are much larger in diameter than



**Figure 1.6**  
**Hardwood cell types are extremely varied.**  
The drawing indicates their relative size and shape.  
Reprinted with permission from *Understanding Wood* by R. Bruce Hoadley. © 1980 The Taunton Press. All rights reserved.



the fiber tracheids and can often be seen as tiny holes on the ends of wood in tree species like ash, oak or elm. In contrast to the longitudinal tracheids found in softwoods, which provide support and conduct liquids, the fiber tracheids in hardwoods primarily provide support.

The ray cells of hardwoods are not unlike those in softwoods, but hardwood ray cells often form much wider bands or ribbons. They can be so wide as to be visible to the naked eye. In fact, the rays are responsible for much of the distinctive *grain pattern* or *figure* of our common hardwood species. Were it not for the different colors and structural features of exposed vessels and rays, most species of hardwood would look similar.

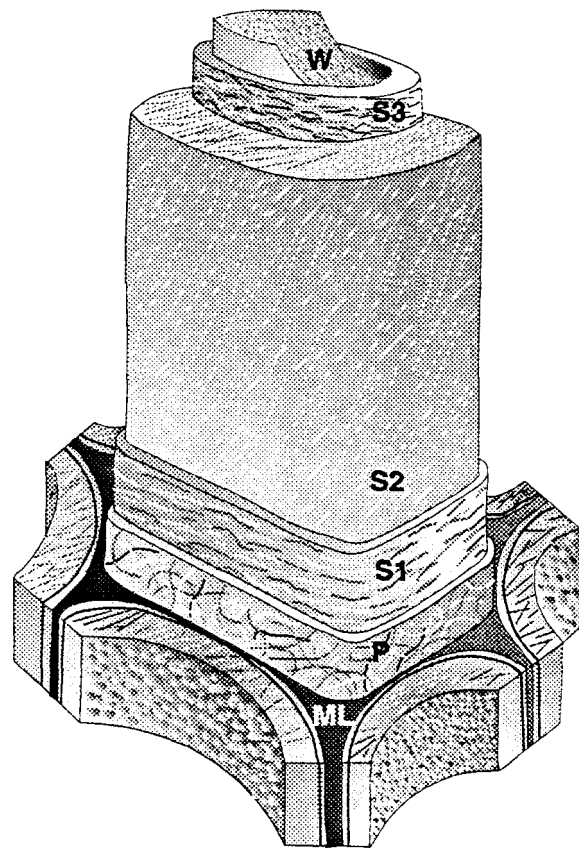
### Cell wall structure

The wall of a typical wood cell is composed of several layers, which are formed as new cells are created at the cambium layer. (See **Figure 1.7**). The *middle lamella*, composed mainly of lignin, serves as the glue bonding adjacent cells together. The wall itself is made up of a *primary wall* and a three-layered *secondary wall*, each of which has distinct alignments of microfibrils. *Microfibrils* are ropelike bundles of cellulose molecules, interspersed with and surrounded by hemicellulose molecules and lignin.

In the primary wall the microfibrils form a loose, irregular net-like orientation. In the outer (S1) layer of the secondary wall, the microfibrils are more precisely oriented, but are nearly perpendicular to the long axis of the cell. In the S2 layer, the microfibrils run almost parallel to each other in a tight spiral around the cell. This layer is the thickest and has the greatest effect on how the cell, and therefore the wood, behaves.

The smaller the angle the microfibrils make with the long direction of the cell, the stronger the cell is. In the innermost (S3) layer of the cell wall the microfibrils are once again oriented almost at right angles to the cell's long axis.

As the cell wall is forming, small openings called *pits* are created. (See **Figure 1.8**). Pits are thin spots where the secondary wall has not formed. Pits are normally matched in pairs between adjacent cells and allow liquids to pass freely from one cell to the next. Obviously the function of pits is very important, especially to the wood treater. However, because they are very small in some species they can be easily plugged by deposits in the heartwood, making the cell wall almost impermeable to liquids and therefore difficult to treat.



**Figure 1.7**  
**Cell wall organization.** Idealized model of typical wall structure of a fiber or tracheid. The cell wall consists of: P-primary wall; S1, S2, S3-layers of the secondary wall; W-warty layer (not always evident); ML-middle lamella, the amorphous, high-lignin-content material that binds cells together. Adapted from Koch, Pefer. 7985. *Utilization of Hardwoods Growing on Southern Pine Sites*. USDA forest Service. Ag Handbook No. 605. from *Wood Ultrastructure - An Atlas of Electron Micrographs*, by Cote, W.A. 1967. By permission of University of Washington Press, Seattle.



## Chemical Composition of Wood

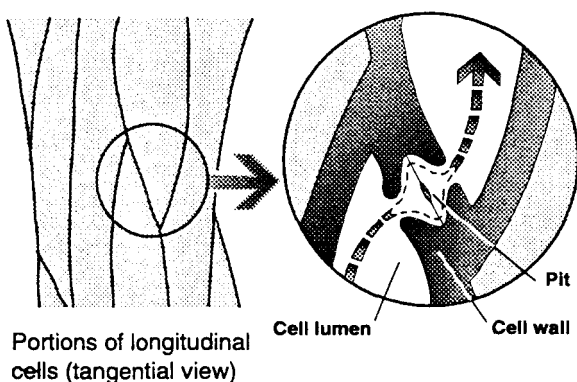
Earlier in this lesson we learned that photosynthesis, which occurs in the leaves (or needles), produces glucose ( $C_6H_{12}O_6$ ), a solution of sugar in water. Glucose is carried via the phloem tissue (or inner bark) to the growing tissues in the tree, that is, the cambium layer and the tips of branches and roots, where a very important chemical process occurs.

Glucose molecules (as many as 30,000) link end to end with each other in long straight chains to form cellulose molecules. Because so many glucose molecules will link together, cellulose is said to have a high degree of polymerization. However, even the longest cellulose molecules, which are about 10 microns long, (1 micron = .001 mm) are too small to be seen even with an electron microscope.

Cellulose, the main building material of all plant cells including trees, makes up about 50 percent of the dry weight of wood. Because bonding between and within glucose molecules is so strong, cellulose molecules are very strong and they are the reason wood is so strong. Lateral bonding between cellulose molecules is also quite strong, causing them to group together to form strands that, in turn, form the thicker, ropelike structures called

**Figure 1.8**  
Pits provide tiny passageways for flow of water and liquids

*Reprinted with permission from Forest Products and Wood Science, 2nd Edition, by J. G. Haygreen and J. L. Bowyer. © 1982, 1989 Iowa State University Press, Ames, Iowa 50010.*



microfibrils. Microfibrils can be seen with an electron microscope.

Hemicellulose, the second chemical component of wood, makes up 15 to 25 percent of the dry weight of wood. Unlike cellulose, which is made only from glucose, hemicellulose consists of glucose and several other water-soluble sugars produced during photosynthesis. The degree of polymerization (that is, the number of sugar molecules connected together) is lower for hemicellulose and they form branched chains rather than straight chains. Hemicellulose surrounds strands of cellulose and helps in the formation of microfibrils.

The third chemical component of wood is lignin, a complex chemical, completely different from cellulose. Lignin makes up about 15 to 30 percent of the dry weight of wood. It occurs in the wood throughout the cell wall, helping to cement microfibrils together. However, it's also concentrated toward the outside of cells and between cells. Lignin is a three-dimensional polymer, though its exact structure is not fully understood. Lignified plants differ from those which do not have lignin, (for example, grasses). Wood would be similar to cotton (which is almost 100 percent cellulose) if it wasn't for lignin. Lignified plants such as trees and shrubs are stiff and are able to grow tall. Lignin is thermoplastic, which means it becomes pliable at high temperatures and hard again when it cools.

Extractives are various organic and inorganic chemicals found in the cell walls and cell lumens that are not structural components of wood. They can make up 2 to 15 percent of wood's dry weight. Organic type extractives contribute to such properties of wood as color, odor, taste, decay resistance, density, hygroscopicity (ability to absorb water) and flammability. Some examples of extractives include tannins, lignins, oils, fats, resins, waxes, gums, starch and terpenes. Collectively these substances are called extractives because they can be removed from wood by heating it in water, alcohol or other solvents.

# Self-Testing Questions - Lesson 1

(Some questions may have more than one answer)

**1. There are approximately how many tree species of commercial importance in North America?**

- (a) 17                      (b) 50,000  
(c) 550                      (d) 60

**2. All conifers or evergreens retain their needles** and all hardwoods lose their leaves in the fall.

- (a) True                      (b) False

**3. Balsa is a hardwood tree species.**

- (a) True                      (b) False

**4. The process of photosynthesis:**

- (a) Occurs in the cambium  
(b) Produces extractives  
(c) Produces glucose  
(d) Produces carbon dioxide  
(e) Occurs at night  
(f) Produces oxygen

**5. What is the main function of the outer bark of a living tree?**

- (a) Food storage              (b) Cell division  
(c) Protection                (d) Sap flow

**6. What useful part do heartwood cells play in a living tree?**

- (a) Hold extractives        (b) Sap flow  
(c) Strengthen trunk        (d) Food storage

**7. For each of the properties listed below, circle the letter which indicates whether the sapwood or heartwood exhibits more of that property.**

**Higher moisture content on felling**

- (a) Sapwood    (b) Heartwood

**Greater permeability to liquids**

- (c) Sapwood    (d) Heartwood

**Higher content of waste products**

- (e) Sapwood    (f) Heartwood

**Greater natural resistance to decay**

- (g) Sapwood    (h) Heartwood

**Lighter colored appearance**

- (i) Sapwood    (j) Heartwood

**8. The woody portion of a tree is called:**

- (a) Summerwood    (c) Phloem  
(b) Springwood    (d) Xylem

**9. Which one of these processes is essential to the production of new cells?**

- (a) Wall thickening        (b) Cell division  
(c) Winter weather        (d) Sap flow

**10. Which of these substances might be found in a living sapwood cell?**

- (a) Extractive              (b) Carbon dioxide  
(c) Starch                    (d) Water

**11. Which group of cells conducts nutrients downwards in a hardwood tree?**

- (a) Rays                      (b) Longitudinal tracheids  
(c) Vessels                    (d) Phloem cells

**12. Small openings in the cells walls are called**

- (a) Holes                      (b) Liquid passageways  
(c) Pits                        (d) Lumens

**13. Which chemicals are transported from the leaves to act as energy sources for all growing parts of a tree?**

- (a) Sugars (glucose)        (b) Water  
(c) Chlorophyll              (d) Extractives

**14. Which product will tend to keep its strength longest in a building fire?**

- (a) A heavy (large) wooden beam  
(b) An unprotected heavy steel beam

**NOTE:** Answers are given at the end of the program.



# Lesson 2: Water and Wood

## Introduction

This lesson explains why wood has an attraction to water, why water must be removed from wood before treating and how to avoid drying defects.

## Moisture Content

All living trees contain a considerable amount of water or sap. In fact, wood from freshly felled trees may contain more water (by weight) than wood substance (cellulose and other solid components). The amount of moisture in wood is termed the moisture content (MC). The moisture content of lumber products is based upon a percentage of the oven-dry weight of the wood and is simply the weight of the water found in the wood divided by the oven-dry weight of the wood.

To measure moisture content of wood accurately, two pieces of equipment are required:

- an accurate weighing balance or scale and
- a drying oven capable of maintaining a

temperature of 214°-218° F for evaporating all the water.

First, weigh a small sample of the wood in question and record its weight. This is its green weight or original weight. The wood may actually be partially dry. Next, dry it in an oven at about 216° F and record its weight again. The wood sample is considered oven-dry when, after continued drying and reweighing at various intervals, the weight remains constant, indicating that all of the available water has evaporated. The oven-dry condition can usually be attained in 12–18 hours depending on thickness of the wood samples. Percent moisture content is then determined from the formula at the bottom of this page.

The moisture content of wood from freshly felled trees ranges widely (Table 2.1, see page 12). Moisture meters are used by many wood processors, and if properly used and calibrated they can give fairly accurate readings for moisture contents between 5–25%. Above 30% MC, moisture meters are very inaccurate.

## Wood-Moisture Relations

Water is held in wood in two ways. Water found inside the cell cavities or lumens is called *free water*. Like water inside a glass tube it is relatively free to drain out or evaporate. (See **Figure 2.1a** page 13). When water is drained from the glass tube, the tube is essentially dry. The glass walls do not absorb any water. However, wood cell walls behave quite differently (See **Figure 2.1b**, page 13). Even though free water may be absent or evaporated from the cell cavity, the cell walls themselves can contain a lot of water, tightly bound up between the cellulose molecules. Water held within the cell walls is called *bound water*, because it is tightly held by adsorption forces. *Adsorption forces* are strong chemical forces that are created between water molecules and hydrogen bonding sites on cellulose, hemicellulose and lignin molecules. Adsorption is different from absorption. *Absorption* is a physical (not a chemical) force that is created by strong surface tension forces. Absorption forces cause a sponge to soak up water and create the capillary action of liquid water moving through cell lumens.

Because of wood's strong attraction or affinity to water, wood is said to be *hygroscopic*, which means it's sensitive to moisture in the air. Wood is constantly gaining or losing moisture in an attempt to reach a state of balance or equilibrium with the conditions of the surrounding air.

$$\% \text{ MC} = \frac{\text{Green weight of wood} - \text{OD weight of wood}}{\text{OD weight of wood}} \times 100 = \frac{\text{weight of water}}{\text{OD weight of wood}} \times 100$$



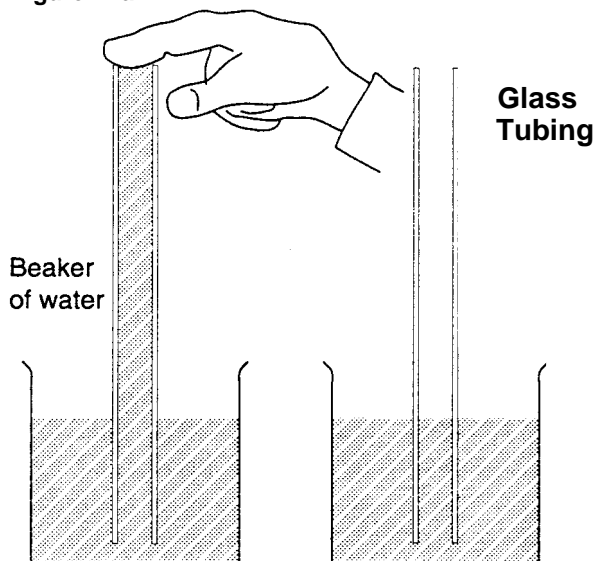
**Table 2.1**  
**Average moisture content of green wood and shrinkage values of selected species suitable for treating**  
**(referenced in AWPA Standards).**

Species	Moisture Content (percent) based on oven-dry weight			Shrinkage (percent) <sup>1</sup> dried to 15% MC	
	Heartwood	Sapwood	Mixed Heartwood & Sapwood	Radial	Tangential
<b>SOFTWOODS</b>					
Cedar					
Northern white	32	240	93	1.1	2.4
Western red	58	249	62	1.2	2.5
Douglas fir					
Coast type	37	115	45	2.4	3.8
Intermediate type	34	154	—	2.4	3.7
Rocky Mountain type	30	112	43	1.9	3.4
Fir					
Balsam	88	173	117	1.4	1.9
California red	—	—	108	2.2	3.9
Grand	91	136	—	1.7	3.7
Noble	34	115	—	2.1	4.1
Pacific silver	55	164	—	2.2	4.6
White	98	160	—	1.6	3.5
Hemlock, western	85	170	—	2.1	3.9
Larch, western	54	119	—	2.2	4.5
Pine					
Eastern white	50	175	90	1.0	3.0
Lodgepole	41	120	—	2.1	3.3
Ponderosa	40	148	—	1.9	3.1
Red	32	134	—	1.9	3.6
Southern					
Loblolly	33	110	—	2.4	3.7
Longleaf	31	106	—	2.5	3.7
Shortleaf	32	122	—	2.3	3.8
Sugar	98	219	—	1.4	2.8
Western white	62	148	—	2.0	3.7
Redwood, old-growth	86	210	—	1.3	2.2
<b>HARDWOODS</b>					
Hickory species					
(averages)	70	50	—	3.8	5.5
Oak					
Northern red	80	69	—	2.0	4.3
White	64	78	—	2.8	5.2
Sweetgum	79	137	—	2.6	5.1

<sup>1</sup>Based on dimensions when green  
Source: Adapted from Simpson, William T. 1991. *Dry Kiln Operator's Manual*. USDA Forest Service. Ag. Handbook No. 188.



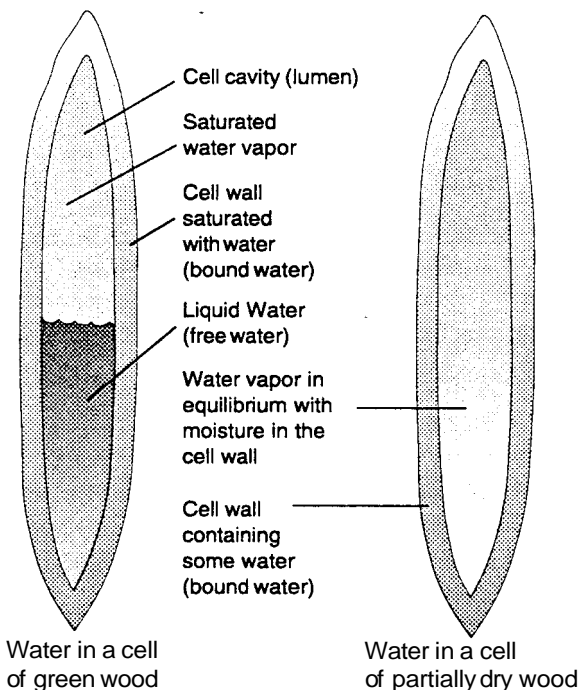
**Figure 2.1a**



Glass is not able to absorb water, so when water is drained from glass tubing, it leaves the walls free of water.

**Figure 2.1b**

**The concept of free and bound water.**



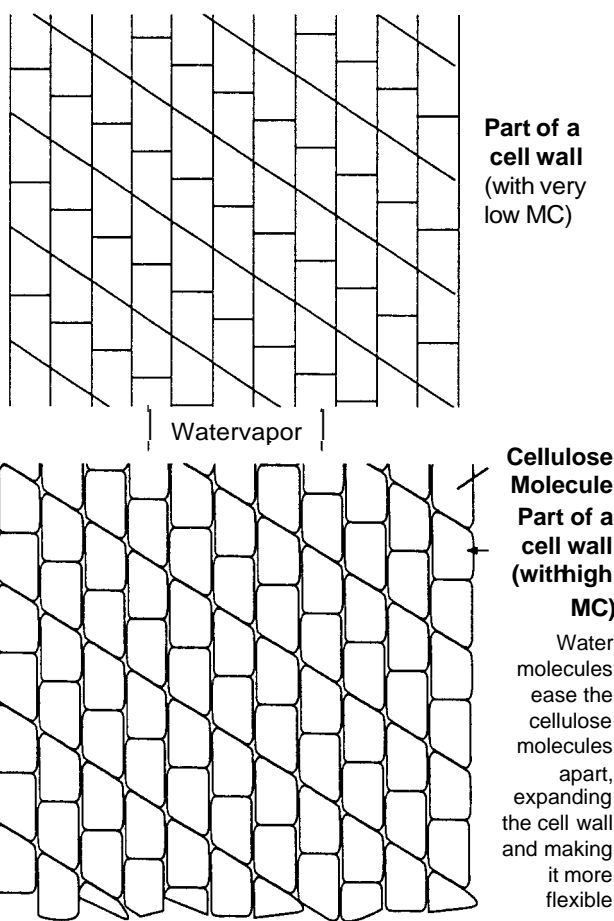
A wood cell behaves differently. The cellulosic cell wall has a strong attraction for water. Even if the water in the cell cavity (free water) escapes, there still can be a lot of water trapped in the cell wall (bound water).

Reprinted with permission from *Forest Products and Wood Science* by J.G. Haygreen and J.L. Bowyer. © 1982, 1989 Iowa State University Press, Ames, Iowa 50010.

Wood adsorbs water vapor when the air around it is damper than the wood, and loses or desorbs water if the air becomes drier (see Figure 2.2). The moisture content of wood at the point where it is in balance with the surrounding air (neither gaining or losing moisture) is called the equilibrium moisture content or EMC.

**Swelling and shrinkage of wood**

Because of the two different forms in which water is held in wood cells (free water and bound water), the process of drying also occurs in two stages. First, nearly all the free water will be evaporated. The MC at which the cell cavity



**Figure 2.2**

**Wood swelling by bound water.** Dry wood can adsorb moisture vapor from moist air. In the lower diagram, water has entered the cell wall and cellulose molecules are seen to be forced apart, swelling the cell wall and therefore the wood as a whole.



contains no free water and the cell wall still has all the bound water it can hold, is known as the *fiber saturation point* or FSP. The FSP occurs at about 25–30% MC. If the MC of wood is higher than the FSP, some free water must be present. At the FSP and above, wood is in its most swollen condition.

Important: Though the FSP occurs at the cell level, an average FSP is used when discussing the moisture condition of a lumber product. For example, as a nominal 2 x 6 is kiln-dried, the outer shell of the lumber will reach the FSP and attempt to shrink long before the wet inner core of that lumber reaches the FSP.

The inner core restrains the outer shell from shrinking appreciably until the core also falls below the FSP. Only when the average moisture content for the whole piece of lumber falls below the FSP (25–30%) will any noticeable shrinkage occur. It's important to realize that the difference in moisture content between shell and core causes stresses and strains, because one area can't shrink as freely as another. This can result in seasoning defects such as checks, honeycomb and collapse.

## Seasoning

Before wood is used for most construction purposes, and especially before it can be pressure-treated, its moisture content has to be reduced from its freshly felled or "green" condition to a much lower level, commonly 15% to 25%. As soon as a tree is cut down, it begins seasoning or drying, and water in the wood starts to evaporate. However, seasoning can be accelerated and more closely controlled by proper air drying, kiln drying, or a combination of the two.

### *Air drying*

This method of drying literally means stacking lumber out-of-doors in such a way that it is dried by the ordinary flow of air. Depending on species and weather conditions, air dried wood may take from several weeks to several months to reach the dryness desired for its intended use.

### *Kiln drying*

Kiln drying is a drying process accelerated and controlled by enclosing the lumber in a building called a kiln and circulating heated air through the piles of lumber (see Figure 23). To avoid splitting the wood by drying it too fast (removing water too quickly), steam is often injected into the kiln to re-dampen the air. Kiln drying of fast-growing softwoods, such as the southern yellow pines, will normally take one to four days to reach 15% MC. It takes much longer to dry dense hardwoods if serious splitting, warping and other drying defects are to be avoided. Lumber or other wood products exposed to an outdoor environment and humidities will eventually reach an equilibrium moisture content of around 12% (in the midwest).

In contrast, millwork and furniture found in an indoor environment with normal humidities will be exposed to EMCs of 4–8%. Therefore the lumber used to make these products must be dried to 4–8% MC. To save energy and drying costs, dense hardwood lumber is often air-dried first to reduce some moisture, then it is kiln-dried.

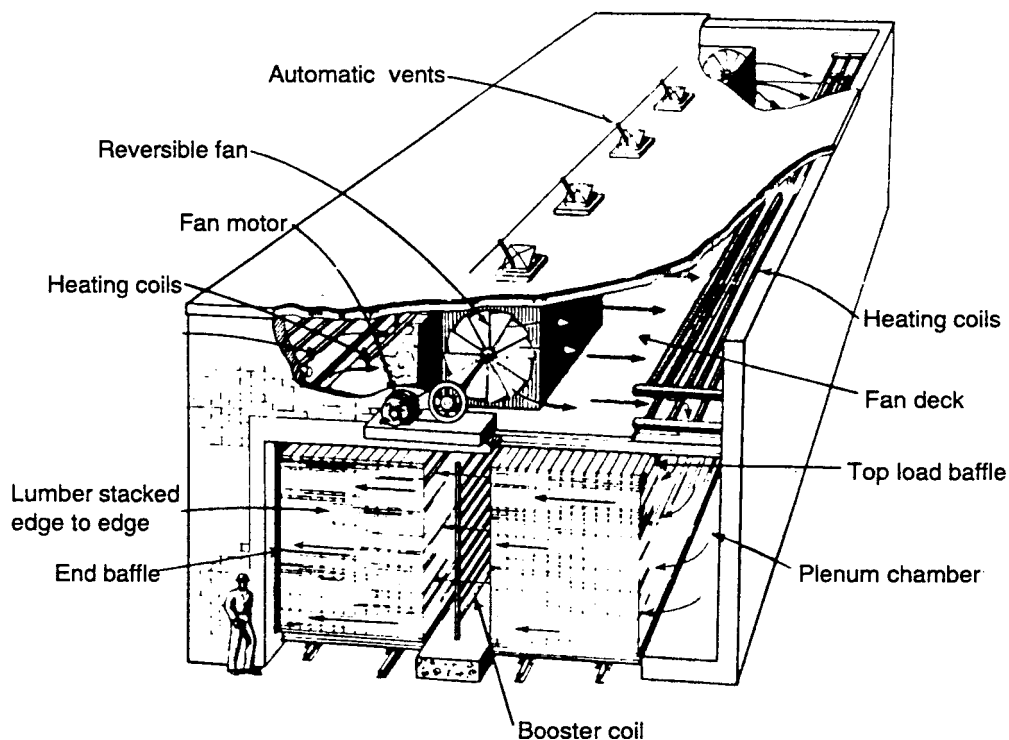
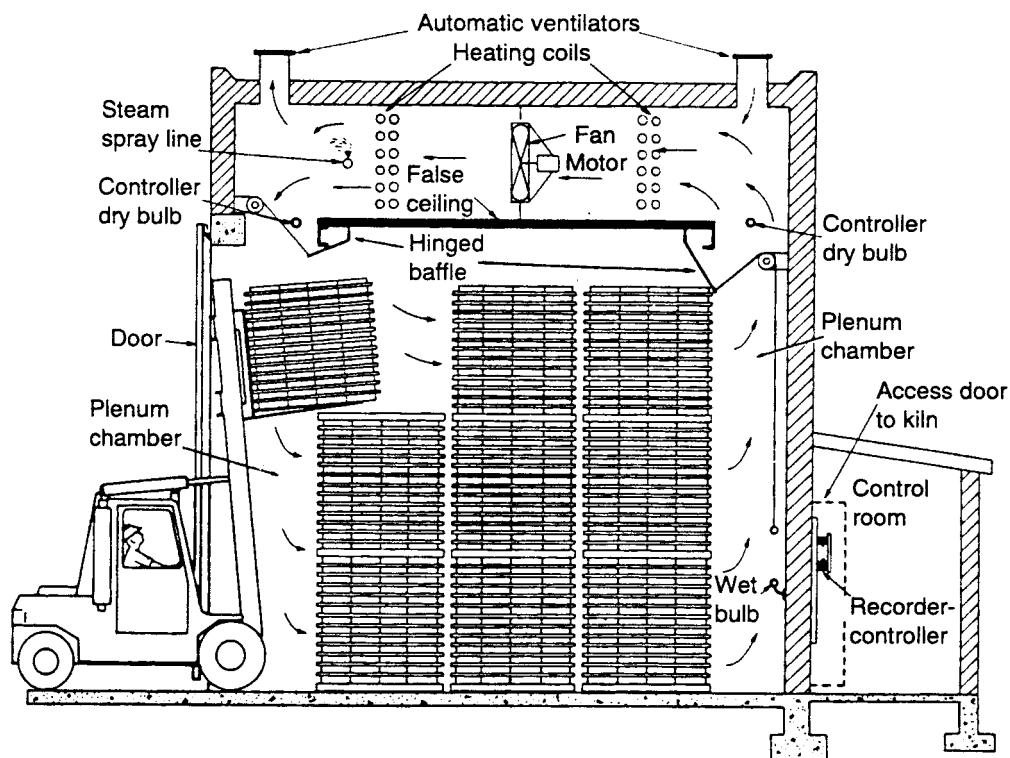
For rapid air-drying or kiln-drying, separation of individual lumber items, timbers or rounds is essential. This is usually done by inserting narrow sticks or stickers about 2' apart between each layer of lumber in the stack or package.

### *Effects of wood seasoning and moisture content*

Moisture content, obviously, also affects the weight of wood and its *strength* and *flexibility*. Wood is strongest for most uses when it is dry, and is also most rigid in this condition. Frequent swelling and shrinking of wood can cause it to crack and split. This most often happens out-of-doors, where rain wets and swells the wood surfaces and the sun and wind shrink and dry the wood.

### *Seasoning distortion of wood*

Thin wood items dry faster than thicker stock. Because of this, and the need for maximum utilization, lumber and similar products are sawn to dimensions close to the desired final size before seasoning is started.



**Figure 2.3**  
**Conventional heated dry kilns.** (Top) Package-loaded compartment kiln for charging by fork lift. (Bottom) Track-loaded compartment kiln with alternately opposed fans mounted on a long shaft. Steam "booster" coils are located between the two tracks to raise temperature and lower humidity of air before it enters the second pile. Many fan arrangements, besides the one shown, are in use. From: Simpson, William T. 1991. *Dry Kiln Operators Manual*. USDA Forest Service, Ag. Handbook No. 188.



It is important to realize that some distortion of shape and dimension will occur even with careful drying of any piece of wood. During seasoning, as the bound water in the cell walls is removed, wood will shrink in three dimensions: lengthwise, radially and tangentially (see Figure 2.4). Shrinkage lengthwise (or longitudinally) is usually considered negligible. Radial shrinkage (change in the dimension at right angles to the annual growth rings of the wood) is usually less than tangential shrinkage. The dimensional change (loss) in width and thickness during drying is typically 2–6% (See **Table 2.1**, page 12). Apart from the unavoidable and acceptable changes in size and shape during seasoning, more serious defects can occur by attempts to season wood too quickly. These defects can result in considerable waste of raw material and money. The most common seasoning distortions are shown in **Figures 2.5a 2.5b and 2.5c**

## Products of wood

Wood-based industries in the U.S. are very important to the nation's economy. Commercially, wood is rarely referred to simply as "wood." Other words are used that tell us the product, shape or form a wood-based material takes. The softwoods provide most of the wood materials used for building construction. Their most common forms are:

**Boards.** *Boards* refer to lumber that is usually 6' or longer (in 2' increments), up to, but not including 2" thick and usually at least 3" wide. After being sawn to rough sizes, boards may be smoothed or surfaced by planing or surfacing.

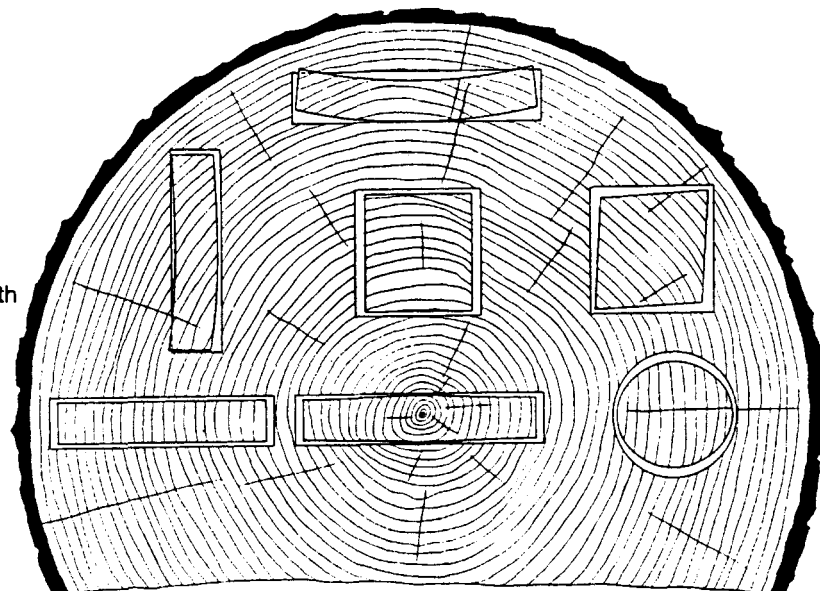
**Dimension.** Dimension is a classification of lumber that is nominally 2" up to, but not including, 5" in thickness. The most common thickness of dimension lumber is 2" nominal size. (Nominal dimensions are marketing or "name" sizes of thicknesses and widths — in contrast to actual dimensions which are true sizes. For example, the actual dimensions of a nominal 2 x 4 are 1-1/2" x 3-1/2". (For lengths, nominal and actual sizes are the same). Common nominal sizes of dimension lumber are 2" x 6", 2" x 8", 2" x 10" and 2" x 12", and their actual sizes are 1-1/2" x 5-1/2", 1-1/2" x 7-1/2", 1-1/2" x 9-1/4" and 1-1/2" x 11-1/4" respectively. Like boards, dimension lumber may also be surfaced.

**Timbers.** Timbers are any square or rectangular items of solid wood with a minimum thickness of 4". Common cross-sections are 4" x 4" and 6" x 6", but they may be 4" x 8", 12" x 12" or larger. Timbers are normally sold for use in their rough-sawn condition for heavy construction.

**Millwork.** Millwork describes the large variety of specialty wooden items produced in factories that make door and window frames, moldings, siding, dowels and other items used in the internal or external finishing of buildings.

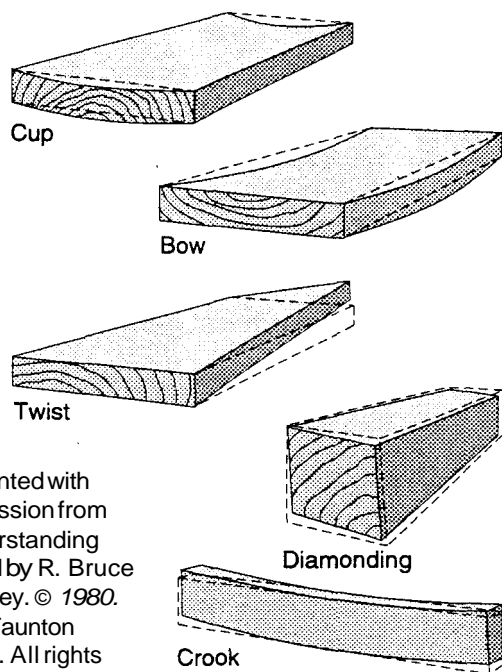
**Figure 2.4**  
Characteristic shrinkage and distortion of flats, squares and rounds as affected by the direction of the growth rings. Tangential shrinkage is about twice as great as radial.

From: Peck, E.C. 1947.  
*Shrinkage of wood.* USDA  
Forest Service. FPL Report No.  
R1650.



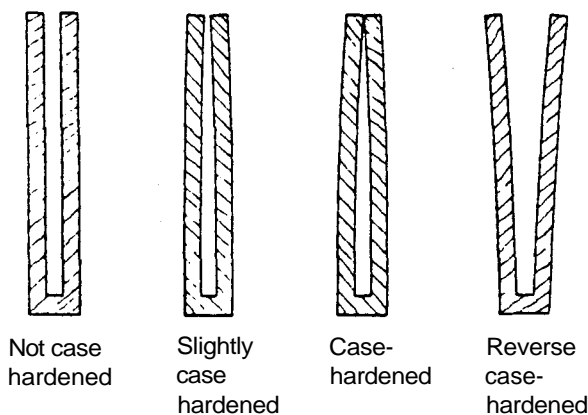


**Figure 2.5a**  
**Types of warp that develop in boards during drying.**  
 Warp is caused by differences between radial tangential and longitudinal shrinkage as the board dries, or by growth stresses. It can be minimized by certain sawing techniques and proper stacking.



Reprinted with permission from Understanding Wood by R. Bruce Hoadley. © 1980. The Taunton Press. All rights reserved.

**Figure 2.5c**  
**Residual drying stress.**  
 The severity of residual drying stress (or case hardening) is indicated by cutting a stress section from the cross-section of a board, and noting how far the prongs bend in or out.



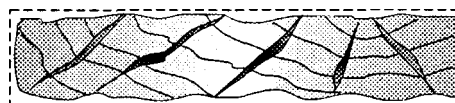
Adapted from Simpson, William T. 1991. Dry Kiln Operator's Manual. USDA Forest Service. Ag. Handbook No. 188.

**Figure 2.5b**  
**Defects caused by rupture between or within wood tissue.**

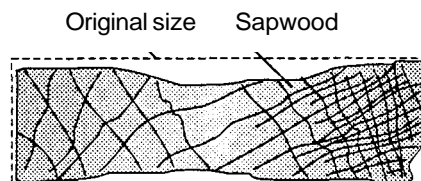
Honeycomb is an internal crack caused by tensile failure across the grain of the wood, usually in the wood rays. It is caused by drying temperatures that are too high for too long when the core still has a high moisture content.

Collapse is a distortion or flattening of wood cells caused by drying stresses inside the board that exceed the compressive strength of the wood or by liquid tension in cell cavities that are filled with water.

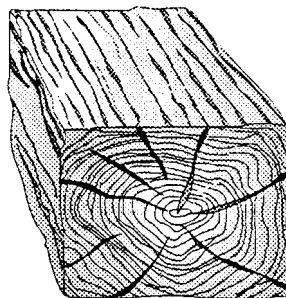
Checks are cracks in or along wood rays on the surface or ends of boards, caused by drying stresses that exceed the tensile strength of the wood perpendicular to the grain.



Honeycombing



Collapse



Checks and splits

Adapted from Simpson, William T. 1991. Dry Kiln Operator's Manual. USDA Forest Service. Ag. Handbook No. 188.

## Self-Testing Questions - Lesson 2

(Some questions may have more than one answer)

1. **Swelling and shrinking of wood is caused by changes in the amount of**  
(a) Free water                      (b) Bound water
2. **Which kind of water evaporates first from green wood cells?**  
(a) Free water                      (b) Bound water
3. **The fiber saturation point occurs:**  
(a) At the air's relative humidity  
(b) When the wood is oven dry  
(c) At the wood's green moisture content  
(d) When free water is absent but bound water remains in the wood cell
4. **Moisture meters can give accurate moisture content readings above the FSP.**  
(a) True                              (b) False
5. **Wood can actually contain more water (by weight) than it contains wood substance.**  
(a) True                              (b) False
6. **Longitudinal shrinkage is normally greater than radial shrinkage.**  
(a) True                              (b) False
7. **Tangential shrinkage is normally greater than radial shrinkage.**  
(a) True                              (b) False
- a. **Honeycomb, collapse and end checks are:**  
(a) Types of warp  
(b) Caused by fungi  
(c) Types of seasoning defects  
(d) Caused by drying wood too fast at too high heat
9. **The types of warp include:**  
(a) Checks                          (b) Cup  
(c) Twist                            (d) Bow  
(e) Crook                            (f) Collapse
10. **Which of these tree species has the highest moisture content in sapwood?**  
(a) Northern red oak  
(b) Western red cedar  
(c) Red pine
11. **Which of these tree species has the lowest heartwood moisture content?**  
(a) Northern white cedar  
(b) Ponderosa pine  
(c) Northern red oak

**NOTE:** Answers are given at the end of the program



# Lesson 3:

## Deterioration of Wood by Fungi, Insects and Marine Borers

### Introduction

Under proper conditions, wood will give centuries of service. But where conditions permit, wood is subject to attack and degradation by fungi, insects and marine borers. These organisms attack wood in a variety of ways: some utilize it for food, some use it for shelter and others for food and shelter.

Lesson 3 helps wood treaters recognize and understand the nature of these wood-attacking organisms in order to properly prescribe treatment and to assure proper performance of their treated products.

### Fungi

Wood degradation is caused by very small organisms called *fungi*. Deadwood conks and mushrooms are visible examples of the fruiting bodies of fungi from which reproductive spores are produced and disseminated. Some fungi merely discolor wood, but wood-rotting fungi can change the physical and chemical properties of wood, thus reducing its strength. Therefore, the many wood-inhabiting fungi can be divided into two major groups, depending on the damage they cause:

- Decay fungi
- Stain fungi (sapstain fungi and molds)

All fungi produce spores (reproductive cells) that are distributed by wind and water. The spores can infect moist wood during storage, processing and use.

All fungi have certain basic requirements:

- Favorable temperatures — usually ranging between 50° and 90°F. The optimum is about 70° to 85° F. Wood is basically safe from decay at temperatures below 35° and above 100°F.

- Adequate moisture — fungi will not attack dry wood (moisture content of 19 percent or less). Decay fungi require a wood moisture content of about 30 percent (the generally accepted fiber saturation point of wood). Thus, air-dried wood, usually with an MC not exceeding 19 percent, and kiln-dried wood, with an MC of 15 percent or less, may be considered safe from fungal damage.
- Adequate oxygen — fungi cannot live without oxygen. That is why saturated or sunken logs do not decay.
- Food source — wood substance (cellulose, hemicellulose, lignin).

### Decay fungi

In most species of wood both the sapwood and heartwood are susceptible to decay. *Decay fungi* grow in the interior of the wood or appear on wood surfaces as fan-shaped patches of fine, threadlike, cottony growths or as rootlike shapes. The color of these growths may range from white through light brown, bright yellow and dark brown. The spore-producing bodies may be mushrooms, shelf-like brackets or structures with a flattened, crust-like appearance. Fine, threadlike fungal strands (called *hyphae*) grow throughout the wood and digest parts of the wood as food. In time, the strength and other properties of the wood are destroyed (See Figure 3.1, page 20).

Decay may be thought of as a reversal of the wood-growing process. You may recall that during growth, the action of sunlight on the leaves of a tree, combined with water and carbon dioxide, forms sugars (mainly glucose). This sugary solution is transmitted to all growing parts of the tree where it is converted chiefly into cellulose, which forms the cell walls. Some of the sugars combine to form *starch* used as a



reserve form of “stabilized glucose” to restart the growth processes when needed, usually in the spring.

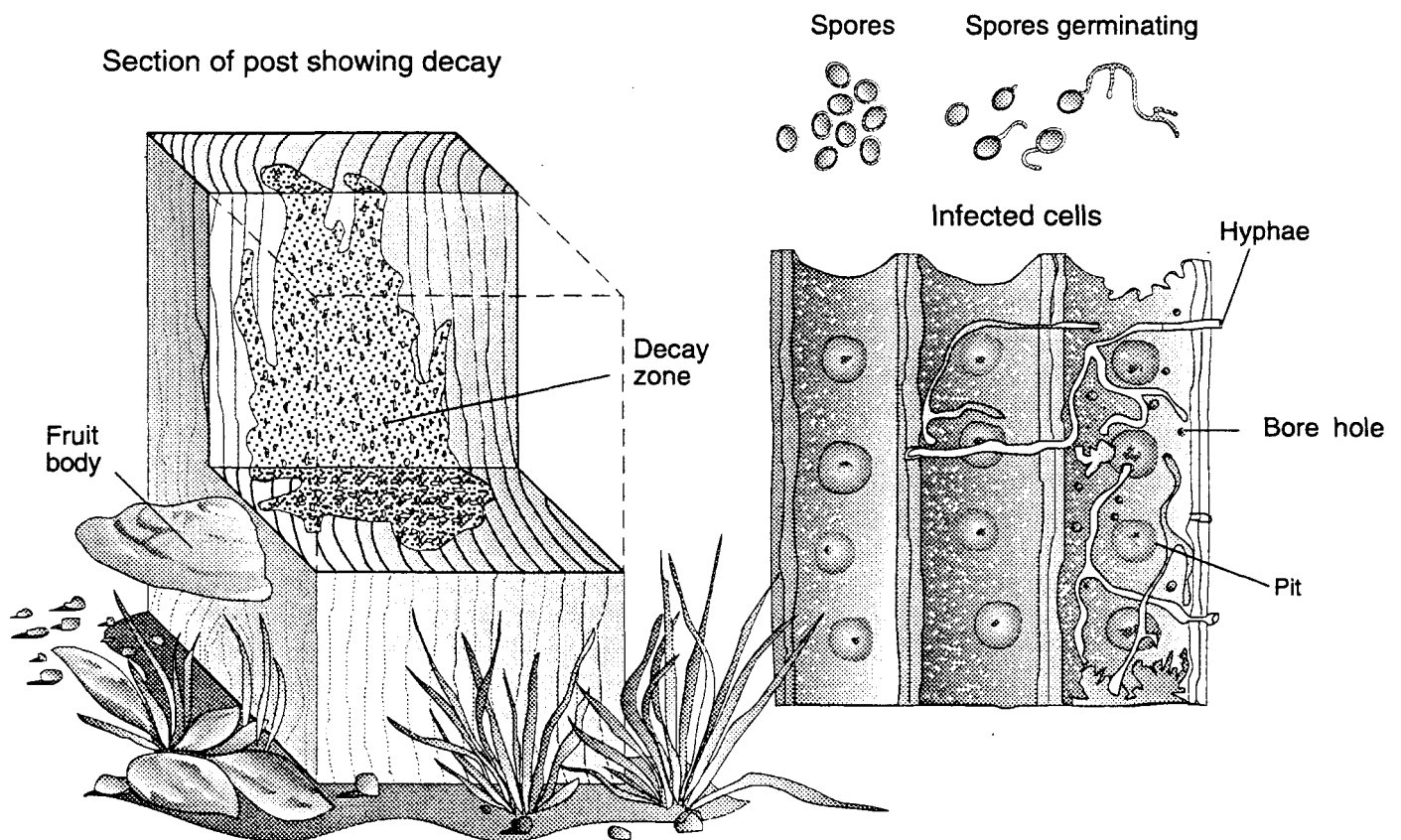
During decay, cellulose and starch are broken down by enzymes into sugars and eventually into carbon dioxide and water. These sugars in wood substance are a source of food that sustains the fungi for further growth and other life processes.

Once decay has started in a piece of wood, the rate and extent of deterioration depend on the duration of favorable conditions for fungal growth. Decay will stop when the temperature of the wood is either too low or too high or when the moisture content is drier than the fungi’s requirements. However, decay can resume when

the temperature and moisture content become favorable again. Early decay is more easily noted on freshly exposed surfaces of unseasoned wood than on wood that has been exposed to and discolored by the weather.

The greatest fungal risk to untreated wooden items comes when they are used in or on the ground. Another risk to unprotected wood is its use in fresh or slightly salty “brackish” water (such as exists near the mouth of rivers), inside water cooling towers and in very humid structures like greenhouses. For many construction uses, wood will be too dry for successful fungal attack.

Wood decay fungi can be grouped into three major categories: brown rot, white rot and soft rot.



**Figure 3.1**

Life cycle of a typical wood-inhabiting fungus: Microscopic airborne spores, produced by fruiting bodies on wood undergoing decay, are carried by winds and air currents to potential hosts—loglumber, wood products, etc. If conditions are suitable, the spores germinate producing filament-like hyphae, which elongate, branch and multiply, spreading through the wood or forming a cottony surface mat or mycelium. Advanced stages of the fungus produce fruiting bodies, often appearing as shelf-like or bract-like conks on wood surfaces. In tiny crevices on the undersides of the conks, myriads of spores are produced which, when mature, are released into the air and carried to the next potential host.



**Brown rot.** Fungi that cause brown rot are primarily able to break down the cellulose component of wood for food, leaving a brown residue of lignin. Wood infested with brown rot can be greatly weakened even before decay is visible. The final stage of wood decay by the brown rots can be identified by:

- The dark brown color of the wood
- Excessive shrinkage
- Cross-grain cracking
- The ease with which the dry wood substance can be crushed to a brown powder

Brown rot fungi are probably the most prevalent cause of decay of softwoods used in above-ground construction in the United States. Brown rot-decayed wood, when dry, is sometimes called “dry rot.” This is a poor term, because fungi must have moisture and will not cause decay when wood is dry. A few fungi that can decay relatively dry wood have water-conducting strands that are able to carry water from damp soil-to wood in lumber piles or buildings. These fungi can decay wood that otherwise would be too dry for decay to occur. They are sometimes called the “dry rot fungi” or “water-conductingfungi.”

**White rot** White rot fungi, which break down both lignin and cellulose, have a bleaching effect that may make the damaged wood appear whiter than normal. Affected wood shows normal shrinkage and usually does not collapse or crack across the grain as with brown rot damage. It loses its strength gradually until it becomes spongy to the touch. White rot fungi usually attack hardwoods, but several species can also cause softwood decay.

**Soft rot** Soft rot fungi usually attack green (water-saturated)wood, causing a gradual and shallow softening from the surface inward that resembles brown rot. The affected wood surface darkens, and this superficial layer, up to 3-4 mm deep, becomes very soft, giving the decay its name.

### *Stain and mold fungi*

**Sapstain fungi.** Sapstain or stain fungi, which live on the starch in wood cells, may

discolor the sapwood entirely or in patches without breaking down the cellular structure of wood. The color of the stain depends on the kind of fungus and the species and moisture content of the wood. Stains may be yellow, orange, purple, red or blue. Most common are the bluestain fungi which turn the wood a bluish or gray-black color. Although blue-stained lumber may experience a reduction in impact strength or shock resistance, other important properties such as compressive and bending strength are not affected. However, it is important to prevent sapstain because it spoils the appearance of lumber, lowers its grade and reduces its commercial value. Sapstain fungi may also provide an environment in the wood that may be conducive to attack by wood-destroying fungi. Sapstain is best prevented by prompt kiln drying or by dipping or spraying with a chemical solution immediately after green wood is sawn. Typical sapstain cannot be removed by planing or brushing.

**Mold fungi.** These fungi first become noticeable as green, yellow, brown or black fuzzy or powdery surface growths on the wood. Discoloration of wood surfaces by molds and mildew is superficial, so the discoloration usually can be removed by brushing or planing. On open-pored hardwoods, however, the surface molds may cause stains too deep to be easily removed. Fresh-cut or even seasoned stock piled during warm, humid weather may be noticeably discolored with mold in less than a week. Molds do not reduce wood strength; however, they can increase the capacity of wood to absorb moisture, thus increasing the potential of attack by decay fungi. Fortunately, molds and mildew growth can be prevented by promptly drying green or moist wood and keeping it dry (below 19 percent MC). Pressure-applied preservatives or other chemical treatments also will effectively prevent their growth.

**Chemical stains.** Chemical stains may resemble blue or brown stains but are not caused by fungi. These stains result from chemical changes in the wood of both soft woods and hardwoods. Staining usually occurs in logs or in lumber during seasoning, and may be confused



with a brown sapstain caused by fungi. The most important chemical stains are brown stains, which can downgrade lumber for some uses. They usually can be prevented by rapid air drying or by using relatively low temperatures during kiln drying.

## **Insects**

Several kinds of insects attack the wood of living trees, logs, lumber and finished wood products. Those attacking lumber and wood products are of particular significance because much of their damage can be prevented with proper wood protection. From an economic standpoint, this group is important because of the cost involved in replacing damaged wooden members. Some insects use wood as a source of food, while others use wood primarily for shelter. Five different groups of insects are discussed:

- Subterranean termites
- Drywood termites
- Wood-boring beetles
- Carpenter ants
- Carpenter bees

### ***Subterranean termites***

Subterranean termites are by far the most destructive insect pests of wood. They are found in all states except Alaska but are most destructive in milder regions of the country. Subterranean termites are social insects that live in colonies located in the ground, with each colony generally consisting of three forms or castes of termites: adults or reproductives, soldiers and workers. The mature workers and soldiers are wingless, greyish white in color, blind, sterile and are similar in appearance. The soldiers, which protect the colony from intrusion, have large heads and heavy jaws that are helpful in their protective duties. Soldiers are approximately 1/4 inch in length. The worker is the colony member that destroys wood by tearing off small wood particles with its heavy jaws. These small particles are ingested and ground into very fine particles in the termite's crop. The ground particles then pass to the rear gut where

enzymes secreted by protozoa reduce the wood cellulose to usable food for termites. The worker is the one generally seen in termite-infested Wood.

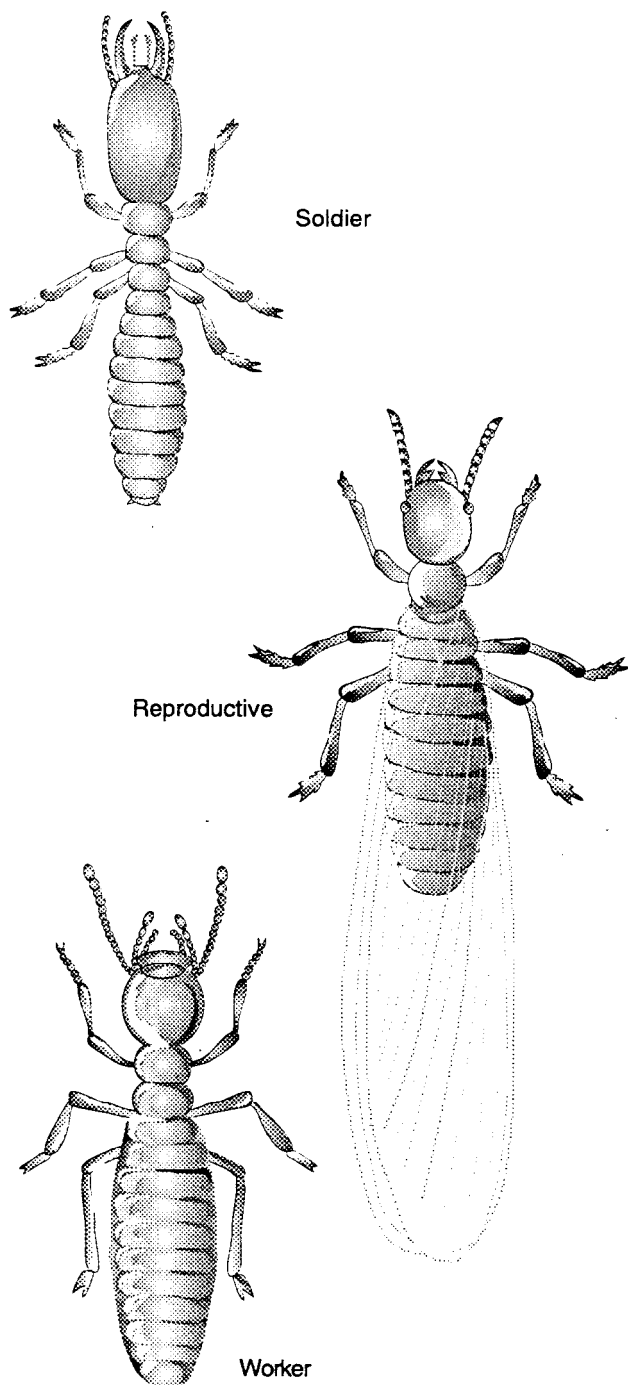
The sexual adults or reproductives are found in colonies that are two years old or older (see Figure 3.2). They have yellow-brown to black bodies, thick waistlines, two pairs of long whitish translucent wings of equal size, and are approximately 1/2 inch in length. Reproductives will generally swarm after the first few warm days of spring, flying to a new location where they shed their wings, mate and start a new colony.

Termite damage is often not noticeable on the attacked wood surface. The exterior surface must be stripped away in order to see the extent of damage. Subterranean termites normally first attack the less dense springwood portion of wood and, when this is depleted, they feed on the denser summerwood.

Although termites require a constant source of moisture to survive, they are able to live in wood containing less than 20 percent moisture by obtaining their moisture from the ground. This moisture is transported by the termites through flattened, earthen shelter tubes that serve as passageways from the soil to the infested wood. These 1/4- to 1/2-inch-wide mud tubes indicate the presence of termites.

Subterranean termites are most numerous in warm, moist soil that contains an abundant supply of food in the form of wood or other cellulose material such as paper, cardboard or cotton. Termites often find these conditions around untreated posts or poles and under buildings where ventilation is poor and where form boards, scraps of lumber, grade stakes, stumps or roots are left in the soil. Most termite infestations in buildings occur because untreated wood touches or is close to the ground, particularly at porches, steps and terraces. Cracks or voids in foundations or concrete floors make it easy for termites to reach wood that is not in close proximity to soil.

Protective measures against subterranean termites include poisoning of the soil around buildings, use of physical barriers on founda-



**Figure 3.2**

A termite colony includes numerous workers that burrow in wood for food and shelter, soldiers that protect the colony from other insects and a single egg-laying queen. Worker termites are sterile, wingless and blind. They are the wood destroyers.

Adapted from Morrell, J. J.; Graham, R. D. and Miller, D. J. 1988. *Safe Use of Preservatives and Preservative-Treated Wood at Home and on the Farm*. Oregon State University.

tions and, primarily, use of properly preserved wood, which makes it undesirable as a food source. However, termites can build their mud shelter tubes across treated wood to reach untreated wood.

### ***Drywood termites***

Drywood termites behave differently from subterranean termites. Drywood termites do not multiply as rapidly as subterranean termites, and have a somewhat different colony life and habits. The total amount of destruction they cause in the United States is much less than that caused by the subterranean termites. However, once a drywood termite enters wood material in a structure or building, it can live its whole life inside the wood, even at moisture contents as low as 5 percent. They can completely hollow out structural or decorative woodwork, which they use both for a food source and a nesting site. Drywood termites are particularly troublesome in southern Florida and southern California, and also occur along the southern gulf coast of the U.S.

### ***Wood-boring beetles***

Beetles that bore into wood cause several types of damage with varying degrees of severity. Sometimes the wood is riddled by holes, sometimes it is so completely pulverized as to be unusable and sometimes the holes or *galleries* and associated stains are the only cause of reduction in a wood's quality or lumber grade. Holes made by wood-boring beetles vary in size, ranging from minute pinholes less than 1/16 inch diameter to holes greater than 1/4 inch diameter. Sometimes the damage is caused by the larvae, which hatch from eggs laid under the bark or in the wood. Two types of wood-boring beetles, *ambrosia* and *powderpost* beetles, are primarily responsible for the majority of boring damage. One type requires green wood, the other dry, seasoned wood.

**Ambrosia beetles.** Ambrosia beetles primarily attack green logs. These insects are economically important because they degrade wood, principally by staining. Ambrosia beetles are unique because they cultivate and feed upon



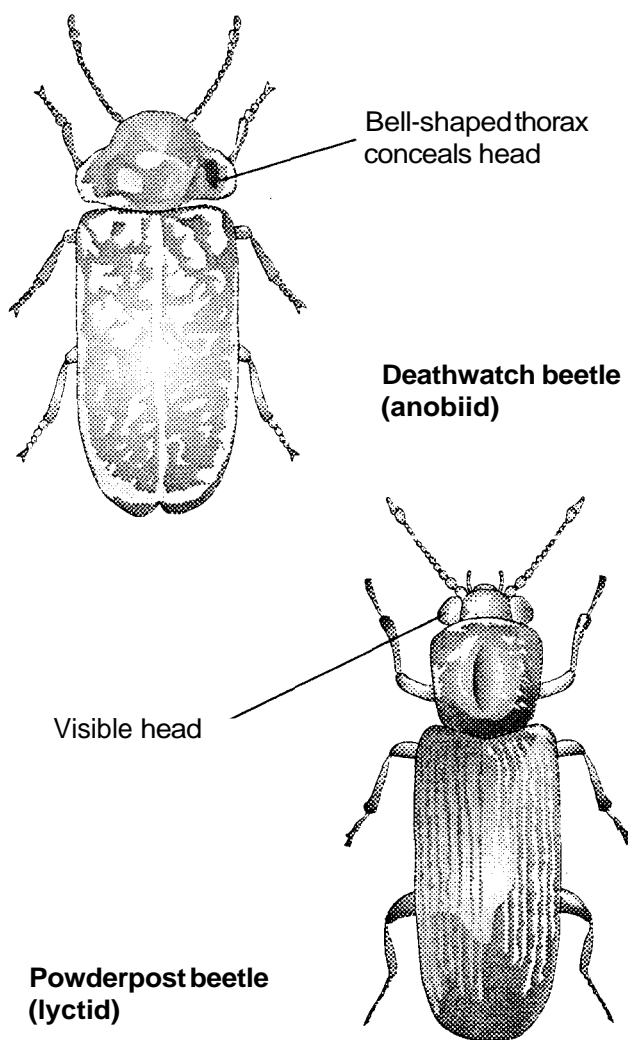
fungi that they introduce into their excavated galleries. They use the wood principally for shelter, deriving no nourishment from the wood itself.

The boring damage to green wood is done by the adult beetles, which bore across the grain of the wood, forming galleries that are kept clear of any boring dust. Accompanying the galleries is extensive staining caused by the implanted fungi. Ambrosia beetle damage generally does not seriously weaken wood structurally, but the associated staining lowers the value of products made from the wood. Ambrosia beetles will attack both hardwoods and softwoods.

**Powderpost beetles.** Second in terms of economic importance among wood-destroying insects are powderpost beetles, which produce the so-called powderpost damage in wood. Powderpost beetles attack both hardwoods and softwoods, both freshly cut and seasoned lumber and timbers, and use the wood for both food and shelter. Within the irregularly-shaped burrows made by the beetles undigested particles of wood in the form of a very fine powder, or *frass*, are left. Hence the name powderpost beetle.

The most important and destructive species of powderpost beetles are Lyctus beetles (see Figure 33). *Lyctids* are small winged insects that lay their elongated eggs in the sapwood pores of certain large-pored hardwoods such as hickory, ash, oak and walnut. The beetle larvae, which develop from the eggs laid by the adult female, tunnel through the sapwood in an irregular pattern, leaving their burrows packed with fine, powdery undigested wood particles. These larvae obtain their food from the starch and reserve food materials stored in the sapwood cells. In early spring, winged adults emerge to mate through small holes 1/32 to 1/16 inch in diameter in the wood surface. The females either fly or crawl to other wood where they deposit their eggs in the large sapwood pores. Following emergence of the winged adults, the fine residue in the burrows falls out of the holes, leaving evidence of the presence of powderpost beetles. Perhaps the most serious aspect of powderpost beetle infestation, and certainly the cause of most concern to homeowners, is the appearance

of emergence holes or “shot holes” in valuable furniture, flooring or paneling. Powderpost beetles will also attack manufactured products such as tool handles, gunstocks, barrels and other products made from the sapwood of susceptible species. Applying a protective coating of paste wax, lacquer or varnish to the



**Figure 3.3**

Powderpost beetles are second only to termites in their destruction of wood. Adult Lyctus beetles range in size from 1/12 in. to 1/15 in. in length, and in color from reddish-brown to black. Exit holes for lyctus beetles are 1/32 to 1/16 in. in diameter. Adult anobiid beetles are 1/10 in. to 1/2 in. in length and reddish brown to grey in color. Exit holes are 1/16 to 1/8 in. in diameter.

*Adapted from Pellitten, Phil. 7990. Wood-Infesting Insects. Fine Homebuilding, April-May. The Taunton Press.*



wood can discourage the female beetles from depositing eggs in the open-pored sapwood.

Powderpost beetles in the family Anobiidae, depending on the species, infest hardwoods and softwoods. *Anobiids'* life cycle takes two to ten years or more and they require a wood moisture content near or above 15 percent for viable infestation. Therefore, in most modern buildings the wood moisture content is generally too low for anobiids. Exit holes for Anobiid powderpost beetles are 1/16 to 1/8 inch in diameter.

**Roundheaded borer.** A longhorn beetle, commonly known as the old house borer, damages seasoned pine timbers (see Figure 3.4). The larvae bore through the wood. Over many years their tunneling can weaken structural timbers, framing members and other wooden parts of buildings. Contrary to its name, the old house borer most often infests new buildings. It is found in the eastern and gulf coast states.

Larvae reduce sapwood to a powdery or sawdust-like consistency. It may take several years to complete their development. While working in the wood, they make a ticking or gnawing sound. When mature, the adult beetle makes an oval emergence hole about 1/4 inch in diameter in the surface of wood.

**Flatheaded borers.** Flatheaded borers are beetles that infest trees as well as recently felled and dead standing softwood trees. They can cause considerable damage in rustic structures and some manufactured products by mining into sapwood and heartwood.

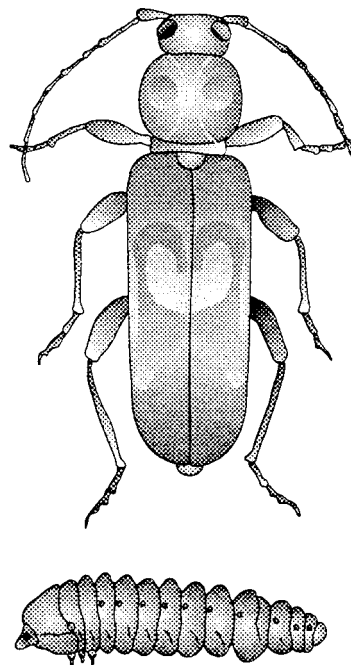
Typical damage consists of rather shallow, long, winding galleries that are packed with fine powder. Exit holes are 1/8 to 1/2 inch in diameter. Adults are often called metallic wood-boring beetles because of their color. They are about 3/4 inch long, with wing covers usually rough, like bark.

#### Carpenter ants

Carpenter ants are the only true ants that are of importance in wood degradation (see Figure 3.5, page 26). Carpenter ants are troublesome particularly in the northeastern and northwestern U.S. They use wood for shelter rather than food, generally attacking the relatively soft spring-

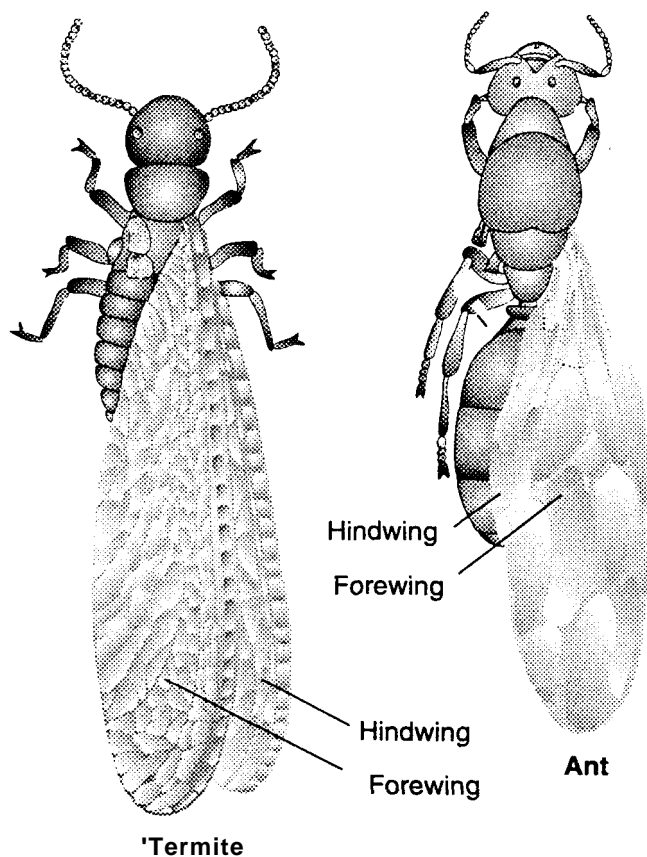
wood first. They can usually be found in old stumps and other wood that has been softened by decay. Carpenter ants are commonly found attacking wood in service such as utility poles and structural members of housing such as porch columns, window sills, sill plates and porch roofs. Although carpenter ants can extend their tunnels into dry wood, they must have high humidity in their nesting area.

Like termites, carpenter ants live in colonies, each colony containing three castes: queens, males and workers. They may gain access to buildings directly from the soil by crawling to wooden members set in or on the ground or they may be carried in on firewood. Damage by carpenter ants can be recognized by the presence of large, hollow, smooth-sided tunnels that cut across the grain of the wood. Generally, the tunnels bored by termites contain frass, whereas the tunnels produced by carpenter ants are clean.



**Figure 3.4**  
**The roundhead borer, also called the old house borer, damages dry softwood lumber.**  
Known for its ticking or gnawing sound, the adult beetle will make a 1/4 in. diameter exit hole.

*Adapted from Preservation and Treatment of Lumber and Wood Products. 1987. New York State College of Agriculture and Life Sciences. Cornell University, Ithaca NY.*



**Figure 3.5**  
**Characteristics that differentiate winged adult ants and termites**

Characteristic	Termite	Ant
Wing size	both pairs of wings of identical size	hindwings much smaller than forewings
Wing veins	very many fine conspicuous veins	few, dark, conspicuous veins
Wing stubs	stubs left when wing detaches	no wing stubs remain when wings break off
Body shape*	no abdominal constriction present	first 1 or 2 abdominal segments constricted to form 'wasp waist'
Antennae*	antennae resemble a string of beads; never "elbowed"	antennae usually "elbowed"; segments not similar in shape

\*These characteristics are also used to separate non-winged forms.

Adapted from Koch, Peter. 1972. *Utilization of the Southern Pines*. USDA Forest Service. Ag. Handbook No. 420.

If left undisturbed for a few years, the black or brown carpenter ants will enlarge their tunnels to the point where wood strength is impaired and replacement or extensive repairs will be required.

### *Carpenter bees*

Carpenter bees resemble large bumblebees, but the top of their abdomen is bare of hairs. Carpenter bees are a problem to unpainted and untreated wood in the eastern and southeastern U.S. These insects cannot digest wood, but they use their jaws to chew holes in which to lay their eggs, and the small pieces of chewed-out wood are discarded. The females make large (1/2 inch diameter) tunnels into soft wood for nests.

Because they reuse nesting sites for many years, the bees' nesting tunnel into a structural timber may be extended several feet and have multiple branches. They will nest in stained wood and wood with thin paint films or light preservative salt treatments as well as in bare wood. Tunnels may be injected with an insecticide labeled for bee control and after several days plugged. A good paint film or pressure preservative treatment usually protects exterior wood surfaces from nesting damage. Because CCA preservatives may not completely protect wood against their damage, suppliers of CCA-treated wood may exclude carpenter bee or carpenter ant damage from warranties they may offer. The best defense against these insects is spraying with a contact insecticide.

### **Marine Borers**

Marine borers are a group of wood-boring marine organisms that attack submerged, unprotected wooden members in salt and brackish waters. Some of these borers may occasionally be found in fresh water. Marine borers attack any untreated wood between the waterline and the mudline. Their boring action plus erosion from wave action generally results in rapid deterioration of wooden structures. There are two distinct groups of marine wood-boring organisms, each characteristic in its general structure and method of attacking wood. One



group is the *molluscan borers*, distantly related to oysters and clams, and the other is the *crustacean borers*, which are kin to lobsters and crabs.

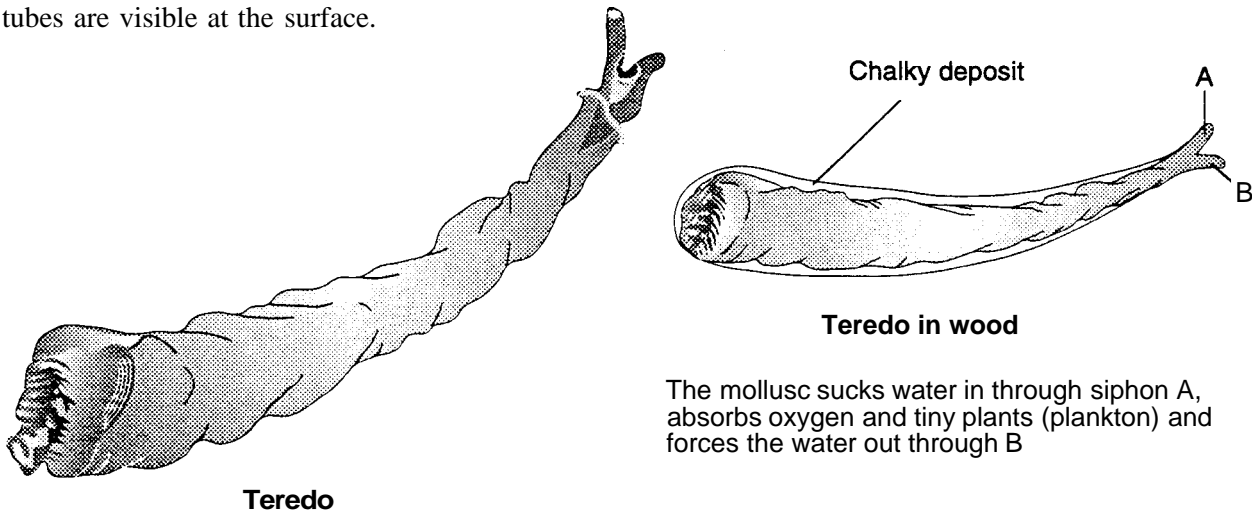
**Molluscan borers**

Molluscan borers consist of three principal genera: *Teredo* spp. and *Bankia* spp., (known collectively as shipworms) and *Martesia* spp or *pholads*. Shipworms are found in nearly all the coastal waters of the United States and Canada. Shipworms enter wood in a tiny worm-like form (see **Figure 3.6**). A pair of boring shells on the head grow rapidly in size as they bore into the wood making larger and longer tunnels which are lined with a chalky, shell-like deposit. The siphon or tail part of the worm remains at the original entrance and their bodies grow behind them within the wood, where they stay confined for life. Their shells rasp the wood, oxygen is extracted from the sea water and enzymes digest the wood, creating ever-larger tunnels. Their tunnels may be up to 3/4 inch in diameter and 2 feet long. In a few months these organisms can do considerable damage to wooden structures and are a constant problem to harbor maintenance engineers because their presence is not readily apparent. Only their protruding siphon tubes are visible at the surface.

Another group of wood-boring mollusks are pholads, which clearly resemble clams and therefore are not included with the shipworms (see Figure 3.7, page 28). These are entirely encased in their double shells. The martesia are the best-known species. Like the shipworms, martesia enter the wood when they are very small, leaving a small entrance hole, and grow larger as they burrow into the wood. They generally do not exceed 2- 1/2 inches in length and 1 inch in diameter, but are capable of doing considerable damage. Their activities in the United States appear to be confined to the Gulf of Mexico and south Florida coastline.

**Crustacean borers**

Crustacean borers, in contrast to shipworms, erode timbers from the outside (see **Figure 3.8** page 28). They are small shelled animals related to shrimp. Both the larvae and adults are mobile and can move from one source of wood to another although they usually continue to bore in one place. By chewing on the surfaces of timbers, large numbers of these marine organism can wear the wood away. The wood surface becomes riddled with tunnels separated by very thin walls which are then broken away by wave



The mollusc sucks water in through siphon A, absorbs oxygen and tiny plants (plankton) and forces the water out through B

**Figure 3.6**  
**Teredo marine borers.** The extremely destructive *Teredo navalis* or shipworm is bisexual: eggs are fertilized within the adult. After hatching, vast numbers of mature larvae are released into the sea. They settle on wood and, after metamorphosis, bore into it. As the adults grow, they deposit a chalky layer on the inside of the tunnel. *Teredo* species are one of three groups or genera of molluscan borers.

Adapted from *Preservation and Treatment of Lumber and Wood Products*. 1987. New York State College of Agriculture and Life Sciences. Cornell University, Ithaca, NY

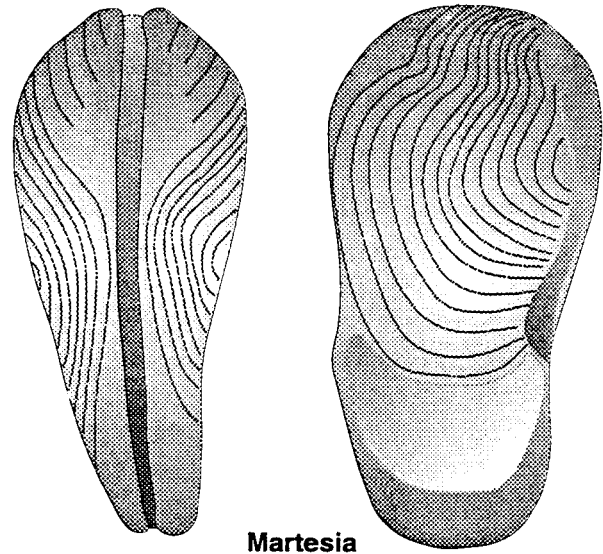


action. Eventually the dimensions of the timbers are reduced so much that they have to be re-placed.

The most common type of crustacean borer is *Limnoria*, which occurs around all U.S. coasts. *Limnoria*, known sometimes as gribbles, are about 1/8 to 1/6 inch long. Untreated piling can be destroyed by *limnoria* within a year in heavily infested harbors. Other species such as *Chelura* and *Sphueromu* are as widely distributed but not as plentiful as *limnoria* and do much less damage.

Apart from heartwood timbers sawn from greenheart trees, (now almost unavailable) only heavily-treated wood of pines are suitable for marine use. Tests in marine waters have shown that creosote offers better protection against pholads than CCA preservatives, while treatment with CCA protects wood better against certain crustaceans. For this reason, where coastal structures must have long lives, and where both wood-boring mollusks and crustaceans are present, it is common to specify CCA treatment followed by reseasoning and then retreatment with creosote. This dual treatment is the best form of chemical preservation presently available, especially where pholads are present.

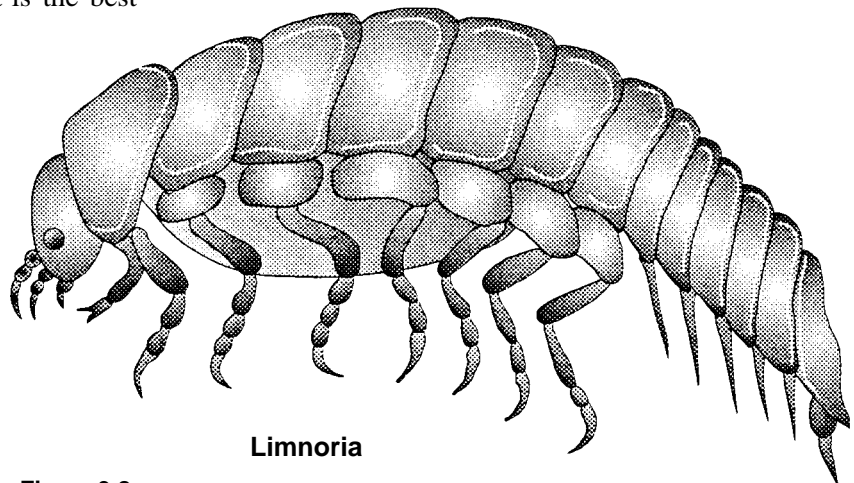
Other methods of preventing attack by marine borers have included wrapping piles with plastic material in an attempt to suffocate the organisms. This can be successful so long as the barrier is not damaged.



**Figure 3.7**

*Martesia* are the most common species of pholads, another group (or genera) of wood-boring mollusks that resemble clams.

Adapted from Preservation and Treatment of Lumber and Wood Products. 1987. New York State College of Agriculture and Life Sciences. Cornell University, Ithaca, NY.



**Figure 3.8**

*Limnoria*, a common type of crustacean borers, are small (1/8 to 1/6 inch long), shelled animals related to shrimp. Crustacean borers, in contrast to shipworms, erode wood from the outside.

Adapted from Koch, Peter. 1972. Utilization of the Southern Pines. USDA Forest Service. Ag. Handbook No. 420. (Drawings after Menzies 1954.)

## Self-Testing Questions - Lesson 3

(Some questions may have more than one answer)

**1. Which gas must be present before wood can be decayed by a fungus?**

- (a) HO
- (b) Nitrogen
- (c) Oxygen
- (d) Carbon dioxide

**2. Wood that is 19 percent MC or less and is stored properly should not decay.**

- (a) True
- (b) False

**3. The optimum temperature range for decay fungi is:**

- (a) 35° to 100° F
- (b) 70° to 85° F
- (c) 55° to 70° F
- (d) None of the above

**4. Decay fungi attack cellulose and lignin whereas stain fungi only live on the starches in wood cells.**

- (a) True
- (b) False

**5. Wood found at the bottom of a lake would not be decayed because:**

- (a) It's too cold
- (b) It's too wet
- (c) There's no food available
- (d) There's not enough oxygen

**6. Carpenter ants make their colonies in the ground and subterranean termites make their colonies in wood.**

- (a) True
- (b) False

**7. Subterranean termites simply live in wood but carpenter ants digest wood for nourishment.**

- (a) True
- (b) False

**8. Exit holes for lyctid powderpost beetles are:**

- (a) 1/32 to 1/16 inches in diameter and filled with wood powder.
- (b) 1/32 to 1/16 inches in diameter and clean.
- (c) 1/8 to 1/4 inches in diameter and clean.
- (d) 1/4 to 3/8 inches in diameter and filled with wood powder.

**9. Which insect leaves round holes in wood, surrounded by dark stains?**

- (a) Lyctus beetles
- (b) Subterranean termites
- (c) Carpenter ants
- (d) Ambrosia beetles

**10. Which two preservatives are used in combination in "double treatments" against marine borers?**

- (a) Pentachlorophenol
- (b) Creosote
- (c) Zinc naphthenate
- (d) CCA

**11. Shipworms are a type of:**

- (a) Molluscan borer
- (b) Crustacean borer
- (c) Limnoria
- (d) Crab

**NOTE:** Answers are given at the end of the program.





# Lesson 4:

## Wood Preservatives

### Introduction

Lesson 4 discusses natural durability and covers the attributes and applications of the major wood preservatives used in the U.S.

### Natural Durability

Some species of wood have natural durability, or resistance to decay and insect damage, which is due to the presence of substances called extractives in the heartwood. Extractives are chemicals that form when the tree is growing, which are harmful to the sensitive cambium. To protect this growth zone, the harmful substances are passed (like transporting liquid toxic waste through pipes) along the rays and deposited in the dead cells of the heartwood. Not surprisingly, extractives are often toxic to insects and fungi as well as to the cambium, so they act like preservatives.

The type and quantity of extractives are characteristic of each wood species, giving it a greater or lesser degree of natural durability, and sometimes a distinctive color and odor of its own.

The heartwood is the only part of some wood species that exhibits high natural decay resistance (see **Table 4.1**, page 32). The sapwood of all known tree species is very susceptible to decay, regardless of any natural resistance of the heartwood. Unless sapwood is entirely removed or impregnated with preservatives, decay is likely to occur even in durable species. Also, some of these very durable species are becoming scarce and costly, as has happened with mahogany and teak. The high cost of these species practically rules out their use solely for high decay hazard situations. Scarcity limits the use of many such species to veneers and small parts so that the wood of each tree will provide optimum raw material utilization and profitability.

There are several reasons why durable species have become scarce.

- Some species, once abundant (for example, American chestnut), have been decimated by the introduction of foreign diseases or insects.
- After harvesting, virgin forestland that once grew durable species has been converted to farmland or replaced with non-durable tree species.
- Naturally durable trees are typically older trees, but the young, fast growing trees that replace the old trees have higher proportions of sapwood-which has no natural durability.
- The world's human population has doubled in just the last 40 years, creating tremendous demands on our forest resources.

The use of naturally durable wood has declined and will continue to diminish. Our future need for durable wood products will be provided by forests replanted with fast-growing trees of low natural durability, but the wood from these trees will be treated with preservative chemicals for use under high-risk decay situations.

### Development of Wood Preservatives

Wood decay has plagued humans since they began building with wood thousands of years ago. When trees with natural durability were available, they were commonly used. But the scarcity of durable timbers in some areas of the world, coupled with a need to make our wood products and structures last longer, led us to develop techniques to preserve wood.

Charring is perhaps the oldest wood preserving technique, first done over 4,000 years ago by plunging round stakes in fire. The Temple of Diana at Ephesus in ancient Greece was built on charred wooden piles. Throughout the centuries, just about every new chemical discovered has



been tried as a wood preservative. The Greeks poured oil into bored holes to preserve the pillars supporting buildings. Vegetable and mineral oils were used to preserve wood by several early peoples, including Romans, Chinese, Burmese, Greeks and Egyptians.

Impregnating wood with chemicals using vacuum and pressure processes started in 1831 with a French invention, making it possible to test thousands of chemicals as preservatives. The testing of new chemical formulations is a never-ending process. Despite this effort, very few new chemicals are suitable for today's wood preserving needs.

*The science of wood preservation could be defined as the process of adding adequate quantities and concentrations of toxic or repellent substances to a given wood product to upgrade its resistance to biological attack and make it highly durable.* All wood preservatives recommended for ground contact use in the U.S. are capable of protecting against wood-destroying organisms, providing the wood cell structure will allow sufficiently deep and uniform penetration into the wood.

**Table 4.1**  
**Heartwood decay resistance of domestic woods**

Resistant or Very Resistant	Moderately Resistant	Slightly or Nonresistant
Bald cypress (old growth) <sup>1</sup>	Bald cypress (young growth) <sup>1</sup>	Alder
Catalpa	Douglas fir	Ashes
Cedars	Honeylocust <sup>3</sup>	Aspens
Cherry, black	Larch, western	Basswood
Chestnut	Oak, swamp chestnut	Beech
Cypress, Arizona	Pine, eastern white <sup>1</sup>	Birches
Junipers	Pine, longleaf <sup>1</sup>	Buckeye <sup>3</sup>
Locust, black <sup>2</sup>	Pine, slash <sup>1</sup>	Butternut
Mesquite	Tamarack	Cottonwood
Mulberry, red <sup>2</sup>		Elms
Oak, bur		Hackberry
Oak, chestnut		Hemlock
Oak, gambel		Hickories
Oak, Oregon white		Magnolia
Oak, post		Maples
Oak, white		Oak (red and black) species <sup>3</sup>
Osage orange <sup>2</sup>		Pines (most other species) <sup>3</sup>
Redwood		Poplar
Sassafras		Spruces
Walnut, black		Sweetgum <sup>3</sup>
Yew, Pacific <sup>2</sup>		Sycamore
		Willows
		Yellow poplar

<sup>1</sup> Southern and eastern pines and bald cypress are now largely second growth with a large proportion of sapwood. Consequently, it is no longer possible to obtain substantial quantities of heartwood lumber in these species for general building purposes.

<sup>2</sup> Exceptionally high decay resistance.

<sup>3</sup> These species or certain species within the groups have higher decay resistance than most woods in this grouping.

Source: Nicholas, Darrel D., 1973. *Wood Deterioration and Its Prevention by Preservative Treatments. Vol. 1 Degradation and Protection of Wood.* Syracuse University Press, Syracuse N.Y.



## Carrier Liquids or Solvents

Preservatives are used in liquid form. They rely on solvents to carry the toxic chemicals into the wood during impregnation. Each wood-preserving chemical has its own unique properties, like solubility and boiling range. In practice, therefore, each is commercially linked to one or more particular solvents that suit the physical properties of the preservative chemical. Table 4.2 shows how carrier liquids (or solvents) are

classified, and which major wood preservative chemicals are used commercially with each carrier.

As the table shows, creosote is unique in acting as both preservative and carrier. This is because creosote is a very complex liquid mixture of chemicals recovered from the heating of coal or wood in the absence of air; only a few of these chemicals are good wood protectors, the others act as carriers or fillers.

Preservative Chemical	Main Liquid Carriers or Solvent				
	Creosote	Heavy Petroleum Oil	Light Petroleum Solvent	Water	Ammonia and Water
Creosotes	X	X			
Pentachlorophenol(PCP)	O	X	X	O*	O
Chromated Copper Arsenate (CCA)				X	
Ammoniacal Copper Arsenate (ACA)					X
Copper Naphthenate		O	O	O*	
Zinc Naphthenate		O	O	O*	
Copper-8-Quinolinolate(Copper-8)				O*	
Bis-(Tri-N-Butyltin) Oxide (TBTO)			O		
BEHAVIOR OF CARRIER AFTER TREATMENT	Little evaporation; most remains in wood permanently	Little evaporation; most remains in wood permanently	Most evaporates from wood	Water evaporates to Equilibrium Moisture Content (EMC)	Water and ammonia evaporates to EMC
<b>Key to table:</b> X = Major use    O = Some use    * = In dispersed or emulsified form					



## Major Chemical Preservatives

The basic properties and uses of the major wood preservatives are discussed in this section and summarized in **Table 43**. Detailed descriptions of their chemical and physical properties are published annually in the American Wood Preservers Association (AWPA) Standards (see references in the appendix).

### Creosotes

Creosotes are brownish-black, oily liquids, with a heavy “smoky” smell. Creosotes and other *tar oils* are produced when a naturally occurring carbon-rich substance (such as coal, lignite or wood) is heated without air. The tars and creosotes vaporize from the hot mass and are recovered by condensation.

Creosotes are probably the oldest commercial wood preservatives. Creosotes are viscous (thick) liquids. At ordinary temperatures, they do not soak into wood enough to preserve it effectively. That disadvantage was rectified in 1838 when John Bethell introduced the *Bethell or full cell process*, which uses pressure to force hot creosote into the wood cells.

The main form of creosote used in North America is *coal tar creosote*, a by-product of the production of coke. Coke is produced from coal and is used in steel manufacturing. Coal tar creosote is always heated before being pressurized into wood. Sometimes it is mixed with other coal distillation by-products such as tar oils or heavy petroleum oils. AWPA standards list the allowed combinations of ingredients.

The success of coal tar creosote since the Bethell process was invented has been phenomenal. All kinds of uses for wood were made possible; even wood species that had little natural durability could be used. Without creosote, it is hard to imagine how North American railroads could have been built. Creosoted crossties, mainly of Douglas fir, southern yellow pine and oak have stabilized tracks for 30 to 50 years. Think, too, of the success of electrification of rural areas and telephone networks, all using creosoted poles; trestle bridges for the nation’s road and rail crossings; and fencing to contain

cattle and other livestock. These developments, extending over half a century, depended on the wood-preserving qualities of coal tar creosote. Sixteen percent of the treated wood products in the U.S. were preserved with creosote in 1990.

Products treated with creosote :  
(also see **Table 4.4**, page 36)

• Railroad crossties	100%	*
• Switch and bridge ties	100%	
• Piling	35%	
• Poles	18%	
• Posts	14%	

\* % of each product’s volume treated with creosote compared to the total volume of this product treated

Creosote is unsuitable for:

- Use inside some buildings where people live or work.
- Most situations where there is contact with people or animals.
- Wood products in contact with or near food.
- Wood surfaces requiring paint.

Permanent weight gain from creosote treatments can be significant. Retentions vary from 5 to 25 pounds per cubic foot (pcf) of wood.

### Pentachlorophenol (PCP or penta)

*Pentachlorophenol* is a crystalline white solid made in a controlled chemical process. The preservative ability of PCP was discovered around 1935, and was developed into a very successful wood preservative.

Pentachlorophenol is usually dissolved in either light or heavy petroleum oil to produce wood-preserving liquids. It can also be dissolved in water (as ammonium pentachlorophenate) and can be dispersed or emulsified using water as its carrier. Penta can also be added to creosote and petroleum oil mixtures to boost performance.

Penta treating solutions impregnated into wood have a tendency to evaporate, causing blooming (See Table 43). Blooming is the formation of crystals on the surfaces of treated wood as a result of exudation and evaporation of the solvent.



**Table 4.3**  
**Summary of advantages, disadvantages and properties of the restricted-use pesticides creosote, pentachlorophenol and inorganic arsenicals.**

Pesticide	Advantages	Disadvantages
Creosote	<ol style="list-style-type: none"><li>1. Excellent protection against fungi, insects and most marine borers.</li><li>2. Insoluble in water.</li><li>3. Excellent stability, suitable for thermal and Boultonizing processes.</li><li>4. Provides excellent water repellency and mechanical stability.</li></ol>	<ol style="list-style-type: none"><li>1. Poor protection against certain marine borers.</li><li>2. Leaves dark, oily, unpaintable surface.</li><li>3. Tendency to bleed or exude from wood surface.</li><li>4. Strong odor—cannot be used in homes or other living areas because of toxic fumes. Harmful to plants.</li><li>5. Contact with treated wood may cause skin irritation or burns.</li><li>6. Heating is required to reduce viscosity.</li><li>7. Can ignite, so it must be heated cautiously.</li><li>8. Treated wood remains considerably heavier: 25-50% weight increases are common.</li></ol>
Pentachlorophenol	<ol style="list-style-type: none"><li>1. Excellent protection against fungi and insects.</li><li>2. Can be dissolved in oils having a wide range of viscosity, vapor pressure and color.</li><li>3. Can be glued or painted depending on carrier.</li><li>4. Water repellents can be added to improve weatherability.</li><li>5. Good heat stability—but heating Penta is not common.</li><li>6. Low weight increase (1-2%) if an evaporating carrier is used.</li></ol>	<ol style="list-style-type: none"><li>1. Poor protection from marine borers.</li><li>2. Can leave oily, unpaintable surface, depending on carrier used.</li><li>3. Irritating smell, toxic to plants, animals and people.</li><li>4. Not suitable for use in homes or other living areas.</li><li>5. Contact with treated wood may cause skin burns or irritation.</li><li>6. All oil carriers are flammable.</li><li>7. Permanent weight increases of 20-50% if heavy oils are used.</li><li>8. Tendency to “bloom” (p. 34)</li></ol>
Inorganic arsenicals	<ol style="list-style-type: none"><li>1. Excellent protection against fungi insects and most marine borers.</li><li>2. Produces no smell or vapors.</li><li>3. Suitable for use indoors.</li><li>4. Non-toxic to nearby growing plants.</li><li>5. Treated surfaces can be painted.</li><li>6. Permanent weight increases of only 1-2% after wood has reseasoned.</li></ol>	<ol style="list-style-type: none"><li>1. Only moderate protection from pholad marine borers. Will not prevent mildew.</li><li>2. Does not protect wood from excessive weathering.</li><li>3. Not heat stable above 140° F; therefore cannot be used in thermal or Boultonizing process.</li><li>4. Temporary weight increases of 20-90% immediately after treatment. Swells wood when treated, so some seasoning defects may occur when redried.</li></ol>



This evaporation is minimized by the inclusion of a nonvolatile liquid in those preservative solutions using an evaporating carrier or solvent. Protection from contact with penta crystals can be accomplished by sealing the dried, treated surfaces with a coating of urethane, shellac, varnish or a latex epoxy enamel.

Note: *Sodium pentachlorophenate*, the water-soluble form of pentachlorophenol, and the closely-related *tetrachlorophenol*, were once widely used in anti-sapstain dips for treating lumber in sawmills. This treatment and other anti-sapstain chemicals are not covered in this program. Eight percent of the treated wood products in the U.S. were preserved with penta in 1990.

**Table 4.4** - Production of treated wood in the United States, by product, 1990<sup>1,5</sup>

Products	Volume Treated With					
	Creosote Solutions <sup>2</sup>	Oilborne Preservatives <sup>3</sup>	Waterborne Preservatives <sup>4</sup>	Fire Retardants	All Chemicals	
	1,000 Cubic Feet					
	1990	1989			1990	1989
Crossties	62,988	—	—	—	62,988	58,022
Switch & bridge ties	7,165	—	—	—	7,165	6,301
Poles	13,251	42,821	17,429	—	73,501	73,975
Crossarms	5	1,237	165	—	1,407	1,881
Piling	2,494	6	4,686	—	7,186	9,678
Fence posts	2,131	252	12,491	—	14,874	14,377
Lumber	2,595	721	319,853	4,409	327,578	306,577
Timbers	965	545	46,491	—	48,001	43,951
Plywood	—	48	9,317	2,908	12,273	13,189
Other products	1,598	964	27,244	859	30,665	28,992
All Products	93,193	46,592	437,675	8,176	585,635	556,943
	-1989 89,870	49,386	406,941	10,746	556,943	

1 Estimate based on reported production of 431 treating plants plus estimated production of 109 nonreporting plants. 1989 data added for comparison.

2 Creosote, creosote/coal tar and creosote/petroleum.

3 Pentachlorophenol, copper naphthenate, zinc naphthenate, copper-8-quinolinolate and TBTO (97+ percent pentachlorophenol).

4 Inorganic arsenicals CCA, ACZA and CZC (98+ percent CCA).

Source: Micklewright, James T. 1992. *Wood Preservation Statistics, 1990*. American Wood Preservers Association.



Products treated with pentachlorophenol:  
(also see Table 4.4, page 36)

- Poles 50% \*
- Crossarms for utility poles 88%
- Posts 2%
- Timbers 1%

\* % of each product's volume treated with penta in comparison to the total volume of this product treated

PCP is unsuitable for:

- Most uses inside homes or offices.
- Marine protection of wood.
- Uses where livestock can come in contact with it.
- Wood products in contact with or near food.

### ***Inorganic arsenicals***

#### ***(waterborne preservatives)***

The inorganic arsenicals (also called the waterborne preservatives) are a group of preservatives that include chromated copper arsenate (CCA), ammoniacal copper arsenate (ACA), ammoniacal copper zinc arsenate (ACZA), chromated zinc chloride (CZC) and acid copper chromate (ACC).

CCA is by far the most widely-used preservative in the U.S. (98% of the wood products treated with waterborne preservatives were treated with CCA). In fact, almost 75% of all treated wood products were preserved with CCA in 1990.

Products treated with waterborne preservatives: (Also see Table 4.4, page 36).

- Lumber 98% \*
- Timber 97%
- Poles 24%
- Post 84%
- Plywood 76%
- Piling 65%
- Other Products 89%
- Crossarms 12%

\* % of this product's volume treated with waterborne preservatives compared to the total volume of this product treated

#### **Chromated copper arsenate (CCA).**

Copper was known to have preservative properties long before the development and use of CCA. Copper sulfate in water solution is a fairly

inexpensive wood preservative, but two factors prevent its widespread use:

1. It is very soluble in water, so it tends to wash or leach out of the treated wood, leaving the wood unprotected.
2. Copper sulfate protects wood from most fungi, but is ineffective against insects such as termites and a few "copper-tolerant" fungi.

The first problem (solubility) was overcome by adding chromates to copper sulfate to "fix" the copper in the wood in an insoluble form. The second fault was corrected by including arsenates with the copper/chromate mix to control both insects and copper-tolerant fungi (See **Table 4.3** page 35).

International commercial use of CCA preservatives began in the 1950s. They are marketed under several brand names and have become the most versatile of all wood preservatives. Their use is growing in North America, partly at the expense of creosote and pentachlorophenol. Also, more and more treated lumber is being demanded by specifiers and the do-it-yourself market, which usually has limited uses for creosote or penta preservatives.

The weight of wood may double after CCA treatment, but most of the additional weight is water, which evaporates after redrying. The permanent weight of CCA oxides is small, ranging from 0.7 % to 1.8 %, because only 0.25 lb/cu. ft. is required for above-ground use and 0.40 lb/cu. ft. is required for ground-contact use.

As with most preservatives, wood properly treated with CCA shows no significant changes in strength. However, long-duration use of high temperature and/or high pressure during treatment can lower wood strength.

Treatment with CCA initially imparts an orange hue to the wood, then changes to pale green. Other colors may be obtained using color additives before, during or after treatment.

CCA is unsuitable for:

- Wood products in contact with food.
- Preserving railroad crossties. Creosotes and PCP in heavy petroleum oil offer crossties more protection against cracking in wet/dry weather cycles.



AWPA standards list three types of CCA which may be used interchangeably throughout the commodity specifications covered. These are CCA types A, B and C, and their differences arise from historical rather than scientific or practical grounds. At present, type C is most widely used. Details of the three types are:

	A	B	C
	(nominal percent)		
Copper oxide,	18.1	19.6	18.5
Chromium trioxide	65.5	35.3	47.5
Arsenic pentoxide	16.4	45.1	34.0
<b>Total</b>	<b>100.0</b>	<b>100.0</b>	<b>100.0</b>

*Note that the copper content of the three types of CCA is similar. The differences lie in the balance between chromium and arsenic.*

**Ammoniacal copper arsenate (ACA) and ammoniacal copper zinc arsenate (ACZA).** These preservatives are similar to CCA, but do not use chromate as a fixing agent. Instead, copper arsenate is made soluble in water mainly by addition of ammonia. After treatment the ammonia and water evaporate, leaving water-insoluble copper arsenate “fixed” in the wood. Treated wood has an uneven blue/green to brown color.

The ACA preservative (commercially known as *Chemonte*) was developed on the west coast of U.S., and is mainly used there and in western Canada for pole treatments. Pound for pound it is usually rated equal in performance to CCA.

#### **Other preservatives**

There are a number of wood preservatives available, but never assume they all are equally effective. In specifying treated wood for a given purpose, refer to the AWPA standards or federal specifications for acceptable preservatives and treatments.

**Copper Naphthenate (oilborne).** Copper naphthenate is made by reacting copper salts with naphthenic acid (a petroleum by-product). It is a viscous, dark blue-green liquid, soluble in petroleum solvents and should contain 6–8% copper by weight. It can be produced in a form

emulsifiable in water, but is normally dissolved in heavy or light petroleum.

The product is a good wood preservative for preventing decay, and is suitable for ground contact. It’s also safe to use near growing plants (after any volatile solvent used has evaporated). Treated wood has a distinctive green color, but this fades in sunlight. It is used for greenhouse lumber, yard and landscape timbers and seed and mushroom boxes.

Disadvantages are its fairly high cost, lack of protection against termites, persistent “oily” smell and poor ability to take paint or glue. Organic solvent versions are flammable.

**Zinc naphthenate (volatile petroleum oilborne).** Zinc naphthenate is similar to copper naphthenate but is not as effective a fungicide. It should only be used for above-ground products. The zinc salt does have the advantage of being almost colorless.

**Copper-8-quinolinolate (water and volatile petroleum oilborne).** Copper-8 (for short) is the only preservative accepted in the U.S. for wood in direct contact with human food. Preservative solutions must be made using a well-refined “odorless” solvent to avoid tainting food. It is normal to add an equal weight of nickel 2-ethylhexoate to the copper-8. The concentrated preservative chemical should contain 1.8% by weight of both copper and nickel.

Copper-8 is quite expensive, but this may be justified for its specialized uses such as for food pallets, wooden vehicle and container bases and in food processing equipment. The liquid is bluish-green and is flammable. It is not suitable for ground contact.

**Tributyltin oxide (volatile petroleum oilborne).** TBTO is a colorless, watery liquid with a sharp, retentive odor. The tin content, by weight, should be between 38.2% and 40.1 %.

This liquid is dissolved in light petroleum solvents and is flammable. It is mainly used in place of pentachlorophenol at concentrations of 0.5 to 1.5% TBTO, where improved paint or glue performance is needed. It is limited to above-ground use such as for millwork and especially for window and door components.



## Preventing Destruction by Fire and Weathering

Each of the wood preservative chemicals discussed are able to prevent some, or all types of biological degradation of wood. They either interfere with the enzymes promoting decay or are toxic to insect pests.

Biological decay equation:



Deterioration of wood by fire and weathering (physical causes) has the same ultimate effect as decay of wood by fungi. The only difference between the biological and physical deterioration processes is the source of energy used. Enzymes trigger the biological (fungal) decay. Physical deterioration from fire relies on heat. The energy for weathering comes from light, wind, rain, frost and heat.

Physical deterioration equation:



### Fire retardant treatments

Neither wood nor any other construction material can withstand prolonged, intense heat without being broken down and eventually destroyed. Nevertheless, we try to minimize structural failure to safeguard life and property. Chemical protection of wood from damage by fire is accomplished with *fire retardant treatments* (FRT). Fire retardant formulations are used to change the behavior of wood in a fire. Certain chemicals, especially *ammonium salts*, *borates*, *phosphates*, *bromides* and *antimony oxides* can help to prevent or reduce ignition of wood and flaming of wood surfaces.

Fire retardant chemicals also help to increase charring. *Char*, a porous, low-density form of black carbon, is an excellent thermal insulator. If the outer 1/2" of wood in a heavy beam can be converted to char, the undamaged wood underneath will probably keep its strength in a fire lasting an hour or more. Such maintenance of a

beam's strength can help safeguard occupants from sudden structural collapse.

These chemicals also reduce smoke production and prevent flames from starting. Fire retardants may not save the wood in its original form, but they can certainly save people and property by delaying the spread of fire. Firefighters also benefit from FRT wood materials because they generally have a smaller fire to deal with.

### Water-repellent finishes

Wood exposed to the weather is adversely affected by the sun's heat and ultraviolet rays, rain, ice, wind and dust. Birds may peck holes in outdoor wood, and fiber-using insects (for example, wasps) may remove the surface fibers to build "paper" nests.

Despite this awesome list of weathering factors, outdoor wood can be protected by coating exposed surfaces with one or two coats of a pigmented, water-repellent finish usually containing *waxes* and *resins*. Waxes and resins stabilize the surface fibers, prevent wetting by rain and hold pigments on the wood surface. Pigments give color and absorb heat and harmful ultraviolet rays that otherwise would bleach the wood of its natural color and accelerate breakdown of the surface layers.

Water-repellent treatments are not defined in the AWPA standards, but several good proprietary brands of transparent wood finishes are available in home improvement and paint stores. If applied in one or more coats, these finishes do not form a discrete film on the wood surface as paints or varnishes do. Therefore, they are not likely to peel or flake, and are more easily maintained over the years.

### Health and Safety Factors

In the late 1970s, the Environmental Protection Agency (EPA) studied the three major groups of wood preservatives in terms of their risks to the environment, to treaters and to users of the treated wood. This study covered creosotes, pentachlorophenol-based preservatives and waterborne or arsenical preservatives.



The EPA's study determined that all three classes of preservatives could damage the health of people, plants and animals in contact with the preservatives or in close proximity to a treating plant. The first significant document issued was called a *Rebuttable Presumption Against Registration*, or *RPAR*, issued in 1978. Nearly six years of study, discussion and lobbying followed; before the EPA published its findings about the three types of preservatives in its *Position Document #4* or *PD-4*, issued in July 1984.

PD-4 concluded that:

1. Each class of preservative studied is capable of adversely affecting the health of people producing or using the treated wood and other people indirectly by vapors from treating plants or by contaminated groundwater, etc.

2. Each preservative plays a significant part in conserving the U.S. timber resources by preventing early decay of wood in homes and other buildings, fencing, poles and crossties, thereby greatly benefiting the nation.

3. Ways could be found to allow the continued use of all three types of preservatives but tighter restrictions on handling, labeling and treatment site practices would be needed. The industry was also required to develop a Consumer Awareness Program (CAP) and to provide *Consumer Information Sheets (CISs)* with all sales or deliveries of treated wood. This requirement later became a voluntary request.

After further discussion between the EPA and the wood-preserving industry, a detailed agreement was reached. This covered changes in practices to protect the treater, the end user and the environment. (Detailed safety and environmental regulations encompassing these changes are discussed in Lesson 8.)

## Self-Testing Questions - Lesson 4

(Some questions may have more than one answer)

**1. Which of these tree species has sapwood that is resistant to decay?**

- (a) Red oak
- (b) Western red cedar
- (c) Redwood
- (d) Red pine
- (e) None of the above

**2. Which properties of a wood species can be attributed to “extractives”?**

- (a) Color
- (b) Natural durability
- (c) Strength
- (d) Smell

**3. Which carrier liquids evaporate more or less completely after treatment?**

- (a) Heavy petroleum oil
- (b) Light petroleum oil
- (c) Water/ammonia
- (d) Creosote
- (e) Water

**4. The most common carrier(s) or solvent(s) for CCA is:**

- (a) Coal tar creosote
- (b) Water
- (c) Light petroleum solvent
- (d) Mineral spirits

**5. Which of these chemical preservatives are sometimes added to creosote?**

- (a) Copper-8
- (b) ACA
- (c) PCP
- (d) Copper naphthenate

**6. Crossties are predominantly treated with which preservative?**

- (a) Penta
- (b) Copper naphthenate
- (c) CCA
- (d) Creosote

**7. Utility pole crossarms are predominantly treated with which preservative?**

- (a) Copper naphthenate
- (b) Penta
- (c) ACA
- (d) Creosote

**8. How many types of CCA are listed in the AWPA standards?**

- (a) Two
- (b) Five
- (c) Four
- (d) Three

**9. Which preservatives are not suitable for treating lumber for use inside a home?**

- (a) Creosote
- (b) PCP
- (c) CCA

**10. If a colorless preservative is needed, which of these chemicals could be considered?**

- (a) Zinc naphthenate
- (b) CCA
- (c) PCP
- (d) TBTO
- (e) Creosote
- (f) ACA

**11. Which preservatives are not suitable for greenhouse construction?**

- (a) CCA
- (b) ACA
- (c) PCP
- (d) Creosote
- (e) Copper naphthenate

**12. Which preservative(s) are best suited for decks and landscape timbers?**

- (a) Creosote
- (b) ACA
- (c) Penta
- (d) CCA
- (e) Copper naphthenate

**13. Which preservative(s) have little or no irritating odors?**

- (a) CCA
- (b) Penta
- (c) Creosote
- (d) Copper-8

**NOTE:** Answers are given at the end of the program.





# Lesson 5:

## Preservative Treating Processes

### Introduction

Lessons 1 and 2 described tree growth, wood structure and the relationships between wood and water. That information will now seem more pertinent as we consider how wood cells behave if we try to force a preservative liquid into them. Lesson 5 discusses the factors affecting the permeability of wood, and describes the various processes used to treat wood products.

### Flow of Liquids Into Wood

There are great differences in permeability to preservatives among individual species of softwoods and hardwoods. Some cells allow liquids to pass through them easily and into other cells and some do not. Several factors determine how permeable a particular piece of wood is:

- Types of cells
- Amount of ray cells
- Types, size and number of pits
- Presence of extractives

Two other factors affecting a wood's permeability must also be understood:

1 Whatever the shape or size of wood to be treated, preservatives can only get in from the outside. So the permeability of the outer cells is critical—if they refuse to accept preservative, none can possibly penetrate to cells inside the wood.

2. In wood that is green (high moisture content) nearly all the cells are full or partially full of free water and the cell walls will also be saturated with bound water. Preservatives cannot be forced into such wood, so penetration and absorption will be negligible.

softwoods

Look at the softwood cube illustrated in **Figure 5.1a**, page 44. This is a greatly enlarged model of a tiny piece of dry softwood. What would happen if a real wood cube was dipped in a light petroleum oil carrier?

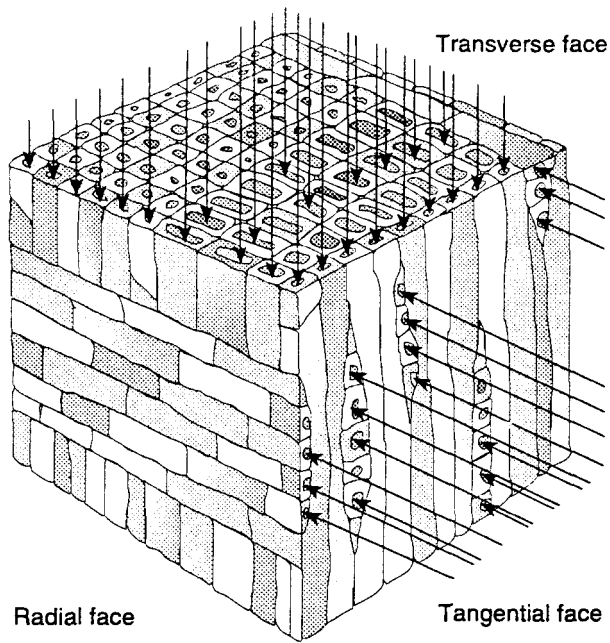
As **Figure 5.1a** shows, the liquid would mainly enter four of the six faces of the cube, that is, the two cross-sectional or transverse faces and the two tangential faces. The two radial faces, which have no exposed open-ends of cells, will be relatively unimportant in absorbing liquids.

The *cross-sectional faces* expose end-grain or open tracheid cells to the oil. These tracheids, acting as hollow tubes, will accept liquid easily. Their small diameter actually encourages “sucking-in” of the liquid by capillary action, like blotting paper or a sponge. Oil will pass through the pits in the cell walls into adjoining tracheids.

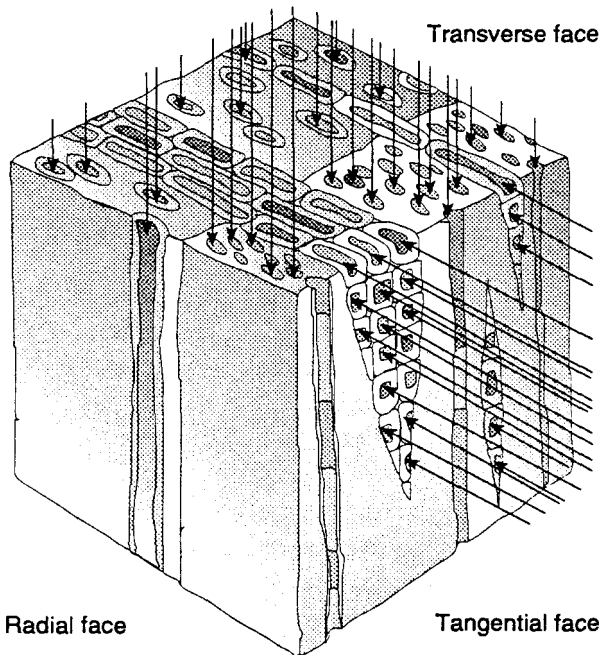
The two *tangential faces* expose open ends of ray tracheid cells to the oil. The rays are also capable of capillary absorption of liquids, so they accept and transport the oil in a radial direction.

Within seconds of immersion in oil, the tiny softwood block will have absorbed perhaps enough oil to fill three-fourths of its cell cavities. How can this happen? What happened to the air that was in the block?

First, the *capillary force* is so strong it causes the air to squeeze up, or compress, in the cells. This allows space for the liquid oil. Second, some compressed air will escape through wider cells having less capillary pressure and will bubble out of the wood surfaces to make room for more liquid. Thus, the tiny softwood block will absorb a good proportion of its void volume in seconds, and most of the cells will receive some oil.



**Figure 5.1a**  
In softwoods most preservative flow occurs by means of the vertical fiber tracheids and the horizontal ray tracheids. As these make up virtually all the wood volume, it is possible to fully saturate some softwoods with preservative.



**Figure 5.1b**  
In hardwoods only the vessels and the ray tracheids can conduct preservatives. This often leaves extensive regions of fibers unprotected. As these give hardwoods much of their strength, this can be a very serious situation.

If preservation of this small cube of wood had been our objective and if the oil had contained a good wood preservative chemical, we could confidently say that the softwood cube had been well-preserved.

### Hardwoods

Now let's see what happens when we repeat the same experiment with a hardwood cube (See **Figure 5.1b**). First, note the similarities between hardwoods and softwoods. Capillary action will suck oil into the open-ended cells of the two cross-sectional faces and the ray cells of the two tangential faces. Again, little oil will enter the radial faces.

Now note the differences from the softwood experiment. The cell ends of hardwoods, exposed by cutting the transverse faces, are of two types: vessels and fibers. *Vessel segments*, with large diameter cavities are joined end-to-end with other vessel segments to form long tubes (the vessels). In most hardwoods, oil will easily enter these vessels, and trapped air can bubble out from the wide cavities, allowing the vessels to fill with oil.

*Fibers* respond differently, however. If you recall, they are narrow sealed cells that play no part in sap movement in the living tree. The fibers, exposed by the transverse sections, can readily accept oil by capillary suction, but they cannot easily pass it on to the other fibers. Consequently these fibers will not normally receive oil from the transverse sections.

As with softwoods, the hardwood ray cells are like open networks of tubing, able to absorb oil easily. The rays in most hardwoods are wider than those in softwoods, so a greater uptake of oil may occur in the rays. Also, the rays can pass some oil to adjoining fibers, although the majority of fibers could remain dry.

Although quite a lot of oil may have been absorbed by the hardwood cubes, mainly in the vessels and ray cells, significant internal areas of the block (fiber areas) may have little or no oil. From a preservation standpoint,



there is a lot of unprotected cellulose and lignin in these fibers that is liable to decay. What is worse, as Lesson 1 pointed out, the principal strength of hardwoods comes from these unprotected fibers.

The explanations of how liquid oil is taken up by these small softwood and hardwood cubes are also applicable to treating full-sized wood products. For example:

- Even if pressure is not used in a wood-preserving process, capillary suction creates a negative pressure or partial vacuum because of the narrow diameter of wood cell cavities, so some liquid chemicals will be absorbed.
- Air in wood cells can be compressed easily.
- Air (compressed or not) is an obstacle to full impregnation of wood with liquids.
- Rays and vessels in hardwoods and the fiber tracheids and rays in softwoods are the main routes for liquid flow into wood.
- Fibers in hardwoods can act as a tight, impenetrable mass, which is difficult or impossible to treat with a preservative, depending on the species of wood. **Table 5.1**, page 46, lists the penetrability of various softwood and hardwood species.

## Methods of Applying Preservatives

Let's discuss treating methods using a round fencepost of an easily-penetrated softwood species as an example of a wood product being treated with a selected preservative.

### *Brush-on and spraying*

The simplest treating methods do not involve expensive equipment. We could brush or spray a post on all surfaces, expecting capillary action to give the preservative penetration into the wood. After several good brush coats, or sprayings and some obvious sucking-in of preservative, we would probably find that further absorption was negligible.

Additional applications would result in wet wood surfaces and there would be considerable run-off. If we sliced the post end-to-end, penetration by the preservative might resemble something like **Figure 5.2a**, page 47. The deepest penetration is at the ends (transverse or cross-sections, where tracheid ends were exposed to the preservative liquid). Radial penetration into the post surfaces is shallow; the rays are largely responsible for the absorption seen in this direction.

Note that all of the heartwood and much of the sapwood is left unpreserved by the brushing or spraying method. When the post is part of a fence, the ground line is where the combination of air, moisture, wood and fungal source meet, and it is in this area that the risk of decay is greatest (see Lesson 3). Even a shallow split in the post will expose untreated sapwood, and allow decay to start.

Brushing and spraying are not good treating methods for preserving wood exposed to high risk of decay, such as for ground contact uses.

### *Cold soaking or steeping*

The term *cold soaking* is used when an unheated oil solution of preservative, such as penta or copper naphthenate, is used. The term *steeping* is used for treatments of wood by preservatives in a water solution. The process consists of partially filling an open tank with preservative and immersing a dry, round fencepost in the tank. The post floats, so it must be weighted down to keep it submerged. The post is soaked for 24 or more hours, then removed. If we cut it lengthwise as before, the pattern of penetration using this treating method may look like **Figure 5.2b**, page 47. Note that both end-grain penetration and radial penetration are better than that obtained by brushing. Cold soaking or steeping has three advantages over brushing or spraying:

1. It allows a longer time for absorption to occur.



**Table 5.1**  
**Classification of American woods with respect to heartwood penetrability.**

Softwoods

Hardwoods

**Group 1. Heartwood Easily Penetrated**

Bristlecone pine, *Pinus aristata*  
 Pinon, *Pinus edulis*  
 Ponderosa pine, *Pinus ponderosa*

Basswood, *Tilia americana*  
 Beech (white heartwood), *Fagus grandifolia*  
 Black gum, *Nyssa sylvatica*  
 Green ash, *Fraxinum pennsylvanica lanceolata*  
 Pin cherry, *Prunus pennsylvanica*  
 River birch, *Betula nigra*  
 Red oaks, *Quercus spp.*  
 Slippery elm, *Ulmus fulva*  
 Sweet birch, *Betula lenta*  
 Tupelo gum, *Nyssa aquatica*  
 White ash, *Fraxinus americana*

**Group 2. Heartwood Moderately Difficult to Penetrate**

Douglas fir (Pacific-coast type), *Pseudotsuga taxifolia*  
 Jack pine, *Pinus banksiana*  
 Loblolly pine, *Pinus taeda*  
 Longleaf pine, *Pinus palustris*  
 Norway pine, *Pinus resinosa*  
 Shortleaf pine, *Pinus echinata*  
 Western hemlock, *Tsuga heterophylla*

Black willow, *Salix nigra*  
 Chestnut oak, *Quercus montana*  
 Cottonwood, *Populus spp.*  
 Big-tooth aspen, *Populus grandidentata*  
 Mockernut hickory, *Carya tomentosa*  
 Silver maple, *Acer saccharinum*  
 Sugar maple, *Acer saccharum*  
 Yellow birch, *Betula alleghaniensis*

**Group 3. Heartwood Difficult to Penetrate**

Eastern hemlock, *Tsuga canadensis*  
 Engelmann spruce, *Picea engelmannii*  
 Lowland white fir, *Abies grandis*  
 Lodgepole pine, *Pinus contorta*  
 Noble fir, *Abies procera*  
 Sitka spruce, *Picea sitchensis*  
 Eastern larch, *Larix occidentalis*  
 White fir, *Abies coneolor*  
 White spruce, *Picea glauca*

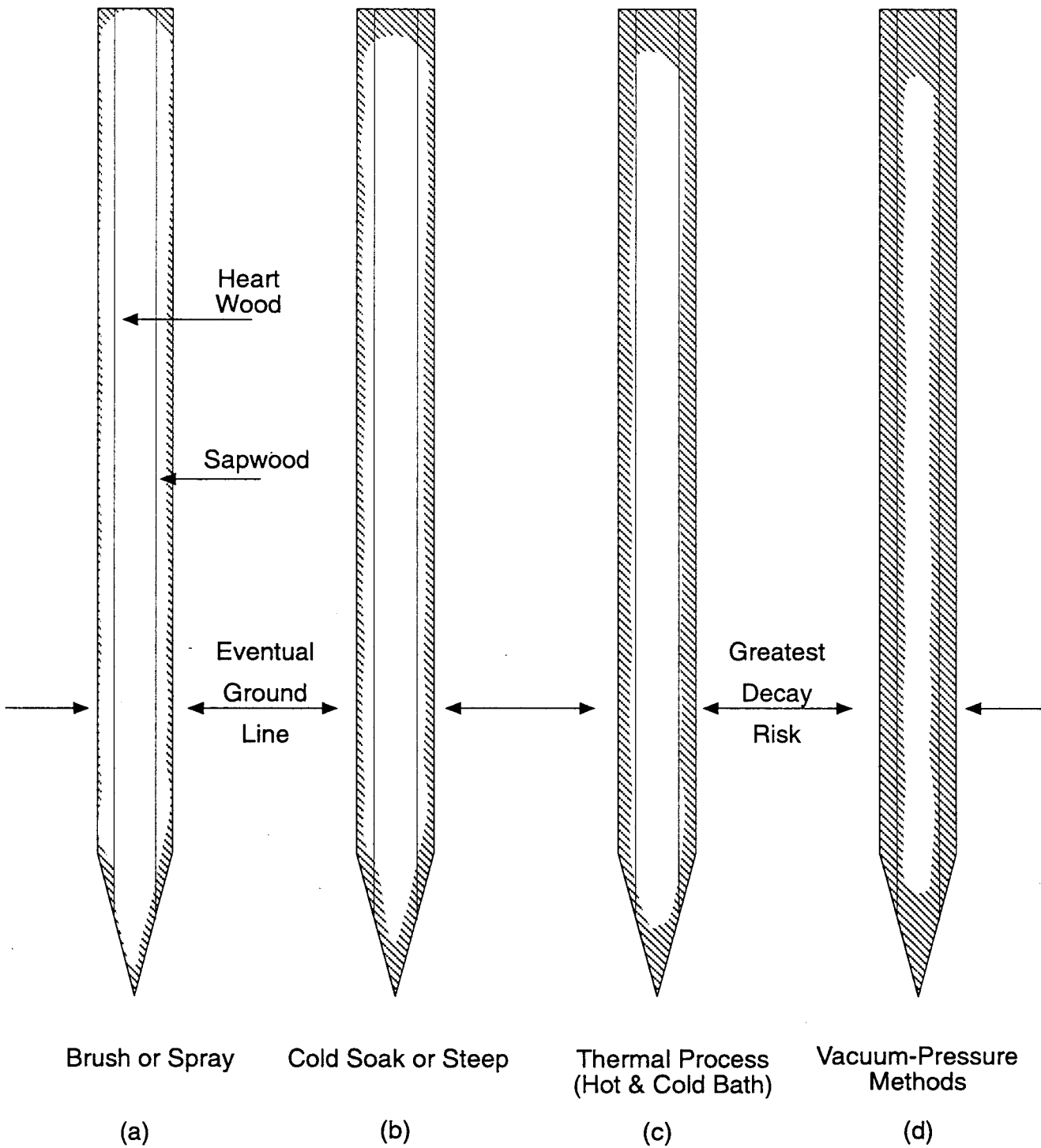
Hackberry, *Celtis occidentalis*  
 Rock elm, *Ulmus racemosa*  
 Sycamore, *Platanus occidentalis*

**Group 4. Heartwood Very Difficult to Penetrate**

Alpine fir, *Abies lasiocarpa*  
 Corkbark fir, *Abies lasiocarpa var. arizonica*  
 Douglas fir, (Intermountain type) *Pseudotsuga menziesii*  
 Northern white cedar, *Thuja occidentalis*  
 Tamarack, *Larix laricina*  
 Western red cedar, *Thuja plicata*

Beech (red heartwood), *Fagus amencana*  
 Black locust, *Robinia pseudoacacia*  
 Chestnut, *Castanea dentata*  
 Red gum, *Liquidambar styraciflua*  
 White oaks (except chestnut oak), *Quercus spp.*

Source: MacLean, J. D. 1935. *Manual on Preservative Treatment of Wood by Pressure.* USDA Misc. Publ. No. 224.



**Figure 5.2 a,b,c,d**  
**Effect of treatment on penetration**

Diagram of round pine fence posts, rip-sawn after treatment by four methods using the same preservative and showing the penetration pattern for each method.

Note that methods (a) and (b) leave untreated sapwood which could easily be exposed to decay through checks or splits that develop in the post as it dries out.



2. By holding the post below the surface of the preservative, a slight pressure is created which helps to force the preservative into the wood cells, thereby enhancing ordinary capillary action.

3. It is easier than having to rebrush or respray the post with more preservative at various intervals during the 24-hour treating period.

Unfortunately, although the penetration of preservative by soaking is better than by brushing, the ground-line area is still insufficiently-treated to provide long-term protection. Soaking was previously used commercially for treating fenceposts and rails, but pressure treatment has replaced it. Today, there are two principal uses for this treating method:

1. For exterior millwork such as window frame components. These parts get enough end-grain penetration to protect the very susceptible joints of the completed frame from decay in service.

2. For thin wood materials like trellis slats or lath panels for fencing. Modern pressure treatment, however, will give even better protection.

#### ***Thermal process or hot-and-cold bath***

When using the cold soaking or steeping method, a dry fence post was submerged for 24 hours in a tank of preservative at ambient (existing) temperature. With the thermal process or hot-and-cold bath, the same equipment is used, but the preservative is heated with the post in the tank (taking precautions against fire if it is oil-based). As the fencepost heats up, air in the wood expands and bubbles out, escaping through the preservative liquid into the atmosphere. The preservative is heated until no more air escapes from the post, and then the whole tank and submerged post is allowed to cool down. This process can also be completed in 24 hours. **Figure 5.2c**, page 47, shows the effect of this treatment on preservative penetration.

There are several ways to use the thermal process. It is not necessary to use just one tank in which to heat and cool the preservative for each batch of poles or posts treated. Two storage tanks and a separate treating tank can be used. One storage tank is insulated for the *hot preservative* and an uninsulated tank is used for the *cold solution*. Posts or other wood products are placed in the treating tank and soaked in the hot preservative solution for about 6 hours. Then the hot liquid is pumped back into the insulated tank and the cold preservative from the other storage tank is flooded around the wood products still in the treating tank. This system requires more equipment than cold soaking, but saves time and energy, lowers labor costs and provides better treatment.

The thermal process produces much better penetration than treating by the brushing, spraying or cold soaking methods. There are several reasons for this improvement. Much of the air in the cell cavities is forced to expand and escape from the outer post areas. When the preservative is allowed to cool, air remaining in the cells shrinks. So a partial vacuum is created in the cells and atmospheric pressure pushing on the treating liquid helps force more preservative into the post. For this reason, the thermal process might also be considered a non-equipment-induced vacuum-pressure method. Also by using heat, viscosity of the preservative solution (especially those thick with carriers) is reduced and it therefore penetrates the wood more readily. To enhance penetration, incising or puncturing the lower part of poles with slots or small holes is a necessary preparation required by AWPA standards for the thermal process.

The thermal process is used mainly for treating poles with creosote mixtures. The species preferred for this process are those which combine narrow sapwood bands with naturally durable heartwood. AWPA standards allow use of the thermal process for *full-length treatment* of western red cedar, Alaska yellow cedar and lodgepole pine poles and for *butt-only treatment* of western red, Alaska and



northern white cedar poles. In butt-only treatments, the poles stand with the butt ends immersed in the preservative to a depth one foot greater than the eventual ground line.

## Vacuum Pressure Methods

Conventional vacuum-pressure methods use *pumps* to create vacuum and pressure, thereby producing high pressure gradients and operator control over the process. By contrast the thermal process is limited to atmospheric pressure alone. However, by means of pumps, 10-12 atmospheres of pressure can easily and safely be produced. This is equivalent to about 140 to 175 pounds per square inch (psi) in a treating retort or cylinder. **Figure 5.2d**, page 47, indicates the penetration of preservative that might result from vacuum-pressure treatments. Although there are various vacuum-pressure methods available such as the Double Vacuum Process and the Mississippi State University Process, the principal methods used by the U.S. pressure-treating industry are:

- Full cell process (Bethell process)
- Empty cell processes (Lowry and Rueping)
- Modified full cell process

### Full cell process

This is the simplest and most common of the vacuum-pressure processes. It was developed by John Bethell in 1838. The full cell (or Bethell) process is used for most of the pressure treatments using chromated copper arsenate (CCA) and pentachlorophenol-based (PCP) preservatives, and a good proportion of the treatments with creosotes.

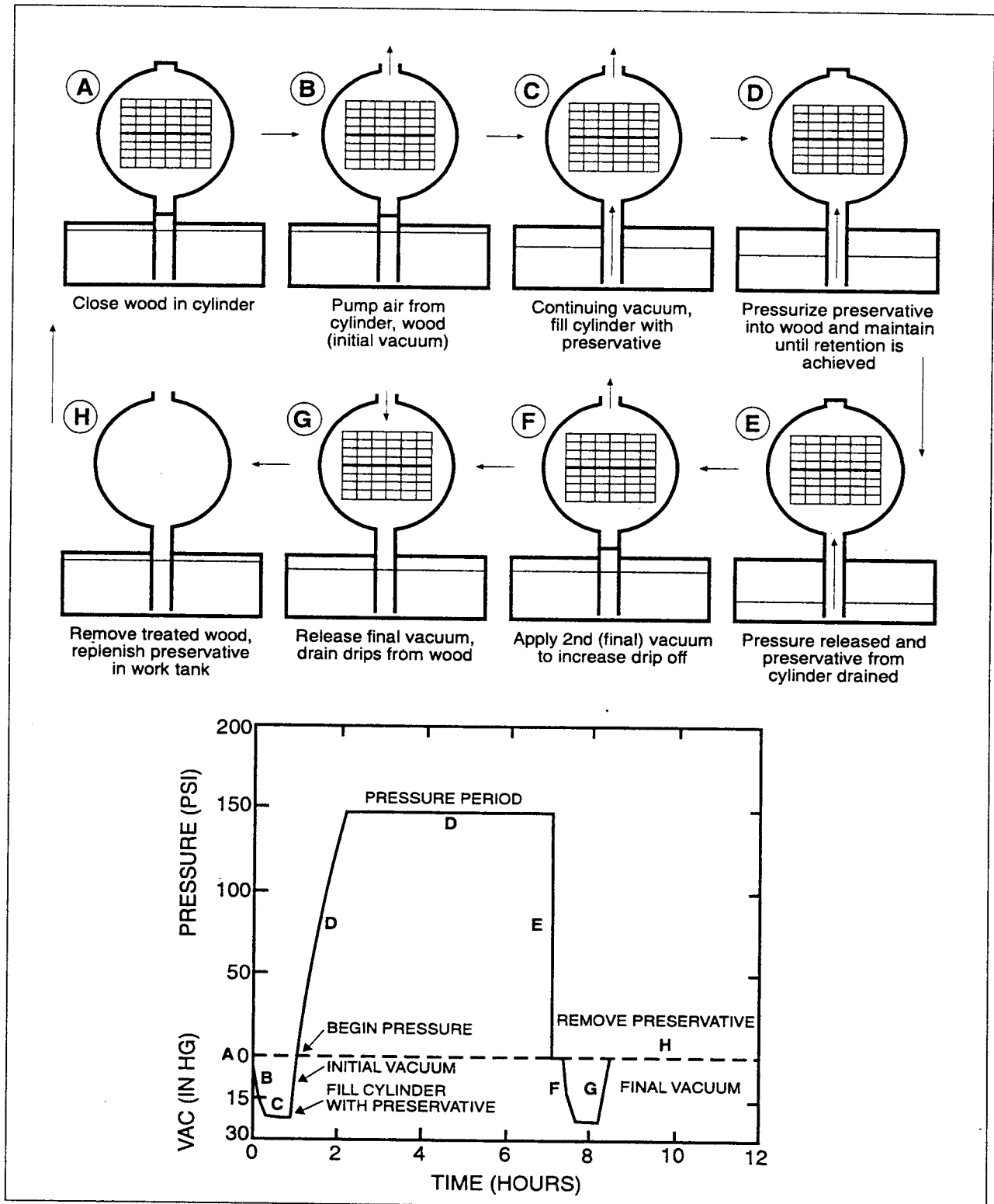
Features of the full cell process include:

- It gives the deepest possible penetration and the highest loadings (retentions) of preservative with easily-treated species. Virtually all of the air in the wood cells can be replaced with preservative. Sometimes this may produce a higher loading than necessary.

- The degree to which penetration and retention of preservative occurs depends on the permeability of the wood. For effective treatment, some species may need special preparation such as incising, steaming, or Boultonizing, which are described in a later section of this lesson.

No vacuum-pressure process is more effective than the full cell in maximizing the uptake or penetration of preservative. The sequence of procedures used in the full cell process is shown in **Figure 5.3**, page 50, and is summarized below:

- A. Enclose dried wood (timbers, lumber, poles, etc.) in a pressurable cylinder or retort.
- B. Use a vacuum pump to remove most of the air from the cylinder. Hold a partial vacuum to allow air to be removed from the wood cells.
- C. Without releasing the vacuum, allow the cylinder to fill with liquid preservative.
- D. Apply pressure to the preservative to force it into the wood cell spaces previously occupied by air, now occupied by a partial vacuum.
- E. When the desired and measured amount of liquid preservative has been absorbed, release the applied pressure and drain the cylinder (initial drain).
- F. Apply a "final" vacuum to expand the air remaining in the wood. This forces excess liquid to exude from the surfaces and run off.
- G. Release final vacuum. As the remaining air in the cells contracts, much of the surface wetness will be reabsorbed into the wood (this reduces dripping later).
- H. Remove the treated wood products from the cylinder.



**Figure 5.3**  
**Treating schedule for the full cell (Bethell) process**

*Adapted from Nicholas, Darrel D. 1973. Wood Deterioration and Its Prevention by Preservative Treatments. Vol. 2. Syracuse University Press, Syracuse, NY.*



### ***Empty cell processes*** ***(Lowry and Rueping)***

For some purposes, it is necessary to ensure deep penetration of preservative without leaving all the cells full of preservative. An example would be coal tar creosote treatment for an above-ground use, such as fence rails, which require a retention of 8 pounds per cubic foot (pcf) in accordance with AWWA Standard C2. A full cell process, giving full-depth penetration of sapwood, would likely produce a retention of 12 pcf (4 pounds more than required).

To ensure good depth of penetration, the *empty cell* process forces more creosote into wood than is needed, but then removes the excess to leave the average retention desired. Look at **Figures 5.4** and **5.5**, page 52, for the sequences followed during treatments with the Lowry and the Rueping empty cell processes. Both treating methods are similar to the full cell (Bethell) process except they omit the initial vacuum stage.

The *Lowry Process* is named for Cuthbert Lowry (1906, U.S.A.) In this process, after the wood has been closed in the cylinder, preservative is pumped in, and no air is allowed to escape. As the cylinder fills with liquid and pressure is applied, the air in the cylinder and in the wood cells is compressed into a smaller and smaller space. When the desired pressure is attained, air in the cells will occupy about one-tenth of the cell voids, and preservative can gradually fill up the other nine-tenths. The process then continues exactly as the full cell process, but the air compressed inside the wood expands when the pressure is released, thereby forcing some preservative out of the cells and eliminating overloading. The end result is that many cells are “lined” with preservative rather than “filled.” The final vacuum period can be used to extract more or less preservative as needed, so it acts as a retention control stage. The word “empty” in the term empty cell process is a poor description because cells are partly filled with preservative, in contrast with the word “full” which appropriately describes the full cell process.

The Lowry process is mainly used for treating wood with creosote, creosote/PCP mixtures and PCP preservatives.

The *Rueping process* is named for Max Rueping, (1902, Germany). This process is similar to the Lowry process. Here an air pressure higher than atmospheric is first applied to the closed cylinder and its charge of wood. The air pressure is generated by a compressor. A typical pressure used is four to five times atmospheric (about 60 psi). Treatment then continues as with the Lowry or full cell processes, but the amount of preservative removed (as the air compressed in the cells expands) is greater than in the Lowry process. This provides the necessary degree of penetration with even less final retention of preservative. The Rueping process also is mainly used with creosote, creosote/PCP mixtures and PCP preservatives. Other benefits of empty cell processes are:

- The final weight of treated wood is reduced compared to full cell treatment.
- A cost saving is realized from the use of less preservative chemical and carrier liquid.

### ***Modified full cell process***

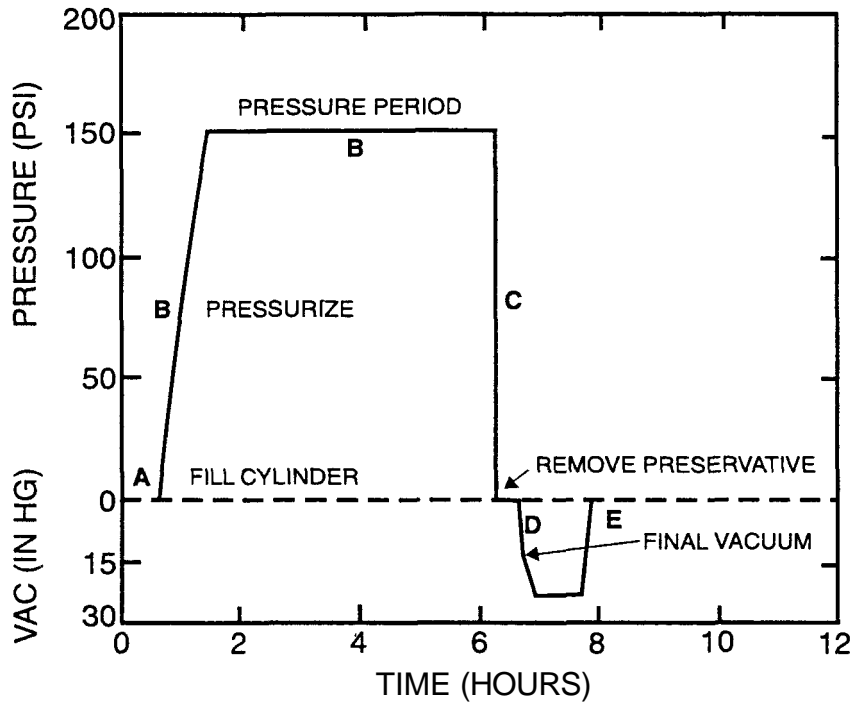
This process is an adaptation of the Bethell process for use with waterborne preservatives like CCA. It, too, achieves full sapwood penetration with a reduction in the weight of water left in the wood. This is important if the wood is to be shipped after treatment, without thorough air-drying or kiln-drying. The lower weight of the treated wood is reflected in lower shipping costs.

The modified full cell process calls for a lower degree or period of initial vacuum than the full cell. By leaving more air in the cells, a greater amount of absorbed preservative is rejected when the pressure period is over.

The concentration of CCA solutions can easily be changed, either by adding more CCA concentrate or more water. Usually higher concentrations of CCA are used with the modified full cell than with the full cell

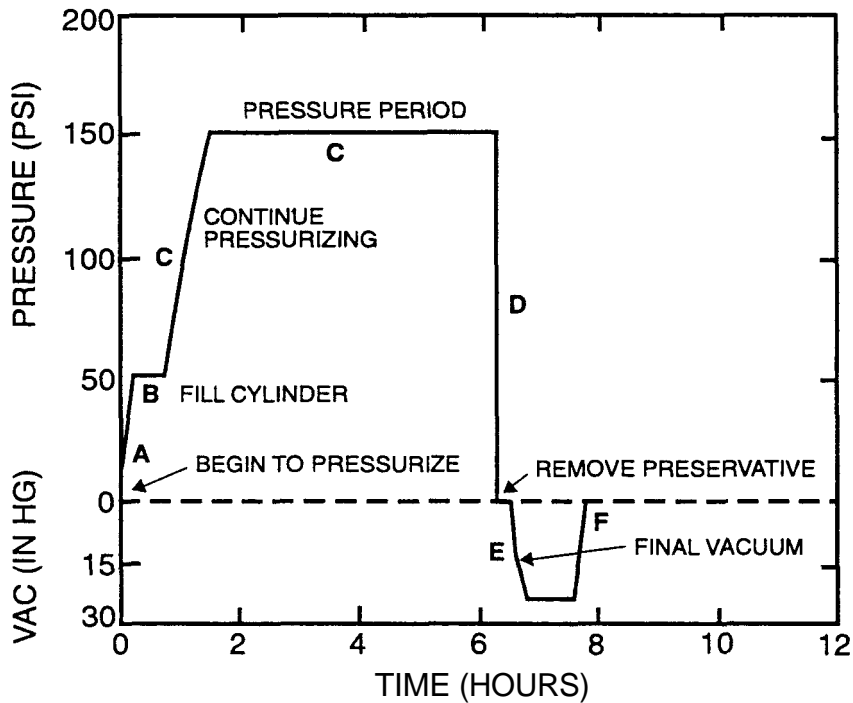


**Figure 5.4**  
Treating schedule of the Lowry (empty cell) process.



- Lowry (Empty Cell) Process**
- A** Fill cylinder with preservative at atmospheric pressure
  - B** Pressurize cylinder to maximum and maintain until retention is reached
  - C** Release pressure and withdraw preservative
  - D** Apply final vacuum
  - E** Release final vacuum

**Figure 5.5**  
Treating schedule of the Rueping (empty cell) process.



- Rueping (Empty Cell) Process**
- A** Partially pressurize cylinder
  - B** Fill cylinder with preservative
  - C** Continue pressurizing to maximum and hold until retention is reached
  - D** Release pressure and withdraw preservative
  - E** Apply final vacuum
  - F** Release final vacuum

Fig. 5.4 and 5.5 adapted from Nicholas, Darrel D. 1973. *Wood Deterioration and Its Prevention by Preservative Treatments*. Vol. 2. Syracuse University Press, Syracuse, NY.



process, and essentially the same weight of CCA chemical is left in the wood, but less water. A 20% reduction in overall weight of wood products treated in this way will give similar percentage savings in the cost of shipping undried products.

Technical Note: Before shipping, it is essential that treated wood has stopped dripping. A properly drained and covered drip-pad is used for this purpose. In the case of CCA preservatives, at least 24 hours should be allowed for chemical fixation to take place. Fixation time is appreciably longer in cold weather.

### Vacuum-Pressure Treating Plant Equipment

Equipment used to apply preservatives under pressure is not standard in design, but most systems are capable of wood treatment by the full cell, Lowry or modified full cell processes. The compressed air required for the Rueping process is not always available, but this process is not widely used.

The major item of a pressure-treating plant is the treating cylinder or retort, which can vary in size but is commonly 4 to 8 feet in diameter and 30 to 150 feet long. Auxiliary

equipment usually includes a boiler, dry kiln, pumps, tanks, gauges, thermometers, controllers and valves (see Figure 5.6).

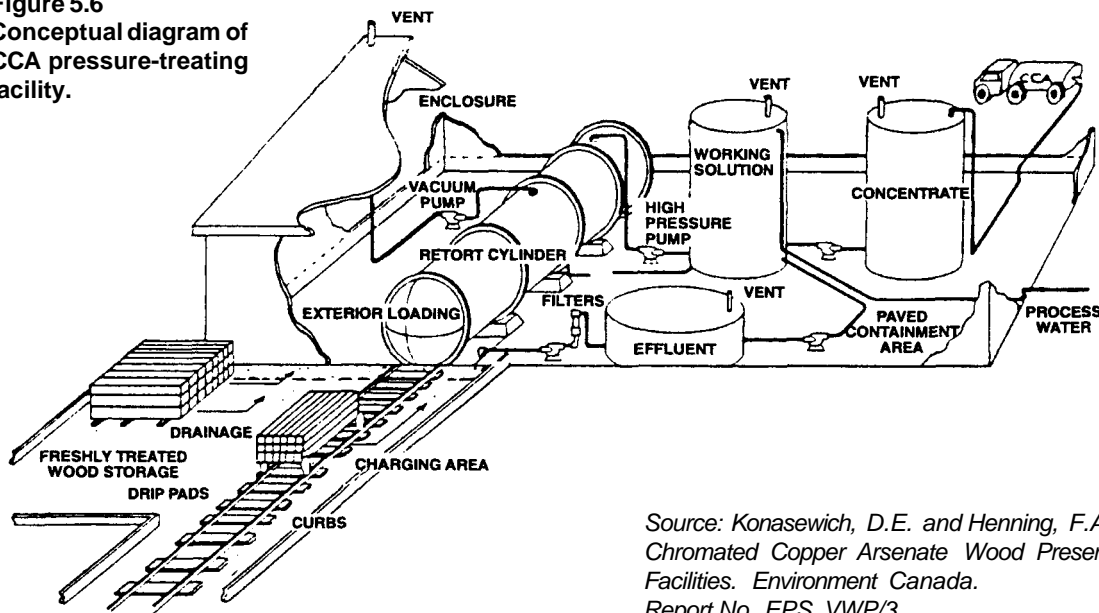
Specialized accessories such as incisors, steam generators, trams, hoists, lift trucks, debarkers, shavers, machinery for adzing and boring, condensers and water purification equipment are often needed. These are not usually directly connected with the pressure process, but rather with preparation of the wood items for treatment, or for pollution prevention.

### Preparation or Pretreatment of Wood for Vacuum-Pressure Application

Before wood cells can accept sufficient preservative liquid to satisfy preservation standards, the product to be treated must meet the following conditions:

1. There should be no bark or inner bark, paint, varnish or other impediments to surface penetration of preservative.
2. The wood product should be air-dried or kiln-dried to an average moisture content of 25% or less, unless pressure treatment is preceded by steam conditioning (drying green wood in the cylinder by steaming) or Boultonizing, described in the next section.

Figure 5.6  
Conceptual diagram of  
CCA pressure-treating  
facility.



Source: Konasewich, D.E. and Henning, F.A. 1988. Chromated Copper Arsenate Wood Preservation Facilities. Environment Canada. Report No. EPS .VWP/3.



3. Incising should be carried out whenever the treating standard calls for it. AWWPA standards require incising of many "difficult to treat" species to increase surface penetration and retentions (see the Standards for details).

### ***Boultonizing***

This conditioning or drying method is used with creosote preservative. It is an alternative to conventional wood seasoning, an essential step for good penetration. It is accomplished by enclosing green wood products (poles, crossties, timbers, etc.) in the treating cylinder and introducing creosote at 210° F to 220° F while applying a vacuum. Water, removed from the wood by evaporation, is then condensed in special equipment outside the cylinder. Since the boiling point of water (in the wood) is lower under a partial vacuum than at atmospheric pressure, drying can occur rapidly at temperatures below 212° F (depending on the proportion of sapwood to heartwood). Although Boultonizing does not thoroughly dry wood, it improves the ability of many wood species to accept preservative by the conventional full cell process which follows Boultonizing. (See AWWPA standards for commodities and species allowed for Boultonizing .

### ***Steaming***

In this preconditioning process, green or partially seasoned wood items are first subjected to pressurized steam at about 240° F for a limited time. The AWWPA standards define the species, temperature and time allowed. Over-steaming reduces the strength of wood, often seriously, but a controlled steaming process, like Boultonizing, can reduce the moisture content of green wood products to a condition acceptable for treatment. Steaming is not used as extensively as it once was, and is mostly practiced today with west coast softwood species.

### ***Incising***

This is a process of mechanically puncturing the outer surfaces of wood products, usually poles, crossties, timbers and sometimes lumber. Slots or holes of a controlled depth and spacing are made. This improves the uptake of preservative in "difficult-to-treat" species, and helps provide a treated zone around the outside of the wood item. AWWPA standards specify which species and commodities should be incised (Table 6.2, page 62).

## **Units of Measure Used in Wood Preservation**

### ***Units of vacuum***

The science of physics defines a total vacuum as a condition in which there is an absence of matter, such as in a container. In pressure terms, a total vacuum has zero pressure, that is, there are no gas molecules to create a pressure on the container. The only easy way that vacuum can be measured is by comparison with a higher pressure, usually atmospheric pressure (explained below). The units used to express vacuum are *inches of mercury* or *in. Hg* (Hg is the chemical symbol for mercury). Mercury is used because it is a very dense liquid. If the bottom end of a glass tube is inserted into a container of mercury and a vacuum is created at its upper end, mercury will tend to move up the tube. The height of the column of mercury in the tube, above the level of mercury in the container, can be measured with a rule.

When no vacuum is applied, the mercury is the same level both inside and outside of the tube. A reading of 0" Hg tells us there is zero or no vacuum. As the vacuum is increased, mercury rises inch by inch inside the tube (1" Hg, 2" Hg, 3" Hg, and so on). The maximum possible vacuum (no molecules of gas) would give a reading of 30" Hg, if the air outside was average barometric pressure found at sea level.

Note: A typical initial vacuum level for the full cell process is 22" to 28" Hg.



In practice, the gauges used with treating equipment have rotating needles or moving recorder pens. Although they are not mercury-filled, the gauges are calibrated against a mercury column.

### ***Units of pressure***

Although there is no real reason why pressure could not be measured with mercury, as for a vacuum, it is normal to express pressure as the force, in pounds, exerted by a gas or liquid on one square inch of surface; that is pounds per square inch or psi. The air around us is at a positive pressure. Compared to a total vacuum, atmospheric pressure at sea level averages about 15 psi. Pressure gauges normally read zero if there is no pressure above atmospheric pressure. This is referred to as a gauge pressure of zero (actually it is an atmospheric pressure of 15 psi). The gauge pressure used when treating wood is normally 150-200 psi.

### ***Units of liquid volume***

Preservative volumes are measured in U.S. gallons.

### ***Units of wood volume***

In the treating process actual cubic feet of wood material is the correct unit of volume to use for the treatment charge. This is the volume obtained for each individual item by measuring its actual dimensions (whether lumber, poles, timbers or plywood), then calculating the volume in cubic feet of each item and adding them all together. This explanation must be emphasized because the nominal dimensions used in the lumber trade are seldom the actual dimensions of the lumber. For example, if you calculate the volume of a 10 foot 2x4 and assume it is 2"x4"x10" you would get 0.555 cu. ft.

$$\frac{2''}{12''} \times \frac{4''}{12''} \times \frac{10'}{1} = \frac{80}{144} = 0.555 \text{ cu.ft.}$$

This calculation is correct for a piece of lumber with actual 2"x4"x10' dimensions. However, 0.555 cu. ft. is incorrect for determining the volume of a treatment charge because 2x4 lumber, when dressed or planed, actually measures only 1-1/2" x 3-1/2" in cross-section. The stated lengths of lumber, however, are actual lengths. So the correct volume of a 10 foot 2x4 to be used for determining treating charge volume is 0.365 cubic feet:

$$\frac{1.5''}{12} \times \frac{3.5''}{12} \times 10' \text{ (Convert all dimensions to feet):}$$

$$= \frac{5.25}{144} \times 10' = 0.365 \text{ cu. ft.}$$

The error obtained in calculating the volume of this one piece of lumber was 52% too high and could have seriously affected the amount of preservative required for the charge.

$$\frac{0.555 - 0.365}{0.365} = \frac{0.190}{0.365} = 52\%$$

### ***Units of retention***

Retention is always expressed in pounds of preservative chemical per cubic foot of actual charge volume (lb/cu. ft. or pcf). With creosote, which is both the preservative and the carrier liquid, the total weight of creosote in the wood is used in computing the pcf retention. Not all of the wood in a charge will accept the same amount of preservative, therefore several pieces should be tested to ascertain average retention. Most other preservatives, particularly PCP, ACA and CCA, are carried into the wood in a petroleum solvent or water. The weight of the carrier for these preservatives is relatively unimportant in deciding the retention of the preservative. What matters is the weight of active chemical per cubic foot of wood.

Retention of pentachlorophenol is expressed as lb. PCP/cu. ft. or pcf PCP.

Retention of chromated copper arsenate preservatives is expressed as lb. CCA/cu. ft. or pcf CCA. All CCA preservatives are



considered to be 100% oxide materials, that is, the water carrier is ignored and the preservative is considered to conform with the formula required for CCA types A, B or C (given in Lesson 3).

### *Units of shipping volume for wood items*

Lumber is conventionally sold by the board foot; poles by length and diameter at the butt, at the tip or six feet from the butt; plywood and other panel materials by the square foot and thickness.

The prefix M usually means one thousand, and BF or b.f. refers to board feet. Therefore:

1 MBF = one thousand board feet

1 MMBF = one million board feet

Board feet is the common unit of measure for marketing both untreated and treated lumber, but in the wood-treating process itself the b.f. unit is not used.

### Units of penetration

Penetration is measured in inches or in percentage of total sapwood penetrated. To see the extent of preservative penetration, increment borings are taken out of sample pieces of treated wood. Depth of creosote penetration is usually easy to see because of its color. With PCP and CCA, spray-on chemicals that enhance detection of the preservative color are available. Penetration and retention of preservative is usually more effective in roundwood products than in squared stock because of their higher proportion of sapwood. The AWPA standard for each commodity and species details the penetration demanded of a given preservative.

## Self-Testing Questions - Lesson 5

(Some questions may have more than one answer)

**1. When a preservative penetrates a softwood, which cells carry it in a longitudinal direction?**

- (a) Fibers
- (b) Fiber tracheids
- (c) Ray tracheids
- (d) Vessel segments

**2. Which hardwood cells are largely incapable of conducting liquids?**

- (a) Fibers
- (b) Fiber tracheids
- (c) Ray tracheids
- (d) Vessel segments

**3. Which cells are mainly responsible for the strength of hardwoods?**

- (a) Fibers
- (b) Fiber tracheids
- (c) Ray tracheids
- (d) Vessel segments

**4. Which surfaces or faces of both softwoods and hardwoods do not absorb much preservative?**

- (a) Transverse
- (b) Tangential/Longitudinal
- (c) Radial/Longitudinal

**5. Which of these factors encourages the absorption of preservative into wood cells?**

- (a) Air in the cells
- (b) Capillary action
- (c) Unpitted cell walls

**6. Which of these species do AWPA standards allow to be treated by the thermal process?**

- (a) Western hemlock
- (b) Western red cedar
- (c) Western white pine
- (d) Alaska yellow cedar

**7. In the full cell process, which stage follows the pressure period?**

- (a) Initial drain
- (b) Final vacuum
- (c) Initial vacuum
- (d) Fill

**8. Which treating method uses an initial air pressure of about 60 psi as part of its sequence?**

- (a) Bethell
- (b) Lowry
- (c) Rueping
- (d) Full cell

**9. Which preparatory treatment for green wood uses an applied vacuum?**

- (a) Boultonizing
- (b) Incising
- (c) Presteamming
- (d) Kiln-drying

**10. The pressure of the atmosphere at sea level (known as 1 atmosphere) is equal to about 15 psi. About how many atmospheres of pressure are used in a treating plant run at 165 psi gauge pressure?**

- (a) 5 atmospheres
- (b) 7 atmospheres
- (c) 9 atmospheres
- (d) 11 atmospheres

**NOTE:** Answers are given at the end of the program.





---

# Lesson 6:

## Treating Regulations, Standards and Quality Control

### Introduction

In the U.S., various codes and standards are used by consumers of treated wood products that specify where, when and how treated wood should be used.

Lesson 6 discusses these codes and standards and describes how the treating industry maintains high quality standards through self-inspection practices and routine sampling by quality control agencies.

### Groups Influence Use of Treated Wood

Various agencies prescribe where, and under what conditions, treated wood will be used. Primary among these groups are: government agencies, utility and railroad industries and architects and builders.

#### *Government agencies*

Many federal, state, county and city government agencies in the U.S. specify treated wood for a variety of uses such as military installations, building and bridge construction, docks, piles, poles and posts. The federal government also issues standards and specifications for preservatives and treatments.

#### *Utility and railroad industries*

Large numbers of treated poles are used by electric and telephone companies. Water and gas utilities also specify large volumes of treated wood. The railroads buy many treated crossties annually.

#### *Architects and builders*

Building codes specify treated wood in various situations, particularly for in-ground and ground-line uses. For technical reasons, architects or builders often extend their pre-

scription and use of treated lumber to include siding, decking, lattice, other exterior products, and sometimes interior applications.

#### *Farmers*

Most farmers are familiar with the benefits of wood preservation, so they specify and use treated wood for fencing, gates, pole barns and other farm construction projects.

#### *Homeowners*

Do-it-yourself projects consume a large proportion of treated wood products. The main uses for this group are outdoor construction such as decking, landscaping and fencing. The appeal of treated wood is strong when its use is guaranteed against decay and termite attack for 30 years or more.

### Codes and Standards

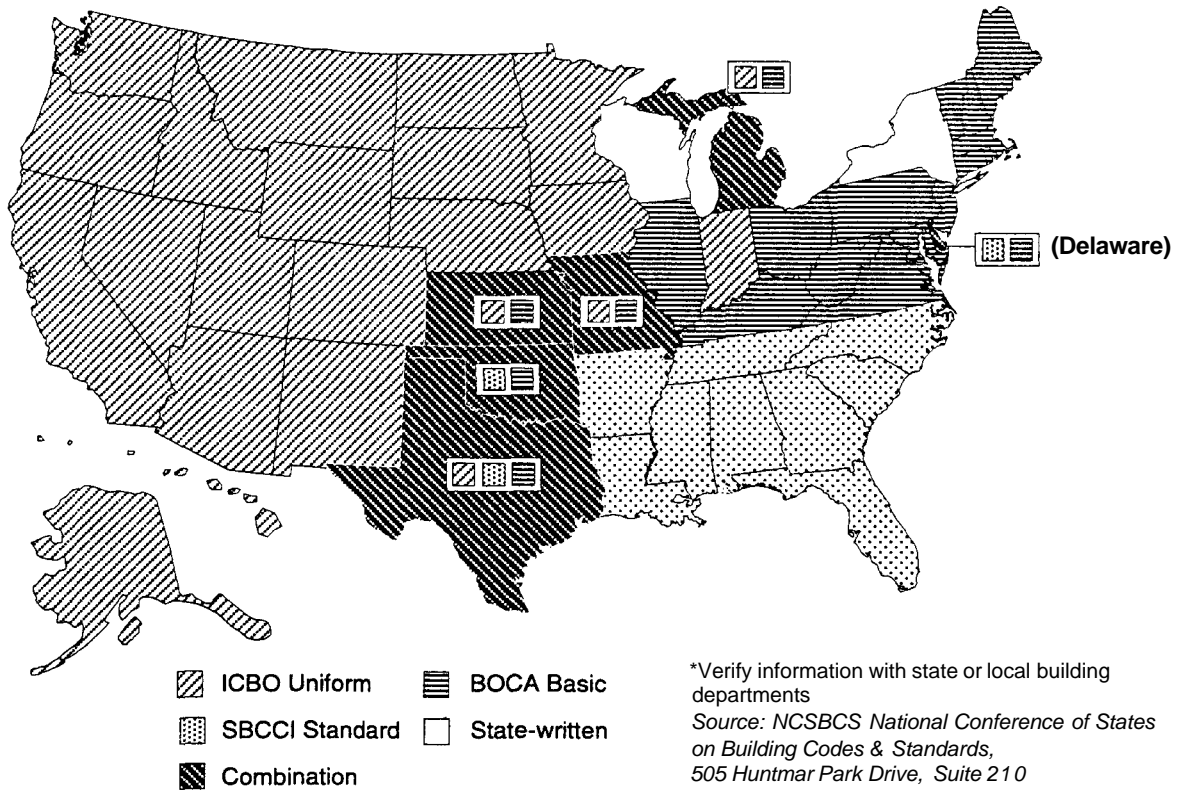
There are many regulations and various agencies that govern the preservative treatment of wood and influence where, when and how it can be used in construction. These regulations, for the most part, are incorporated in building codes and standards. It is important to distinguish clearly between codes and standards with regard to preservative treated wood. Building codes, in addition to other construction regulations, dictate the conditions under which treated wood must be used. Standards detail how wood should be treated with preservatives.

#### *Building codes*

Building codes are ordinances written to protect the life and safety of a building's occupants and the public. They govern the materials and building practices to be used in residential, commercial and industrial con-



**Figure 6.1**  
**General areas of building code influence\***



\*Verify information with state or local building departments

Source: NCSBCS National Conference of States on Building Codes & Standards, 505 Huntmar Park Drive, Suite 210 Herndon, Virginia 22070 (703) 437-0100 (1/92)

struction throughout the country. All U.S. cities, counties and states have legally adopted construction regulations from one of the three model building codes. These codes are sometimes modified for local use, especially in small communities and by large metropolitan areas.

The principal geographical areas of building code influence are illustrated in **Figure 6.1**. The model building codes used in the United States are:

- *The Basic Building Code (BOCA)*, written by the Building Officials and Code Administrators International, Inc., used in the Northeast and Great Lakes states, Oklahoma, Missouri, Kentucky and Virginia.
- *The Standard Building Code (SBCCI)*, written by the Southern Building Code Congress International, Inc., used in the Southeast states and part of Texas.

- *The Uniform Building Code (ICBO)*, written by the International Conference of Building Officials, used in the Midwest and Southwest, Alaska and Hawaii.

#### **AWPA standards**

The United States is fortunate in having the Standards issued by the *American Wood Preservers Association (AWPA)*. Wood commodities covered in the 1992 AWPA standards are listed in Table 6.1. These are the most comprehensive and detailed wood preserving standards available anywhere in the world. They specify the factors relating to pressure treatment for nearly all uses of treated wood. The standards also list the wood species and preservative retentions recommended. Every student of this program is strongly advised to obtain a copy of the current AWPA standards, available for a small



**Table 6.1**  
**Wood commodities covered in the American Wood Preservers Association standards for 1992**

Standard	Wood Commodities
C1*	All timber products, pressure treatment
C2*	Lumber, timbers, bridge ties and mine ties, pressure treatment
C3*	Piles, pressure treatment
C4*	Poles, pressure treatment
C5*	Posts, pressure treatment
C6*	Crossties and switch ties, pressure treatment
C7	Incised (red, white and yellow cedar) pole butts, thermal treatment
C8	Poles (western red and Alaska yellow cedar), full-length thermal treatment
C9*	Plywood, pressure treatment
C10	Poles (lodgepole pine), full-length thermal treatment
C11	Wood blocks for floors and platforms, pressure treatment
C12	Poles (western larch), full-length thermal treatment
C14	Wood for highway construction, pressure treatment
C15*	Wood for commercial-residential construction, pressure treatment
C16	Wood used on farms, pressure treatment
C17*	Playground equipment treated with inorganic preservatives, pressure processes
C18*	Material in marine construction, pressure treatment
C20	Structural lumber, fire-retardant pressure treatment
C22*	Lumber and plywood for permanent wood foundations, pressure processes
C23*	Pole building construction, pressure treatment
C24*	Sawn timber piles used for residential and commercial building, pressure processes
C25*	Crossarms, pressure treatment
C27	Plywood, fire-retardant pressure treatment
C28*	Structural glued laminated members and laminations before gluing, pressure treatment
C29	Lumber to be used for the harvesting, storage and transportation of food stuffs
C30	Lumber, timbers and plywood for cooling towers, pressure processes
C31*	Lumber used out of contact with the ground and continuously protected from liquid water
C32	Glue laminated poles of southern yellow pine or coastal Douglas fir

\* Some or all of the AWWPA commodity standards marked with an asterisk\* are used by American Lumber Standard Committee accredited agencies, which supervise facilities that pressure-treat wood products. (Also see Figure 6.2.)



charge from AWPAs. (See the List of References for the address).

The standards are reviewed each year by members of the AWPAs technical committees, and are updated regularly. Treatment information discussed in this program comes from the 1992 edition. (Always refer to the current

year's AWPAs standards for up-to-date details.)

**Table 6.2** lists wood species permitted for different end uses. Over the years, AWPAs committees have considered each available species in terms of the permeability of both its sapwood and the heartwood, the natural

**Table 6.2 Species permitted for various treated wood products<sup>1</sup>**

AWPA Standard	Lumber, Timbers & Ties	Piles		Poles	Fence Posts (quartered or fully round)	Cross-ties	Lumber & Plywood for Permanent Wood Foundations
	Above Ground, Soil Contact & Fresh Water Applications	Soil Contact & Fresh Water Applications	Foundations				
	C2	C3	C3	C4	C5	C6	C22
S. Y. pine	P	P	P	P	P	IO,xa	P
Ponderosa pine	P	P	P	P	P	IO,xa	P
Red pine	P	P	P	P	P	IR,xa	P
Coastal Dgls. fir	IR	P	P	P	RP	IR,xa	P
W. hemlock	IR	NR	NR	NR	RP	IR,xa	P
Hem-fir	IR	NR	NR	NR	NR	NR	P
E. white pine	IR	NR	NR	NR	NR	NR	NR
Redwood	IR	NR	NR	NR	NR	NR	NR
Jack pine	IR	P	P	P	P	IR,xa	NR
Lodgepole pine	IR	P	P	P	P	IR,xa	NR
(Idaho) white pine	IR	NR	NR	NR	NR	NR	NR
Radiata pine	P	NR	NR	NR	NR	NR	NR
Caribbean pine	P	NR	NR	NR	NR	NR	NR
Alpine fir	IR	NR	NR	NR	NR	NR	NR
W. white spruce	IR	NR	NR	NR	NR	NR	P
Englemann spruce	IR	NR	NR	NR	NR	NR	NR
Oaks, red & white	P	P,xa	P,xa	NR	NR	IO,xa	NR
Maple	P	NR	NR	NR	NR	NR	NR
Black/red gum	P	NR	NR	NR	NR	NR	NR
Western larch	NR	P	P	P	RP	IR,xa	NR
Int. Douglas fir	NR	P	P	NR	RP	NR	NR
W. red cedar	NR	NR	NR	P	NR	NR	NR
Hickory	NR	NR	NR	NR	NR	IO,xa	NR
Mixed hardwoods	NR	NR	NR	NR	NR	IO,xa	NR
Cypress	NR	NR	NR	NR	NR	IR,xa	NR
Inter-Mtn. Dgls fir	NR	NR	NR	NR	NR	IR,xa	NR

**KEY:**

- P = Species permitted for each use (but not necessarily with all preservatives)
- RP = Species permitted, but round posts only
- IR = Species permitted, but incising required before treatment
- IO = Species permitted, incising optional
- NR = Not recommended
- xa = Species permitted, except with inorganic arsenical preservatives

Notes to Table 6.2: 1. This table cannot record every circumstance covered in the AWPAs Standards. The Standards should always be referred to before specifying a treated commodity for the first time.  
 2. The Standards specify minimum depths of penetration, retentions and other requirements.

<sup>1</sup>Based on AWPAs Standards, 1992



durability of its heartwood, the size and shape of the commodity and its permissible uses. Where experience or field trials have shown a service life of at least 30 to 40 years, the wood species was named in the standard. Excluded are those species which do not promise good performance or which are not normally used for specific applications and circumstances. Aspen, for example, is not listed in the AWPB standards since experience has proven it “treats” very poorly and its performance is very inconsistent.

### ***Other standards and specifications***

For most purposes, reference to an individual AWPB standard should be sufficient to ensure well-treated products. Treated wood, however, is sometimes specified without direct reference to the AWPB standards. This may occur where special requirements or adaptations have been prescribed by large wood-using authorities (for example government agencies, railroads and utility companies) or where no AWPB standard exists for a particular product or use.

One example is U.S. Federal Specification TT-W-571, which lists the treating requirements used by most federal government departments when specifying treated wood. Preservatives used on federal projects are defined in Federal Specification:

- **TT-C-645** for coal tar creosote;
- **TT-W-550** for chromated copper arsenate (CCA); and
- TT-W-570 for pentachlorophenol (PCP).

### **Quality Control of Treated Wood by Agencies**

Prior to January 1993, the *American Wood Preservers Bureau (AWPB)* administered a quality control program available to the U.S. wood-preserving industry. The AWPB in the past had its own set of standards (which basically referenced the AWPB standards). It certified certain inspection and testing agencies, and it permitted the use of an AWPB

grade stamp to wood treaters and inspection agencies that met its quality control criteria.

Beginning January 1, 1993, however, a new quality control program administered by the *American Lumber Standards Committee (ALSC)* and endorsed by the wood-treating industry became effective. Under the new program, only AWPB standards are used—AWPB standards are phased out. In addition, the ALSC has been authorized to provide inspection and accreditation of those inspection agencies, that adhere to AWPB standards. It should be noted that not all of the AWPB commodity standards are used by the ALSC and its accredited agencies—only those standards dealing with pressure-treated wood products, (see **Table 6.1**, page 61). Nine agencies as of March 1994 are accredited by the ALSC and are listed in **Figure 6.2**, page 64.

Conformance with AWPB standards and inspection by an ALSC-accredited agency permits wood treaters to use the approved quality marks of the supervising agency on their treated products. Although some firms “self-audit” themselves and may have their own trademarks, it is estimated that 80 to 90 percent of the treated wood in the U.S. is inspected under the supervision of ALSC-accredited agencies.

Most wood-using consumers and building code inspectors have a keen awareness of what constitutes a quality product and they look for that assurance of quality in the form of a certified quality mark. Wood treaters who follow AWPB standards and subscribe to the inspection services of an ALSC-accredited agency will certainly have a marketing advantage over those treaters who don't.

Although most treated wood products used for construction are subject to building codes, AWPB standards and a quality assurance program, not all treated products are regulated in that manner. The utility industries, for example, buy large quantities of treated wood products, and they have developed detailed standards covering such factors as size, shape, moisture content, allowable defects, preserva-



**Figure 6.2**  
**Agencies accredited by the Board of Review of the American Lumber Standard Committee\* and their typical quality marks for supervisory and lot inspection of pressure-treated wood products. March 1994**



**Bode Inspection, Inc.**  
 P.O. Box 591  
 Lake Oswego, OR 97034  
 (503) 636-2181



**California Lumber Inspection Services**  
 P.O. Box 6989  
 San Jose, CA 95150  
 (408) 241-2960



**Florida Lumber Inspection Service**  
 P.O. Box 1363  
 Perry, FL 32347  
 (904) 584-5221



**McCutchan Inspections, Inc.**  
 8525 N. Lombard Street  
 Portland, OR 97203  
 (503) 286-0977



**PFS Corporation**  
 2402 Daniels Street  
 Madison, WI 53704  
 (608) 221-3361



**Southern Pine Inspection Bureau**  
 4555 Old Spanish Trail Road  
 Pensacola, FL 32504  
 (904) 434-5011



**Timber Products Inspection**  
 P.O. Box 919  
 Conyers, GA 30207  
 (404) 922-8000



**West Coast Lumber Inspection Bureau**  
 P.O. Box 23145  
 Portland, OR 97223  
 (503) 639-0651



**Warnock-Hersey**  
 211 Schoolhouse St.  
 Coquitlam, BC V3K 4x9  
 (604) 520-3321

**Interpreting a Quality Mark**

1. The identifying symbol, logo or name of the accredited agency.
2. The applicable American Wood Preservers Association (AWPA) commodity standard.
3. The year of treatment if required by AWPA standard
4. The preservative used, which may be abbreviated.
5. The preservative retention.
6. The exposure category (for example, above ground, ground contact, etc.)
7. The plant name and location; or plant name and number; or plant number.
8. If applicable, moisture content after treatment.
9. If applicable, length and/or class.

\* American Lumber Standard Committee  
 P.O. Box 210  
 Germantown MD 20874-0210  
 (301) 972-1700



tive retention and penetration. Treaters must submit full test data with each pole and batch of crossarms supplied. In addition, utility companies conduct their own spotchecks to verify delivered quality of treated products purchased. In a similar way, the railroad industry oversees stringent quality control procedures for the treated crossties, timbers and pilings purchased.

### **Quality Control by the treater**

Treaters are well-advised not to rely entirely on the inspection services of an outside agency. Quality control is the daily responsibility of each treating company, and careful records and tests should be made and kept on each charge treated. The operator or treater must know (rather than “assume,” “guess” or “hope”) about the following facts for each charge.

#### ***Moisture content***

In vacuum pressure treatment, without presteaming or Boultonizing, wood will not treat properly if the cell cavities are partly full of water, so wood must be dried before treatment. Some specifications state a maximum moisture content for the wood; in the absence of this, a good general rule is that no item in the charge should have a moisture content above 25 percent. Moisture content for preservative treating purposes is usually measured with an electrical moisture meter. Its needles or probes are inserted into the wood to the correct depth required for preservative penetration (the assay zone). An average MC of 25 percent may not be low enough (the wood may not be dry enough) for some treatments, species and end uses. Experience may dictate that a lower MC is required. Sufficient readings from different parts of the charge to be treated should be made to give reasonable confidence that all pieces are dry enough to be treated properly. How to use electrical moisture meters:

- Take care of the meter and probes to prevent damage. Check batteries daily.
- Calibrate the meter carefully as directed.
- Most meters cannot provide accurate MC data above 28 percent, but they do provide reliable MC readings below 28 percent. A moisture meter reading of over 28 percent MC merely tells us that the wood is too wet to treat, and must be dried further.
- The MC reading you get when using uninsulated probes is an average across the depth of wood penetrated by the probes. Some meters have probes that are insulated so that the readings they produce are for the layer of wood to which the probes penetrate.
- Always probe sufficiently deep in the wood so that you test the full area or zone to be treated.
- When moisture meters are used after a charge of wood has been treated, the readings may have to be corrected as some preservative chemicals affect the electrical conductivity of the wood. The preservative supplier will advise as to the correction required.

#### ***Charge volume***

The example of cubic foot volume given in Lesson 5 shows the need to be careful in making treating-charge volume calculations. Always use actual dimensions obtained by measuring samples of each wood product in the charge with a tape or rule. (Do not accept anyone else’s word on sizes). Actual cubic foot volumes of rectangular items such as lumber and timbers are easily calculated from actual dimensions of width, thickness and length (each converted to feet or fractions of feet). Then total charge volume is obtained by adding up the volumes of all the component items.



Volume of round, halfround and other odd-shaped wood products are more difficult to calculate, but formulas are available for making these conversions. AWWA Standard F3 contains tables for converting the length and diameter of round items (poles, piles, posts) to actual cubic foot volumes.

### ***Heartwood content***

Several species including redwood, Douglas fir and the cedars have reasonably durable heartwood. For those species the treating standards assume that, if the sapwood is well-treated and only a shallow penetration is achieved in the heartwood, life-expectancy of the item is good. In order to get a specified retention of preservative in the sapwood, the volume of any heartwood present can virtually be ignored. The plant operator or treater should estimate the percentage of heartwood volume in each charge and discount that number of cubic feet from the actual total charge volume before calculating how many gallons of preservative have to be retained by the charge.

### ***Specified requirements***

Plant operators must know the retention and depth of penetration specified before they can determine and set the treating solution concentration and the vacuum and pressure periods. Plant operation is half art, half science. Good operators know the above details for every charge. They should learn well and then use their experience to produce treated products which will satisfy any inspector. *The plant operator is the most valuable person in a treatment operation.*

### ***Considerations after treating***

The treating tank gauges show the volume of preservative absorbed or retained in each treated charge which is called *retention by gauge or weight*. This can be converted to a weight of preservative chemical (creosote, PCP, CCA, etc.). This data and all other pertinent details of each treatment should be noted on a charge sheet for immediate confirmation of treatment, and for later reference when needed. The operator will therefore know the *average* retention of preservative chemical per cubic foot of treated wood products.

How does one check quality of treatment and determine that individual pieces in the charge are properly treated? Using an *increment borer*, cores are taken from at least 20 different pieces of treated material to fairly represent the dimensions, shapes and positions of pieces in the charge. Each core must contain sapwood at least 0.6" thick (this is the "retention zone" of most AWWA standards). The operator then checks to see that the preservative penetrates the sapwood to the depth specified in the standard. The operator may use a *chemical reagent* to enhance the preservative color and show its presence clearly. Assuming each of the 20 sapwood cores is properly penetrated with preservative and the charge sheet shows enough average preservative retention, the operator can be reasonably sure that the wood is well-treated. For confirmation, the 20 cores can be sent away to an ALSC-certified lab for chemical analysis, called assay or *retention by assay*, to confirm the chemical loading. The AWWA standards give full instructions for sampling, penetration tests and analysis methods.

## Self-Testing Questions - Lesson 6

*(Some questions may have more than one answer)*

**1. Which building code is applicable in:**

	Minnesota	Georgia	Wisconsin	Illinois
Basic (BOCA)	(a)	(e)	(i)	(m)
Standard (SBCCI)	(b)	(f)	(j)	(n)
Uniform (ICBO)	(c)	(g)	(k)	(o)
State-written	(d)	(h)	(l)	(p)

**2. Are the following statements true or false?**

- |  |     |     |
|--|-----|-----|
| (i) Jack pine is suitable for lumber and timbers without incising.   | (T) | (F) |
| (ii) Treated aspen is suitable for lumber.   | (T) | (F) |
| (iii) Eastern white pine must be incised if used for lumber.   | (T) | (F) |
| (iv) Red pine treated with CCA is suitable for crossties.  | (T) | (F) |
| (v) Southern yellow pine, Ponderosa pine and red pine are suitable for lumber, piles, poles, posts, crossties and plywood. | (T) | (F) |

**3. Which of these species, if treated, is recommended for freshwater piling?**

- (a) Western larch
- (b) White-oak
- (c) Hemlock-fir
- (d) Western red cedar

**4. Which wood species is recommended for railroad crossties if treated with CCA or ACA?**

- (a) Hickory
- (b) Coastal Douglas fir
- (c) Jack pine
- (d) Red oak
- (e) None of the above

**5. Treating standards dictate the conditions under which treated wood must be used.**

- (a) True                      (b) False

**6. An average moisture content of 25 percent is low enough to treat all wood products.**

- (a) True                      (b) False

**7. Functions of the AWPB are now carried out by the ALSC.**

- (a) True                      (b) False

**8. Retention by assay is more accurate than retention by gauge.**

- (a) True                      (b) False

**9. Moisture meters can give accurate readings above 28 percent MC.**

- (a) True                      (b) False

**10. The most valuable person in a treating plant is the plant operator.**

- (a) True                      (b) False

**Note:** Answers to these questions are at the end of the Program





# Lesson 7: The Wood-Treating Industry

## Introduction

This lesson indicates markets where demand for wood is greatest and looks at some trends in the treating industry.

## Wood Preservation Statistics: 1999 summary

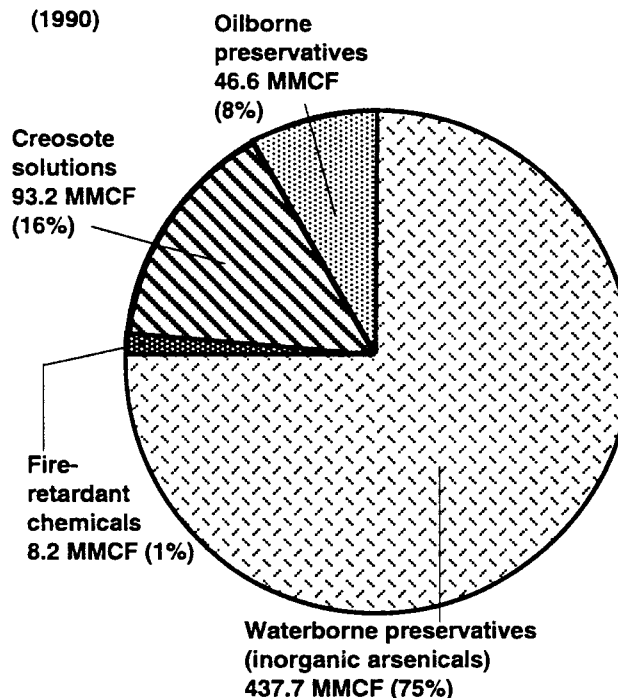
The following information is a summary of a report entitled “Wood Preservation Statistics, 1990,” prepared by James T. Mickle-Wright for the American Wood Preservers Association, copyright 1992. It is reprinted here with the permission of the AWP. This information is based on a survey of 540 treating plants that produced treated-wood products in 1990. To obtain a complete copy of Wood Preservation Statistics, 1990, contact the American Wood Preservers Association, P.O. Box 286, Woodstock, MD 21163-0286 or phone (410) 465-3169.

The study identified 540 wood-preserving plants that treated wood products in 1990. Of the total, 534 were pressure-treating plants and 6 were nonpressure treaters. These 540 treating plants were owned by 423 companies.

Based on production reports for 431 plants and estimates of production for 109 nonreporting plants, the industry treated 585.6 million cubic feet of wood products in 1990. See Figure 7.1.

The 1990 survey in contrast to earlier surveys provides a report on wood treated with oilborne preservatives other than pentachlorophenol. Nine plants reported volumes treated with copper naphthenate, zinc naphthenate, copper-8-quinolinolate and TBTO. A total of 1,051,388 cubic feet of wood was treated with these chemicals - two-thirds of it with copper naphthenate. This volume is reported under the heading “oilborne preservatives” and comprises about 2.6 percent of the total. More

Figure 7.1  
Volumes of wood treated with various chemicals  
(1990)



(MMCF = million cubic feet)

than 97 percent of the volume treated with oilborne preservatives was treated with pentachlorophenol.

The following categories of treated wood products (and associated volumes) were produced in 1990. See Figure 7.2, page 70. (Based on a total volume of 585.6 MMCF)

- Lumber and timbers: 375.6 MMCF (64.1%) or 6.4 billion board feet; 97.5% treated with waterborne preservatives.
- Crossties, switch and bridge ties: 70.2 MMCF (11.9%); all treated with creosote solutions.
- Poles: 73.5 MMCF (12.5%); 58.3% treated with oilborne preservatives, 23.7% treated with waterborne preservatives, 18% treated with creosote solutions.



- **Fenceposts:** 14.9 MMCF (2.5%)
- **Plywood:** 12.3 MMCF (2.1%) or 392.7 million sq. ft. (3/8" basis)
- **Pilings:** 7.2 MMCF (1.2%)
- **Other misc. products:** 30.7 MMCF (5.2%)

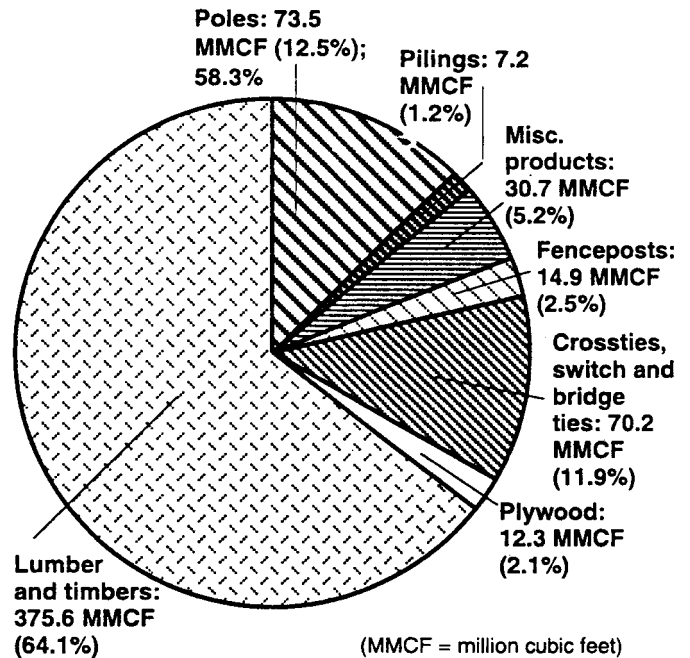
Total production in 1990 was up 5.2 percent over 1989 production, see **Table 7.1**. The year-to-year changes varied by type of treatments as follows:

- Volume treated with:
- Creosote solutions up 3.7% over 1989
  - Oilborne preservatives down 5.7% over 1989
  - Waterborne preservatives (inorganic arsenicals) up 7.6% over 1989
  - Fire-retardant chemicals down 23.9% over 1989

Production of treated poles in 1990 was essentially the same as in 1989. Volume of crossties, switch and bridge ties increased about 9 percent and production of treated lumber and timbers was up about 7 percent. Volume of treated fence posts increased 3.5 percent. These gains were partially offset by declines in volumes of treated crossarms, Southern pine accounted for 71 percent of the volume of all treated wood products, and 81 percent of the volume of all products except crossties, switch and bridge ties. Crossties, switch and bridge ties were 91.5 percent oak and mixed hardwoods.

Employment in production of treated wood products in 1990 was estimated to be 9,759. Based on factors derived from information supplied by respondents to the survey, the total treating chemicals consumed by 534 pressure-treating plants in 1990 is estimated as follows:

- 85 plants treating with creosote solutions consumed 72.8 million gallons of creosote and creosote-coal tar, and 9.1 million gallons of petroleum solvent.



- 65 plants treating with pentachlorophenol consumed 24 million pounds of penta and 31.1 million gallons of petroleum solvent.
- 458 plants treating with waterborne preservatives consumed 147.5 million pounds of preservative salts.
- 66 plants treating with fire retardants consumed 19.8 million pounds of fire retardant chemicals.

## Preservatives and Product Mix

Although no truly-new wood preservatives have come into widespread use for 20 or more years, there has been a shift in usage among the main three preservatives types: creosote, PCP in petroleum oils and CCA and other waterbornes. **See Table 7.1.**

Creosotes and PCP are losing markets to CCA primarily for lumber and timbers. The principal reasons for this shift are reduced demand for some traditional treated products such as crossties, higher prices and increasing environmental concern. Nearly all new treating plants being installed seem to favor the use of CCA or ACA preservatives.



**Table 7.1**  
**Trends in treatment of wood products, 1984–1990**

	1990	1989	1988	1987	1986	1985	1984
	<b>1,000 cubic feet</b>						
<b>Total volume treated:</b>	585,635	556,943	599,145	575,983	554,103	519,315	499,124
<b>Volume treated with:</b>							
Creosote	93,193	89,870	90,481	97,822	118,749	128,570	137,597
Penta	46,592	49,386	47,869	48,557	49,484	52,535	53,610
Waterborne	437,675	406,941	450,565	418,984	375,458	328,677	301,697
Fire retardants	8,176	10,746	10,230	10,618	10,412	9,532	6,223
<b>Volume by product:</b>							
Lumber	327,578	306,577	359,865	327,555	297,875	260,395	240,854
Timbers	<u>48,001</u>	<u>43,951</u>	<u>45,017</u>	<u>45,198</u>	<u>32,279</u>	<u>29,208</u>	<u>27,041</u>
Subtotal	375,579	350,528	404,882	372,753	330,154	289,603	267,895
Poles	73,501	73,975	71,191	75,274	73,341	76,831	77,658
Piling	7,186	9,678	9,699	8,120	10,482	10,529	11,839
Fenceposts	14,874	14,377	12,404	11,252	17,341	12,436	19,650
Crossties	62,988	58,022	57,770	59,594	80,443	85,894	88,720
Switch & bridge ties	7,165	6,301	6,315	9,306	5,907	8,134	8,198
Plywood	12,273	13,189	12,705	12,752	9,302	8,346	5,623
Other products <sup>1</sup>	32,072	30,873	24,179	26,932	27,133	27,540	19,541
	Number						
<b>Plants treating with:</b>							
Creosote	85	90	97	109	117	123	
Penta (Pressure, only)	65	60	65	71	81	97	
Waterborne	458	473	484	479	475	449	
Fire Retardants	66	71	80	81	79	77	
Total	534	553	576	581	588	567	

<sup>1</sup>Crossarms, landscape timbers, highway posts and guardrails, mine ties and timbers, crossing planks and other miscellaneous products not listed above.

Source: *Wood Preservation Statistics for respective years. Reports to the treating industry by J. T. Micklewright.*

The fast growth of CCA preservative use has been mainly the result of demand by the do-it-yourself (DIY) market. There has been a trend towards CCA use in place of creosote for poles, fencing and piling. Also, the number of creosoted crossties needed by the railroads for replacements is much less than when the railroads were expanding. This is a testament to the great success of creosote in preserving millions of crossties, thereby providing many years of safe, inexpensive and reliable service.

There has been a similar trend of PCP market loss to CCA treatments, but this has been countered somewhat by the introduction of water-dispersible forms of PCP. These forms eliminate or reduce the need for petroleum oils which, like all petroleum products, escalated in price in the 1970s, so the new forms of PCP are now being favored for some applications.



## New and Growing Uses for Treated Wood

### *Permanent wood foundations*

Replacement of the conventional concrete foundations for homes with *permanent wood foundations (PWFs)* was mentioned in Lesson 6. These were previously known as *all-weather wood foundations (AWWFs)*.

These foundations are of rigid box-like construction with treated lumber frames and treated plywood skins. They can be fabricated on site or in factories. When incorporated with moisture barriers, they provide reliable, dry basements for framed homes. PWFs can be erected quickly, can be installed in frost conditions unsuited to the setting of concrete and are approved for use by all the model building codes.

U.S. builders are making increased use of PWFs. Over 100,000 PWFs were said to be in use by late 1984. Lumber for this use requires kiln-drying, so production is only suited to treating plants with a kiln on site or readily available.

### *File foundations*

More use is also being made of piling as the rigid base for building in coastal, fresh water and low load-bearing (unstable) soil conditions. Many vacation homes are built on treated piles. Because of the serious consequence of decay in foundation piles, which are not easily replaced without drastic effect on the building, they are treated to high preservative retentions.

### *Do-if-yourself projects*

The DIY home and yard improvement market consumes large volumes of treated wood for a variety of uses such as:

- **Lumber:** for decking, framing, siding, walkways, jetties, fencing slats and rails, above-ground pools.
- **Posts:** for fencing, arbors, gazebos, carports.
- **Timbers:** for landscaping, pathways, playground equipment, retaining walls.

### *Aesthetic demands*

Until recently, treated wood was recognizable as a fairly rough, poorly finished, often dirty-looking commodity, which happened to be dark brown, green or natural colored, depending on the preservative used. Efforts are now underway to enhance the appearance of treated wood by improvements in surface cleanliness and color of the finished product.

**Surface cleanliness.** CCA-treated wood, especially, is subject to dark mold growth, which looks like dirt on the surface. Additives can now be included with the CCA at the treating plant that prevent mold growth and give a cleaner-looking, more attractive product.

**Color.** The availability of attractive brown shades of treated wood suitable for yard work without further coloring has also helped increase demand.

Competition in the preservation industry is forcing treaters to look not only at price and profit margins, but also at quality. Fewer defects, better surface finish, water-repellency, color and cleanliness are all part of on-going product improvements.



## Self-Testing Questions - Lesson 7

*(Some questions may have more than one answer)*

**1. Approximately how many wood treating plants are there in the U.S.?**

- (a) 650-675
- (b) 350-375
- (c) 525-575
- (d) 425-475

**2. In 1990 over 585 million cubic feet of wood was treated. Approximately what percentage of that volume was treated with waterborne preservatives?**

- (a) 50%
- (b) 95%
- (c) 85%
- (d) 75%

**3. Lumber and timbers account for what percentage of the total volume of treated wood products?**

- (a) 64%
- (b) 75%
- (c) 88%
- (d) 95%

**4. The next largest category of treated wood products after lumber is:**

- (a) Crossties
- (b) Poles
- (c) Timbers
- (d) Fenceposts

*NOTE Answers are given at the end of the program.*





# Lesson 8: Protecting Human Health and the Environment

## Introduction

This lesson is reprinted (with some modifications) from *Wood Preservation and Wood Products Treatment Training Manual*, EM 8403, September 1989, with permission of Oregon State University Extension Service.

Lesson 8 identifies the hazards that preservative applicators may be exposed to, discusses protective equipment for applicators, lists required precautions for end-users of treated wood and discusses why and how to protect the environment.

## Background

Most chemicals used to protect wood from insects and decay must be toxic to be effective. The challenge is to select chemicals and methods that will control the pests without harming the applicator, the user, the public, pets, plants or the environment.

It's the responsibility of the manager of any wood-preserving operation to ensure that proper handling procedures, protective clothing and necessary safety equipment are provided to workers to protect their health and to conform with label instructions.

The Environmental Protection Agency (EPA)-approved labeling and mandatory Material Safety Data Sheets for wood preservatives are the primary sources of information on application methods, precautionary measures, emergency first aid and disposal instructions. The label is a legal document and its provisions are enforced by state regulatory agencies. Therefore, make sure that labels for each formulated product used in a wood treatment operation are readily available and that all responsible personnel are thoroughly familiar with their contents.

## Hazards to Applicators

All handlers of wood preservatives must know about the potential hazards and the precautions necessary when working with these chemicals. Those who apply the chemicals are most subject to excessive exposure; those who use treated wood are at far less risk from preservative exposure. Therefore, it's especially important for those who apply preservatives and handle freshly-treated wood to minimize their exposure to these chemicals.

Exposure to wood preservatives can occur in a variety of ways: during mixing and handling of the chemicals, entering pressure-treatment cylinders, working around preservative spraying or dipping operations, handling freshly-treated wood, cleaning or repairing equipment or disposing of wastes. Closed systems for handling the chemicals and mechanical equipment for handling treated wood reduce potential exposure but do not eliminate accidental exposure to workers.

Like other pesticides, wood preservatives can enter the body through the mouth (oral contact), through the skin or eyes (dermal contact) or through inhalation (respiratory contact). Since most preservatives have a strong odor and taste, accidental ingestion of a dangerous amount of these chemicals is very unlikely. The more likely routes of exposure would be through skin contact or by inhaling preservative vapors, dust or other contaminated particles.

Human skin varies in thickness and other characteristics from one place to another on the body. The skin also varies in its ability to absorb chemicals. The eye, eyelids and the groin area will absorb almost 100 percent of some chemicals, whereas the hand, especially the palm, will absorb less than 10 percent of the same chemicals. The addition of organic



solvents to any preservative will enhance its ability to penetrate human skin.

Human lungs consist of a very large membranous surface area well supplied with blood vessels. Any chemical vapor or minute liquid droplets taken into the lungs will be absorbed into the bloodstream very rapidly.

## Toxic Effects of Preservatives

The toxic effects of a chemical can be either acute, based on high-level, short-term exposure, or chronic, based on low-level, long-term exposure. Human exposure to preservatives can produce both acute and chronic toxicity. EPA's decision to classify creosote, pentachlorophenol and inorganic arsenicals as *restricted use pesticides* was based on potential human health hazards associated with long-term, low-level exposure or chronic toxicity.

**Table 8.1** lists the toxicity effects, acute and chronic, of the three restricted use preservatives.

### *First Aid*

Since accidents do happen, first aid information on the chemical(s) in use must be readily available. The product label provides basic first aid directions, as do Material Safety Data Sheets supplied by the chemical manufacturers. **Table 8.2**, page 78, lists the first aid steps to be taken.

Take the following steps if accidental exposure to wood preservatives occurs:

- In case of skin contact, first remove contaminated clothing in contact with the skin and immediately wash the affected skin areas with mild soap and water. Don't irritate the skin with vigorous scrubbing. If you notice skin inflammation later, consult a physician.
- In cases of eye exposure, immediately flush the eyes with running water. Lift the upper and lower eyelids for complete irrigation and continue for 15 minutes, then see a physician.

- If accidental inhalation occurs, move the victim to fresh air and apply artificial respiration as needed. Get medical help immediately!
- Accidental ingestion of any wood preservative requires immediate medical attention. If penta was swallowed—and if the person is conscious—give 1 or 2 glasses of water, induce vomiting and then administer two tablespoons of “USP drug grade” activated charcoal in water. Never induce vomiting or attempt to administer anything orally to an unconscious person.
- If creosote or an arsenical chemical has been swallowed, the victim should drink large quantities of water or milk. Get professional medical help immediately!
- Acute toxicity symptoms for all three preservatives are usually noticed soon after exposure and are usually treatable if first aid is administered quickly.

## Protecting the Applicator

Anyone working with wood preservatives will be exposed to these chemicals to some extent but the exposure can be minimized by following the directions on the preservative label and developing good work habits.

### *Personal hygiene*

Basic commonsense hygiene rules can significantly reduce the risks of chronic exposure to wood preservatives.

- Wash hands often, especially before using the restroom, smoking or eating.
- Don't eat, drink or smoke in the work area—each of these activities will increase the amount of preservative absorbed into the body.
- Remove gloves to handle paperwork, phones or equipment that others may handle with unprotected hands.



Table 8.1  
Restricted-use pesticides creosote, pentachlorophenol and inorganic arsenicals: toxic effects (acute and chronic) and special precautions.

Pesticide	Toxic Effects		
	Acute	Chronic	Special Precautions
Creosote	<ul style="list-style-type: none"> <li>• Skin irritation, burns, or dermatitis.</li> <li>• Vapors irritating to eyes and respiratory tract.</li> <li>• Ingestion can cause nausea and abdominal distress.</li> </ul>	<ul style="list-style-type: none"> <li>• Laboratory animal studies indicate that it is a carcinogen (cancer-causing agent).</li> <li>• Has been associated with skin cancer in some occupationally exposed workers.</li> <li>• Bacteria and laboratory animal studies indicate that it is a mutagen (causes genetic defects).</li> </ul>	
Pentachlorophenol	<ul style="list-style-type: none"> <li>• Irritating to eyes, skin, and respiratory tract.</li> <li>• Ingestion or excessive dermal or inhalation exposure can lead to fever, headache, weakness, dizziness, nausea, and profuse sweating.</li> <li>• Prolonged high exposure levels can lead to acne-like skin condition or other skin disorders; may cause damage to the liver, kidneys, and nervous system.</li> </ul>	<ul style="list-style-type: none"> <li>• Considered a teratogen because it causes birth defects in laboratory animals.</li> <li>• A dioxin contaminant in penta has been shown to cause cancer in laboratory animals, although it's not the most toxic of the dioxins.</li> </ul>	<ul style="list-style-type: none"> <li>• When emptying or mixing prilled, powdered, or flaked formulations of this chemical, a closed system must be used.</li> <li>• When using the spray method of application, operate the spray apparatus to minimize visible mist. The apparatus must be free of leaks. When spray mist is in the work zone, workers must wear approved respirators, goggles and clothing impervious to the preservative formulation (including overalls, jacket, gloves, boots, and head covering).</li> </ul>
Inorganic Arsenicals	<ul style="list-style-type: none"> <li>• Exposure to high concentrations can cause nausea, headache, diarrhea, and abdominal pain (if ingested); extreme symptoms can progress to dizziness, muscle spasms, delirium and convulsions.</li> <li>* Prolonged exposure can produce persistent headaches, abdominal distress, salivation, low-grade fever, and upper respiratory irritation.</li> <li>• Long-term, high exposure can cause liver damage, loss of hair and fingernails, anemia, and skin disorders.</li> </ul>	<ul style="list-style-type: none"> <li>• Bacteria and laboratory animal studies indicate that it causes genetic defects.</li> <li>• Shown to be associated with cancer in people who either drink water or breathe air contaminated with arsenic.</li> </ul>	<ul style="list-style-type: none"> <li>• If the level of ambient arsenic in the work zone is unknown or if the level exceeds 10 micrograms per cubic meter of air averaged over an 8-hour work day, all exposed workers are required to wear approved respirators.</li> <li>• Processes used to apply inorganic arsenical formulations should leave no visible surface deposits on the wood. Small, isolated, or infrequent spots of chemical on otherwise clean wood are allowed.</li> </ul>



**Table 8.1**  
**Restricted-use pesticides creosote, pentachlorophenol and inorganic arsenicals: first aid.**

Pesticide	First Aid			
	Skin Contact	Eyes	Vapors	Ingestion
Creosote	<ul style="list-style-type: none"><li>• Wash with soap and water or waterless soap.</li><li>• Do not use solvents.</li><li>• Remove contaminated clothing</li></ul>	<ul style="list-style-type: none"><li>• Flush with water for at least 15 minutes.</li><li>• Consult physician.</li></ul>	<ul style="list-style-type: none"><li>• Move victim to fresh air.</li></ul>	<ul style="list-style-type: none"><li>• Obtain immediate medical assistance</li><li>• Do NOT induce vomiting. Give 1 glass of milk or 1 to 2 ounces of activated charcoal in water. Do not give if victim is unconscious.</li></ul>
Pentachlorophenol	<ul style="list-style-type: none"><li>• Wash with soap and warm water.</li><li>• Remove contaminated clothing.</li></ul>	<ul style="list-style-type: none"><li>• Flush with water for at least 15 minutes.</li><li>* Consult a physician.</li></ul>	<ul style="list-style-type: none"><li>• Move victim to fresh air.</li></ul>	<ul style="list-style-type: none"><li>• Obtain immediate medical assistance</li><li>• Induce vomiting, then take 2 table-spoons of activated charcoal in water.</li><li>• Never induce vomiting or attempt to force an unconscious person to drink.</li></ul>
Inorganic Arsenicals	<ul style="list-style-type: none"><li>• Flush with water.</li><li>• Remove contaminated clothing.</li></ul>	<ul style="list-style-type: none"><li>• Flush with water for at least 15 minutes.</li><li>• Consult a physician.</li></ul>	<ul style="list-style-type: none"><li>• Move victim to fresh air.</li></ul>	<ul style="list-style-type: none"><li>• Obtain immediate medical assistance</li><li>• Do NOT induce vomiting.</li><li>• Give 1 glass of milk or 1 to 2 ounces of activated charcoal in water. Do not give if victim is unconscious.</li></ul>



- Launder protective clothing at the work site. If work clothes must be laundered at home, wash them separately from other laundry.

### ***Protective clothing and equipment***

The pesticide label will specify the type of protective clothing and equipment that should be worn when working with wood preservatives. Where skin contact is expected (for example, handling freshly-treated wood or manually opening pressure-treatment cylinders), the label will specify the use of impermeable gloves.

Leather may protect hands from slivers, but leather gloves don't protect the wearer from wood preservatives! In fact, preservative-

contaminated leather gloves will definitely contribute to the amount of preservative absorbed into the body.

Individuals who enter pressure-treatment cylinders or other related equipment contaminated with wood-treatment solutions must wear protective equipment that does not allow the wood treatment solution to penetrate. This includes overalls, jacket, gloves, boots and respirator.

Respirators must be approved by the Mine Safety and Health Administration and the National Institute for Occupational Safety and Health (MSHA/NIOSH), and they must be properly fitted and maintained. See **Table 8.3** for special clothing and equipment for creosote, pentachlorophenol and arsenicals.

**Table 8.3**  
Recommended protective clothing and equipment.

Preservative	Acceptable glove materials	Acceptable clothing materials	Acceptable respirators
Creosote	Polyvinyl acetate (PVA); polyvinyl chloride (PVC); neoprene; NBR (Buna-N)	Neoprene; polyvinyl acetate (P V 4 Polyvinyl chloride (PVC); NBR (Buna-N)	MSHNNIOSH approved cartridge-type respirator that gives protection against organic vapors and polynuclear aromatics
Pentachlorophenol	Neoprene; polyvinyl acetate (PVA); polyvinyl chloride (PVC); NBR (Buna-N)	Neoprene (for entering cylinders); plastic-coated disposable coveralls impervious to dust (for dust protection); tightly woven natural or synthetic fiber clothing (cotton or polyester), covering full body (for working around treating plant)	MSHNNIOSH approved organic vapor and acid gas respirator; MSHN NIOSH self-contained breathing apparatus with full face piece (supplied air)
Inorganic Arsenicals	Vinyl; polyvinyl chloride (PVC); neoprene; NBR (Buna-N); rubber; polyethylene	Vinyl; polyvinyl chloride (PVC); neoprene; NBR (Buna-N); rubber; polyethylene	MSHNNIOSH approved half-mask supplied air respirator; Properly fitted well-maintained, high efficiency filtered respirators approved for inorganic arsenic



## Material Safety Data Sheets

*Material Safety Data Sheets (MSDS)* are available from the manufacturers and distributors of the wood preservatives they sell. Each MSDS provides information about the toxicity, first aid, protective equipment, storage and handling precautions, disposal procedures and transportation for a specific product. All wood treaters should have an **MSDS** on file for each different formulation they use.

## Voluntary Consumer Awareness Program

The treated wood industry has developed a voluntary *Consumer Awareness Program (CAP)* designed to inform consumers about the proper uses of treated wood and the proper precautionary measures to take when using such wood. The treated wood industry is committed to the implementation of the CAP and the education of the consuming public.

The treated wood industry has developed a model *Consumer Information Sheet (CIS)* containing use site or application precautions and safe working practices for each of the three types of preservatives. The CIS serves as the main vehicle for conveying information about treated wood to consumers. The focus of the CAP is to ensure the dissemination of the CIS at the time of sale or delivery to end users. Wood treaters assume primary responsibility for dissemination of the CIS to the consumers. Examples of the consumer information sheets for the three restricted use chemicals can be found on pages 81-83.

## Protecting the Environment

### *Waste disposal*

Wastes from preservative-treating operations can kill plant life and harm aquatic life if they are allowed to enter waterways. Oils and organic solids damage aquatic life by reducing oxygen supplies.

Some treating plants discharge their wastes into approved municipal sewer systems for processing along with municipal wastes.

Many plants use closed chemical and wastewater recovery systems to contain wastes that could be harmful. Recovered solutions may be used again. If they are contaminated, they can be filtered to remove solid wastes. Liquid waste materials may be diverted to settling ponds.

Floor sumps should be used under pressure-chamber doors and under hard-surfaced drainage areas. Any excess chemicals that drip or are rinsed from freshly-treated material are thus channeled into the waste or recovery system. It is also important to contain the runoff from areas where toxic chemicals are used to protect stored logs, poles or lumber before processing or during seasoning.

Remember to read the preservative label carefully for disposal information. The U.S. Environmental Protection Agency requires treatment facilities to meet certain disposal standards. EPA also requires that treatment plants obtain permits for discharging excess chemicals. Compliance with the label and EPA regulations should assure proper environmental protection.

### *Storage and disposal of containers*

Packaged chemicals should be stored in a dry, well-ventilated, securely-locked area. Keep them in well-sealed containers whenever possible. Protect liquid storage against tank rupture. Wherever spills, leaks or flooding could occur, be sure that runoff will drain into a recovery or disposal system.

Protect concrete vats against freezing, cracking or spillage. Thoroughly rinse containers and empty them into storage or treating tanks before disposal. Dispose of the containers at an approved landfill or by other approved means. Be particularly careful not to contaminate streams or ground water.

Be sure to read and follow the label requirements and the Material Safety Data Sheet for each preservative. If you're in doubt about how to safely store a product or dispose of the empty containers, contact the chemical supplier or your state agency that regulates storage and container disposal.



## Consumer Information Sheet for Wood Pressure-treated with Creosote

### **Consumer information:**

This wood has been preserved by pressure treatment with an EPA-registered pesticide containing creosote to protect it from insect attack and decay. Wood treated with creosote should be used only where such protection is important.

Creosote penetrates deeply into and remains in the pressure-treated wood for a long time. Exposure to creosote may present certain hazards; therefore, the following precautions should be taken both when handling treated wood and in determining where to use the treated wood.

### **Precautions: Use site or application**

- Wood treated with creosote should not be used where it will be in frequent or prolonged contact with bare skin (for example, chairs and other outdoor furniture) unless an effective sealer has been applied.
- Creosote-treated wood should not be used in residential interiors. Creosote-treated wood in interiors of industrial buildings should be used only for industrial building components that are in ground contact and are subject to decay or insect infestation and woodblock flooring. For such uses, two coats of an appropriate sealer must be applied. Sealers may be applied at the installation site.
- Wood treated with creosote should not be used in the interiors of farm buildings where there may be direct contact with domestic animals or livestock which may crib (bite) or lick the wood.
- In interiors of farm buildings where domestic animals or livestock are unlikely to crib (bite) or lick the wood, creosote-treated wood may be used for building components that are in ground contact and are subject to decay or insect infestation if two coats of an effective sealer are applied. Sealers may be applied at the installation site.
- Do not use creosote-treated wood for farrowing or brooding facilities.
- Do not use treated wood under circumstances where the preservative may become a component of food or animal feed. Examples of such use would be structures or containers for storing silage or food.
- Do not use treated wood for cutting boards or countertops.
- Only treated wood that is visibly clean and free of surface residues should be used for patios, decks and walkways.

- Do not use treated wood for construction of those portions of beehives that may come into contact with the honey.
- Creosote-treated wood should not be used where it may come into direct or indirect contact with public drinking water, except for uses involving incidental contact such as docks and bridges.
- Do not use creosote-treated wood where it may come into direct or indirect contact with drinking water for domestic animals or livestock, except for uses involving incidental contact such as docks and bridges.

### **Handling precautions**

- Dispose of treated wood by ordinary trash collection or burial. Treated wood should not be burned in open fires or in stoves, fireplaces or residential boilers, because toxic chemicals may be produced as part of the smoke and ashes. Treated wood from commercial or industrial use (for example, construction sites) may be burned only in commercial or industrial incinerators or boilers in accordance with state and federal regulations.
- Avoid frequent or prolonged inhalation of sawdust from treated wood. When sawing and machining treated wood, wear a dust mask. Whenever possible, these operations should be performed outdoors to avoid indoor accumulations of airborne sawdust from treated wood.
- Avoid frequent or prolonged skin contact with creosote-treated wood; when handling the treated wood, wear long-sleeved shirts and long pants and use gloves impervious to the chemicals (for example, gloves that are vinyl coated).
- When power-sawing and machining, wear goggles to protect eyes from flying particles.
- After working with the wood, and before eating, drinking or using tobacco products, wash exposed areas thoroughly.
- If oily preservative or sawdust accumulate on clothes, launder before reuse. Wash work clothes separately from other household clothing.
- Coaltar pitch and coaltar pitch emulsion are effective sealers for creosote-treated wood-block flooring. Urethane, epoxy and shellac are acceptable sealers for all creosote-treated wood.



## Consumer Information Sheet for Wood Pressure-treated with Pentachlorophenol

### **Consumer information:**

This wood has been preserved by pressure treatment with an EPA-registered pesticide containing pentachlorophenol to protect it from insect attack and decay. Wood treated with pentachlorophenol should be used only where such protection is important.

Pentachlorophenol penetrates deeply into and remains in the pressure-treated wood for a long time. Exposure to pentachlorophenol may present certain hazards; therefore, the following precautions should be taken both when handling treated wood and in determining where to use the treated wood.

### **Precautions: Use site or application**

- Logs treated with pentachlorophenol should not be used for log homes.
- Wood treated with pentachlorophenol should not be used where it will be in frequent or prolonged contact with bare skin (for example, chairs and other outdoor furniture), unless an effective sealer has been applied.
- Pentachlorophenol-treated wood should not be used in residential, industrial or commercial interiors except for laminated beams or building components that are in ground contact and are subject to decay or insect infestation. For such uses two coats of an appropriate sealer must be applied. Sealers may be applied at the installation site.
- Wood treated with pentachlorophenol should not be used in the interiors of farm buildings where there may be direct contact with domestic animals or livestock which may crib (bite) or lick the wood.
- In interiors of farm buildings where domestic animals or livestock are unlikely to crib (bite) or lick the wood, pentachlorophenol-treated wood may be used for building components that are in ground contact and are subject to decay or insect infestation, if two coats of an appropriate sealer are applied. Sealers may be applied at the installation site.
- Do not use pentachlorophenol-treated wood for farrowing or brooding facilities.
- Do not use treated wood under circumstances where the preservative may become a component of food or animal feed. Examples of such sites would be structures or containers for storing silage or food.

- Do not use treated wood for cutting boards or countertops.
- Only treated wood that is visibly clean and free of surface residue should be used for patios, decks and walkways.
- Do not use treated wood for construction of those portions of beehives that may come into contact with the honey.
- Pentachlorophenol-treated wood should not be used where it may come into direct or indirect contact with public drinking water, except for uses involving incidental contact such as docks and bridges.

### **Handling precautions**

- Dispose of treated wood by ordinary trash collection or burial. Treated wood should not be burned in open fires or in stoves, fireplaces or residential boilers because toxic chemicals may be produced as part of the smoke or ashes. Treated wood from commercial or industrial use (for example, construction sites) may be burned only in commercial or industrial incinerators or boilers rated at 20 million BTU/hour or greater heat input or its equivalent in accordance with state and federal regulations.
- Avoid frequent or prolonged inhalation of sawdust from treated wood. When sawing and machining treated wood, wear a dust mask. Whenever possible, these operations should be performed outdoors to avoid indoor accumulations or airborne sawdust from treated wood.
- Avoid frequent or prolonged skin contact with pentachlorophenol-treated wood; when handling the treated wood, wear long-sleeved shirts and long pants and use gloves impervious to the chemicals (for example, gloves that are vinyl-coated).
- When power-sawing and machining, wear goggles to protect eyes from flying particles.
- After working with the wood, and before eating, drinking or using tobacco products, wash exposed areas thoroughly.
- If oily preservatives or sawdust accumulate on clothes, launder before reuse. Wash work clothes separately from other household clothing.
- Urethane, shellac, latex epoxy enamel and varnish are acceptable sealers for pentachlorophenol-treated wood.



## Consumer Information Sheet for Wood Pressure-treated with Inorganic Arsenicals

### **Consumer Information:**

This wood has been preserved by pressure treatment with an EPA-registered pesticide containing inorganic arsenic to protect it from insect attack and decay. Wood treated with inorganic arsenic should be used only where such protection is important.

Inorganic arsenic penetrates deeply into and remains in the pressure-treated wood for a long time. Exposure to inorganic arsenic may present certain hazards; therefore, the following precautions should be taken when handling the treated wood, in determining where to use the wood, and in disposing of the treated wood.

### **Precautions: Use site or application**

- Wood pressure-treated with waterborne arsenical preservatives may be used inside residences as long as all sawdust and construction debris are cleaned up and disposed of after construction.
- Do not use treated wood under circumstances where the preservative may become a component of food or animal feed. Examples of such sites would be structures or containers for storing silage or food.
- Do not use treated wood for cutting boards or countertops.
- Only treated wood that is visibly clean and free of surface residue should be used for patios, decks and walkways.
- Do not use treated wood for construction of those portions of beehives that may come into contact with the honey.

- Treated wood should not be used where it may come into direct or indirect contact with public drinking water, except for uses involving incidental contact such as docks and bridges.

### **Handling precautions**

- Dispose of treated wood by ordinary trash collection or burial. Treated wood should not be burned in open fires or in stoves, fireplaces or residential boilers because toxic chemicals may be produced as part of the smoke and ashes. Treated wood from commercial or industrial use (for example, construction sites) may be burned only in commercial or industrial incinerators or boilers in accordance with state and federal regulations.
- Avoid frequent or prolonged inhalation of sawdust from treated wood. When sawing and machining treated wood, wear a dust mask. Whenever possible, these operations should be performed outdoors to avoid indoor accumulations of airborne sawdust from treated wood.
- When power-sawing and machining, wear goggles to protect eyes from flying particles.
- After working with the wood, and before eating, drinking or using tobacco products, wash exposed areas thoroughly.
- If preservatives or sawdust accumulate on clothes, launder before reuse. Wash work clothes separately from other household clothing.

### **spills**

Correct cleanup procedures depend on the chemical involved. Treating-plant personnel should know what chemicals are being stored and used, and they should have an advance plan for handling spills. All workers who might be involved should know what help is available and who to notify in case of a major spill.

### **Environmentalexposure**

It's not only people who can suffer from the careless use or disposal of wood preservatives—you community's environment may also suffer. Creosote, pentachlorophenol and inorganic arsenicals are toxic. They must be

toxic to kill or repel the fungi, insects and marine borers that destroy wood. Unfortunately, these chemicals are not selective; they can harm non-target organisms.

Contaminated runoff can pollute lakes, streams and wetlands, thereby damaging habitat for fish and wildlife. Specifics vary, but penta, creosote and inorganic arsenicals are all toxic to fish and other wildlife.

Creosote—There are no recorded reports of wild or domestic animals being injured by creosote. The amount of creosote that enters the environment as a liquid is relatively small. The fate of creosote in the environment isn't known, but most of its components are quickly biodegraded.



**Pentachlorophenol** — This chemical is not uncommon in the aquatic environment and is extremely toxic to fish. Exposure to penta concentrations in the parts-per-billion range can cause death within minutes for many species of salmon and trout. Penta is moderately persistent in the aquatic environment. It was reportedly detected in lakewater and fish six months after an accidental spill.

Circumstantial evidence, including the identification of penta in rainwater, indicates that penta may occasionally be present in ambient air. Low levels of this compound have been detected in both wastewater and surfacewater. While the source of these residues is often unclear, it's been suggested that, in addition to direct contamination of water by penta, degradation of other organic compounds or chlorination of water may result in the chemical production of penta.

Penta is also moderately persistent in soil. Persistence reportedly ranges from 21 days to 5 years. Under most conditions, penta will seldom persist in the soil for periods exceeding 9 months because many soil microorganisms have been identified that are capable of degrading penta. Since the major uses of penta don't involve applying it to the soil, the likeliest source of soil contamination is the leaching or bleeding of the preservative from treated wood. This may result in low levels of penta contamination in the immediate vicinity of the treated wood.

Significant accumulation of penta in plants and mammals is not likely to occur because penta is not translocated in plants, and it's rapidly eliminated by mammals following exposure.

**Arsenicals** – No problems have ever been found in the literature as to the effects of arsenical wood preservatives on the environment. Arsenate, the form present in aerobic soils, is bound tightly to the soil components and becomes unavailable for plant uptake or leaching.

### ***Groundwater pollution***

Use of wood preservatives over the years has been cited as the source of pollution in surface and groundwater in many parts of this country. Some of this problem has come from obvious sources such as spills or illegal discharge of chemicals into ditches, storm drains or sewers. Another less obvious source of the pollutants is the uncontained drippings from freshly-treated wood.

Although preservative pollution of surfacewater is more obvious and can be a serious problem, groundwater pollution is potentially a very serious problem. In many communities, groundwater is the only source of drinking water. When groundwater becomes contaminated with any chemical, cleanup — where possible — is very difficult and costly. Testing has documented contamination in public and private wells at levels exceeding health advisories.

Groundwater is typically affected by contamination of the overlying soil. Such contamination is usually the result of overflow from tanks or holding ponds and improper disposal. To reduce the chance of environmental contamination, proper protective measures must be an integral part of all your wood preservation operations.

## Self-Testing Questions - Lesson 8

(Some questions may have more than one answer)

**1. Wood preservatives can enter the body through oral, dermal or respiratory contact.**

- (a) True                      (b) False

**2. Acute toxicity is based on low-level, long-term exposure.**

- (a) True                      (b) False

**3. Exposure to high concentrations of inorganic arsenicals can cause what type of symptoms?**

- (a) Nausea                      (b) Headache  
(c) Diarrhea                      (d) Dizziness  
(e) Muscle spasms                      (f) Convulsions  
(g) All of the above

**4. Long-term exposure to inorganic arsenicals could result in cancer or genetic defects.**

- (a) True                      (b) False

**5. If a person ingests (drinks) CCA, what first aid should be given?**

- (a) Induce vomiting if conscious  
(b) Do not induce vomiting if conscious  
(c) Call a doctor  
(d) Give 1 glass of milk  
(e) Give 1 or 2 ounces of activated charcoal in water

**6. Leather gloves provide adequate protection when handling wood preservatives.**

- (a) True                      (b) False

**7. Which of the following safety precautions should be followed when handling wood preservative chemicals?**

- (a) Do not eat, drink or use tobacco when handling  
(b) Wash thoroughly after skin contact  
(c) Wear gloves impervious to formulation  
(d) All of the above

**8. Workers handling inorganic arsenicals for the pressure treatment of wood must either wear a properly fitted and approved respirator, or have an approved monitoring program.**

- (a) Yes                      (b) No

**9. Rubber is an acceptable glove material for handling inorganic arsenicals.**

- (a) True                      (b) False

**10. Goggles and a dust mask should be worn whenever sawing or machining treated wood.**

- (a) True                      (b) False

**11. Wood treated with creosote or penta can be used anywhere inside farm buildings without restrictions.**

- (a) True                      (b) False

**12. Groundwater contamination can be caused by the uncontained drippings from freshly-treated wood.**

- (a) True                      (b) False

**Note;** Answers to these questions are at the end of the program.





# Answers to Self-Test Questions

## Lesson 1

- 1) d
- 2) F
- 3) T
- 4) c & f
- 5) c
- 6) a & c
- 7) a, c, f, h, i
- 8) d
- 9) b
- 10) d
- 11) d
- 12) c
- 13) a
- 14) a

## Lesson 2

- 1) b
- 2) a
- 3) d
- 4) F
- 5) T
- 6) F
- 7) T
- 8) c & d
- 9) b, c, d, e
- 10) b
- 11) a

## Lesson 3

- 1) c
- 2) T
- 3) c
- 4) T
- 5) b & d
- 6) F
- 7) F
- 8) a
- 9) d
- 10) b & d
- 11) a

## Lesson 4

- 1) e
- 2) a, b, d
- 3) b, c, d
- 4) b
- 5) c
- 6) d
- 7) b
- 8) d
- 9) a & b
- 10) a & d
- 11) c & d
- 12) b & d
- 13) a & d

## Lesson 5

- 1) b
- 2) a
- 3) a
- 4) c
- 5) b
- 6) b & d
- 7) a
- 8) c
- 9) a
- 10) d

## Lesson 6

- 1) c, f, l, m
- 2) F, F, T, F, T
- 3) a, b
- 4) e
- 5) F
- 6) F
- 7) T
- 8) T
- 9) F
- 10) T

## Lesson 7

- 1) c
- 2) d
- 3) a
- 4) b

## Lesson 8

- 1) T
- 2) F
- 3) g
- 4) T
- 5) b, c, d, e
- 6) F
- 7) d
- 8) a
- 9) T
- 10) T
- 11) F
- 12) T





# Glossary of Wood Preservation Terms

**Introduction:** Most of the terms encountered in this manual are listed and defined in this glossary. A number of additional terms commonly used by wood treaters have been excerpted, with permission, from the AWWA Standard M5-92. For wood preservation terms not found in this glossary, please see AWWA Standard M5-92, which contains an extensive list of terms, or contact the cooperative extension service in your area.

<b>Absorption force</b>	A physical force created by surface tension that causes plant or animal cells to take up water or other liquids.	<b>Air dried</b>	Seasoned by exposure to the air in a yard or shed without artificial heat until the wood has reached an approximate EMC with the surrounding air.
<b>Absorption, gross</b>	Total amount of preservative solution ingredients indicated in the wood at the termination of the pressure period; includes initial absorption and injection under pressure.	<b>ALSC</b>	American Lumber Standards Committee.
<b>Absorption, initial</b>	The amount of preservative absorbed by the wood during any preliminary heating or boiling under vacuum period, and also that absorbed by the wood while the cylinder is being filled prior to the pressure period.	<b>Ambrosia beetle</b>	A wood-boring insect that lives in green wood.
<b>Absorption, net</b>	See Retention by gauge.	<b>Ammonia</b>	Combined with water and used as a carrier or solvent for ACA and penta treatments.
<b>ACA</b>	Ammoniacal copper arsenate preservative.	<b>Ammonium salts</b>	A chemical used as a fire retardant treatment (FRT).
<b>ACC</b>	Acid copper chromate preservative.	<b>Angiosperms</b>	The botanical name for hardwood trees; means "seeds enclosed in a fruit or nut."
<b>Actual dimensions</b>	The true size of timber products in feet or inches as opposed to nominal size.	<b>Annual ring</b>	The growth layer put on by a tree in a single growth year, including both earlywood (springwood) and latewood (summerwood). Also called growth ring.
<b>ACZA</b>	Ammoniacal copper zinc arsenate preservative.	<b>Anobiid</b>	A powderpost beetle of the family Anobiidae.
<b>Adsorption force</b>	A chemical force that attracts and bonds water molecules to cellulose and other molecules.	<b>Antimony oxides</b>	A chemical used as a fire retardant treatment (FRT).
		<b>Arsenic pentoxide</b>	The form of arsenic salt found in CCA and ACA formulations.
		<b>Arsenicals</b>	Preservatives containing arsenic.



<b>Assay</b>	Determination, by appropriate physical and chemical means, of the amount of preservative or fire retardant in a sample of treated wood, usually expressed in pounds per cubic foot (pcf) or kilograms per cubic meter (kg/m <sup>3</sup> ).	<b>Bloom(ing)</b>	The formation of crystals on the surface of treated wood as a result of sublimation, exudation and subsequent evaporation of the solvent or water component of the preservative or fire retardant solution.
<b>Assay zone</b>	The portion of a wood product where test samples (borings) will be taken to determine preservative penetration and retention.	<b>Blue stain</b>	A bluish discoloration on fresh-sawn lumber products caused by stain fungi.
<b>Atmospheric pressure</b>	The force or pressure of the air that surrounds us. At sea level, atmospheric pressure averages 15 psi.	<b>Boards</b>	Lumber up to (but not including) 2" thick.
<b>AWPA</b>	American Wood Preservers Association.	<b>Borates</b>	A chemical used as a fire retardant treatment (FRT) and also as a preservative for some millwork products.
<b>AWPB</b>	American Wood Preservers Bureau.	<b>Borers, marine.</b>	Marine organisms which attack wood in the submerged portions of structures placed in salt or brackish waters. Two general groups of borers are recognized: the crustaceans ( <i>Limnoria</i> , <i>Chelura</i> , <i>Sphaeroma</i> ) and the molluscans ( <i>Teredo</i> , <i>Bankia</i> , <i>Martesia</i> ).
<b>AWPI</b>	American Wood Preservers Institute.	<b>Boulton drying process</b>	A process for drying wood consisting of holding the wood in a hot preservative treating liquid under a vacuum at a temperature and pressure so as to vaporize the water in the system; the water vapor is condensed outside the system. Also called Boultonizing.
<b>AWWF</b>	All-weather wood foundation; same as PWF.	<b>Bound water</b>	Water tied up in wood cell walls.
<b>Bankia</b>	One of three principal genera of molluscan (marine) borers.	<b>Boxed heart</b>	Descriptive of ties and timbers in which the pith falls entirely within the four faces anywhere in the length of the piece.
<b>Bark</b>	The outer protective layer of a tree.		
<b>Basic building code</b>	One of the three model building codes used in the US. Written by the Building Officials and Code Administrators International, Inc. (BOCA).		
<b>Bethell process</b>	Patented in 1838 by John Bethell. Same as full cell process.		
<b>Biological degradation</b>	Destruction of wood from attack by fungi, insects or marine borers.		



<b>Bromides</b>	A chemical used as a fire retardant treatment (FRT).	<b>CCA</b>	Chromated copper arsenate preservative.
<b>Brown rot</b>	Any wood decay in which the fungi primarily break down the cellulose, leaving a brown, easily crushed residue of lignin; sometimes loosely called "dry rot."	<b>Cell</b>	An individual unit of a plant.
<b>Building codes</b>	Codes that dictate the conditions under which treated wood must be used.	<b>Cell wall</b>	The outer part of a cell, divided into primary and secondary cell wall.
<b>Butt treatment</b>	Treatment applied to the lower or butt end of posts or poles, including only that portion that will be in the ground.	<b>Cellulose</b>	The main building material of all plant cells, made of long chains of glucose molecules.
<b>Cambium</b>	The thin layer of reproductive tissue between the phloem and sapwood that creates new phloem and sapwood cells.	<b>Charge</b>	All the wood treated together in one cylinder or treating tank at one time.
<b>CAP</b>	Consumer Awareness Program, designed by the treating industry to inform consumers about the proper usage and safe handling of treated wood products.	<b>Check</b>	A separation along the grain of the wood, the separation occurring across the annual rings.
<b>Capillary force</b>	Force that draws liquid into cells.	<b>Chemical reagent</b>	A chemical that can be sprayed on treated wood samples (or cores) that reacts with the preservative to show its presence clearly.
<b>Carpenter ants</b>	A type of ant that attacks wood to use as a shelter rather than for food.	<b>Chemical stains</b>	Wood discolorations resulting from chemical changes caused by bacteria or enzymes during seasoning; not caused by fungi.
<b>Carpenter bees</b>	A type of bee that lays eggs in holes chewed in wood.	<b>Chemonite</b>	A trade name for ammoniacal copper arsenate (ACA).
<b>Case hardened</b>	Refers to lumber products that exhibit residual drying stresses after drying is completed.	<b>Chromium trioxide</b>	The form of chromium salt used in CCA formulations.
<b>Caste</b>	Types of termites and ants, e.g., workers, soldiers, reproductive adults.	<b>CIS</b>	Consumer Information Sheet containing use site precautions and safe handling practices for wood preservatives. Available at time of sale or delivery.
		<b>Coal tar creosote</b>	A distillate of coal tar produced by the high-temperature carbonization of bituminous coal.



<b>Cold soak treatment</b>	Partial or full-length treatment of wood by soaking for varying periods of time in open vats containing an unheated, low-viscosity preservative oil at atmospheric temperature.	<b>Core</b>	The cylinder of wood, removed by means of an increment borer, from which may be determined, by linear measurement, sapwood thickness and preservative penetration, and, by assay, preservative retention and distribution.
<b>Compression wood</b>	Abnormal wood that often forms on the lower side of branches and inclined trunks of coniferous trees. It is characterized by: (a) relatively wide annual rings, usually eccentric; (b) summerwood frequently more than 50 percent of the annual rings in which it occurs; (c) little contrast in color between springwood and summerwood; (d) excessive longitudinal shrinkage in comparison to normal wood.	<b>Creosote</b>	A generic term applied to certain distillates of tars. As used in the wood-preserving industry, the unmodified term creosote denotes coal tar creosote. See Creosote, coal tar.
<b>Conditioning</b>	The heating and removal of moisture from unseasoned or partially seasoned wood as a preliminary to preservative treatment and as a means of improving the penetrability and absorptive properties of wood.	<b>Creosote, coal tar</b>	A distillate derived from coal tar. As used in the wood preserving industry, creosote denotes a distillate of coal tar produced by the high- temperature carbonization of bituminous coal. Creosote consists principally of liquid and solid aromatic hydrocarbons and contains some tar acids and tar bases; it is heavier than water and has a continuous boiling range beginning at about 200°C.
<b>Conifer</b>	Another name for softwood trees; means "cone bearing."	<b>Cross-sectional face</b>	Another name for the transverse surface or end-grain surface of wood.
<b>Copper-8 quinolinolate</b>	The only preservative-accepted by the FDA for wood products such as bins or pallets that may come in direct contact with food products.	<b>Crustacean borer</b>	A type of marine borer (related to shrimp) that chews away the surface of unprotected wood structures in saltwater.
<b>Copper naphthenate</b>	A petroleum oil-soluble copper soap complex made from naphthenic acids having an acid value of at least 180.	<b>Cylinder, treating</b>	A steel tank, commonly horizontal, one or both ends of which may be opened and closed, in which wood is placed for treatment usually by a pressure process with a preservative, fire retardant or other material. Also called Retort.
<b>Copper oxide</b>	The form of copper salt used in CCA formulations.		



<b>Decay</b>	Decomposition of wood substance by wood-destroying fungi. Two stages of decay are ordinarily recognized: The <i>incipient</i> and <i>advanced</i> stages. Syn. rot, dote, doze.	<b>Dual treatment</b>	A treating process using two preservatives, such as CCA and creosote, in separate treatments to provide adequate protection to marine structures.
<b>Decay, advanced</b>	A stage of decay in which the wood has become definitely changed in appearance, character, composition, hardness and specific gravity.	<b>Durability</b>	As applied to wood, its lasting qualities or permanence in service, with reference to its resistance to decay and other forms of deterioration. Decay resistance is a somewhat more specific term, indicating resistance to attack by wood-destroying fungi under conditions favorable to their growth.
<b>Decay fungi</b>	Fungi that feed on cellulose and lignin and cause wood to rot.	<b>Earlywood</b>	The less dense, larger-celled, first-formed part of a growth layer. Syn. springwood.
<b>Decay, incipient</b>	An early stage of decay in which the wood may show discoloration but is not otherwise visibly altered, although some of its properties may have deteriorated appreciably.	<b>EMC</b>	Equilibrium moisture content; the moisture content of wood when it is in balance with the relative humidity of the surrounding air.
<b>Deciduous</b>	Refers to trees that drop their leaves in the fall, which includes almost all the hardwoods.	<b>Empty cell process</b>	A treatment in which air imprisoned in the wood is employed to force out part of the preservative when treating pressure is released and a final vacuum is applied. It permits deep penetration of preservative while controlling the loading or retention of preservative in the wood cells. See Lowry and Rueping process.
<b>Dimension lumber</b>	Lumber that is nominally 2" up to, but not including, 5" in thickness.	<b>Enzyme</b>	A type of protein produced by living organisms (such as fungi) that acts as a catalyst to break down chemicals (such as cellulose) into usable sugars.
<b>Dote</b>	See Decay.		
<b>Double treatment</b>	Application during any given treatment (charge) of two distinct pressure phases to increase penetration of preservative (also called double press).		
<b>Doze</b>	See Decay.		
<b>Dry rot</b>	A term loosely applied to any dry, crumbly rot. The term is actually a misnomer since all fungi require considerable moisture for growth. See Brown rot.		



<b>Extractives</b>	Various organic and inorganic substances, which are by-products of the chemical changes that take place in living tissues.	<b>Full cell (Bethell) process</b>	The most common vacuum-pressure process, which gives the deepest penetration and highest retentions.
<b>Fiber saturation point</b>	Point where cell cavity contains no free water but cell wall still contains bound water; occurs at about 30% MC for most woods.	<b>Fungi</b>	Spore-producing organisms that derive metabolic nourishment from living or dead host tissue, rather than through photosynthesis.
<b>Field treatment</b>	Brush or spray application of approved preservatives to cut ends, drilled holes, or other newly exposed surfaces of pressure treated wood.	<b>Gallery</b>	Tunnels made in wood by wood-boring beetles.
<b>Fire retardant treatment</b>	See FRT	<b>Glucose</b>	A molecule that links together in long strands to form cellulose and hemicellulose.
<b>Fire retardant</b>	A chemical, chemical mixture or coating whose proper application to wood substantially increases its resistance to flaming or burning.	<b>Grade mark</b>	Identification of lumber with symbols or lettering to certify its quality of grade, which is based on the presence or absence of defects, such as knots, checks, decay, etc.
<b>Fixation period</b>	That period in which substantially all of the active chemicals retained in the wood are fixed.	<b>Green weight</b>	The weight of wood when freshly cut; includes the weight of the wood and the weight of the water in the wood.
<b>Flatheaded borer</b>	A type of wood-boring beetle that mines trees and lumber.	<b>Greenheart</b>	A very hard and very durable tropical hardwood tree.
<b>Foundation use</b>	Forest products intended for use in permanent wood foundations in commercial or residential construction.	<b>Gribbles</b>	Another name for limnoria (crustacean borers).
<b>Frass</b>	Powdery undigested particles of wood left by powderpost beetles.	<b>Ground contact use</b>	Pressure-treated forest products intended for use in, or in contact with, the ground, soil or fresh water.
<b>Free water</b>	Water found inside wood cell cavities.	<b>Growth layer</b>	The layer of wood produced in one growing season including earlywood and latewood. See Annual ring.
<b>FRT</b>	Fire retardant treatment. A formulation used to increase wood's resistance to flaming or burning.		



<b>Gymnosperm</b>	The botanical term for softwood trees; means "trees that produce naked seeds."	<b>Increment borer</b>	An auger-like instrument with a hollow bit and equipped with an extractor used to sample wood internally without destroying the piece. The core obtained serves to measure sapwood thickness and depth of penetration. Likewise the borer is used to obtain sample cores of treated wood at specified depths (zones) for the determination of preservative retention by assay or by toluene extraction.
<b>Hardwood</b>	Refers to the broadleaved trees botanically called angiosperms. Does not refer to the wood's density.	<b>Inner bark</b>	The phloem layer; the layer that conducts nutrients up and down the trunk.
<b>Heartwood</b>	The inner portion of a woody stem, extending from pith to sapwood, composed entirely of nonliving cells and usually differentiated from the outer enveloping layer of sapwood by its darker color.	<b>Kick-back</b>	Amount of preservative forced out of the treated wood when the pressure is reduced below the initial pressure.
<b>Hemicellulose</b>	A chemical component of wood made of glucose and other sugars.	<b>Kiln drying</b>	Drying in a building with controlled heat, humidity and air circulation.
<b>Hot-and-cold process</b>	Thermal process of treating wood with hot preservative, then cold solution.	<b>Kiln dried</b>	Lumber or other materials that have been dried in dry kilns to a moisture content usually below that obtained in air-drying.
<b>Hygroscopic</b>	Sensitive or responsive to moisture in the air.	<b>Latewood</b>	The denser, smaller-celled, later-formed part of the growth layer. Syn. autumnwood, summerwood.
<b>Hyphae</b>	Threadlike fungal strands that grow throughout wood, digesting parts of the wood as food.	<b>Lignin</b>	A complex chemical that helps cement cellulose, microfibrils and cells together. Lignin makes it possible for trees and shrubs to grow tall by making the cellular structure stiff.
<b>Impermeable</b>	Cannot be penetrated.		
<b>Incising</b>	The operation of puncturing the lateral surfaces of wood as an aid in securing deeper and more uniform penetration of preservative.		



<b>Limnoria</b>	A type of crustacean borer.	<b>MSDS</b>	Material safety data sheets; information sheets provided by chemical manufacturers.
<b>Longitudinal tracheid</b>	Long thin cells that conduct sap and nutrients through out the tree.	<b>Natural durability</b>	Refers to wood's resistance to biological degradation due to the presence of extractives.
<b>Lowry process</b>	An empty cell process patented by C. B. Lowry in 1906 that omits an initial vacuum and begins filling the cylinder at atmospheric pressure.	<b>Nominal size</b>	Marketing size of lumber products, not actual size; means "in name only."
<b>Lumen</b>	The central opening in the cell.	<b>Oven dry (OD) basis</b>	A way of expressing moisture content for solid wood products, based on the oven-dry weight of wood. In contrast, the moisture content of pulp products is expressed on the basis of wood's green weight.
<b>Lyctid</b>	Powderpost beetle of the family Lyctus.	<b>PCF</b>	Pounds per cubic foot, a measure of preservative retention.
<b>Martesia</b>	A species of pholads resembling clams.	<b>PCP</b>	Penta or pentachlorophenol; a white crystalline solid $C_6Cl_5OH$ ; one of the major wood preservatives used in the US.
<b>Microfibrils</b>	Rope-like bundles of cellulose molecules that comprise the cell wall structure.	<b>Peeler</b>	Power-driven machine used to remove bark from poles and other round wood products. In the case of poles, often referred to as a pole shaving machine.
<b>Middle lamella</b>	The high lignen layer between adjacent cells that binds the cells together.	<b>Penetrant</b>	A liquid used as a carrier for a soluble wood preservative.
<b>Millwork</b>	Interior and exterior trim for buildings such as moldings, doors, windows, stairs, etc.	<b>Penetration</b>	The depth to which preservative enters the wood.
<b>Modified full cell process</b>	An adaptation of the Bethell process for use with waterborne preservatives.	<b>Penta</b>	See PCP.
<b>Moisture content (MC)</b>	As related to wood, the weight of water contained in wood, usually expressed as a percentage of the oven-dry weight of wood.	<b>Pentachlorophenol</b>	See PCP.
<b>Moisture meter</b>	An electrical instrument used to indicate the moisture content of wood.	<b>Phloem</b>	The inner bark of a tree, that is, the area between the cambium and the bark.
<b>Mold fungi</b>	Fungi that cause powdery surface growths on wood.		
<b>Molluscan borer</b>	A category of marine borers distantly related to clams: includes the shipworms and pholads.		



<b>Pholads</b>	One of the genera of molluscan borers.	<b>PSIG</b>	Pounds per square inch gage. Pressure measured with respect to the atmosphere.
<b>Phosphates</b>	A chemical used as a fire retardant treatment (FRT).	<b>PWF</b>	Permanent wood foundation, same as AWWF.
<b>Photosynthesis</b>	The process taking place in green leaves that manufactures food (glucose) for the plant and releases oxygen to the atmosphere.	<b>Radial shrinkage</b>	Change in the dimension of lumber at right angles to annual rings.
<b>Pile, piling</b>	A timber, usually round, that is embedded wholly or partly in the surface or underwater soil as a support for a superstructure such as a bridge, building, trestle, wharf, etc.	<b>Rays (ray cells)</b>	Cells that transport liquids horizontally across annual rings.
<b>Pith</b>	The center area of the transverse surface of a tree.	<b>Refractory</b>	Very difficult or resistant; in reference to treating, a refractory species is one that is difficult to penetrate with preservatives. In reference to drying, a refractory species is one that is more difficult to dry or more prone to certain defects.
<b>Pits</b>	Small openings in the cell walls of adjacent cells, which permit the flow of liquids between cells.	<b>Refusal treatment</b>	Treatment of wood under specified conditions until the quantity of preservatives absorbed in a given time is not more than a prescribed percentage of the amount already injected. Treatment to refusal does not, however, constitute an acceptable alternative to the minimum penetration and/or retention requirements specified under results of treatment except as specifically listed.
<b>Polymer</b>	A complex molecule made up of many smaller molecules.	<b>Reproductive</b>	Refers to the sexual adult in an ant or termite colony.
<b>Powderpost beetle</b>	A type of wood-boring insect that lives in and ingests dry wood.	<b>Retention by gauge or weight</b>	The amount of preservative, in pounds per cubic foot of the total charge remaining in the wood immediately after completion of the treating operation. Same as net absorption.
<b>Preservative, oilborne</b>	Preservatives dissolved in oil-type carriers or solvents; includes creosote, creosote-coal tar, penta, copper naphthenate, etc.		
<b>Preservative, waterborne</b>	Preservatives dissolved in water, such as CCA, ACA, etc.		
<b>PSI</b>	Pounds per square inch, a measure of pressure.		
<b>PSIA</b>	Pounds per square inch absolute. Pressure measured with respect to zero pressure.		



<b>Retention by assay</b>	The determination of preservative retention in a specified zone of treated wood by extraction or analysis of specified samples such as (a) increment borer cores or (b) chips obtained with a wood bit. The principle applies to freshly treated and to old treated material and to larger samples if necessary.	<b>Sodium pentachlorophenate</b>	A water soluble form of pentachlorophenol, at one time widely used as a sapstain control chemical.
<b>Retort</b>	Same as treating cylinder.	<b>Soft rot</b>	Deterioration of wood components, often without visual distortion or apparent damage to the wood, by certain molds and other fungi outside the common wood-destroying group. The affected wood is likely to be extremely brash and breaks without splinters.
<b>Rot</b>	Same as decay.	<b>Softwood</b>	The wood produced by one of the botanical group of trees that, in most cases, have needlelike leaves; the conifers. The term has no relevance to the actual hardness of the wood.
<b>Roundheaded borer</b>	A type of longhorn beetle whose larvae damage seasoned pine timbers.	<b>Soldier</b>	The termite colony member that protects the colony.
<b>RPAR</b>	Rebuttable presumption against registration; document issued by EPA.	<b>Solvent</b>	A liquid that dissolves and carries the preservatives into the wood.
<b>Rueping process</b>	An empty cell process patented by Max Rueping in 1902. This process admits the preservative after an initial pressure period has partially compressed air in the wood cells, thus permitting good penetration without overloading the cells.	<b>Species</b>	A variety of plant or animal.
<b>Sapstain fungi</b>	Fungi that live on the starch in sapwood cells; discoloring the wood not decaying it.	<b>Specific gravity</b>	As applied to wood, the ratio of the oven dry weight of a sample to the weight of a volume of water equal to the volume of the sample at specified moisture content (green, air dry or oven dry).
<b>Sapwood</b>	The outer light-colored wood of the tree stem which is physiologically active while the tree is growing.	<b>Split</b>	A lengthwise separation of the wood extending completely through the piece from one surface to another.
<b>Shake</b>	A separation along the grain of the wood usually occurring between the annual rings.	<b>Springwood</b>	Same as earlywood.
		<b>Standard building code</b>	One of three model building codes used in the U.S; written by the Southern Building Code Congress International, Inc.(SBCCI).



<b>Standards, treating</b>	Rules that detail how wood should be treated with preservative.	<b>Thermoplastic</b>	Refers to substances, such as lignin, that become pliable at high temperatures and stiff at colder temperatures.
<b>Steam conditioning</b>	A preconditioning process used to dry green wood in the treating cylinder by injecting pressurized steam at about 240° F for a limited time.	<b>Threshold</b>	The minimum amount of preservative that is effective in preventing significant decay, under the conditions of the test, by a particular fungus. This amount of preservative in pounds per cubic foot (pcf), or Kilograms per cubic meter (kg/m <sup>3</sup> ) of wood, is referred to as the "threshold retention."
<b>Steeping</b>	A cold soaking process using preservatives dissolved in a water solution.	<b>Timbers</b>	Any square or rectangular wood products with a minimum thickness of 4".
<b>Stickers</b>	Spacers used between pieces of lumber being dried.	<b>Uniform building code</b>	One of three model building codes used in the US; written by the International Conference of Building Officials (ICBO).
<b>Summerwood</b>	Same as latewood.	<b>Vapor pressure</b>	The property that causes a chemical to evaporate. The lower the vapor pressure, the more easily it will evaporate.
<b>Sump</b>	A catch basin used to collect drainage from the treating operation.	<b>Vessels</b>	Large hollow cells found in hardwood trees, that transport water.
<b>Tangential shrinkage</b>	Change in the dimension of lumber parallel to annual rings.	<b>Viscosity</b>	A property of liquids that determines whether they flow readily. Viscosity usually increases when temperature decreases.
<b>Tar oil</b>	A tar obtained by the high-temperature thermal decomposition of a petroleum oil.	<b>Volatile</b>	Evaporates at ordinary temperatures when exposed to air.
<b>TBTO</b>	Bis-(tri-n-butyltin) oxide. A colorless preservative dissolved in light petroleum solvents, used in paints and stains and limited to aboveground uses.	<b>Waxes</b>	Additives to preservative solutions designed to make wood more water-repellent.
<b>Teredo</b>	A species of molluscan borer, commonly called shipworms.		
<b>Termite</b>	A type of insect that lives in colonies in the ground, but feeds on wood and can be very destructive.		
<b>Thermal process</b>	Same as hot-and-cold bath process.		



---

<b>Weathering</b>	The mechanical or chemical disintegration and discoloration of the surface of wood caused by exposure to light, the action of dust and sand carried by winds, and the alternate shrinking and swelling of the surface fibers caused by continual changes in moisture content and temperature. Weathering does not include decay.
<b>White rot</b>	Fungi that break down lignin and cellulose, bleaching the affected wood.
<b>Wood preservation</b>	The art of protecting timber against the action of destructive agents. Usually refers to the treatment of wood with chemical substances (preservatives) which reduce its susceptibility to deterioration by fungi, insects, or marine borers.
<b>Workers</b>	The caste members in ant or termite colonies that gather food.
<b>Xylem</b>	The woody part of a tree; includes both heartwood and sapwood.
<b>Zinc naphthenate</b>	A colorless oilborne preservative used for above ground applications.



## References

### Selected publications on wood technology and preservation.

*Wood Handbook: Wood as an Engineering Material*, Agriculture Handbook No. 72. Revised 1987. Prepared by the Forest Products Laboratory, USDA Forest Service. Available from the Superintendent of Documents, U.S. Government Printing Office, Washington, DC 20402. 466 pages.

*Textbook of Wood Technology*. 1980. A.J. Panshin, and C. deZeeuw. McGraw-Hill Book Company, 1221 Ave. of Americas, New York, NY 10020. 705 pages.

*Understanding Wood*. 1980. R. Bruce Hoadley. The Taunton Press, Inc., P.O. Box 5506, Newtown, CT 06470. 256 pages.

*Identifying Wood*. 1990. R. Bruce Hoadley. The Taunton Press, Inc., P.O. Box 5506, Newtown, CT 06470. 223 pages.

*Forest Products and Wood Science: An Introduction*. 1989. John Haygreen and Jim Bowyer. Iowa State University Press, 21215 State Ave., Ames, IA 50010. 500 pages.

*Wood Deterioration and Its Prevention by Preservative Treatment*. Vol. 1—Degradation and Protection of Wood, 380. pages Vol. 2—Preservatives and Preservative Systems, 402 pages. 1973. Darrel D. Nicholas, editor; assisted by Wesley E. Loos. Syracuse University Press, Syracuse, NY 13210.

*Biodegradation and Preservation of Wood: List of Publications*. 1989. Available from USDA Forest Service, Forest Products Laboratory, One Gifford Pinchot Dr., Madison, WI 53705-2398. 16 pages.

*Selecting Preservative Treated Wood (with Special Emphasis on Landscape Timbers)*. Thomas R. Hoffman, Lewis T. Hendricks and Kevin L. Powell. 1992. Item No. FO-0897. Available from

the Minnesota Extension Service, Distribution Center, 20 Coffey Hall, University of Minnesota, 1420 Eckles Ave., St. Paul, MN 55108. 8 pages.

*Wood Preservation and Wood Products Treatment Training Manual*. 1989. Item No. EM 8403, Oregon State University Extension Service, Forest Research Lab, College of Forestry, OSU, Corvallis, OR 97331. 12 pages.

*Safe Use of Preservatives and Preservative Treated Wood at Home and on the Farm: A Guide for the Pacific Northwest*. 1988. J. J. Morrell, R. D. Graham and D.J. Miller. Special Publication 15. Forest Research Lab, College of Forestry, OSU, Corvallis, OR 97331. 21 pages.

*Selection, Production, Procurement and Use of Preservative-Treated Wood, Supplementing Federal Specification*. TT-W-571. 1977. L.R. Gjovik and R. H. Baechler. USDA Forest Service, Gen. Tech. Report FPL-15. Available from Forest Products Lab, One Gifford Pinchot Dr., Madison, WI 53705-2398. 37 pages.

*The Biologic and Economic Assessment of Pentachlorophenol, Inorganic Arsenicals, Creosote*, Vol. 1: Wood Preservatives. 1980. USDA Cooperative Impact Assessment Report. Technical Bulletin 1658. 1435 pages.

*Ground Line Inspection and Preservative Retreatment of Standing Wood Utility Poles*. 1991. James Pastoret. North Central Regional Extension Publication No. NCR 364. Available from Extension Publications, 115 South 5th St., University of Missouri-Columbia, Columbia, MO 56211; 16 pages.

*Preservative-Treatment of Lumber and Wood Products: Pesticide Applicator Training Manual*. Category 7. 1987. Cooperative Extension, New York State College of Agriculture and Life Sciences, Cornell University, Ithaca, NY; 14853 88 pages.



---

# Associations

## **American Lumber Standards Committee**

P.O. Box 210  
Germantown, MD 20875-0210  
301-972-1700

## **American Wood Preservers Association**

P.O. Box 286  
Woodstock, MD 21163-0286  
410-465-3169

## **American Wood Preservers Institute**

1945 Old Gallows Road, Ste. 550  
Vienna, VA 22180  
703-893-4005

## **National Rural Electric Cooperative Association**

Attn: Jim Carter  
106 Kensington Drive, #409  
Spartanburg, SC 29301  
803-574-8714

## **Railway Tie Association, Inc.**

P.O. Box Drawer 1039  
Gulf Shores, AL 36542  
205-968-5927

## **Southern Forest Products Association**

P.O. Box 641700  
Kenner, LA 70064-1700  
504-443-4464

## **Southern Pressure Treaters Association**

P.O. Box 2389  
Gulf Shores, AL 36547  
205-968-5726

## **Western Wood Preservers Institute**

601 Main St., Ste 401  
Vancouver, WA 98660  
206-693-9958



---

## MINNESOTA EXTENSION SERVICE

UNIVERSITY OF MINNESOTA  
COLLEGE OF  
NATURAL RESOURCES

### **To order additional copies fax or write:**

Minnesota Extension Service  
MES Distribution Center  
20 Coffey Hall  
1420 Eckles Avenue  
St. Paul, MN 55108-6069  
FAX Number (612) 625-6281

For price and availability call (800) 876-8636 or, in the Twin Cities, (612) 625-8173

Funding provided by: Minnesota Extension Service [the Renewable Resources Extension Act (RREA) program of the Minnesota Extension Service and the U.S. Department of Agriculture—Cooperative States Research, Education and Extension Services (CSREES)].

In accordance with the Americans with Disabilities Act, this material is available in alternative formats upon request. Please contact your Minnesota county extension office or, outside of Minnesota, contact the Distribution Center at (800) 876-8636.

The University, including the Minnesota Extension Service, is committed to the policy that all persons shall have equal access to its programs, facilities, and employment without regard to race, color, creed, religion, national origin, sex, age, marital status, disability, public assistance status, veteran status, or sexual orientation.

The information given in this publication is for educational purposes only. Reference to commercial products or trade names is made with the understanding that no discrimination is intended and no endorsement by the Minnesota Extension service is implied.



Printed on recycled paper using a minimum of 10% post consumer waste.