



Solar Water Heating Options in Florida¹

John Harrison and Tom Tiedemann²

INTRODUCTION

This document is intended to acquaint Florida's general public with typical methods of heating household water by means of the sun. The types of solar systems discussed are pumped (both direct and indirect), thermosiphon and integral collector storage. The systems illustrated in Figures 1-6 can be seen at the Florida Solar Energy Center's Solar Training and Education Project facility.

DIRECT PUMPED SYSTEM

This is the type of system most common in Florida. As illustrated in Figure 1, it has one or more solar energy collectors installed on the roof and a storage tank somewhere below, usually in the garage or a utility room. A pump circulates the water from the tank up to the collector and back again. This is called a direct (or open loop) system because the sun's heat is transferred directly to the potable water circulating through the collector tubing and storage tank; no antifreeze solution or heat exchanger is involved.

This system has a differential controller, which senses temperature differences between water leaving the solar collector and the coldest water in the storage tank. When the water in the collector is about 20°F warmer

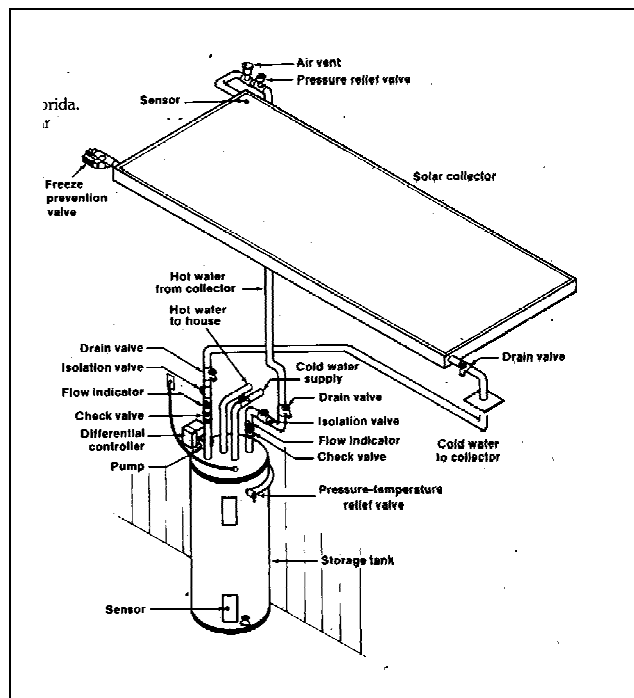

Figure 1. Typical direct pumped system.

than the water in the tank, the pump is turned on by the controller. When the temperature difference drops to about 5°F, the pump is turned off. In this way, the water always gains heat from the collector when the

1. This document is FSEC Publication EN-9, provided for the Energy Resource CD-ROM by the Florida Energy Extension Service, Florida Cooperative Extension Service, Institute of Food and Agricultural Sciences, University of Florida. Publication date: May 1994. First published: February 1985.
2. John Harrison, Assistant in Institutional Research and Tom Tiedemann, Research Associate, Florida Solar Energy Center, State University System of Florida, 300 State Road 401, Cape Canaveral, Florida 32920. © Copyright 1985, Florida Solar Energy Center.

The Florida Energy Extension Service receives funding from the Energy Office, Department of Community Affairs, and is operated by the University of Florida's Institute of Food and Agricultural Sciences through the Cooperative Extension Service. The information contained herein is the product of the Florida Energy Extension Service and does not necessarily reflect the view of the Florida Energy office.

The Institute of Food and Agricultural Sciences is an equal opportunity/affirmative action employer authorized to provide research, educational information and other services only to individuals and institutions that function without regard to race, color, sex, age, handicap, or national origin. For information on obtaining other extension publications, contact your county Cooperative Extension Service office.
Florida Cooperative Extension Service / Institute of Food and Agricultural Sciences / University of Florida / Christine Taylor Stephens, Dean

pump operates. Flow indicators mounted in the pipes indicate when the pump is operating.

A valve installed near the collector provides freeze protection. Whenever temperatures approach freezing, the valve opens to let warm water flow through the collector. The collector also can be manually drained by closing the isolation valves (located above the storage tank) and opening the drain valves.

Automatic recirculation is another means of freeze protection for this type of system. When the water in the collector reaches a temperature near freezing, the controller turns the pump on for a few minutes to warm the collector with water from the tank.

The system shown in Figure 2 differs from other direct pumped systems in that the energy to power the pump is provided by a photovoltaic panel. The photovoltaic panel converts sunlight into electricity, which drives the direct current (dc) pump. In this way, water flows through the collector only when the sun is shining.

The dc pump and photovoltaic panel are suitably matched to ensure proper performance. The pump starts when there is sufficient solar radiation available to heat the thermal collector panel. It shuts off later in the day when the available solar energy diminishes. As in the previous system, a thermally operated valve provides freeze protection.

Common appliance timers also may control system operation. The timer is set to operate during a period of the day when solar insolation is available to heat the potable water. In order to avoid loss of energy from the tank during overcast days, the collector feed and return lines are both connected at the bottom of the storage tank. During normal operation, natural stratification allows the warmer water to rise to the top part of the tank.

INDIRECT PUMPED SYSTEM

This system design is common in northern climates, where freezing weather occurs more frequently. An antifreeze solution circulates through the collector, and a heat exchanger transfers the heat from the antifreeze solution to the tank water. When toxic heat-exchange fluids are used, a double-walled exchanger is required. Generally, if the heat exchanger is installed in the storage tank, it should be in the lower half of the tank where the cooler water is.

The system illustrated in Figure 3 is an example of this system type. Here a heat transfer solution is pumped through the collector in a closed loop. The loop includes the collector, connecting piping, the pump, an expansion tank and a heat exchanger. A heat exchanger coil in the lower half of the storage tank transfers heat from the heat transfer solution to the potable water in the solar storage tank. In this design the large heat exchanger wraps around the tank, which keeps it from contact with potable water.

The brain of this system is a differential controller. In conjunction with collector and tank temperature sensors, the controller determines when the pump should be activated to pump the heat transfer fluid through the collector.

A fail-safe method of ensuring that collectors and collector pipe lines never freeze is to remove all water from the collectors and piping when the system is not collecting heat. This is a major feature of the drain-back system illustrated in Figure 4. Freeze protection is provided when the system is in the drain mode. Water in the collectors and exposed piping drains into the insulated reservoir tank each time the pump shuts off. The slight tilt of the collectors allows complete drainage. A sight glass attached to the reservoir tank shows when the reservoir tank is full and the collectors have been drained.

When the sun shines again, the pump is activated by a differential controller. Water is pumped from the

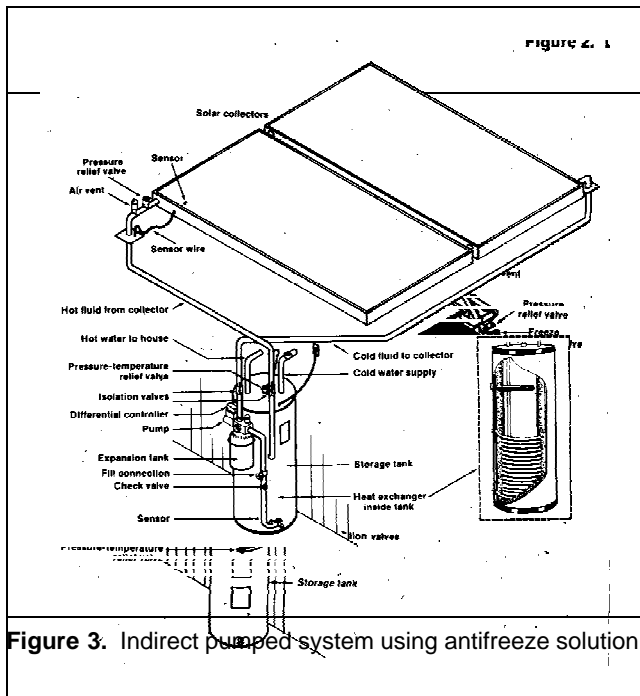

Figure 3. Indirect pumped system using antifreeze solution.

Figure 2. Direct system with photovoltaic-powered pump.

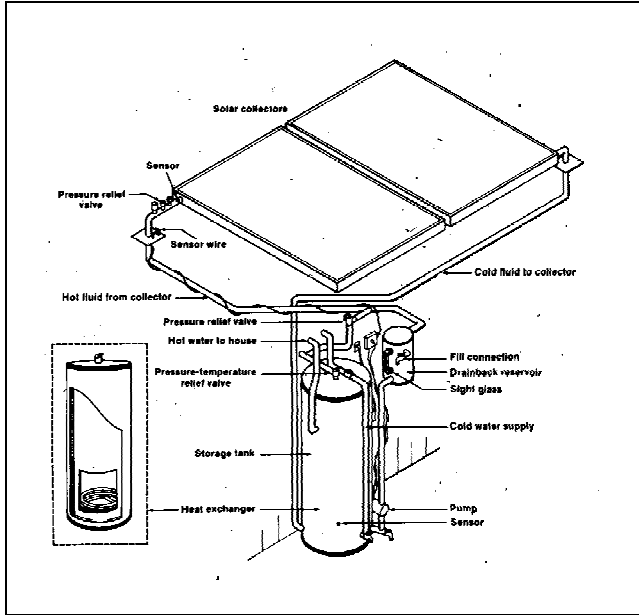

Figure 4. Indirect system using distilled water.

reservoir to the collectors, allowing heat to be collected. The water stored in the reservoir tank circulates in a closed loop through the collectors and a heat exchanger coil in the bottom of the solar tank. The heat exchanger transfers heat from the collector loop fluid to the potable water in the solar tank.

The fluid used in this system is a mixture of distilled water and antifreeze similar to that used in automobiles. This type of fluid freezes only at *extremely* low temperatures so the system is protected from damage caused by severe cold.

THERMOSIPHON SYSTEM

Thermosiphon systems were widely used in the early days of solar water heating in Florida. They are automatic, simple and reliable. A typical system is illustrated in Figure 5.

As the sun shines on the collector, the water inside is heated. It expands slightly and becomes lighter than the cold water in the tank. Gravity then pulls heavier, cold water down from the tank and into the collector inlet. The cold water pushes the heated water through the collector outlet and into the top of the tank. This continuous heating and flowing action provides a tank full of hot water at the end of the day.

A thermosiphon system requires neither pump nor controller. Cold water from the city water line flows directly to the tank on the roof. Solar heated water

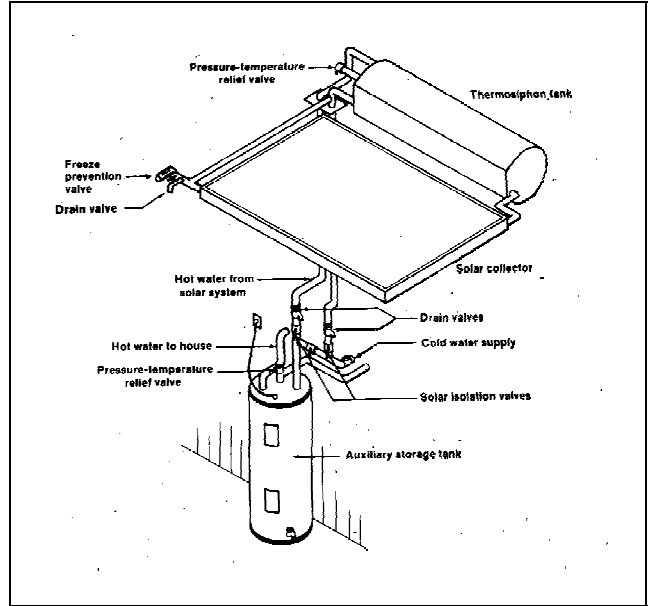

Figure 5. Thermosiphon system.

flows from the rooftop tank to the auxiliary tank installed at ground level whenever water is used within the residence.

This system features a thermally operated valve that protects the collector from freezing. It also includes isolation valves, which allow the solar system to be bypassed completely.

INTEGRAL COLLECTOR STORAGE (ICS) SYSTEM

This system predates the thermosiphon system. Although in its simplest form it cannot produce as much heat as more conventional systems, it can provide reasonably hot water, or it can serve as a cost-effective preheater for a conventional electric or gas heater. Figure 6 is an illustration of this type of system.

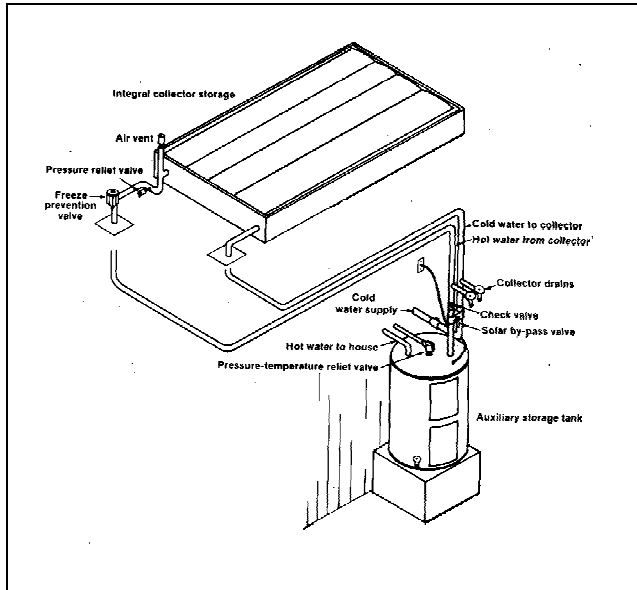

Figure 6. Integral collector storage system.

In this solar system, the hot water storage system is part of the collector. Cold water flows progressively through four stainless steel tanks where it is heated by the sun. Hot water is drawn from the hottest tank at the top, and replacement water is contained in the lower tanks. Pumps and controllers are not required. On demand, hot water from the collector flows to a standard hot water auxiliary tank within the structure. A solar bypass valve can isolate the solar collector, so the auxiliary tank can be used as a standard water heater.

A freeze protection valve is installed in the plumbing line near the collector. Whenever temperatures near freezing, this valve opens to allow relatively warm water to flow through the collector to prevent freezing. The collector also may be drained manually with collector drain valves.

FOR MORE INFORMATION

FSEC has other publications on solar heating of household water and swimming pools. Topics include economics, installation, tax incentives and sizing. To obtain these publications contact FSEC's Public Information Office.