

# WMRC Technology Update

## Acid Recycling Technology

### The High Cost of Disposal

Wastes from plating and other wet processing operations are a permanent liability for the generator. With the Resources Conservation and Recovery Act (RCRA) and other legislation, the legal, financial and moral obligations imposed on waste generators have become a major area of concern.

Recovering acids from process waste avoids the costly problems of treatment, disposal, reporting and liability. Cleaner process baths improve manufacturing quality and maximize production capacity.

### Gerlin, Inc. Case Study

Gerlin, Inc., a manufacturer of stainless steel fittings and flanges in Carol Stream, IL, maintains a 1,500 gallon nitric acid and ammonium bifluoride pickling bath. The bath becomes depleted in 6-8 weeks and is recharged seven times a year. Gerlin's waste disposal costs \$18,000 annually and fresh chemical make-up costs \$13,000 per year.

WMRC engineers developed a successful pilot project using diffusion dialysis to assist Gerlin. The diffusion dialysis unit recovered 86% of the nitric acid and 30% of the ammonium bifluoride. The unit rejected 88% of the iron, 89% of the chromium, and 80% of the nickel.

Implementation of diffusion dialysis will increase Gerlin's productivity as a result of reduced pickling time and reduced rework. These factors were the company's foremost decision points for implementing the technology. Additionally, implementing dialysis will reduce pickling bath discharges to twice per year, providing a savings in disposal costs of more than \$10,000 per year.

### Pickling and Plating Solution Recovery

Are you disposing of thousands of gallons of acidic waste yearly? Do you consider the cost of waste disposal as an operation expense? Would you like to reuse your acidic process solution indefinitely?

If you answered yes to any of these questions, then acid recovery technology through diffusion dialysis may be the answer you need.

Diffusion dialysis is a membrane separation technology designed for the metal finishing industry to recover nitric, hydrochloric, hydrofluoric, fluoboric, or sulfuric acids from depleted process baths (Figure 1). The acid is returned to the process for continued use and a dilute stream containing the bath contaminants and a small amount of acid are rejected.

Diffusion dialysis acid recovery can reduce the quantity of process solution being disposed and save costly chemicals that can be reused.

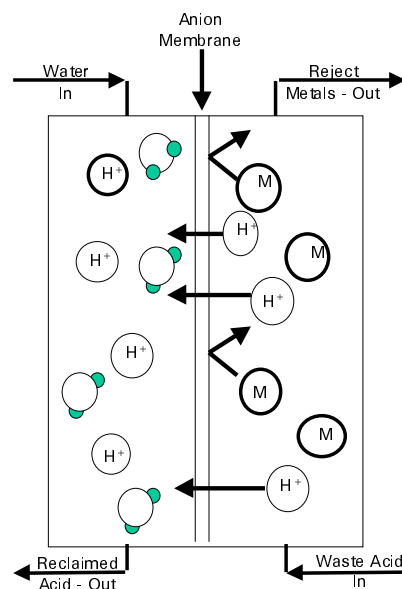

Figure 1: Diffusion Dialysis Cell Pair

### Acid Recycling System Operation

The used acid is metered through the system in contact with one side of an anionic ion exchange membrane (Figure 1). Water is metered in a counter-current fashion on the recovery side of the membrane. The majority of the acid migrates through the membrane into the water, rejecting contaminants such as heavy metals. The purified acid and water is directed back to the process tank, while the contaminant-laden spent acid stream goes to metal recovery or waste treatment for further processing (Figure 2). Fresh acid in proportion to the unrecovered amount is added to the bath to maintain the concentration within the correct operating parameters.

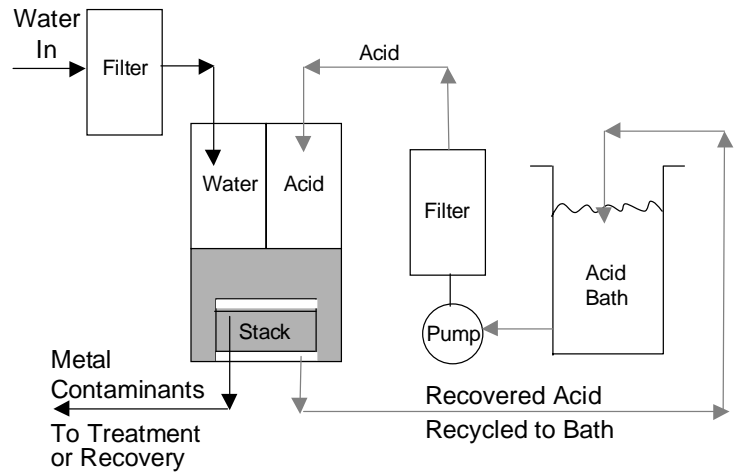

Figure 2: Acid Recycling Flow Diagram

For More Information Contact:

Ken Barnes  
Process Improvement Program  
Waste Management and Research Center  
1 East Hazelwood Drive  
Champaign, IL 61820  
217-244-9940