



*Report of Survey Conducted at*

**WATERVLIET ARSENAL**  
WATERVLIET, NEW YORK

*JULY 1992*

# ***BEST MANUFACTURING PRACTICES***



*Center of Excellence for Best Manufacturing Practices*



# CONTENTS

---

## 1. EXECUTIVE SUMMARY

1.1	BACKGROUND.....	1
1.2	BEST PRACTICES.....	1
1.3	INFORMATION.....	2

---

## 2. INTRODUCTION

2.1	SCOPE .....	3
2.2	SURVEY PROCESS.....	3
2.3	NAVY CENTERS OF EXCELLENCE.....	3
2.4	COMPANY OVERVIEW .....	3
2.5	ACKNOWLEDGMENTS.....	3
2.6	COMPANY POINT OF CONTACT .....	3

---

## 3. BEST PRACTICES

### 3.1 DESIGN

#### DESIGN POLICY

Advanced Tank Cannon Technology Programs .....	7
--	---

#### DESIGN PROCESS

Producibility Enhancements Through CAD Tools .....	8
Composites Laboratory .....	8

### 3.2 TEST

#### INTEGRATED TEST

Breech Fatigue Simulation .....	8
Proof Firing Test Simulation .....	9

### 3.3 PRODUCTION

#### MANUFACTURING PLAN

Computer-Aided Process Planning .....	9
---------------------------------------	---

#### PIECE PART CONTROL

Rotary Forge Collection System.....	10
-------------------------------------	----

#### DEFECT CONTROL

Predictive Maintenance Vibration Analysis .....	11
---	----

# CONTENTS (Continued)

---

	<b>DEFECT CONTROL (CONTINUED)</b>	
	Spindle Live Center Test System .....	11
	Gun Tube Inspection .....	12
	Gun Tube Inspection Station .....	12
	<b>COMPUTER-AIDED MANUFACTURING</b>	
	Chrome Plate Automated Control and Monitoring System .....	12
	Tensile and Charpy Manufacturing Cell .....	13
	Rotary Forging Process and Associated Heat Treatment .....	13
	DNC System .....	14
<b>3.4</b>	<b>FACILITIES</b>	
	<b>MODERNIZATION</b>	
	Acquisition Monitoring System for Renovation of Armament Manufacturing Project .....	15
	<b>PRODUCTIVITY CENTER</b>	
	Manufacturing Support Computer Center .....	15
	Database Managers Reference Guide .....	16
<b>3.5</b>	<b>LOGISTICS</b>	
	<b>TRAINING MATERIALS AND EQUIPMENT</b>	
	Apprentice Training Program .....	16
<b>3.6</b>	<b>MANAGEMENT</b>	
	<b>MANUFACTURING STRATEGY</b>	
	Total Quality Management Program .....	17
	Enterprise Level Strategic Plan .....	17
	Advanced Contracting Methodologies .....	18
	Improved Maintenance Performance and Control Thrust .....	18
	Rapid Parts Prototyping and Production Using Flexible Computer-Integrated Manufacturing .....	18
	Customer Program Development and Service Office .....	19
	<b>PERSONNEL REQUIREMENTS</b>	
	Self Assessment Program .....	19
	<b>DATA REQUIREMENTS</b>	
	Process Control Discipline: Guidelines and Improvements .....	19

# CONTENTS (CONTINUED)

---

## 4. INFORMATION

### 4.1 DESIGN

#### DESIGN PROCESS

Engineering Support in Production Mission .....21

#### DESIGN ANALYSIS

XM35 and XM291 Programs and  
Development of XM91 Autoloader .....21

#### PARTS AND MATERIAL SELECTION

Gun Barrel Plating Studies .....21

#### COMPUTER-AIDED DESIGN

Concurrent Engineering: Computer-Aided  
Logistics Support; PDES .....22

### 4.2 PRODUCTION

#### MANUFACTURING PLAN

Combined Gun Tube Straightness Technology .....22

Quick Response Manufacturing .....22

#### PIECE PART CONTROL

Development of Shop Floor Control System .....23

#### TOOL PLANNING

Development and Implementation of a Tool/  
Gage Management System.....23

Computerized Maintenance Management System .....24

#### COMPUTER-AIDED MANUFACTURING

Automated Statistical Process Control .....24

Information Systems Modeling .....24

Hazardous Material Accountability .....24

#### SPECIAL TEST EQUIPMENT

Use of Neural Network Technology for  
Non-destructive Testing .....25

Metrology and Inspection Division .....25

Gage Design .....25

### 4.3 FACILITIES

#### MODERNIZATION

Project REARM .....25

Flexible Manufacturing Cell .....26

# CONTENTS (Continued)

---

## **FACTORY IMPROVEMENTS**

Advanced CIM Project .....26

### **4.3 MANAGEMENT**

#### **MANUFACTURING STRATEGY**

Program Management Tools .....27

Minimization of Waste Streams .....27

#### **DATA REQUIREMENTS**

Customer Feedback .....27

---

## **5. PROBLEM AREAS**

### **5.1 DESIGN**

#### **DESIGN POLICY**

Non-developmental Item Procurement.....29

### **5.2 MANAGEMENT**

#### **DATA REQUIREMENTS**

DoD Accounting Requirements .....29

---

**APPENDIX A - TABLE OF ACRONYMS** .....A-1

**APPENDIX B - BMP SURVEY TEAM** .....B-1

**APPENDIX C - NAVY CENTERS OF EXCELLENCE** .....C-1

**APPENDIX D - PREVIOUSLY COMPLETED SURVEYS** .....D-1

---

# FIGURES

---

3-1	Original Flow of Rotary Forge Data .....	10
3-2	Present Flow of Rotary Forge Data .....	11
3-3	DNC System Architecture .....	14
3-4	AOD Hardware Configuration .....	15
3-5	AOD Computer Center Cluster Configuration .....	16
4-1	Customer Feedback System .....	28

---

# SECTION 1

## EXECUTIVE SUMMARY

---

### 1.1 BACKGROUND

The Navy's Best Manufacturing Practices (BMP) team conducted a survey at the Army's Watervliet Arsenal (WVA), in Watervliet, New York the week of 13 - 17 July 1992. This survey included the Army's Benet Laboratories that are collocated with the Arsenal. The purpose of the WVA survey was to review and document its best practices and investigate any potential industry-wide problems. The BMP program will use this documentation as an initial step in a voluntary technology sharing process among the industry and government.

### 1.2 BEST PRACTICES

The best practices documented at WVA are detailed in this report. These topics include:

Item	Page
<b>Advanced Tank Cannon Technology Programs</b>	7
The Advanced Tank Cannon Technology Program generates and coordinates high risk research and development projects involving technology related to existing tank cannon.	
<b>Producibility Enhancements through CAD Tools</b>	8
Benet Laboratories has assembled a complete CAD analysis capability that allows exploration of new design concepts.	
<b>Composites Laboratory</b>	8
Benet Laboratories has developed a composites laboratory to research composite technology and development of the manufacturing techniques to implement composite structures in production.	
<b>Breech Fatigue Simulation</b>	8
This simulation program for breech mechanisms allows rapid and cost effective testing of hardware configurations to establish the fatigue life characteristics for service safety.	
<b>Proof Firing Test Simulation</b>	9
The proof firing test simulation program fully tests a product for fit, form, and function under simulated firing condition stresses to reduce live firing test requirements.	

Item	Page
<b>Computer-Aided Process Planning</b>	9
The WVA Production Planning and Control Division is prepared to address future manufacturing requirements using the capability to quickly produce accurate production routings through the CAPP system.	
<b>Rotary Forge Data Collection System</b>	10
A new Rotary Forge Data Collection system with a simplified flow process and 407 fields was implemented in 1988 that has updated the processing of material data.	
<b>Predictive Maintenance Vibration Analysis</b>	11
WVA initiated a predictive maintenance program based on vibration analysis to help avoid critical equipment failures.	
<b>Spindle Live Center Test System</b>	11
To address the issue of substandard surface finish of gun tubes, WVA established a program to gather and assimilate data determining that excessive spindle vibrations cause unacceptable surface finishes in gun tubes.	
<b>Gun Tube Inspection</b>	12
The current method of determining the gun tube straightness at WVA consists of a laser and photo position sensor or target that travels through the bore taking measurements relative to the centerline.	
<b>Gun Tube Inspection Station</b>	12
WVA designed and built an automated Gun Tube Inspection Station using the central computer controller and commercial electronic gaging systems to measure straightness, concentricity, bore diameter, and chrome plate thickness.	
<b>Chrome Plate Automated Control and Monitoring System</b>	12
The problem of chrome loss during proof firing of the 120mm tubes prompted the implementation of a Watervliet Improvement Program. The result was a significant decrease in the instance of chrome loss during proof-firing and the development of a very robust chrome plating process.	

<b>Item</b>	<b>Page</b>	<b>Item</b>	<b>Page</b>
<b>Tensile and Charpy Manufacturing Cell</b> WVA has designed and implemented a manufacturing cell to produce ASTM compliant tensile and charpy test specimens that are required for each gun tube.	13	sive action in developing a continually updated, living plan that is guiding today's changes and future directions.	
<b>Rotary Forging Process and Associated Heat Treatment</b> Watervliet has implemented a rotary forge and heat treating system resulting in notable process time savings, improved forging straightness, minimized wall variation, and enhanced process control.	13	<b>Advanced Contracting Methodologies</b> The Procurement and Contracting Directorate develops systems to meet DoD logistics system needs and potential commercial markets for rapid prototyping, while initiating changes to save the Arsenal money and improve its performance.	18
<b>DNC System</b> As part of the original CIM strategy associated with REARM, WVA instituted a three-phase DNC system.	14	<b>Improved Maintenance Performance and Control Thrust</b> The Improved Maintenance Performance and Control Thrust Project was initiated to focus top level planning and bring maintenance initiatives into existence in a controlled, structured, and efficient manner.	18
<b>Acquisition Monitoring System for Renovation of Armament Manufacturing Project</b> A computer software system was developed to help track the procurement actions and associated scheduling during WVA's Renovation of Armament Manufacturing (REARM) modernization effort.	15	<b>Rapid Parts Prototyping and Production Using Flexible Computer-Integrated Manufacturing</b> WVA can provide a quick turnaround capability in the production of critically-needed parts as part of the program entitled Flexible Computer-Integrated Manufacturing.	18
<b>Manufacturing Support Computer Center</b> This Center provides administrative and support services needed to effect implementation and continuous improvement of installed CIM technologies.	15	<b>Customer Program Development and Service Office</b> To enhance customer service as well as plan and develop business strategies for the future, WVA has established a single customer service organization.	19
<b>Database Managers Reference Guide</b> WVA developed a MetCAPP Utilities Database Managers Reference Guide to facilitate consistent data input and interpretation of data during implementation of a Computer-Aided Process Planning system.	16	<b>Self Assessment Program</b> This program has proven to be a useful and powerful tool for identifying areas at WVA that require improvement and need formal executive focus.	19
<b>Apprentice Training Program</b> WVA has made an intensive, visionary commitment to development of highly qualified, journeyman-level talent.	16	<b>Process Control Discipline: Guideline and Improvements</b> A baseline assessment at WVA in manufacturing operations resulted in the implementation of a Process Control Program based on well-defined procedures and employee discipline.	19
<b>Total Quality Management Program</b> The TQM Program at the Arsenal consistently applies objective, analytical problem solving to all levels of management thought and action, from strategic planning to factory floor operations.	17		
<b>Enterprise Level Strategic Plan</b> WVA is adapting for survivability in response to recent global changes. After recently completing a large scale modernization of facilities and manufacturing capability, the Arsenal has taken aggressive	17		

### **1.3 INFORMATION**

The following information items are detailed in this report:

<b>Engineering Support in Production Mission</b> The Engineering Support in Production program at WVA, developed through Benet Laboratories, integrates three critical support functions that are basic to a successful manufacturing effort.	21
--	----

<b>Item</b>	<b>Page</b>	<b>Item</b>	<b>Page</b>
<b>XM35 and XM291 Programs and Development of XM91 Autoloader</b>	21	processes have been identified as automated SPC pilot program candidates.	
Benet Laboratories recently established goals for three programs it is developing – the XM35, XM291 and XM91 Autoloader.		<b>Information Systems Modeling</b>	24
<b>Gun Barrel Plating Studies</b>	21	WVA has extensive plans for an integrated manufacturing information system to enable it to efficiently share data among a wide variety of organizations within the enterprise.	
Benet Laboratories has several chromium coatings under research and development.		<b>Hazardous Material Accountability</b>	24
<b>Concurrent Engineering; Computer-Aided-Logistics Support; PDES</b>	22	To meet government and WVA requirements, a Hazardous Materials Management program was developed in conjunction with the selection of a Hazardous Waste Minimization program.	
These are new efforts for the Watervliet Arsenal. They comprise a coordinated effort by WVA to develop computer-based product data systems to facilitate information flow and close interaction among the Arsenal’s components.		<b>Use of Neural Network Technology for Non-destructive Testing</b>	25
<b>Combined Gun Tube Straightness Technology</b>	22	Benet Laboratories is using neural network technology on non-destructive testing techniques that previously had not yielded results through traditional analysis.	
Efforts are underway to improve manufacturing processes used in the production of the 120mm M256 gun tubes to reduce or eliminate straightening.		<b>Metrology and Inspection Division</b>	25
<b>Quick Response Manufacturing</b>	22	The Metrology and Inspection Division acquires, accepts, supplies, inventories, maintains, repairs and disposes of inspection equipment and manages the Arsenal inspection equipment calibration program and supply calibration service.	
During the Desert Storm operation, WVA participated as a member of a consortium to produce – in under one month – a bomb designed to destroy deeply buried reinforced concrete bunkers.		<b>Gage Design</b>	25
<b>Development of Shop Floor Control System</b>	23	The Quality and Instrumentation Engineering Branch at WVA develops final acceptance inspection, and test equipment and field gages in support of manufacturing production, field operations, and operations directorates.	
WVA learned valuable lessons in developing its shop floor control system and has submitted the information for the benefit of companies evaluating similar approaches.		<b>Project REARM</b>	25
<b>Development and Implementation of a Tool/Gage Management System</b>	23	WVA addressed the problem of aging equipment and facilities and its inability to secure funding for acquisition and necessary upgrades by implementing REARM, a program that has added 305 new and 41 rebuilt machine tools, and added 186,000 square feet of modern plant facilities.	
To solve problems in managing its tools and gages, WVA established a joint WVA/contractor team to develop and implement a Tool/Gage Management system.		<b>Flexible Manufacturing Cell</b>	26
<b>Computerized Maintenance Management System</b>	24	Flexible manufacturing and automation will provide WVA with the capability to meet large increases in demand or a sudden need to shift product mix without a decrease in production efficiency.	
Recognizing that equipment must be maintained in good working condition to safely produce a quality product on time, WVA implemented a computerized maintenance management system. When this new software is implemented, WVA’s maintenance department will be more prepared to pro-actively react to manufacturing needs.		<b>Advanced CIM Project</b>	26
<b>Automated Statistical Process Control</b>	24	The Advanced CIM program at WVA has grown to be a multimillion dollar project with significant impacts on manufacturing, product quality, and production capability and capacity.	
A specification development for the automated SPC project is underway and approximately 20-30			

---

<b>Item</b>	<b>Page</b>
<b>Program Management Tools</b>	27
To provide the required detailed status information to its customer and enable WVA to improve its competitive posture, the Information Management Directorate recently developed sales and costs reports for the 120mm Mortar Program.	
<b>Minimization of Waste Streams</b>	27
WVA initiated a program that addresses the disposal costs associated with several hazardous materials.	
<b>Customer Feedback</b>	27
WVA has a consolidated customer feedback program under development in support of the firing records that it maintains for Army cannon, howitzers, and mortars. The database will provide the information for customer inquiries, complaints, field failures/malfunctions, problems, comments, remaining life requests, and the proposed gun card questionnaire in a more timely manner than the current hard copy systems.	

## **1.4 PROBLEM AREAS**

<b>Item</b>	<b>Page</b>
The following problem areas are discussed in this report.	
<b>Non-Developmental Item Procurement</b>	29
Lessons learned from a non-developmental item procurement include that drawing conventions are dissimilar between U.S. and foreign companies; specifications for foreign parts are not readily available in the U.S., and the foreign source's philosophy of "fit at assembly" does not work.	
<b>DoD Accounting Requirements</b>	29
The long-term future of government manufacturing facilities like WVA may be determined by the cost, pricing, and accounting practices they are obliged to follow. As factories like WVA improve the precision and producibility of their products, their ability to determine product costs is moving in the opposite direction. This is neither a formula for success nor a problem the Arsenal can solve by itself.	

---

# SECTION 2

## INTRODUCTION

---

### 2.1 SCOPE

The purpose of the Best Manufacturing Practices (BMP) survey conducted at the Watervliet Arsenal (WVA) in Watervliet, New York was to identify best practices, review manufacturing problems, and document the results. The intent is to extend the use of progressive management techniques as well as high technology equipment and processes throughout industry and government facilities. The ultimate goal of the BMP program is to strengthen the U.S. industrial base and reduce the cost of defense systems by solving manufacturing problems and improving quality and reliability.

A team of engineers accepted an invitation from the Arsenal to review the processes and techniques used in its facilities located in Watervliet, New York. Potential industry-wide problems were also reviewed and documented. The review was conducted at WVA on 13-17 July 1992 by the team identified in Appendix B of this report.

The results of BMP surveys are entered into a database for dissemination through a central computer network. The actual exchange of detailed data will be between companies at their discretion.

The results of this survey should not be used to rate WVA with other government activities, defense contractors, or commercial companies. The survey results have no bearing on one facility's performance over another's. *The documentation in BMP reports is not intended to be all inclusive of the activity's best practices. Only selected non-proprietary practices are reviewed and documented by the BMP survey team.*

### 2.2 SURVEY PROCESS

This survey was performed under the general survey guidelines established by the Department of the Navy. The survey concentrated on the functional areas of design, test, production, facilities, logistics, and management. The team evaluated WVA's policies, practices, and strategies in these areas. Furthermore, individual practices reviewed were categorized as they relate to the critical path templates of DoD 4245.7-M, "Transition from Development to Production." WVA identified potential best practices and industry-wide problems. These practices and other areas of interest were discussed, reviewed, and documented for distribution throughout the U.S. industrial base.

The format for this survey consisted of formal briefings and discussions on best practices and problems. Time was spent at WVA reviewing practices, processes, and equipment. In-depth discussions were conducted to better understand and document the identified practices and problems.

### 2.3 NAVY CENTERS OF EXCELLENCE

Demonstrated industry-wide problems identified during the Best Manufacturing Practices surveys may be referred to one of the Navy Manufacturing Technology Centers of Excellence. They are identified in Appendix C.

### 2.4 ACTIVITY OVERVIEW

Watervliet Arsenal is the 142-acre site home to a government-owned and government-operated manufacturing facility. As a component of the Army Armament, Munitions and Chemical Command, Watervliet's products include tank cannon, artillery cannon, battleship guns, marine drives, scissor bridges, and rocket motors. This 72-building arsenal encompasses over 1.2 million square feet of manufacturing space and employs almost 2,000 personnel.

Watervliet's impressive capabilities allow it to employ the latest manufacturing technologies to support rapid design, development, and testing of new products. It has extensive capabilities in metalworking as well as specialized processes. The Arsenal underwent a substantial modernization program called Project REARM in the 1980s which included building new facilities, procuring new manufacturing equipment, and implementing a new training program. In addition, a computer-integrated manufacturing program was initiated which includes shop floor and above-the-shop-floor systems.

Today, Watervliet Arsenal continues to support enhanced customer service through product and service diversification. It supports the Navy's Manufacturing Technology program, and is pursuing many new programs including the establishment of a teaching factory to extend training for Watervliet personnel and others in industry and academia.

Watervliet Arsenal is also home to the Army's Benet Laboratories, part of the Army Research, Development, and Engineering Center at Picatinny, NJ. Benet maintains the primary mission of development of advanced cannon. Benet performs scientific and engineering activities which range from basic research through design for producibility.

---

They are responsible for the research, design, and development of tank cannon, tank mounts, tank autoloaders, artillery cannon, mortars, recoilless rifles and tank turret items. They also provide engineering support for the production of these items. Benet's collocation with the production facilities at WVA provides an excellent opportunity for concurrent engineering and rapid prototyping.

## **2.5 ACKNOWLEDGMENTS**

Special thanks are due to all the people at the Watervliet Arsenal whose participation made this survey possible. In particular, the BMP program acknowledges the special efforts of Mr. Thomas Fitzpatrick for enabling this survey to occur.

## **2.6 ACTIVITY POINT OF CONTACT**

While the information included in this report is intended to be descriptive of the best practices and techniques observed at WVA, it is not intended to be all inclusive. It is intended that the reader will need more detailed data for true technology transfer.

The point of contact for this BMP survey is:

Mr. Tim LaCoss  
Advanced Technology Design Division  
518-266-4566  
DSN 974-4566  
Watervliet Arsenal  
Watervliet, NY 12159-4658  
FAX: (518) 266-4555

# SECTION 3

## **BEST PRACTICES**

---

The outbreak of peace in the world with the demise of the Soviet Union has resulted in massive cutbacks in defense spending and the reduction or elimination of large segments of military forces. Other changes such as new technologies and future combat scenarios are expected to reduce or eliminate the need for the cannon-related products produced at Watervliet Arsenal. These upheavals in the defense environment are driving the need for rapid change and adaptability at Watervliet Arsenal. Historically, WVA has monopolized the U.S. cannon market. Because of the relatively stable historical demand for cannon products, issues such as future survivability of the Arsenal, product mix, and new market development were not addressed.

Now, however, WVA is adapting for survivability. The Arsenal recently completed a large scale facilities modernization and manufacturing capability enhancement. The Arsenal is also aggressively marketing ordnance to all DoD components, not just the Army. Watervliet is expanding into new market opportunities such as services and selling technology. Because the changes in the global environment and WVA's response to that situation are recent, many of the changes instituted are in the planning or implementation phases. This was a significant consideration factor in the presentations given to the BMP survey team. Many items described as "information" are in actuality best practices that have not been completely implemented. There were many notable best practices at WVA, and the survey team considered them to be among the best in government and industry.

### **3.1 DESIGN**

#### **DESIGN POLICY**

##### **Advanced Tank Cannon Technology Programs**

The Advanced Tank Cannon Technology Program generates and coordinates "high risk" research and development projects that are conducted by Benet personnel. The projects involve technology that is related to existing tank cannon. The goal is to improve current products and to explore technology that can be used in future products. Pursuit of this research/development program over the last five years has produced continuous improvement of current products, without jeopardizing production schedules or

product quality. It is also producing lessons learned that will be applied to future products.

More specifically, the program aims to:

- Improve performance
- Increase cannon life
- Reduce the risk of development and production
- Lower development and production cost
- Enhance reliability of tank cannon.

The projects are pursued outside of mainstream product development. This isolates higher risk investigations – if they fail, the basic product is unaffected—and Benet benefits by learning early what doesn't work. If progress is made the techniques can be implemented quickly since they are applicable to current products.

The program is pursued on a project-by-project basis, typically 10 per year, that are negotiated annually with the sponsor (Tank Main Armament Systems, a separate Army organization). Projects are formulated and executed by principal investigators within Benet Labs. They are coordinated by Benet management to ensure that there is no overlap or redundancy and that results are relevant to the needs of the sponsor.

Some examples of recent past and current technology areas include:

- Advanced materials
- Thermal shrouds
- Bore evacuators
- Muzzle brakes
- Gun dynamics
- Bore plating
- Breech mechanisms
- Muzzle reference systems.

Technology areas investigated are applicable to products currently in production and use. As an example, Benet improved a breech block by performing in-house mechanical analysis of a current design, design of a new breech block (patent pending), and testing of the new design.

---

The continuous investigation of promising technologies that are related to current products, yet decoupled from product production, is a very positive measure to ensure that current products (tank cannon) are improved upon, and that future products will utilize new technology.

## DESIGN PROCESS

### Producibility Enhancements through CAD Tools

Benet Laboratories, Development Engineering Division, has assembled a complete CAD analysis capability that allows exploration of new design concepts. The networked computer system also quantifies fit, form, and functional requirements of new gun and turret designs. This capability was demonstrated by fitting an existing turret with a new gun design.

The Development Division developed expertise in finite element analysis, gas dynamics, and CAD from previous work efforts. These areas were linked through a LAN where geometric information was forwarded from one group to another until design optimization was achieved. The Division also invested in a solid modeling CAD system to allow the designer to complete a number of tasks not possible with previous design software.

The improved capabilities include:

- Complex assembly requirements such as compound interference angles of one assembly component to another can be determined easily
- Mass properties can be generated of all individual or combined components; shaded imaging is available for visual conceptualization of design progress
- Finite element preprocessing capabilities are also available
- A capability to generate a stereolithographic file for overnight generation of a design model.

With the design concept generated in solids, a finite element file is preprocessed and sent over the LAN for the Finite Element Analysis Group and the Gas Dynamics Group to begin their analyses. Both groups access the common finite element analysis geometric file and process the information over the internetwork on supercomputers such as the in-house Convex C220 or the BRL Cray computer. With the analysis complete, the post-processed engineering modifications are made to the geometric model for final optimization. It is at this stage that a full-scale or a model prototype can be generated, ensuring that form, fit, and function will be met.

This implementation has reduced the design cycle, increased accuracy, extended the life and reliability of designs, and has allowed new areas of design optimization to be explored through an enhanced understanding of the design process. There has also been a cost benefit realized from the implementation of this comprehensive computerized design system. Future plans include the purchase of a stereolithographic system which will allow rapid prototyping of new concept designs and enhanced investment casting of small foundry parts.

### Composites Laboratory

Benet Laboratories has developed a composites laboratory to research composite technology and develop the manufacturing techniques to implement composite structures in production. Composites have been used to provide shielding for the hydraulic recoil cylinders on tank guns, and the composite lining on the armor keeps fragments from disabling the gun. The composite bore evacuator used on a 120mm cannon tube reduced the weight over the steel evacuator by 100 pounds. The composite bore evacuator is also easier to produce than the steel version. Prototype composite components are fabricated in the laboratory for prove-out of the concept and to determine the manufacturing process parameters.

This composites laboratory has helped Benet to introduce new designs into the WVA manufacturing process. These designs are more effective and of lighter weight with the added benefit of easier production.

## 3.2 TEST

### INTEGRATED TEST

#### Breech Fatigue Simulation

The Experimental Mechanics Laboratory of the Benet Laboratories is responsible for determining the safe firing lives of breeches for field use. Although the main responsibility is data acquisition for statistical processing, the laboratory also studies prototype designs, correlation of FEM analysis for both new and existing breeches, and fatigue areas due to stress risers on existing inventory. This allows the laboratory to understand and document the fatigue life characteristics of a particular design before it is entered into the fleet.

The simulation of actual loads that the breech mechanism incurs during the firing of a round is generated by hydraulic pressure pulses. The breeches are attached to a short gun tube fixture and placed into the test fixture. The fixture is then subjected to the simulated firing of its designed round by the hydraulic pulse. The system – called a Dynamic

---

Breech Tester – creates the pulses from the action of an air driven hammer that strikes the hydraulic piston within the gun tube. This system allows a round per second to be simulated, thus dramatically reducing test time and costs. Energy from the existing hammers ranges from 18,000 ft-lbs to 120,000 ft-lbs, encompassing the projectile requirements in the current inventory. There are plans to upgrade existing equipment for the next generation of rounds.

The proof firing test simulation program for breech mechanisms allows rapid and cost effective testing of hardware before it enters service and establishes the fatigue life characteristics for service safety.

### Proof Firing Test Simulation

The Proof Firing Test Simulation program conducted by Benet Laboratories at Watervliet Arsenal fully tests a product for fit, form, and function before it receives any added value and is shipped to other activities for further processing or proof firing. Both mortar tubes and the cannon breech mechanisms are hydraulically tested at the same stresses induced by live firing. Possible hydraulic loads are in excess of 100,000 psi. Cannon tubes, however are not proof simulated, they are Proving Ground Lot Accepted (PGLA). With the PGLA program, only one out of seven tubes are proof fired and the rest are accepted on a sampling basis. The rationale for sampling tubes is based on a swaging process performed by passing a .1-inch larger diameter mandrel down the bore. This process is equivalent to approximately 150% pressure over the normal proof firing test which also increases the fatigue life of the tube. Fit and functional testing for breech mechanisms are performed by an automated process using a gymnasticator – or by using a manual process. During this simulation of the loading and unloading of a round, all required forces for the moving components of breech unit are measured and recorded. The gymnasticator was developed in house and simulates the load, fire, and unload sequence for most breeches in WVA's inventory.

Full scale simulation was initiated with the operation of the Acceptance Test Facility (ATF). The ATF has capability to proof-accept a wide range of breech mechanisms, mortars, and components ranging from 60mm M2 mortars to the eight-inch M201A1 Howitzer. Since 1977, over 19,000 items have been accepted through simulation testing with an estimated savings of over \$15M.

The simulation process is also an effective way to screen for production defects. This screening has prompted corrective action to be taken before costs and delays are incurred by shipment for proof firing. These delays can total from six to nine months. After the hydraulic test and the automated gymnastication test or a manual test, the breech units are

broken down, cleaned, visually inspected, and undergo a magnetic particle inspection. With the inspections completed and passed, the unit is ready for shipment to the next step in the process.

This simulation proof testing program has significantly reduced the requirement for live proof firing and its associated testing costs. The process allows problems to be quickly identified and corrective actions taken. Further developments for this process include accepting newer cannon breech designs and automating a number of the database entries.

### 3.3 PRODUCTION

#### MANUFACTURING PLAN

##### Computer-Aided Process Planning

WVA has positioned its Production Planning and Control Division to meet future manufacturing requirements by providing the Division with the capability to quickly produce accurate production routings through the CAPP system. As a module in WVA's Manufacturing Support Computer System, CAPP includes Group Technology and time standards for both machining and bench operations. Specifically, the system includes the following capabilities:

- It is a Variant system that allows for classification of existing production parts using Group Technology. In addition, it provides each production planner the capability to search for similar parts when creating new process plans. The planner then retrieves a similar process plan, modifies it, and save the routing under a new part number. This capability eliminates the "re-inventing the wheel" approach to creating process plans.
- The system allows the creation of new routings based on WVA's existing manufacturing capabilities and the operation being performed in the component's manufacture.
- It uses a standard text to reduce variation in the English language for item description. The system allows the user to search for standard text based on functional words such as mill and drill.

In December 1988, a contract was issued to purchase and integrate CIMTelligence's IntelliCAPP Computer-Aided Process Planning and Group Technology software; Metcutt's MetCAPP Modules for Machine Time Standards; and MTM's Modules for Manual Time Standards with WVA's existing Master Routing and Item Master files. A functional



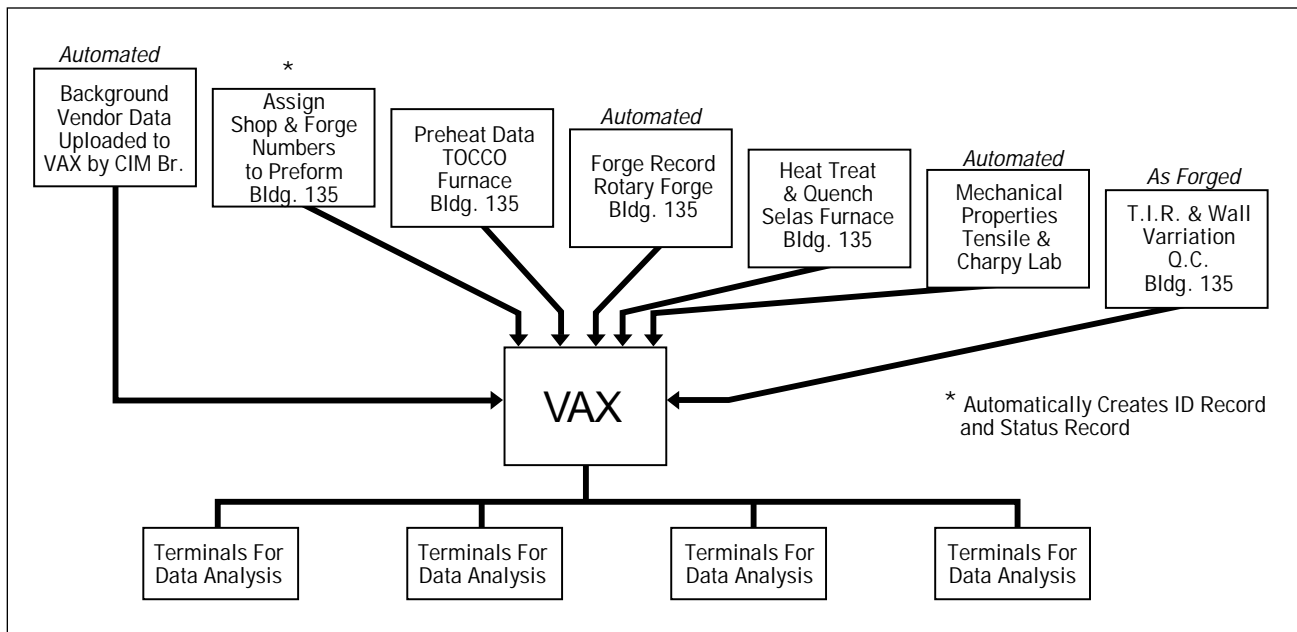

**FIGURE 3-2. PRESENT FLOW OF ROTARY FORGE DATA**

## DEFECT CONTROL

### Predictive Maintenance Vibration Analysis

WVA has initiated a Predictive Maintenance program based on vibration analysis to help avoid critical equipment failures. When the program was instituted in 1985, WVA operated with limited knowledge on this subject; however, it has now established itself as a leader in this area.

The objective of the program is to collect vibration signal data on selected pieces of equipment used in the manufacturing process. The data is then analyzed to determine if there are any abnormalities. This approach allows corrective action to be taken by the maintenance department when early warning signs of a potential mechanical failure are diagnosed. Now repair costs and machine downtime are minimized by having the necessary repair parts pre-staged prior to scheduling the machine for corrective maintenance. Items such as gear mechanisms, drives, and bearings can be easily monitored. Misalignment testing as well as mechanical looseness can also be detected.

WVA has applied over 200 data collection sensor points on critical components of production equipment used throughout the Arsenal, averaging four per machine tool. These points are monitored periodically to gather the data and analyze it before machine failures occur. Because of the success and credibility of this program, WVA is now expanding its application to other production equipment.

The use of this technology has helped WVA avoid unscheduled downtime and production delays and has

improved the quality of the products produced by maintaining the equipment at a high level of efficiency.

### Spindle Live Center Test System

Watervliet Arsenal determined that when the surface finish of the gun tube becomes substandard, it usually results from a variety of machine tool problems. To address this issue, WVA established a program to gather and assimilate data determining that excessive spindle vibrations cause unacceptable surface finishes in the gun tube.

Investigations of the machine tool and spindle performance were conducted through an early ManTech Project. These investigations revealed that there was a causal relationship between the high vibration levels of the spindle and the surface finish produced in the manufacturing process. A portable vibration monitoring system was used to measure a number of internal and external grinding machines. Real time raw data was collected to perform a Fast Fourier Transform frequency domain analysis. A direct correlation of excessive spindle vibration causing unacceptable surface finishes of the gun tube was determined.

Current WVA plans are directed at expanding this technology. A permanent site will house the system and facilitate spindle testing under varying speeds associated with the manufacturing process. This will result in a more realistic analysis of spindle performance and provide a means for checking the quality of spindle repair and balancing performed by outside spindle repair contractors. WVA also plans to establish an electronic fingerprint for each of its

---

grinding machines and to archive this data for future validation and reference. The credibility of the test results will be maintained through the adoption of measurement accuracy criteria traceable to the American National Standards Institute. Watervliet has completed the specification development for this system and expects to start installation in approximately one year.

## Gun Tube Inspection

Watervliet Arsenal defines gun tube straightness in terms of bend from a center line connecting the ends of the bore of the tube to be measured. Methods for measuring straightness in tube bores have progressed from “go – no-go” plug gages to the use of laser technology. The current method used by WVA consists of a laser and photo position sensor or target.

The laser is mounted in the breech end of the bore of the tube to be checked and aimed at the muzzle end. A lateral-effect diode position sensor (target) is used to detect the laser beam position relative to the center line of the bore. The target is mounted on a gage head and positioned inside the muzzle end of the tube. The laser beam is positioned to the center of the target. Once in position, the target is moved through the bore of the tube toward the laser. A computer is used to control the down bore positioning of the target which is continually monitored through a linear encoder. The target is stopped at predetermined positions within the bore by the controlling computer programs. Horizontal and vertical measurements are recorded at each stop relative to the center line of the bore. The entire bore is checked at eight-inch intervals and then rotated 180 degrees to repeat the process in order to collect data for use in determining the effect of gravity – or droop.

The collected data is then analyzed to determine straightness of the tube. Since WVA has determined straightness to be the bend from a center line connecting the ends of the bore, the two measured ends should have a zero deviation. This is ensured by baselining, a procedure that subtracts one end and the component of the slope line between the ends, from each measured position. After all data is baselined, the droop can be calculated and subtracted from the vertical bend profile of the first inspection pass.

Inspecting tube straightness in this manner has helped WVA reduce setup times when checking tubes and also provides a means for accurate checking in the field without having to remove the tube from the vehicle.

## Gun Tube Inspection Station

During the late 1980s, the 120mm tank cannon produced by WVA experienced a significant number of chrome plate adhesion failures during proofing. This problem prompted

WVA to institute fundamental changes in gun tube inspection and manufacturing process controls.

Army policy and the gun manufacturing industry are moving away from the conventional hard gaging and manpower intensive inspection operations. In particular, the traditional manual final inspections have been replaced with statistical process control, continuous process improvements, and coordinate measurement machines. (As a result, less but more complex instrumentation with variable and functional gages is being designed.) These innovative quality tools and techniques have improved manufacturing operations, and reduced costs such as inspection and rework, thereby improving product quality and reliability beyond the traditional or manual inspection means.

WVA designed and built an automated Gun Tube Inspection Station (GTIS) using the central computer controller and commercial electronic gaging systems. The computer – a stand-alone Hewlett-Packard Series 200 computer modified to accommodate inspection of the various gun tube designs – directs and controls the drive mechanism (motor controller) and inspection head. The inspection head is passed through the length of the bore to measure straightness, concentricity, and plate thickness down the length of the bore. Accuracy and repeatability of these measurement techniques are within 5% to 10% of the specification requirements. This improved accuracy, which is permanently recorded, is directly related to the interpretation of electronic signal measurements. The operator can make highly accurate estimates of analog readings but is not able to duplicate the accuracy or repeatability of an analog-to-digital interface attached to a computer.

Since inception of the GTIS, errors associated with chrome plate thickness, bore diameter and bore straightness have been reduced more than 50%, thereby increasing efficiency and accuracy of data for gun tube manufacturing operations while reducing costs.

## COMPUTER-AIDED MANUFACTURING

### Chrome Plate Automated Control and Monitoring System

The problem of chrome loss during proof firing of the 120mm tubes prompted the implementation of a Watervliet Improvement Program. The 120mm gun tube is one application of chrome plating technology at Watervliet Arsenal. Chrome plating of 0.004-inch to 0.005-inch on the inside bore provides corrosion and erosion protection of the cannon tube. Data collection began in the related process areas to determine the relationship and effect on the chrome plating process. The pre-plating processes such as heat treating and honing, as well as the actual characteristics (geometry, chemistry and mechanical properties) of each

---

tube were documented in an attempt to measure each one's effect. The result of the Improvement Program was a significant decrease in the instance of chrome loss during proof-firing and the development of a very robust chrome plating process.

As an additional improvement to the chrome plating process, plans are underway for an automated control and monitoring system. The system will utilize bar code identification of parts and monitoring capabilities for recording temperature, bath level, conductivity, time, date, and tank number. The tank rectifiers will also be controlled so that recipes can be developed and downloaded for each process. The data will be transferred and stored in the VAX computer cluster where the information will be available for analyses, traceability and future retrieval.

## Tensile and Charpy Manufacturing Cell

WVA has designed and implemented a manufacturing cell to produce tensile and Charpy test specimens. These ASTM standard tests (ASTM E8 and E23) are required for each gun tube produced by WVA to ensure that the material has sufficient properties to meet the requirements of the specifications.

Previous methods of manufacturing these specimens required the use of conventional machine tools and had a process time of almost five hours per eight specimens produced per tube. The new cell has reduced this time to less than two hours for the same quantity of specimens.

The cell consists of a Hardinge Conquest '42 CNC turning center, a CT36 Flow International Abrasive Waterjet Cutting System, a Dot Matrix Marking machine along with a digital retrofit on an existing Tinius Olsen Universal Test Machine with a DS/50 Data acquisition system for the Material Test Laboratory. The cell has displaced eight pieces of 40-year old equipment and integrated the new CNC tools to provide an optimum manufacturing operation.

The Material Test Laboratory is located in the same area as the cell and no longer manually computes and records the extensive data required by each individual ASTM test. This process is now automated through a data acquisition process and provides for automatic uploads of the test data to the factory host computer. In addition to the reduced process time, reductions in key punch time for manual data entry and production floor space use were realized.

What was intended to be a means for providing near net shape test specimens has now evolved into increased machine utilization of the waterjet machine. Currently, over 20 additional components ranging from ballistic steel to composite materials have been added to the cell. Each demonstrates significant manufacturing time reductions.

## Rotary Forging Process and Associated Heat Treatment

Watervliet has implemented a rotary forge and heat treating system resulting in notable process time savings, improved forging straightness, minimized wall variation, and enhanced process control. The Arsenal manufactures 105mm, 120mm, and 155mm cannon tubes. Conventional cylindrical forgings previously were purchased to produce these gun tubes. This process began with a solid cast ingot which was rough-shaped on an open-die hot forging press, rough-bored, and machined on the outside diameter to near-net shape. The production and subsequent machining of the conventionally produced forgings was costly and involved significant processing time.

With the rotary forge process, a bored and turned pre-form is heated in the induction pre-heat furnace for approximately one hour to the forging temperature of 2000 degrees Fahrenheit. A transfer car is used to place the pre-form in the rotary forge. A push-type chuck aligns the pre-form and places a mandrel through the center of the pre-form to control the extrusion of the inside diameter. The four radial hammers, each capable of applying 100 tons, are CNC controlled and can accept up to 22-inch diameter billets. The rotary forging process requires approximately 12 to 15 minutes.

After forging, the deformed tube ends are removed in a hot cut-off gear machine and the tubes cooled to room temperature. The horizontal Selas heat treatment furnace sends the tubes through the 12-zone austenitizing furnace on rollers which provides continuous rotating of the tubes and consequently, improved straightness of the tubes. The tubes are radially spray-quenched from the inside and outside diameters and sent on to the tempering furnace. This heat treating system is capable of accepting tubes up to 320 inches in length.

The rotary forge operation is a major electrical power consumer at the Arsenal. A power consumption analysis determined that the monthly billing was based on the peak consumption rate at any point during the billing period. The analysis showed that the major peaks or spike usage periods that formed the billing base occurred during operation of the rotary forge. Consequently, the rotary forge now operates on an off-shift basis to prevent its power consumption being added to the normal operational load, thereby creating a spike. This simple change in operational philosophy has produced a significant savings to the Arsenal.

In the 13 years that the rotary forge and heat treatment system have been operational, several upgrades have been incorporated. Improvements such as the installation of the CNC system and the replacement of the induction pre-heating system have provided for a source of cost-effective, high quality forgings.

## DNC System

As part of the original CIM strategy associated with REARM, WVA instituted DNC in three phases. An initial pilot system of six machine tools and a testbed operation of 84 machine tools was implemented between 1983 and 1986. This included installing the network and DNC on the first 90 machine tools. WVA learned from these initial efforts that standard off-the-shelf hardware and operating system software needed to be used; in-house support requirements needed to be determined; and a flexible but simple report generator and a quality control notification feature were required. Between 1985 and 1987, a specification was developed for an expanded system, and a contract was awarded. Between 1987 and 1991, basic and advanced DNC features were implemented on additional machine tools. There are currently 180 to 190 machine tools tied into DNC (Figure 3-3).

Benefits that WVA anticipated included:

- Eliminating associated costs of tape preparation and loading
- Improving NC program distribution management and revision control
- Minimizing part program prove-out time
- Eliminating tape reader maintenance
- Reducing machine downtime.

In addition to these benefits, the Arsenal wanted to capitalize on using a machine information system, allowing operator edit under certain conditions, and providing graphic display of the cutter path.

DNC adds another dimension to shop communications. In normal operation, a DNC user pulls down a catalogue of mail and/or part programs already downloaded to the DNC terminal with an assigned status. The available status flags are QA (program is ready to run as is), or TR (the machinist must call a programmer to the machine so the program can be proved out). Utilities are available to download a needed program to the DNC terminal. Part programs are released from the programming area into the DNC system (NCAM by GE-FANUC) in a batch mode once an hour, but a remote download directly to the machine can be performed if necessary. If the operator edit mode is entered (a password must be used), a flag is raised through a mail message to the programmer. These edited programs are marked distinctly on the catalog listing, but only the latest edited program is available to the machinist. If an earlier edited version is desired, the machinist must erase all edited versions and begin from the last QA version. This feature ensures the machinist is careful when editing a program.

The Operations Directorate has established the procedures and responsibilities for shop (operator) editing of NC part programs by means of the DNC computer system. To facilitate implementation of this procedure, the editing capabilities are locked by means on the machine controller, although feed and speed adjustments are still allowed once

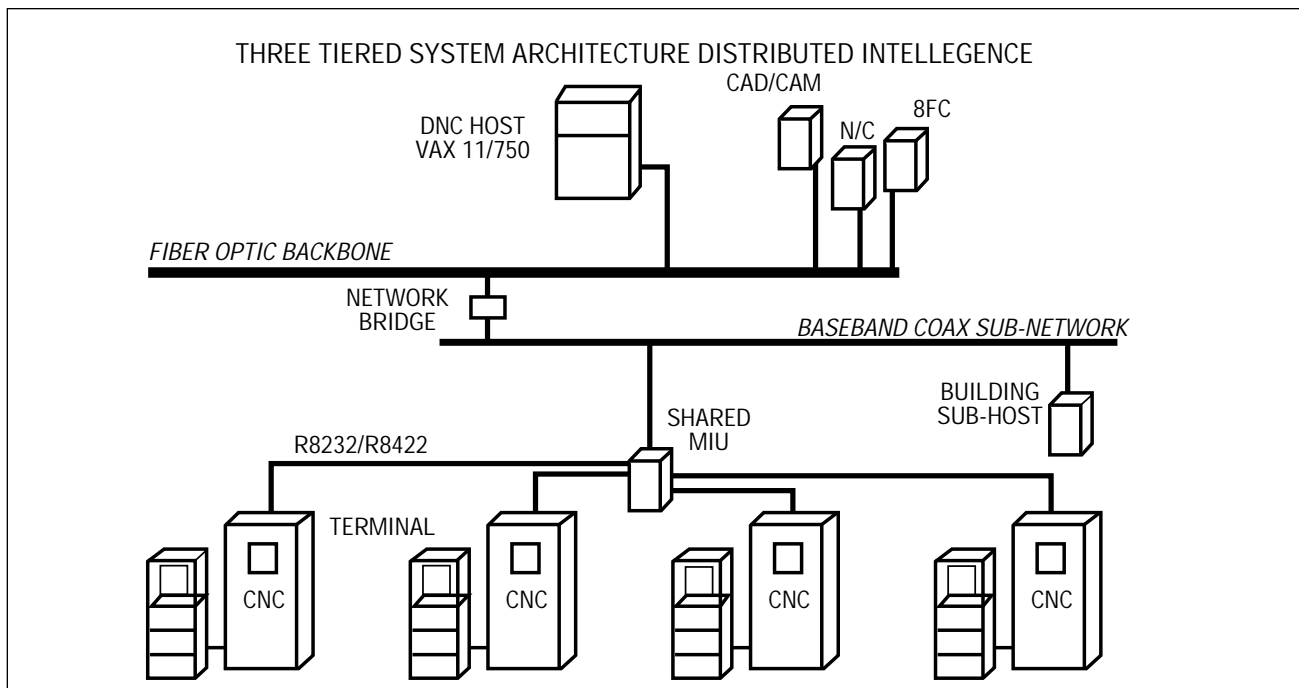

**FIGURE 3-3. DNC SYSTEM ARCHITECTURE**

the program is loaded into the machine controller from the DNC terminal.

Local modifications have been made to the GE-FANUC system running on DEC equipment by WVA's CIM staff. Plans are underway to investigate state-of-the-art prototypes for potential upgrades.

### 3.4 FACILITIES

#### MODERNIZATION

##### Acquisition Monitoring System for Renovation of Armament Manufacturing Project

The modernization of Watervliet Arsenal through the Renovation of Armament Manufacturing (REARM) project included the purchase of over three hundred pieces of equipment. To monitor and control these acquisitions, a computer software system called the Acquisition Monitoring System (AMS) was developed to aid in tracking the procurement actions and associated scheduling.

The software system, a specially tailored version of IBM PMS4, works as a management tool to plan, forecast, and coordinate the workloading for the equipment deliveries, building completion, relocations and foundation construction. Continuous tracking of procurement actions ensures

that funding is obligated in the appropriate fiscal year. The PERT-based system allows schedule comparisons to be made between predicted and actual dates so that resources can be realigned as required.

The management of the AMS required a close working relationship be maintained between the involved organizations; consequently, weekly status meetings were held to discuss problems and solutions. The AMS provided a way to retrieve the necessary information for high-level briefings and was an effective tool in managing the facilities modernization.

#### PRODUCTIVITY CENTER

##### Manufacturing Support Computer Center

As a portion of Watervliet Arsenal's REARM Project, the Advanced Technology Systems Directorate was established in 1985 to procure almost \$40M in CIM systems. As these systems became available, they were handed off to the CIM Branch of the Production Planning and Control Division in the Arsenal Operations Directorate (AOD).

The CIM Branch provides administrative and support services needed to effect implementation and continuous improvement of installed CIM technologies (Figure 3-4 and Figure 3-5). Industrial Engineers, Mechanical Engineers, Computer Scientists, Industrial and Computer Technicians

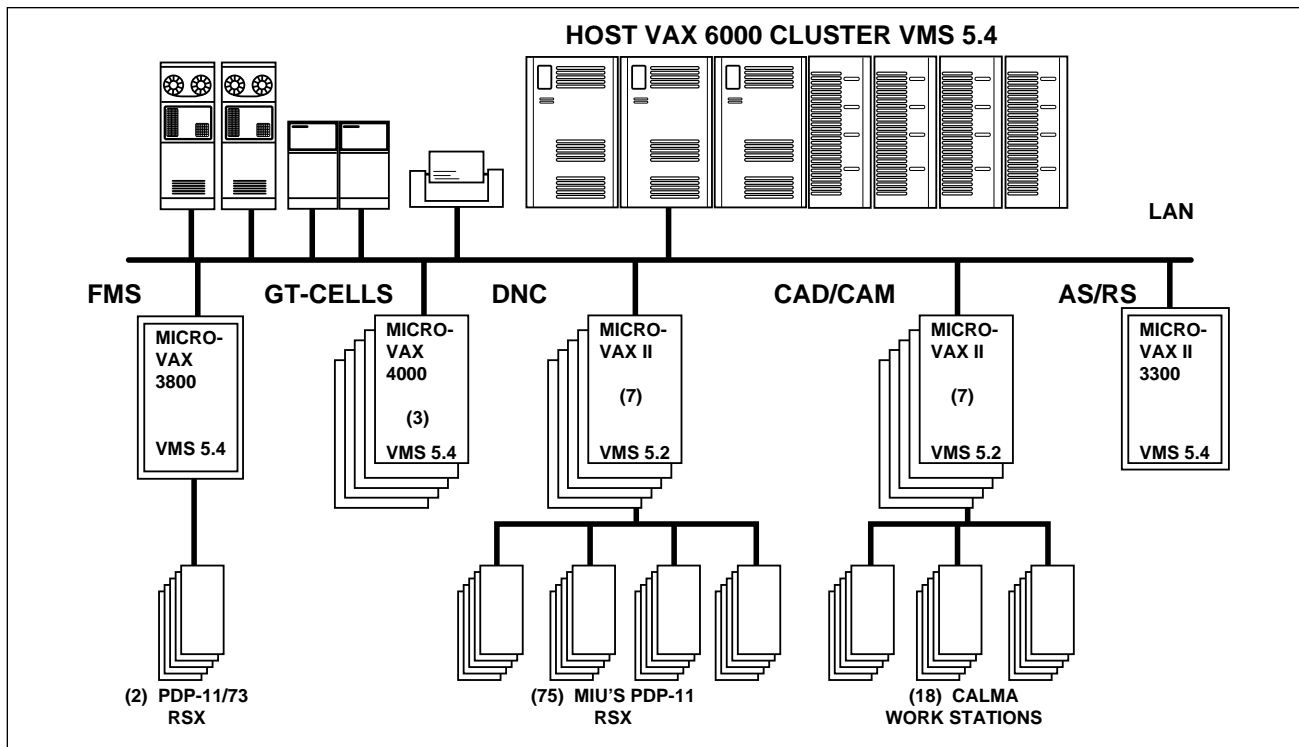
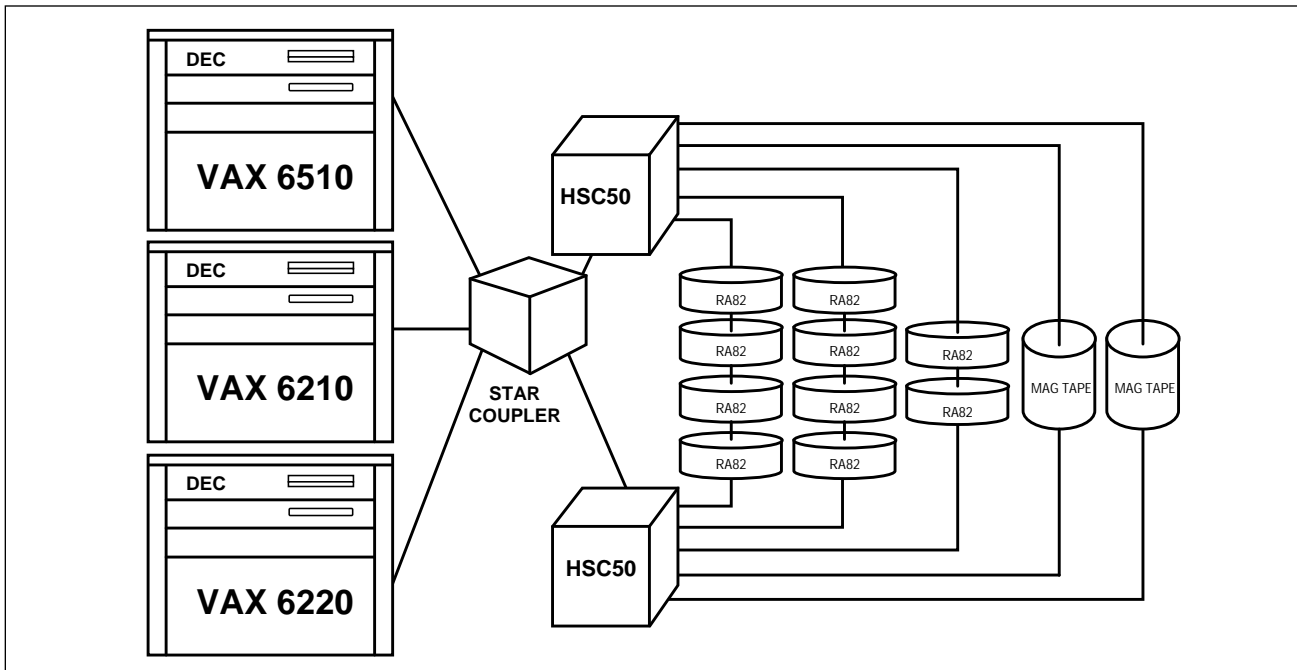

FIGURE 3-4. AOD HARDWARE CONFIGURATION



**FIGURE 3-5. AOD COMPUTER CENTER CLUSTER CONFIGURATION**

and Computer Operators staff the CIM Branch in support of this effort. Supported systems include CAM, Computer-Aided Process Planning (CAPP), DNC, Numerical Control Part Programming, Tool and Gage Management Systems, Materials Requirement Planning, portions of a Shop Floor Control System, Computerized Maintenance Management System, and Source Data Collection System.

The CIM Branch opted to become a Digital Equipment Corporation computer shop to support WVA's strategic plan. Several integration issues were therefore avoided since the computer shop was homogenous. In addition, a solid foundation was established for future upgrades and enhancements. When the software packages were procured, provisions were made for the acquisition of any source code if the vendor became defunct. Yearly maintenance fees for all systems – hardware and software – is almost \$2M.

Anticipated plans for this Branch include an AOD Computer Center Upgrade – hardware upgrades to the manufacturing VAX cluster to include a VAX 6620, three gigabytes of additional DASD, and a high speed laser printer; management techniques for Distributed Computing Environment; CIM Database Integration – an ongoing optimization of installed systems through data integration; and Client/Server Architecture and Open DBMS – because of increasing user demands to exploit desktop systems and access of mainframe data, system re-engineering to DBMS, data access tools, and software (pathworks, UDMS, and VAXlink) will be addressed.

## Database Managers Reference Guide

With the implementation of a CAPP system in 1989, a software package from Metcutt was applied, requiring databases of equipment, tooling, and tooling components to be built. The databases include extensive descriptive data for compatible feeds, speeds, tooling inserts, tooling holders, machines and processes determinations. However, the data provided by various suppliers of these components was not the data needed by the Metcutt program for WVA to have full confidence in the program outputs. Therefore, a MetCAPP Utilities Database Managers Reference Guide was produced in a little over three months. This guide facilitates consistent data input and interpretation. It is also used as a means of communication between various suppliers and their customers.

## 3.5 LOGISTICS

### TRAINING MATERIALS AND EQUIPMENT

#### Apprentice Training Program

WVA has made an intensive, visionary commitment to development of highly qualified, journeyman-level talent. This program is an integral part of a progressive, in-plant training program with courses in a wide variety of areas. The WVA Apprentice Training Program provides trade training for machinists, heat treaters, electronic industrial

---

control mechanics, and production machinery mechanics. In addition, courses of study have been established in numerical control.

The courses are conducted in-plant by the Hudson Valley Community College, and consist of 960 hours of formal instruction over a four-year period. This arrangement provides ready acceptance of course credit toward a trainee's Associate Degree.

WVA's commitment is manifested in the well-organized apprentice area for machinists, and new, state-of-the-art CNC machine tools specifically dedicated to training. The NC training facilities consist of eight NC machine tools (two lathes and six mills) which are fully functional DNC-linked tabletop units. Students are able to master all of the essential skills without the intimidation of a large machine. Full-sized machining centers and a slant-bed turning center are also totally dedicated to this training effort.

### **3.6 MANAGEMENT**

#### **MANUFACTURING STRATEGY**

##### **Total Quality Management Program**

The Total Quality Management Program at Watervliet Arsenal consistently applies objective, analytical problem solving to all levels of management thought and action, from strategic planning to factory floor operations. It is used to look for patterns of individual problems as symptoms of underlying system weakness. WVA can then build solutions into the basic operational fabric and systems of the Arsenal.

The program evolved out of early SPC analysis that showed how quality problems often occurred in clusters. For example, when purchased tooling was identified as a recurring cause of defects, system changes were made that included both procurement process and organizational assignment modifications.

As the program has matured, it increasingly emphasizes system improvements rather than isolated adjustments that could have unanticipated consequences. SPC analytical methods have been directly linked to the values and requirements of the Arsenal's customers in a continuing program led by one staff person with the support of top management. This person uses analysis and persuasion to induce operating managers to make improvements in their own best interest. Changes grow from within rather than being imposed from above.

As the TQM program is implemented, it builds a common understanding of causes and effects that cross functional lines, and as such, it is an integrating force. It appears to

build an acceptance of continuous management system improvement as a routine manufacturing task.

##### **Enterprise Level Strategic Plan**

WVA is adapting for survivability in response to recent global political changes. These changes include the end of the Soviet Block as well as new technologies and future combat scenarios that are expected to reduce or eliminate the need for cannon related products. International competition is increasing as well.

As a result, WVA recently completed a large scale modernization of facilities and manufacturing capability called REARM. The Arsenal is now aggressively marketing ordnance to DoD components other than the Army. Recent changes in U.S. laws are permitting WVA to enter the commercial marketplace although there are still significant limitations and restrictions. WVA is also expanding into new market opportunities such as services and selling technology.

These efforts have mandated the need for enterprise level strategic planning. The process began over a year ago with the Arsenal's executive board receiving training in strategic planning. Porter's Five Forces Model was adopted for identifying and analyzing the forces driving industry competition in WVA's current and potential markets. Forces that were considered included the bargaining power of suppliers and buyers and the threats imposed by new entrants to the markets and substitute products or services.

The process to develop a strategy focused on a number of key elements requiring input on such items as vision, goals, objectives, capacity analysis, marketing analysis, and long range forecasting. The executive board held an off-site conference to assess strengths, weaknesses, opportunities, and threats. In addition to their own resources, outside assistance was used such as studies by the Industrial College of the Armed Forces, and the New York State Center for Economic Growth.

The vision that emerged from the process was that of a new Arsenal as a fully capable multi-purpose manufacturing and machining enterprise that will become the supplier of choice for the Navy, Air Force, and Army as well as foreign military and commercial customers in key product areas. Also identified were new opportunities for expansion into professional services, sales of technology, and the development of new core competencies such as composites and ceramics.

To implement the strategy, the Arsenal has reorganized into three major interacting systems – the Producibility System, the Acquiring System, and the Equipping System. The Producibility System is centered around Benet Laboratories

---

and serves as the agent for design for producibility. The Acquiring System is the procurement function and involves all activities from the placing of orders by the customer to final delivery of product. The Equipping System is the operations department which provides the means such as people, machines, and other resources, to produce the products. A customer service organization was formed to fill the new requirement for a marketing function.

The product of this strategic planning process is a living plan that is continually reassessed and updated. It is shaping and guiding the large scale and sweeping changes currently implemented at WVA over a relatively brief period of time. It is the key to the Arsenal's survival and prosperity in the next quarter century.

## Advanced Contracting Methodologies

The Procurement and Contracting Directorate is developing systems to meet the needs of the DoD logistics system and possible commercial markets for rapid response. These systems are consistent with the WVA strategic plan. At the same time, the Directorate is making changes that save the Arsenal money and improve its performance today.

Having stratified procurement problems by cost and time loss to WVA, the Directorate is running a series of programs which include consolidated contracting, requirements contracting, best value contracting, blanket purchase agreements, option for subsequent year contracting, a stronger emphasis on liquidated damage, data communications to local vendors, and improved vendor relations. They are also tracking changes in vendor-related quality problems.

The Directorate has recognized that procurement will be the greatest limiting factor in reducing Arsenal response times. They are constantly finding ways to save time within the existing regulatory framework and are actively seeking more discretion and latitude. As a result, WVA could become an excellent test bed for the DoD-wide FCIM Program which is working toward a 30-day response time for obtaining spare parts.

## Improved Maintenance Performance and Control Thrust

For the past few years, the maintenance organization within WVA has been focusing on a number of initiatives to improve performance and control. These initiatives were being implemented independently and without a directed focus. Lack of prioritization of project efforts resulted in insufficient resources to adequately support all the improvement initiatives that existed.

The Improved Maintenance Performance and Control Thrust (IMPACT) Project was initiated in January of 1992 to focus top level planning and bring maintenance initia-

tives into existence in a controlled, structured, and efficient manner. Project management techniques were applied to structure overall planning efforts, prioritize projects, develop strategies for continuous improvement, document cost saving measures, and develop new project efforts.

To date, over 15 major project initiatives have been defined. Weekly meetings are held to maintain status updates. Detailed monthly progress reports are distributed. Software control modules have been implemented. New project initiatives are in development and continuous improvement efforts are underway in all existing projects. The directed project management focus of Project IMPACT has leveraged the resources of the maintenance department in a very effective way to better support the overall operations of the arsenal.

## Rapid Parts Prototyping and Production Using Flexible Computer-Integrated Manufacturing

WVA has demonstrated that it can provide a quick turnaround capability in the production of critically-needed parts. This capacity is part of the new DoD program entitled Flexible Computer-Integrated Manufacturing (FCIM). The FCIM program is a logical evolution of several rapid turnaround replacement parts manufacturing cell programs brought on line in the 1980s, including the Army Rapid Acquisition of Spare Parts, the Air Force Spare Parts Production and Reproduction Support , and the Navy's Rapid Acquisition of Manufactured Parts.

The emphasis of the FCIM program is on tying various pieces of computing and flexible automated processes together across multiple sites and streamlining the procurement process. The goal of the FCIM program has been to reduce the more than 300-day turnaround for out-of-production spare mechanical and electronic components to 30 days or less, from initiation of order to customer delivery.

WVA has demonstrated its capability on a number of recent projects including production of a spur gear for an F-16 fighter aircraft. Between WVA, Air Force Logistics Center San Antonio, and Naval Ordnance Center Louisville, the product was completely reverse-engineered using a laser scanner, modeled and analyzed on a CAE system, rapid-prototyped using stereolithography, investment cast, and completely turned, gear-shaped and finished using the CAM data generated from the CAE database.

FCIM was heavily used during the Persian Gulf conflict, rapidly providing critically needed parts to the conflict zone. This approach can provide industries the capability to rapidly develop and test prototype parts, and provide customer spare parts support long after a product and its component inventory are depleted.

---

## Customer Program Development and Service Office

To enhance customer service as well as plan and develop business strategies for the future, WVA has established a single customer service organization. Prior to the organizational change, marketing opportunities were not recognized, and marketing actions were often redundant and usually conflicting.

Recognizing the continuous change in its social, technical, and economic environment, and the need to stay current with its ability to serve customers through Arsenal systems, the WVA Commander established an objective of better service to customers as well as creation of a more in-depth business planning and development program. To meet this objective, the Arsenal established a single customer service organization to include responsibilities for business planning and development, marketing and strategic planning, and processing and overall management of quotations and firm customer orders.

The Customer Service Program became operational in April 1992. The office was the merger of the Procurement Division and the Order Processing Section. Activities were implemented to improve response time, and additional positions such as a point of contact to coordinate the business planning development and marketing effort were instituted. The new office staff includes 30 personnel.

Expectations for this organizational change are high, but it is too early to provide measurable results. Customer feedback has been favorable, marketing opportunities have been easier to coordinate, and responsiveness to the customer has been shorter. WVA continues to anticipate measurable improvements as the result of the Customer Service Program.

## PERSONNEL REQUIREMENTS

### Self Assessment Program

WVA's Self-Assessment program has proven to be a useful and powerful tool for identifying areas that require improvement and need formal executive focus. The Self-Assessment Program was initiated in August 1990 in an effort to become certified by the Army's Contractor Performance Certification Program and the Continuous Process Improvement Program. Both programs provide criteria that must be assessed in the areas of management policy and metrics, design producibility, materials inventory and suppliers, and manufacturing process control and response to problems.

The initial assessment indicated that WVA had digressed from some basics in all areas of operations, and improve-

ments were necessary in order to be certified. Therefore, a formalized Self-Assessment Program was established in January 1992 with a Task Manager to track specific improvement efforts. Assessment techniques were developed to address each of the four areas. A Process Improvement Team was developed including five managers and shop personnel with multifunctional expertise. The team followed continuous improvement criteria consisting of conducting interviews, in-shop audits, and compiled documentation to identify problems, solution, and tasks.

The extent of the Process Improvement Team's assessment focused on such major areas as expanding the use of SPC, improving process control and planning, building better relationships with suppliers, and providing sound quality data analysis in support of suppliers.

In the short time since first initiating the Self-Assessment Program and the establishment of the Process Improvement Team, tasks have been implemented that reduced scrap by 34% and rework by 45%.

## DATA REQUIREMENTS

### Process Control Discipline: Guideline and Improvements

As the result of an unfavorable five-year trend in scrap, repair, and rework, WVA initiated a baseline assessment of its organization in December 1991. Findings in the area of manufacturing operations included that outdated procedures were in effect; procedures were not being followed; untimely and undocumented corrective actions were occurring; and there was an emphasis on reporting defects rather than preventing them. Consequently, most errors were not discovered until a later manufacturing operation or final inspection. Delayed discovery also made root cause determination difficult to assess which increased the probability that inadequate corrective action was taken.

This baseline assessment resulted in the implementation of a Process Control Program based on well-defined procedures and employee discipline. The program includes such initiatives as written process control guidelines for employees and supervisors which empowered operators to terminate operations producing non-conforming parts until the situation was corrected. The guidelines eliminate reliance on inconsistent verbal orders and stress adherence to procedures. Process improvement teams were formed for key processes, and a team was formed to investigate and report on quality problems in the areas of high dollar value scrap, repair, and rework, producibility and design issues. The SPC staff has been increased and the number of operations being charted has increased by 30% in the past six months. More than 60% of the operations being charted now have a

---

process capability of one or greater. Other results include a 35% drop in scrap, a 25% reduction in repair activity, and a nearly 60% reduction in rework.

Future actions will involve implementing procedures for process controls using fixtures, NC programs, or tooling

when characteristics cannot be operator inspected; increasing the use of SPC charting by a factor of five; and process control training for process and quality planners, process improvement teams, and all supervisors.

# SECTION 4

## INFORMATION

---

### 4.1 DESIGN

#### DESIGN PROCESS

##### Engineering Support in Production Mission

The Engineering Support in Production (ESIP) program at WVA, developed through Benet Laboratories, integrates three major support functions that are basic to the manufacturing process. These categories are critical to a successful manufacturing effort.

*Configuration Management* is responsible for maintaining the technical data package (TDP) of all currently fielded cannon systems. This documentation control ensures that material defects, improvements in material defects, maintainability, and producibility are controlled.

*Support to Manufacturing* helps resolve design and process related manufacturing problems. This effort refines the manufacturing process as it relates to reliability, improved quality, enhanced producibility, reduced time and costs, and minimized potential production problems.

*Testing Support* provides on-site engineering assistance during testing of redesigned or modified systems and components. This program's objectives include system durability, as well as determining reliability, safety, and maintainability through logistic support.

The impact of the ESIP program has led to an increased understanding of the overall design and manufacture process from cradle to grave. It has also provided favorable changes in costs, quality, and time to market of all systems where it has been used.

#### DESIGN ANALYSIS

##### XM35 and XM291 Programs and Development of XM91 Autoloader

Benet Laboratories is responsible for the primary design and manufacture of prototypes, and redesign of production items variations based on prototype test results. Benet recently established goals for three programs it is developing – the XM35, XM291 and XM91 Autoloader.

- The XM35 (105mm gun) development program will improve the existing M68 gun. Performance goals for the XM35 include weight reduction, recoil impulse reduction, same accuracy as M68,

use of current 105 ammunition, front gun installation for easier maintenance, field replaceable recoil cylinders, and a powered block opening to accommodate the Autoloader currently under development. The XM35 program development includes design, analysis, testing, and generating the TDP for manufacturing production.

- The XM291 gun program will use enhancements developed by WVA and Benet to improve gun performance. Compatibility for refit to the M1A1 tank is another design requirement. Gun enhancements include improved breech design, thermal shroud, improved recoil design, and the new feature of recoil distance measurement.
- The XM91 Autoloader program recently conducted and completed Advanced Tank Cannon (ATAC) System vehicle testing. The Autoloader automatically takes rounds from tank storage areas and loads them into the breech of the tank gun – this was previously a manual operation. In the future, the Autoloader will also support automated replenishment of the tank's ammunition from a supply vehicle. Development has involved mechanical design and analysis, development of control algorithms, and control system design. The project also involves extensive prototype testing. An innovative feature of the Autoloader is control of projectile loading velocity by gripping the shell and controlling its acceleration and deceleration.

These programs highlight Benet's versatility in design, testing, prototype manufacture, and knowledge of manufacturing considerations.

#### PARTS AND MATERIAL SELECTION

##### Gun Barrel Plating Studies

Benet Laboratories has several chromium coatings under research and development. Chromium is a good refractory metal coating because it is extremely hard with a high melting temperature (1875 degrees C) and provides excellent resistance to wear, erosion, and corrosion. The use of electrodeposits such as chromium plating and refractory metals to protect ordnance materials is an established

---

industrial practice. Refractory metals are used to protect gun barrels from the erosive and corrosive environment inside a gun tube after firing. When the projectile is fired, extreme temperatures, pressures, and gases are produced near the breech end of the gun. These conditions, coupled with stresses, expose the gun barrel to extreme friction, wear, erosion and corrosion.

High contraction (HC) chromium is one of the best materials currently available for protecting the bore surface of gun barrels. For corrosion protection, a softer, crack-free electrodeposited chromium coating – called low contraction (LC) chromium – has been developed by Benet. LC chromium shows negligible contraction after heating, and since it is stronger and contains few cracks, is more suitable than HC chromium for protecting a metal against wear and erosion. Benet has several other chromium studies underway including HC/LC laminated chromium coatings, chromium/refractory metal alloy electrodeposition and pulse plating.

The refractory metals have extremely high melting points. Once molten, the salt acts as the media for ion transport. Currently, the molten salt laboratory is studying the electrodeposition of tantalum and tantalum-chromium alloys. Benet Laboratories' goal is to find the material/process which will provide coatings with the highest erosion and thermal protection.

## **COMPUTER-AIDED DESIGN**

### **Concurrent Engineering; Computer-Aided-Logistics Support; PDES**

Concurrent Engineering, Computer-Aided-Logistics Support and PDES are new efforts for the Watervliet Arsenal. They comprise a coordinated effort by WVA to develop computer-based product data systems to facilitate information flow and close interaction among the Arsenal's components.

These three, closely related programs are projected to be part of larger efforts, and their rate of development is therefore largely influenced by national and international standardization processes. The Arsenal is well represented in these standardization efforts and is committed to using the products as they become available. In a dynamic pursuit beyond waiting for standards, WVA is an active participant in multi-organizational tests and demonstrations. It is also developing interim systems for its own use and to simplify communication with local suppliers.

In consideration of WVA's size, this aggressive effort should allow it to be among the first to realize benefits of major national systems improvements as they become operational.

## **4.2 PRODUCTION**

### **MANUFACTURING PLAN**

#### **Combined Gun Tube Straightness Technology**

Based on WVA's Program Management support for the M1A1 ABRAMS Main Battle Tank, efforts are underway to improve manufacturing processes used in the production of the 120mm M256 gun tubes to reduce or eliminate straightening. These efforts include improving the heat-treating process, and measuring in-process gun tube straightness and implementing a no-press procedure. This effort is projected to be implemented within six months if the resources are provided.

Approximately \$10M is being budgeted during FYs 94-96 to development improvements in or replacement of the existing horizontal heat treat process. Enhancements to the existing heat treatment system would provide a walking beam furnace to stabilize the tubes at elevated temperatures. Based on these improvements, WVA is developing a specification for a new horizontal heat treat system to supplement or replace the existing system. These added resources will enable WVA to improve straightness of gun tubes after heat treatment.

The second part of this effort includes developing an improved process for measuring in-process gun tube straightness and facilitate implementing the no-press procedure. Enhancements include adding a hollow spindle lathe to provide accuracy while measuring straightness. This improvement would eliminate the pressing operation which is required four times, at one hour for each operation.

#### **Quick Response Manufacturing**

During the Desert Storm operation, a need for a more capable bomb to destroy deeply buried reinforced concrete bunkers was identified. The lead for this effort was assigned to Eglin AFB with Lockheed providing design support. To meet the time frame established, this teaming effort quickly expanded and eventually became a consortium of activities to provide all expertise and capabilities. The initial contact with WVA centered on the availability of gun barrels that might be utilized as the body for the bomb development effort. A quick check of assets in house determined that the barrels that might be appropriate for this effort were on hand. Operating from telephone instructions and sketches, Watervliet personnel began the process of converting gun barrel tubes to bomb housings. Twenty-three days after the initial call, the first units were delivered for test and WVA had established its position as a critical team member of the consortium.

---

The program was successful because the skill, tooling, facilities and material were available to do the job; there was a single point management established; communication was active at all levels; there was enhanced cooperation among all members; transportation was available when needed; and because there was no opportunity for rework, everything was done right the first time.

## **PIECE PART CONTROL**

### **Development of Shop Floor Control System**

WVA learned valuable lessons in developing its shop floor system and submitted the following information for consideration by companies evaluating similar approaches.

In May 1988, WVA embarked on an aggressive automation effort for shop floor control. This system would combine the functionalities of MRP/MPS, Finite Capacity Scheduling, and Tool and Gage Management with full resource checking capability. With the exception of the Tool and Gage Management System, this effort failed.

The development plan called for migration of shop floor control from a manual to an automated system. Several goals were very ambitious. The evolutions planned ranged from an ability to provide rough cut capacity check for labor only to finite capacity for all resources. The introduction of MPS/MRP and finite capacity scheduling at the same time was impossible to incorporate simultaneously.

Inadequate systems architecture provided another problem. The existing manufacturing systems were not equipped to adequately support data requirements of an integrated manufacturing information system. Project manager turnover was also a major problem during this time. Three different managers were responsible for this effort during a three year period. This lack of continuity contributed to an over-reliance on the contractor and poor interaction with the end user.

Contractor response problems stemmed from a lack of experience with the software chosen and limited systems integration knowledge. The selected bidder's proposal was one-half the next estimate, and the company had demonstrated poor performance on previous contracts. Procurement procedures in place failed to prevent this contract from being accepted.

WVA has reassessed its plan and has implemented a more realistic schedule for accomplishing shop floor control. The decision was also made to terminate the original contract. The new plan offers a phased approach to implement MRP building on the successes, and eliminate finite scheduling at this time. To ensure success, WVA is pursuing sole source of recognized expertise for the chosen MRP system.

To facilitate system ownership, the project management and implementing responsibilities for this effort were transferred to system end users.

## **TOOL PLANNING**

### **Development and Implementation of a Tool/Gage Management System**

Prior to the development and implementation of a tool/gage management system initiative, WVA was using manual methods to control tools and gages used in its manufacturing programs. Problems experienced included delays in getting the right tool to the job (20% of schedules missed); difficulty in interfacing with three separate databases; generation of duplicate tooling; restricted traceability; and utilization was labor intensive.

To solve these problems, WVA established a joint WVA/contractor team to develop and implement a Tool/Gage Management system. This team included a tool specialist and gage specialist from WVA and a program manager and software programmer from the contractor. The original proposal specified commercial off-the-shelf software. Following a site visit and research into the needs of the active users, the proposal was changed to specify custom-developed software and the plan was modified for Arsenal-wide implementation; to delay inventory until after implementation; and to provide 24-hour coverage.

A phased delivery program for software revisions was established allowing for exhaustive review to perform transaction validation, edit checking of ranges, and evaluate suggestions for improvement. Data conversion from the existing method to the automated system presented many challenges including integration of three separate files; inconsistency in numbering schemes; duplicate drawing numbers; format conversions; lack of crib specific location records; lack of accurate quantities between files; lack of dedicated programming staff; and no pre-conversion edit checking.

To ensure that data conversion was accurate, an exhaustive verification process for all data fields was established featuring multiple download and iterative program fixes.

The system design was conceptualized with the user requirement in mind. Users include tool/gage administrators and specialists, crib attendants (eight sites), warehouse workers (three warehouses), metrology specialists (five sites), and tool room workers. Needed features were issuing and receiving, stock locations, allocation to site, inventory gains/losses, scrappage, purchase order status, reorder/restock levels, and calibration recall notices.

A pending Post Investment Economic Analysis will include the benefits of inventory visibility, timely processing,

---

improved accountability, enhanced service, single database, complete inventory management, and a menu-driven, user-friendly system.

## Computerized Maintenance Management System

WVA recognizes that equipment must be maintained in good working condition to safely produce a quality product on time, at the right price. The Maintenance Branch activities were studied to determine what was needed to maintain the equipment more effectively. After the as-is study was complete, an extensive market survey was performed by Advanced Technology and the users to determine the best fit for organizational needs. A specification was then drafted with WVA's requirements included.

Under the old system, there was no spare parts inventory management system. WVA was not aware of the amount of inventory on hand. Each maintenance supervisor had parts he knew he needed to maintain his area of responsibility. There was, therefore, tremendous duplicate inventory. Also, the maintenance system was developed in-house in 1984 and had very little room for expansion and integration, and was costly to maintain.

A contract was awarded to Diversified Engineering Inc. to purchase the System Works MPAC maintenance and stores software. This system was determined to be the correct choice as it integrated the inventory with maintenance. WVA is currently in the implementation phase and although two problems have been encountered during this implementation phase (user acceptance, and identifying, consolidating, and counting the inventory on hand), it is expected to be accepted in December 1992.

When this new software is implemented, WVA's maintenance department will have a state-of-the-art computerized maintenance management system and be more prepared to pro-actively react to manufacturing needs.

## COMPUTER-AIDED MANUFACTURING

### Automated Statistical Process Control

The need for an automated SPC program was identified at Watervliet Arsenal and a cross-functional team of quality assurance, quality control, computer integrated manufacturing, advanced technology, and manufacturing personnel was established. The application of SPC at Watervliet Arsenal is currently limited to manual charting techniques which can be time consuming and result in errors in calculations, missed data, and incomplete or incorrect charts. When a PC/VAX database post process analysis is performed, it provides little or no supporting information for

the operator and only provides evaluation after the fact. Automated SPC eliminates these problems and can provide near real-time process control information at the machine.

From the cross-functional team, the requirements from a user's standpoint of an effective automated SPC program were defined, a market survey of existing solutions was conducted, and site visits were made. The systems were evaluated for functionality, hardware compatibility, CIM integration capability, and several other evaluation criteria.

The specification development for the automated SPC project is underway and approximately 20-30 processes have been identified as automated SPC pilot program candidates. Some of the anticipated benefits from the implementation of this automated SPC program are decreased labor costs associated with charting and data entry, immediate operator feedback, automatic management reports, fast engineering evaluation and reduced scrap, rework and repair.

### Information Systems Modeling

WVA has extensive plans for an integrated manufacturing information system. It will enable efficient data sharing among a wide variety of organizations within the enterprise. The system has been designed using five architectural perspectives including Scope (a business plan), a business model, an information systems model, a technology model, and detailed representations of the architecture.

This has translated into several current initiatives, including a real time shop floor control system, a paperless order entry system, and specifications for an object-oriented virtual corporate database. Also, the actual implementation has seen the development of a LAN which uses a DECNET TCP/IP running on Ethernet.

### Hazardous Material Accountability

New York State waste minimization laws and Watervliet Arsenal hazardous waste minimization goals both require a 50% reduction in the generation of hazardous waste. To meet these requirements, a Hazardous Materials Management program was developed in conjunction with the selection of a Hazardous Waste Minimization (HAZMIN) program.

WVA tested many commercial software products and made the final selection of the LogiTrac HAZMIN software. This software includes inventory tracking of all chemicals throughout the manufacturing environment from the loading dock through each user until the chemical reaches the waste stream. A users log in consumption or movement of chemicals allows exact quantities and locations to be identified. The on-line database contains Mate-

---

rial Safety Data Sheets for all actively used chemicals as well as a system for archiving chemicals which are no longer used but by regulation are required to be on file.

Any employee can access the system to investigate a chemical's potential hazards, personal protection equipment requirements, and exposure precautions. State and federal requirements governing the HAZMIN program are also contained in the database. The system can be used in training all personnel involved with handling hazardous waste and can aid firemen in dealing with hazardous spills or taking precautions when potential explosions are encountered.

By December 1992, all Army installations will have a Hazardous Minimization Standard System and Watervliet Arsenal has been selected as a Beta Test Site using the LogiTrac HAZMIN product. The software has received high-level exposure, and Army-wide Hazardous Chemical committee members are scheduled to meet and discuss this program within the next year. Although the system is not yet totally operational at this time, plans are being made to recommend this software for all installations as the Army-wide standard system.

## **SPECIAL TEST EQUIPMENT**

### **Use of Neural Network Technology for Non-destructive Testing**

Benet Laboratories Research Division is using neural network technology on non-destructive testing techniques that had not yielded results using traditional analysis. One testing technique uses eddy current impedance changes at metal surfaces to identify defects. Another technique uses spectral signature of pulsed ultrasound signals to identify different materials that are contaminated.

Previous attempts to use these techniques without the benefit of the neural network had been unsuccessful. The neural network system has allowed them to differentiate between cracks and slag which was not previously possible.

### **Metrology and Inspection Division**

The Metrology and Inspection Division at WVA performs support functions that contribute to quality control in production. The Division acquires, accepts, supplies, inventories, maintains, repairs and disposes of inspection equipment. It also manages the Arsenal inspection equipment calibration program and supply calibration service in accordance with MIL-Q-9858.

The Division's Laboratory Branch maintains a gage laboratory to provide inspection and calibration services. The laboratory includes a 4,000 square foot temperature

controlled facility with CMMs, with capabilities for angular measurements, roundness, surface analysis/profile, hardness, tensile/charpy testing, ultrasonic inspection, gear, thread and spline inspection.

In direct support of product design, the Division tests breech mechanisms and mortar assemblies produced by WVA. This effort involves gymnastication of breeches. Pressure simulation testing involves subjecting breeches and mortar tubes to extremely high pressure simulating the firing of a round. In-laboratory simulation is less expensive than field firing, and results are available immediately so production problems can be identified and acted on quickly.

The Division supports WVA and Benet Weapons Laboratory with a prototype-part inspection program. In 1991, it inspected 2,955 items. It also performs first article inspection on samples received from outside producers to determine conformance with contract requirements.

### **Gage Design**

The Quality and Instrumentation Engineering Branch at WVA develops final acceptance inspection, and test equipment and field gages in support of manufacturing production, field operations, and operations directorates. Effective gage design requires expertise in metrology, manufacturing methods, product functionality and knowledge of field use.

Special considerations in design of production gages encompass suitability for SPC and automation, including computer control and data acquisition. Production gaging considerations are used during product development to influence product and process specifications. This can help ensure that future production processes can be verified, and that product quality can be assessed at intermediate and final stages of manufacturing.

The main considerations in design of field inspection equipment – those used by soldiers – are ruggedness to suit environments for transportation and use; level of education and training of personnel; and providing readily interpretable information to allow soldiers to determine suitability of the guns for use in combat.

## **4.3 FACILITIES**

### **MODERNIZATION**

#### **Project REARM**

WVA addressed the problem of aging equipment and facilities and its inability to secure funding for acquisition and upgrades necessary to maintain its role as the cannon maker for the U.S. Army. Therefore, WVA performed evaluations internally and by a contractor to baseline conditions.

---

The assessment criteria included work flow, equipment utilization rates, spare part availability, technological obsolescence, age of equipment, maintenance factors, and versatility.

DoD Directive 4275.5 provides guidance that 5% of the capital equipment inventory value should be reinvested in replacement equipment on an annual basis. WVA research determined that for the five-year period of 1973-1978, funds available for reinvestment were limited to .5% of original investment. To reverse this trend, WVA developed a 12-year improvement program, REARM, to modernize and update their facilities and equipment.

A decision tree process was used to determine whether to rebuild, replace, or surplus WVA industrial plant equipment. At the same time, the assessment of its facilities and plant layout indicated that modernization was necessary to improve the product flow and increase efficiency. In retooling and modernization planning, emphasis was placed on computer numerical control, automated inspection, flexible manufacturing system/cells, quality of life, improved material handling, and process control.

WVA secured approval and funding to implement REARM. This program has added 305 new and 41 rebuilt machine tools, and added 186,000 square feet of modern plant facilities. The REARM program is almost complete with the final equipment due to be operational in 1993. The total impact of the REARM initiative has yet to be realized, but the results to date are impressive, including a 27% increase in productivity, a doubling of capacity and a one-third reduction in the number of industrial plant equipment to be maintained.

## Flexible Manufacturing Cell

Flexible manufacturing and automation will provide WVA with the capability to meet large increases in demand or a sudden need to shift product mix without a decrease in production efficiency. The Arsenal's manufacturing cells include a Horizontal Machining Cell, a Vertical Turning Cell, and a Vertical Boring Cell. These cells consist of three CNC Horizontal Machining Centers, two Vertical Turning Centers and four Vertical Boring Machines. Each cell is equipped with a mini-computer and rail guided material handling system. These cells have the capacity to perform work which would require 20 machines and an equivalent staff. The total investment in these cells is \$17.5 million. At the present time, all three cells are going through acceptance testing.

The Horizontal Machining Cell control system is a MicroVAX 3100 with tool and fixture management; automatic data collection; report generation; dynamic system display; and an interface with the DNC system. Its material

handling system is a rail-guided vehicle with two pallet transfer arms and a capacity of 12,000 pounds. It has 18 queue stands, and 34 pallets.

The Vertical Turning Cell control system is a MicroVAX 4000 with tool and fixture management; automatic data collection; report generation; dynamic system display; an interface with the DNC system. Its material handling system is a rail-guided vehicle with one transfer arm and a capacity of 6,000 pounds. It has 14 queue stands, 3 load stands and 12 pallets.

The Vertical Boring Cell control system is a MicroVAX 4000 with tool and fixture management; automatic data collection; report generation; dynamic system display; and an interface with the DNC system. Its material handling system is a rail-guided vehicle with one transfer arm and a capacity of 6,000 pounds. It has 18 queue stands, four load stands, and 15 pallets.

Parts manufactured in these cells are expected to be of higher quality compared to parts produced through conventional methods. Improved quality is expected to be attributed to the combining of manufacturing processes without retooling, probing capabilities, and continuous monitoring/feedback of the status of the machine tool. The net effect of cellular manufacturing is the increased efficiency of production operations.

These flexible manufacturing cells promise benefits in addition to producing high quality parts. These benefits include a more effective utilization of manufacturing floor space, reduction of WIP inventory, and prompt delivery of the product to the customer.

The versatility of these cells permits the production of a wide variety of cylindrical and prismatic work pieces to extremely close tolerances. In addition to production components, prototype parts are planned to be routinely processed through these cells. The flexible manufacturing cells represent one of WVA's answers to meet the customer's needs for high quality and quick delivery.

## **FACTORY IMPROVEMENTS**

### Advanced CIM Project

The Advanced CIM program at WVA began in 1990 as a compilation of various enabling manufacturing technologies. It has grown to be a multimillion dollar project with significant impacts to manufacturing, product quality, and production capability and capacity. A key objective throughout this program has been to adopt proven technological innovations which have lower implementation risks and higher success rates.

The following are some of the technologies targeted for improvements at WVA.

---

*Quick Change Setup* – Modular fixturing has been implemented as well as setup reduction training for 40 first-line supervisors. Additionally, a setup reduction team has been formed and video taping of setup operations has begun. Future plans include block cutting tools and power work holding.

*Modern Material Handling* – Efforts include an Automatic Storage/Retrieval System upgrade, centralizing a spare parts storage system, and development of a hazardous waste management system. Future planned efforts include Flexible Manufacturing System Material Handling, Gun Tube Storage Racks, power and free conveyor systems, and radio controlled cranes.

*Probing and Non-contact Gaging* – Current efforts include networking CMM machines, in-process control of honing, and installation of laser measurement on the rotary forge. Future work plans center on powder chamber gaging.

*In-Process and Adaptive Controls* – Efforts include development of real time SPC, Selas furnace upgrade (next generation controller), broach tool monitoring and turntable anti-vibration boring bar (servo motor to adjust cutting tool).

*Machine Monitoring and Diagnostics* – Efforts include vibration monitoring of machine tools and computerized maintenance management systems.

*Voice Recognition Systems* - Planned work includes voice input quality data and voice input inventory data.

*Tool Standardization* - Efforts include process review consolidation, standardization, and optimization.

*Non-conventional Machining Methods* - A tensile and charpy manufacturing cell has been established featuring an abrasive waterjet cutting system.

Future efforts will continue the emphasis on application of existing technology vice development of new technology.

## **4.4 MANAGEMENT**

### **MANUFACTURING STRATEGY**

#### **Program Management Tools**

New DoD regulations require WVA to produce a monthly Cost/Schedule Status Report on all Level 0 and Level I manufactured parts on the 120mm Mortar Program. To provide the required detailed status information to its customer and enable WVA to improve its competitive posture, the Information Management Directorate recently developed the following sales and costs reports for the 120mm

Mortar Program – costs associated with original set-up by cost area for all Level I assemblies; daily, weekly, and monthly summaries of labor charges; production material unit cost for Level I assemblies; production material cost investment value for Level I assemblies; and end-of-month WIP for each component.

This report system can be applied as a generic solution to any manufactured product. The reports have satisfied the DoD reporting requirements to its customers and has proven to be an effective management tool for production tracking and WIP investment value. The basic system will be used as a foundation for future requirements.

#### **Minimization of Waste Streams**

Watervliet Arsenal recently initiated a comprehensive HAZMIN program that addresses the \$3M annual disposal costs at the Arsenal. Projected cost savings of \$450K are anticipated for 1992, reaching a total of \$1M by 1996 and another \$500K by 2000. The program focuses on the disposal costs associated with alkaline corrosive liquids, acidic corrosive liquids, chromic acid, contaminated demolition materials, paint related materials, PCB items, industrial wastes, and treatment plant rinse waters and spills.

Driven by the forces of the Environmental Protection Agency, Department of the Army, and New York State to upgrade the environment and protect the future, as well as the increasing costs to dispose of hazardous waste materials, WVA initiated the HAZMIN Program. The mechanisms in the form of a Hazardous Waste Reduction Plan, an action committee, performance goals, and Arsenal-wide involvement down to the worker level are in place at WVA.

Almost 30 HAZMIN projects have been identified including treatment of chromium waste from the purification of hard chrome plating solutions; replacement of ethylene glycol with propylene glycol; and disposal of cleaning solutions from heat treatment and minor plating.

Supporting the HAZMIN program is an on-line database which stores some 4,000 data records of material transaction at the Arsenal. This system not only tracks the inventories of hazardous materials, it provides an efficient production of data and reports necessary for state and federal compliance, the Material Safety Data Sheets, and training activities.

### **DATA REQUIREMENTS**

#### **Customer Feedback**

WVA maintains the firing records history of all U.S. Army cannon, howitzers, and mortars. The safe service life depends upon the number of rounds fired and the type of

round, making the records vitally important to the lives of soldiers. The WVA receives 600 field inquiries and correction notifications annually. In 1991, 20,107 gun cards were processed.

WVA provides the coordination with worldwide Logistics Assistance representatives. It supports program and item manager initiatives in ammunition investigations, analysis of fielded assets, special projects, and data collection and analysis. They also support requirements development,

integrated test working groups, technical manual verification, and provide recommendations to the Ft. Knox Armor School.

WVA has a consolidated customer feedback program under development (Figure 4-1). The database will provide the information for customer inquiries, complaints, field failures/malfunctions, problems, comments, remaining life requests, and the proposed gun card questionnaire in a more timely manner than the current hard copy systems.

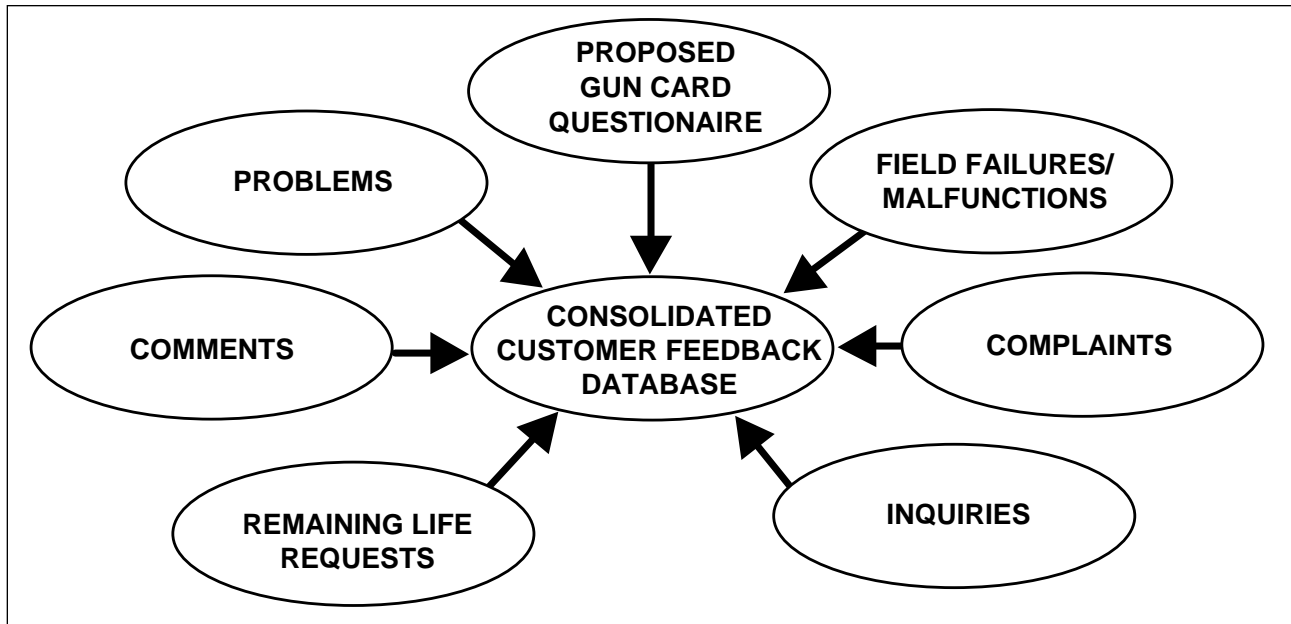

**FIGURE 4-1. CUSTOMER FEEDBACK SYSTEM**

# SECTION 5

## PROBLEM AREAS

---

### 5.1 DESIGN

#### DESIGN POLICY

##### Non-developmental Item Procurement

Benet Laboratories was tasked to develop a TDP for production of a 120mm mortar. The mortar was a non-developmental item purchased from a foreign source. The foreign TDP was adapted for American use by one of the U.S. contractors for the Army Project Manager. Benet then received the drawings and began procurement actions for the six prototypes.

The Army had already purchased 63 mortars from the foreign source to use for training. Benet was restricted from making any changes to the data packages that would affect spare parts for the foreign supplied mortars. They were also not allowed to procure any parts from foreign sources. Several of the parts were not available from domestic sources off the shelf; however, they could be supplied production quantities at a premium price for the special runs. Numerous discrepancies were later found in the drawings that affected the parts and assembly. Several of the parts previously procured were unusable and not returnable.

Lessons learned in this experience include that drawing conventions are dissimilar between U.S. and foreign companies; specifications for foreign parts are not readily available in the U.S., and the foreign source's philosophy of "fit at assembly" does not work.

### 5.2 MANAGEMENT

#### DATA REQUIREMENTS

##### DoD Accounting Requirements

The long-term future of government manufacturing facilities like WVA may be determined by the cost, pricing, and accounting practices they are obliged to follow. Five key areas are:

- **Depreciation** - The arsenal has invested in advanced/high technology manufacturing equipment in order to consistently produce high quality products. In an environment of price sensitive product lines constrained

by shrinking defense budgets, longer depreciation proposed periods provide a major pricing advantage. Proposed standard amortization schedules imposed across the Defense Manufacturing Network are not the answer. Significant local management flexibility must be allowed to manage depreciation expense versus capital equipment replacement requirements to accommodate price competitiveness and unique manufacturing environments.

- **Apportionment of Depreciation** - Much of the capital investment made by Watervliet Arsenal was for surge capacity. As the nation's only cannon producer, WVA has a mobilization mission requirement to maintain a surge capacity. In a non-surge production environment, a smaller product base absorbs an accentuated depreciation expense allocation as capital assets remain in place available for use yet are not being consumed at maximum capacity. This scenario drives the price of a constrained product line up and is again detrimental to competitive posture. Central DoD funding for underutilized capacity has been the proposed solution for years, and it is a viable one. Watervliet Arsenal has made extensive efforts to identify and layaway unutilized assets in place. This has only had a minor effect on reducing depreciation expense since the problem is *underutilization* of assets: not *unutilization*.
- **Pricing** - Watervliet Arsenal is required to honor fixed price contracts for DoD customers years after original cost estimates are made. Contracts for most commercial and foreign customers are required to be performed on a cost reimbursable basis. Recognizing that the requirement for commercial and foreign customers to pay full cost on contracts is driven by statute, DoD must recognize that this pricing strategy is noncompetitive and pursue legislation to allow price stabilization for commercial and foreign customers.
- **Local Operating Discretion** - Watervliet Arsenal is not allowed to finance material inventory in advance of appropriations. This restriction has its basis in appropriations law and accentuates the time period to complete customer orders. DoD should consider a revision to statutes which would allow inventories in

---

advance of customer orders. A comprehensive internal control program would be required to ensure compliance.

- **Labor Based Accounting** - DoD must become more flexible in allowing government manufacturing facilities to pursue established accounting principles which would accommodate high technology manufacturing environments that are increasingly machine intensive versus labor intensive. This would improve the precision of product costs and assure equitable distribution of indirect costs. However, local production planning and control activities are the requirements drivers of

the accounting system, and they must study and document any revised operational and planning processes which accommodate current manufacturing environments. DoD must get out of the business of mandating managerial accounting (cost accounting) methodology without knowledge of unique installation manufacturing plans and processes.

As factories like WVA improve the precision and predictability of its products, its ability to determine product costs is moving in the opposite direction. This is neither a formula for success nor a problem the Arsenal can solve by itself.

# APPENDIX A

## ***TABLE OF ACRONYMS***

---

<b>Acronym</b>	<b>Definition</b>
ATF	Acceptance Test Facility
AMS	Acquisition Monitoring System
AOD	Arsenal Operations Directorate
ESIP	Engineering Support in Production
FCIM	Flexible Computer-Integrated Manufacturing
GTIS	Gun Tube Inspection Station
HAZMIN	Hazardous Waste Minimization
HC	High Contraction
IMPACT	Improved Maintenance Performance and Control Thrust
LC	Low Contraction
REARM	Renovation of Armament Manufacturing
TDP	Technical Data Package

---

# APPENDIX B

## ***BMP SURVEY TEAM***

---

<b>Team Member</b>	<b>Agency</b>	<b>Role</b>
<b>Bob Jenkins</b> (703) 746-3553	<b>NAVSEA</b> Washington, DC	<b>Team Chairman</b>
<b>Amy Scanlan</b> (206) 679-9008	<b>BMP Representative</b> Oak Harbor, WA	<b>Technical Writer</b>
<b>Larry Robertson</b> (812) 854-5336	<b>Crane Division</b> <b>Naval Surface Warfare Center</b> Crane, IN	<b>Team Leader</b> Design/Test
<b>Will Best</b> (703) 746-3500	<b>NAVSEA</b> Washington, DC	
<b>Kevin Lynaugh</b> (301) 602-3822	<b>Naval Surface Warfare Center</b> <b>Carderock Division</b> Bethesda, MD	
<b>Bill Rippey</b> (301) 975-3417	<b>Automated Manufacturing</b> <b>Research Facility</b> Bethesda, MD	
<b>Jack Tamargo</b> (707) 557-4985	<b>Mare Island Naval Shipyard</b> Vallejo, CA	<b>Team Leader</b> Production/Facilities
<b>Caroline Poage</b> (707) 557-4985	<b>Mare Island Naval Shipyard</b> Vallejo, CA	
<b>Cynthia Krist</b> (309) 782-7861	<b>Rock Island Arsenal</b> Rock Island, IL	
<b>Denny Crouch</b> (502) 364-6790	<b>Naval Ordnance Station</b> Louisville, KY	
<b>Rick Purcell</b> (703) 271-9055	<b>BMP Representative</b> Washington, DC	<b>Team Leader</b> Management/Logistics
<b>Larry Halbig</b> (317) 353-3838	<b>Aircraft Division - Indianapolis</b> <b>Naval Air Warfare Center</b> Indianapolis, IN	
<b>CDR Mark Cooper</b> (805) 756-2571	<b>NAVSEA</b> Washington, DC	
<b>Tip Parker</b> (202) 377-0825	<b>Department of Commerce</b> Washington, DC	

# APPENDIX C

## **NAVY CENTERS OF EXCELLENCE**

---

### **Automated Manufacturing Research Facility** (301) 975-3414

The Automated Manufacturing Research Facility (AMRF) – a National Center of Excellence – is a research test bed at the National Institute of Standards and Technology located in Gaithersburg, Maryland. The AMRF produces technical results and transfers them to the Navy and industry to solve problems of automated manufacturing. The AMRF supports the technical work required for developing industry standards for automated manufacturing. It is a common ground where industry, academia, and government work together to address pressing national needs for increased quality, greater flexibility, reduced costs, and shorter manufacturing cycle times. These needs drive the adoption of new computer-integrated manufacturing technology in both civilian and defense sectors. The AMRF is meeting the challenge of integrating these technologies into practical, working manufacturing systems.

### **Electronics Manufacturing Productivity Facility** (317) 226-5607

Located in Indianapolis, Indiana, the Electronics Manufacturing Productivity Facility (EMPF) is a National Center of Excellence established to advance state-of-the-art electronics and to increase productivity in electronics manufacturing. The EMPF works with industry, academia, and government to identify, develop, transfer, and implement innovative electronics manufacturing technologies, processes, and practices. The EMPF conducts applied research, development, and proof-of-concept electronics manufacturing and design technologies, processes, and practices. It also seeks to improve education and training curricula, instruction, and necessary delivery methods. In addition, the EMPF is striving to identify, implement, and promote new electronics manufacturing technologies, pro-

cesses, materials, and practices that will eliminate or reduce damage to the environment.

### **National Center for Excellence in Metalworking Technology**

(814) 269-2420

The National Center for Excellence in Metalworking Technology (NCEMT) is located in Johnstown, Pennsylvania and operated by Concurrent Technologies Corporation (CTC), a subsidiary of the University of Pittsburgh Trust. In support of the NCEMT mission, CTC's primary focus includes working with government and industry to develop improved manufacturing technologies including advanced methods, materials, and processes, and transferring those technologies into industrial applications. CTC maintains capabilities in discrete part design, computerized process analysis and modeling, environmentally compliant manufacturing processes, and the application of advanced information science technologies to product and process integration.

### **Center of Excellence for Composites Manufacturing Technology**

(414) 947-8900

The Center of Excellence for Composites Manufacturing Technology (CECMT), a national resource, is located in Kenosha, Wisconsin. Established as a cooperative effort between government and industry to develop and disseminate this technology, CECMT ensures that robust processes and products using new composites are available to manufacturers. CECMT is operated by the GreatLakes Composites Consortium. It represents a collaborative approach to provide effective advanced composites technology that can be introduced into industrial processes in a timely manner. Fostering manufacturing capabilities for composites manufacturing will enable the U.S. to achieve worldwide prominence in this critical technology.

# APPENDIX D

## ***PREVIOUSLY COMPLETED SURVEYS***

---

BMP surveys have been conducted at the companies listed below. Copies of survey reports for any of these companies may be obtained by contacting:

Best Manufacturing Practices Program  
Office of the Chief of Naval Research  
Office of Advanced Technology (341)  
Attn: Mr. Ernie Renner  
Arlington, VA 22217-5660  
Telephone: (703) 696-8482

### **COMPANIES SURVEYED**

Litton  
Guidance & Control Systems Division  
Woodland Hills, CA  
October 1985 and February 1991

Texas Instruments  
Defense Systems & Electronics Group  
Lewisville, TX  
May 1986 and November 1991

Harris Corporation  
Government Support Systems Division  
Syosset, NY  
September 1986

Control Data Corporation  
(Computing Devices International)  
Government Systems Division  
Minneapolis, MN  
December 1986

ITT  
Avionics Division  
Clifton, NJ  
September 1987

UNISYS  
Computer Systems Division  
(Paramax)  
St. Paul, MN  
November 1987

General Dynamics  
Fort Worth Division  
Fort Worth, TX  
May 1988

Honeywell, Incorporated  
Undersea Systems Division  
(Alliant Tech Systems, Inc.)  
Hopkins, MN  
January 1986

General Dynamics  
Pomona Division  
Pomona, CA  
August 1986

IBM Corporation  
Federal Systems Division  
Owego, NY  
October 1986

Hughes Aircraft Company  
Radar Systems Group  
Los Angeles, CA  
January 1987

Rockwell International Corporation  
Collins Defense Communications  
Cedar Rapids, IA  
October 1987

Motorola  
Government Electronics Group  
Scottsdale, AZ  
March 1988

Texas Instruments  
Defense Systems & Electronics Group  
Dallas, TX  
June 1988

---

Hughes Aircraft Company  
Missile Systems Group  
Tucson, AZ  
August 1988

Litton  
Data Systems Division  
Van Nuys, CA  
October 1988

McDonnell-Douglas Corporation  
McDonnell Aircraft Company  
St. Louis, MO  
January 1989

Litton  
Applied Technology Division  
San Jose, CA  
April 1989

Standard Industries  
La Mirada, CA  
June 1989

Teledyne Industries Incorporated  
Electronics Division  
Newbury Park, CA  
July 1989

Lockheed Corporation  
Missile Systems Division  
Sunnyvale, CA  
August 1989

General Electric  
Naval & Drive Turbine Systems  
Fitchburg, MA  
October 1989

TRICOR Systems, Incorporated  
Elgin, IL  
November 1989

TRW  
Military Electronics and Avionics Division  
San Diego, CA  
March 1990

Boeing Aerospace & Electronics  
Corinth, TX  
May 1990

Textron Lycoming  
Stratford, CT  
November 1990

Bell Helicopter  
Textron, Inc.  
Fort Worth, TX  
October 1988

GTE  
C<sup>3</sup> Systems Sector  
Needham Heights, MA  
November 1988

Northrop Corporation  
Aircraft Division  
Hawthorne, CA  
March 1989

Litton  
Amecom Division  
College Park, MD  
June 1989

Engineered Circuit Research, Incorporated  
Milpitas, CA  
July 1989

Lockheed Aeronautical Systems Company-Georgia  
Marietta, GA  
August 1989

Westinghouse  
Electronic Systems Group  
Baltimore, MD  
September 1989

Rockwell International Corporation  
Autonetics Electronics Systems  
Anaheim, CA  
November 1989

Hughes Aircraft Company  
Ground Systems Group  
Fullerton, CA  
January 1990

MechTronics of Arizona, Inc.  
Phoenix, AZ  
April 1990

Technology Matrix Consortium  
Traverse City, MI  
August 1990

Norden Systems, Inc.  
Norwalk, CT  
May 1991

---

Naval Avionics Center  
Indianapolis, IN  
June 1991

Kurt Manufacturing Co.  
Minneapolis, MN  
July 1991

Raytheon Missile Systems Division  
Andover, MA  
August 1991

Tandem Computers  
Cupertino, CA  
January 1992

Conax Florida Corporation  
St. Petersburg, FL  
May 1992

Hewlett-Packard  
Palo Alto Fabrication Center  
Palo Alto, CA  
June 1992

United Electric Controls  
Watertown, MA  
June 1991

MagneTek Defense Systems  
Anaheim, CA  
August 1991

AT&T Federal Systems Advanced Technologies  
and AT&T Bell Laboratories  
Greensboro, NC and Whippany, NJ  
September 1991

Charleston Naval Shipyard  
Charleston, SC  
April 1992

Texas Instruments  
Semiconductor Group  
Military Products  
Midland, TX  
June 1992

Information gathered from all BMP surveys is included in the Best Manufacturing Practices Network (BMPNET). Additionally, calendar of events and other relevant information are included on BMPNET. All inquiries regarding the BMPNET may be directed to:

BMP Director  
Office of the Chief of Naval Research  
Office of Advanced Technology (341)  
800 North Quincy Street  
Arlington, VA 22217-5660  
Telephone: (703) 696-8482  
FAX: 703) 696-8480

---