

# **BMP**

*REPORT OF SURVEY CONDUCTED AT*  
**SANDIA NATIONAL LABORATORIES**

**ALBUQUERQUE, NM  
LIVERMORE, CA**

*MAY 1995*

## ***Best Manufacturing Practices***



**CENTER OF EXCELLENCE FOR BEST MANUFACTURING PRACTICES**

**College Park, Maryland**



## “CRITICAL PATH TEMPLATES FOR TRANSITION FROM DEVELOPMENT TO PRODUCTION”

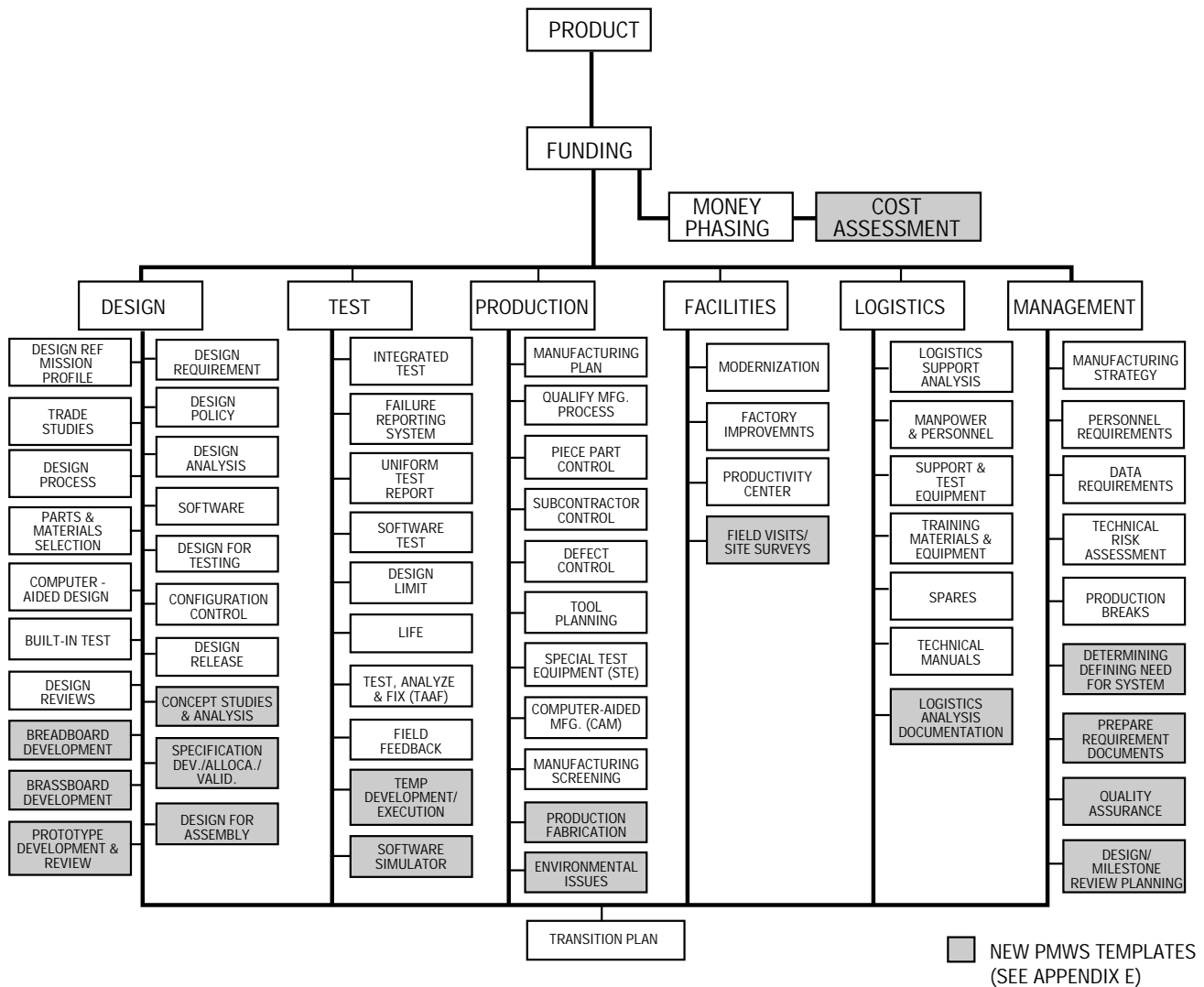

# P R E F A C E

---



During the week of January 23, 1995, a Best Manufacturing Practices (BMP) survey was conducted at Sandia National Laboratories (SNL) located in Albuquerque, New Mexico and Livermore, California. The multiprogram SNL, a Department of Energy national effort, maintains sites in New Mexico and California with test facilities in Nevada and Hawaii. They are operated by the Sandia Corporation, a wholly owned subsidiary of Martin Marietta, and employ over 8500 personnel with an annual budget of more than \$1.4 billion.

Sandia's research and engineering efforts are solidly based on a matrix of core competencies that have produced technological advances based on 40 years of research and development in nuclear weapons, energy, and environmental efforts. Systems such as EcoSys™ and the Multi-Dimensional User-Oriented Synthetic Environment are examples of technology with practical application, and represent SNL's effort to enhance America's national defense, global competitiveness, and quality of life.

BMP surveys are conducted to identify best practices in one of the critical path templates of the Department of Defense (DOD) 4245.7-M, "Transition from Development to Production." This document provides the basis for BMP surveys that concentrate on areas of design, test, production, facilities, logistics, and management. Practices in these areas and other areas of interest are presented, discussed, reviewed, and documented by a team of government engineers who are invited by the company to evaluate the company's policies, practices, and strategies. Only non-proprietary practices selected by the company are reviewed. In addition to the company's best practices, the BMP survey team also reviews potential industry-wide problems that can be referred to one of the Navy's Manufacturing Technology Centers of Excellence. The results of the BMP surveys are entered into a database for dissemination through a central computer network. The actual exchange of detailed data is between companies at their discretion.

The Best Manufacturing Practices program is committed to strengthening the U.S. industrial base. Improving the use of existing technology, promoting the introduction of enhanced technologies, and providing a non-competitive means to address common problems are critical elements in achieving that goal. This report on Sandia National Laboratories will provide you with information you can use for benchmarking and is part of the national technology transfer effort to enhance the competitiveness of the U.S. industrial base.

# CONTENTS

---

---

## **1. EXECUTIVE / REPORT SUMMARY**

<b>1.1 BACKGROUND</b> .....	1
<b>1.2 BEST PRACTICES</b> .....	2
<b>1.3 INFORMATION ITEMS</b> .....	5
<b>1.4 ACTIVITY POINT OF CONTACT</b> .....	8

---

## **2. BEST PRACTICES**

### **2.1 DESIGN**

#### **DESIGN REQUIREMENTS**

Preferred Design Processes and Practices for Flight Hardware .....	9
Department of Energy/Department of Defense Environmental Data Bank ..	9
Model-Based Design and Virtual Prototyping .....	9

#### **DESIGN ANALYSIS**

Multi-Dimensional User-Oriented Synthetic Environment .....	10
Automated Mesh Generation for Engineering Analysis .....	11
Reliability Analysis and Modeling Program .....	11

#### **DESIGN PROCESS**

Advanced Manufacturing Software ToolKit Environment .....	12
Structural Dynamics and Vibrational Control .....	12
Vector Automatic Network Analyzers Certification Approaches .....	13
Parent-Child Design Paradigm .....	13

#### **SOFTWARE DESIGN**

Sandia Preferred Processes for Software Development.....	14
--	----

#### **COMPUTER-AIDED DESIGN**

Interactive Collaborative Environments .....	15
Nuclear Safety Information Center .....	16

#### **CONFIGURATION CONTROL**

Pentagon-S: Safety Critical Piece Part and Defect Control .....	16
---	----

#### **PROTOTYPE DEVELOPMENT AND REVIEW**

Integrating Rapid Prototyping and Computer Simulation into Investment Casting .....	16
Prototype Electronics Facility .....	17

# CONTENTS (Continued)

---

## **2.2 TEST**

### **INTEGRATED TEST**

Quiescent Power Supply Current Testing .....	18
Microelectronics Reliability Benchmarking Facility .....	19

### **FAILURE REPORTING SYSTEM**

Integrated Circuit Failure Analysis Expert System .....	19
---	----

## **2.3 PRODUCTION**

### **MANUFACTURING PLAN**

Agile Manufacturing Facility for Integrated Circuits .....	20
--	----

### **QUALIFY MANUFACTURING PROCESS**

Machine and Process Characterization .....	21
--	----

### **SUBCONTRACTOR CONTROL**

Manufacturing Liaison Supplier Performance System .....	21
---	----

### **SPECIAL TEST EQUIPMENT**

Techniques for Aging Aircraft Inspection .....	22
--	----

### **PIECE PART CONTROL**

Hierarchical Qualification of Electrical Components .....	22
---	----

### **ENVIRONMENTAL ISSUES**

Environment, Safety, and Health Regulatory Compliance	
Support for Suppliers .....	23
Low-Residue, No-Clean Soldering Process .....	23

## **2.4 FACILITIES**

### **MODERNIZATION**

Concurrent Engineering Communications .....	24
Department of Energy Primary Standards Facility .....	24

### **PRODUCTIVITY CENTER**

Facilities Accelerated System Team .....	25
--	----

### **FIELD VISIT / SITE SURVEYS**

Technical Surveys for Standards Laboratories .....	25
--	----

## **2.5 LOGISTICS**

### **SUPPORT AND TEST EQUIPMENT**

Non-destructive Evaluation Capabilities for Process Monitoring .....	25
--	----

### **TRAINING MATERIALS AND EQUIPMENT**

Instructional Video .....	26
---------------------------	----

# CONTENTS (Continued)

---

## **2.6 MANAGEMENT**

### **MANUFACTURING STRATEGY**

Small Business Initiative .....	26
Small Business Programs .....	27
Quick Pay Invoiceless Payment Processing .....	28
Just-In-Time Procurement System .....	28

### **PERSONNEL REQUIREMENTS**

Total Life Concept Health Promotion Program .....	28
---	----

### **DATA REQUIREMENTS**

Integrated Records System for High Reliability Production .....	29
Nuclear Waste Management Center Computer Support Tracking System .....	29

### **MANUFACTURING STRATEGY**

Application of Quality Function Deployment to Battery Design .....	30
--	----

### **QUALITY ASSURANCE**

Evaluation of Low-Noise Seismometers .....	31
--	----

### **COMPUTER-AIDED DESIGN**

Advanced Manufacturing Technology Network .....	31
---	----

---

## **3. INFORMATION**

### **3.1 FUNDING**

#### **COST ASSESSMENT**

Controlling Manufacturing Costs Using Activity-Based Costing .....	33
--	----

### **3.2 DESIGN**

#### **DESIGN POLICY**

High Consequence System Surety .....	33
--------------------------------------	----

#### **DESIGN PROCESS**

Electronic Design Automation Process .....	33
Laydown Weapons Parachutes .....	34
A-PRIMED Process Improvements .....	34
Laser Spot Weld Representation .....	34
Concurrent Engineering in the Recode System and Thermal Batteries .....	35
Control Device Database/Measurement Software .....	35
Utility Battery Storage Systems Program .....	36
Engineering Analysis Contribution to Agile Manufacturing .....	36
Engineering Simulation for Model Based Design .....	36
Fuzzy/Probabilistic Hybrid Analysis .....	36
Integrated Assembly Planning .....	37

# CONTENTS (Continued)

---

## **3.1 DESIGN PROCESS (Continued)**

### **PARTS AND MATERIALS SELECTION**

Microporous Polyimide Films for Reduced Dielectric Applications ..... 37

### **PARTS AND MATERIALS SELECTION**

Agile Cable Acquisition and Production System ..... 38

### **SOFTWARE DESIGN**

Software Process Improvement ..... 38

Computer-Aided Molecular Design - Fullerenes ..... 39

### **COMPUTER-AIDED DESIGN**

Electrical System Simulation and Analysis ..... 40

### **DESIGN REVIEWS**

Virtual Collocation of Product Realization Teams ..... 40

### **CONCEPT STUDIES AND ANALYSIS**

Integrated Development Environment and Assistant Program ..... 41

Optical Studies of Diesel Fuel Combustion ..... 41

### **PROTOTYPE DEVELOPMENT AND REVIEW**

Virtual Company ..... 43

## **3.2 TEST**

### **INTEGRATED TEST**

Evaluation of High Resolution Digitizers ..... 43

### **SOFTWARE TEST**

Software Unit Testing ..... 44

## **3.3 PRODUCTION**

### **QUALIFY MANUFACTURING PROCESS**

Process Characterization Methodology ..... 44

### **DEFECT CONTROL**

Cable Tester ..... 45

Low Volume Statistical Process Control ..... 45

### **TOOL PLANNING**

Solids Model/CNC Programming ..... 45

### **COMPUTER-AIDED MANUFACTURING**

An Expert System to Support Green Design and Manufacturing ..... 46

A-PRIMED Robotic Workcell ..... 46

Engraving Complex Layouts Directly from CAD Files ..... 47

Automated Cleaning of Electronic Components ..... 47

Automated Assembly Planning ..... 48

### **SUBCONTRACTOR CONTROL**

Two-Phase Supplier Selection ..... 48

# CONTENTS (Continued)

---

## **3.4 FACILITIES**

### **MODERNIZATION**

Shielded Plasma Cleaning for Package Assembly ..... 48

Manufacturing Prototyping Facility ..... 49

### **FACTORY IMPROVEMENTS**

Preventive Maintenance ..... 50

Sandia Voice Information System ..... 50

Nuclear Waste Management Program Administrative  
Information Management System ..... 51

### **FIELD VISIT/SITE SURVEYS**

Benchmarking for Waste Minimization Project ..... 51

## **3.5 LOGISTICS**

### **TECHNICAL MANUALS**

Computer-Aided Acquisition and Logistics Support  
Operational Network ..... 52

## **3.6 MANAGEMENT**

### **MANUFACTURING STRATEGY**

Electrical Seamless Manufacturing Team ..... 52

Technologies Enabling Agile Manufacturing ..... 52

### **PERSONNEL REQUIREMENTS**

Benefits Services ..... 53

Processes Developed for Test and Evaluation ..... 54

### **DETERMINE/DEFINE NEED FOR SYSTEM**

Systems Engineering ..... 56

### **QUALITY ASSURANCE**

President's Quality Award ..... 56

High Voltage Pulse Generator and Calibration Equipment ..... 56

Transitioning Existing Weapon Designs into Manufacture ..... 57

Qualification of Weapon Processes and Product ..... 57

Sandia Volt Map Program ..... 58

---

**APPENDIX A - TABLE OF ACRONYMS** ..... A-1

**APPENDIX B - BMP SURVEY TEAM** ..... B-1

**APPENDIX C - PROGRAM MANAGER'S WORKSTATION** ..... C-1

**APPENDIX D - NAVY CENTERS OF EXCELLENCE** ..... D-1

**APPENDIX E - NEW BEST MANUFACTURING PRACTICES PROGRAM TEMPLATES** ..... E-1

**APPENDIX F - COMPLETED SURVEYS** ..... F-1

---



# FIGURES

---

## FIGURES

2-1	Modular Adaptable Controller .....	10
2-2	Maze Wheel .....	11
2-3	Basic Layout for Analyzing Chatter in the Milling Process .....	12
2-4	Design Constraints Parameter Space .....	13
2-5	Design Process Tasks .....	14
2-6	CLERVER Software .....	15
2-7	Component Footprint Etched Orientation Features .....	17
2-8	Keating-Meyer $I_{DDQ}$ Circuit .....	18
2-9	$I_{DDQ}$ Testing .....	18
2-10	Relative Electromigration Lifetimes of ICs by Manufacturers .....	19
2-11	ICFAX User Display .....	20
2-12	Socioeconomic Activity .....	27
2-13	Program Evaluation .....	29
2-14	The QFD Approach .....	30
2-15	FACT Shotgun Borehole .....	31
2-16	Advanced Manufacturing Technologies Network .....	31
3-1	Schematic of Porous Film Formation .....	37
3-2	Rough Quote Cable Harness Drawing .....	38
3-3	Software Process Improvement Method .....	39
3-4	Diagram of a Fullerene .....	40
3-5	TIE-IN to IDEA .....	41
3-6	Diesel Engine Combustion (Old vs. New) .....	42
3-7	Evolution of Diesel Engine Emission Control .....	42
3-8	Virtual Company Interdependence .....	43
3-9	Software Unit Testing .....	44
3-10	The EcoSys™ Framework Components .....	46
3-11	Simulation of Robotic Spray Workcell .....	47
3-12	Downstream or Shielded Plasma Process and Direct Plasma Process ....	48
3-13	Sandia/California Manufacturing Prototyping Facility .....	49
3-14	Benchmarking Process .....	51
3-15	TEAM Concept .....	52
3-16	SNL Health Care Cost Vs. Other Employers .....	53
3-17	Process Flow Diagram .....	55
3-18	Concurrent Qualification .....	57

# T A B L E S

---

## TABLES

Table 2-1	Technology Transfer to Small Business .....	26
Table 2-2	FY94 Awarded Contracts and Commercial Percentages .....	27

# SECTION 1

## **EXECUTIVE / REPORT SUMMARY**

---

### **1.1 BACKGROUND**

The Sandia National Laboratories (SNL), a Department of Energy (DOE) national effort maintains sites in New Mexico and California with test facilities in Nevada and Hawaii. Headquartered in Albuquerque, NM and operated by the Sandia Corporation, a wholly-owned subsidiary of Martin Marietta, SNL employs over 8500 personnel and has an annual budget of more than \$1.4 billion. The laboratories have facilities for manufacturing process development, environmental testing, renewable energy, radiation research, combustion research, computing, and microelectronics research and production.

Sandia's research-based engineering efforts are solidly based on a matrix of core competencies. Comprised of two critical elements, research foundations and integrated capabilities, Sandia's core competencies have been developed and advanced by 40 years of research and development in nuclear weapons, energy, environmental, and work for other government agencies. These core competencies are critical to SNL's long term success and constitute their singular capabilities in the national laboratory field. Engineered processes and materials, computational and information sciences, microelectronics and photonics, and engineering sciences comprise Sandia's four major research foundations. These are complemented by and rely on the laboratories' integrated capabilities of Advanced Manufacturing Technology, Advanced Information Technology, Electronics, and Pulsed-Power.

Originally tasked with nuclear weapon development, SNL has expanded their mission beyond that of researching and developing programs for solutions to military security, energy security, environmental integrity, and work for other government agencies. SNL now also maintains a goal to team with industry in programs to include advanced manufacturing technologies, improved transportation, cost-effective health care, and information/computation science and technology. These new responsibilities are in response to the changing global environment and Sandia's endeavor to share technology to enhance America's global competitiveness and the national quality of life.

As one of the premier laboratories in the nation, Sandia offers industry and government a rich research and development resource. Sandians have researched and assiduously recorded information on complete process life cycles – information which industry needs. From years of experience in scientific areas, Sandia has also examined and developed

numerous related technological concepts which have practical applications in the industrial arena. For example, the design-for-environment system EcoSys™ can provide designers and process engineers with perspectives on the relative environmental impact between alternate designs. This information system taps into detailed life cycle, product, process, and material data that is critical to the analysis. Another example is Sandia's work in low volume statistical process control – a topic of vital interest to many manufacturers who are engaged in small quantity production or apply agile manufacturing techniques. Theoretical statistical research with limited production, coupled with integrating new and traditional SPC methods with adaptive filters, are providing enhanced tools for low volume process controls. SNL's research and development in modeling and simulation projects also provide excellent examples of technology applicability in the commercial world. The SNL-developed Multi-Dimensional User-Oriented Synthetic Environment is a virtual environment to provide users with an enhanced capability to examine, question, and understand relationships in complex information space. This system simplifies development of interactive graphical models and software, and creates a user-controlled environment to amplify the speed of human perception of that information. Manufacturing design and assembly analysis, operation of a multichip module, data analysis of seismic information, medical imaging, and dynamic simulation of explosive welding are just a few uses to which the Multi-Dimensional User-Oriented Synthetic Environment has already been applied.

Much of Sandia's work—as with several other government institutions—has been conducted behind required walls of security, and the shift to outreach programs has been a challenging one. However, Sandia continues to share lessons learned through hundreds of Cooperative Research and Development Agreements (CRADAs) and industry-government technology transfer efforts. One such project is the Technologies Enabling Agile Manufacturing group through which SNL and other DOE facilities, together with agencies such as the National Institute of Standards and Technology, Advanced Research Projects Agency, National Science Foundation, Agile Manufacturing Enterprise Forum, and the Society of Manufacturing Engineers, disseminate integrated design-to-manufacture tools and identify processes for streamlined and cost effective product development.

Sandia National Laboratories are staffed with personnel who are innovative, independent-thinking, motivated, and

represent a critical element of this national resource. This high level of expertise is as much a strength of SNL as the transferable technology. This combination of personnel, research and development proficiency, and technical capabilities makes Sandia a vital element in maintaining the United States' energy security as well as its environmental integrity and global economic competitive position.

This survey was supported by the United States Department of Energy under Contract DE-AC04-94AL85000.

## 1.2 BEST PRACTICES

The following best practices were identified at SNL.

Items	Page
<b>Preferred Design Processes and Practices for Flight Hardware</b>	<b>9</b>
The Advanced Digital and Power Subsystems Department of Sandia National Laboratories developed two documents to provide standardization of processes and practices in space-based electronic payload design.	
<b>Department of Energy/Department of Defense Environmental Data Bank</b>	<b>9</b>
SNL's Environments Engineering Group maintains the Department of Energy/Department of Defense Environmental Data Bank that contains information on identification and quantification of environments the weapons are expected to withstand.	
<b>Model-Based Design and Virtual Prototyping</b>	<b>9</b>
SNL has developed a Model Based-Design team to provide engineering personnel with the capability to design products and develop or improve processes using computer-generated virtual prototypes.	
<b>Multi-Dimensional User-Oriented Synthetic Environment</b>	<b>10</b>
The SNL-developed Multi-Dimensional User-Oriented Synthetic Environment is a leading edge virtual environment which demonstrates new approaches for interacting with computer-based information.	

Item	Page
<b>Automated Mesh Generation for Engineering Analysis</b>	<b>11</b>
SNL successfully applies mapped meshing algorithms for finite element analysis. These meshes are used to analyze the effects of externally applied loading on the component.	
<b>Reliability Analysis and Modeling Programs</b>	<b>11</b>
SNL developed a PC-based Reliability Analysis and Modeling Program to integrate data management, model development, model analysis, and graphic output.	
<b>Advanced Manufacturing Software ToolKit Environment</b>	<b>12</b>
SNL has developed an Advanced Manufacturing Software ToolKit Environment for the Fast Casting Process consortium of investment casting companies with potential for application in many manufacturing industries.	
<b>Structural Dynamics and Vibrational Control</b>	<b>12</b>
SNL performs computational and experimental analyses through computational structural dynamics and optimization, structural system identification, vibration/chatter control, and smart structures and materials.	
<b>Vector Automatic Network Analyzers</b>	<b>13</b>
The Primary Standards Laboratory has developed a process for the certification of microwave Vector Automatic Network Analyzers.	
<b>Parent-Child Design Paradigm</b>	<b>13</b>
The Sandia National Laboratories' Agile Product Realization of Innovative ElectroMechanical Devices Project has initiated a new design "parent-child" program where the "parent" refers to a class of products and "child" to an instance within the class.	
<b>Sandia Preferred Processes for Software Development</b>	<b>14</b>
SNL established preferred processes for software development to satisfy internal standardization, external standards, and customer requirements.	

<b>Item</b>	<b>Page</b>	<b>Item</b>	<b>Page</b>
<b>Interactive Collaborative Environments</b>	<b>15</b>	<b>Agile Manufacturing Facility for Integrated Circuits</b>	<b>20</b>
Computer scientists at SNL have developed a concurrent engineering tool to accommodate project team members physically isolated from one another to simultaneously work on the same drawings.		SNL Microelectronics Development Laboratory provides a model of agility, reconfigurability, and robustness in its integrated circuits fabrication cleanroom facility.	
<b>Nuclear Safety Information Center</b>	<b>16</b>	<b>Machine and Process Characterization</b>	<b>21</b>
A centralized document management system called the Nuclear Safety Information Center was created to achieve rapid retrieval of existing documents and create a specific central repository.		Sandia applies machine and process characterization to define and qualify a process window, or parameter space allowing the labs to quickly produce a product in an agile environment.	
<b>Pentagon-S: Safety Critical Piece Part and Defect Control</b>	<b>16</b>	<b>Manufacturing Liaison Supplier Performance System</b>	<b>21</b>
Sandia's Systems Surety Engineering Department introduced a new centralized Pentagon-S process to define safety controls for high-risk, high-consequence products and processes.		SNL established the Manufacturing Liaison Department to provide technical support for designers and buyers. As this department evolved, a supplier database was established which has enabled SNL to identify over 3000 contractors' capabilities and performance.	
<b>Integrating Rapid Prototyping and Computer Simulation into Investment Casting</b>	<b>16</b>	<b>Techniques for Aging Aircraft Inspection</b>	<b>22</b>
SNL's Integrating Rapid Prototyping Laboratory uses a commercial stereolithography system and selective laser sintering to quickly respond to the needs of its customers.		The Federal Aviation Administration created an Aging Aircraft Non-destructive Inspection Validation Center at Sandia to address aerospace industry needs for its aging civilian fleet.	
<b>Prototype Electronics Facility</b>	<b>17</b>	<b>Hierarchical Qualification of Electrical Components</b>	<b>22</b>
SNL developed an integrated approach to prototype development at its Electronic Prototype Laboratory.		SNL has developed a new component selection and evaluation plan to produce a telemetry processor of the highest quality.	
<b>Quiescent Power Supply Current Testing</b>	<b>18</b>	<b>Environment, Safety, and Health Regulatory Compliance Support for Suppliers</b>	<b>23</b>
Sandia National Laboratories and the University of New Mexico have developed a test circuit to indirectly measure quiescent power supply current called the Keating-Meyer $I_{DDQ}$ Circuit.		Sandia has developed a database/knowledge-based system to perform environment, safety, and health regulatory compliance assessments of manufacturing processes.	
<b>Microelectronics Reliability Benchmarking Facility</b>	<b>19</b>	<b>Low-Residue, No-Clean Soldering Process Evaluation</b>	<b>23</b>
The SNL Microelectronics Reliability Benchmarking Facility independently tests commercial manufacturers' integrated circuits to benchmark reliability.		Sandia National Laboratories entered into a joint program with Motorola's Government Electronics Group and Los Alamos National Laboratory to evaluate a no-clean soldering process acceptable for Department of Defense applications. The no-clean process studied incorporates a dilute adipic acid flux which is ultrasonically sprayed on the PWBs to remove oxidized materials before soldering.	
<b>Integrated Circuit Failure Analysis Expert System</b>	<b>19</b>		
Failure Analysis engineers at Sandia National Laboratories have developed a system to train novice integrated circuit failure analysts without the live mentoring of an experienced analyst.			

<b>Item</b>	<b>Page</b>	<b>Item</b>	<b>Page</b>
<b>Concurrent Engineering Communications</b>	<b>24</b>	<b>Small Business Programs</b>	<b>27</b>
Sandia began a project to develop and demonstrate a process to rapidly transition designs of precision electromechanical devices into production.		Sandia is very active in the award of contracts to Small Business, Small Disadvantaged Business, and Woman Owned Business firms.	
<b>Department of Energy Primary Standards Facility</b>	<b>24</b>	<b>Quick Pay Invoiceless Payment Processing</b>	<b>28</b>
The mission of Sandia's Metrology Division Primary Standards Laboratory is to maintain and certify primary measurement standards for the DOE nuclear weapons complex; to continually assess the complex to ensure integrity of measurements through site-specific technical surveys and audits; and to develop new standards.		By developing the Quick Pay Invoiceless Payment Process, the Sandia National Laboratories now have a paperless invoice system that pays the supplier automatically upon receipt and validation of material.	
<b>Facilities Accelerated System Team</b>	<b>25</b>	<b>Just-In-Time Procurement System</b>	<b>28</b>
SNL created the Facilities Accelerated System Team program in 1992 to provide rapid support for production and manufacturing operations.		SNL has a Just-In-Time Procurement System designed to put general purpose items at workstations as they are needed. It is an automated ordering system designed to allow the end user/requester to place an order for commercial, off-the-shelf, low-dollar items.	
<b>Technical Surveys for Standards Laboratories</b>	<b>25</b>	<b>Total Life Concept Health Promotion Program</b>	<b>28</b>
Sandia's Primary Standards Laboratory, responsible for ensuring that all calibration and certifications performed at DOE weapons laboratories conform to standards requirements for traceability, developed a formal process to monitor and control the continued assessment of the complex.		Total Life Concept, SNL's employee health program, provides awareness and opportunity for all employees and their families to achieve and maintain physical and mental health and well-being through a supportive environment.	
<b>Non-destructive Evaluation Capabilities for Process Monitoring</b>	<b>25</b>	<b>Integrated Records System for High Reliability Production</b>	<b>29</b>
Sandia's Testing Support Center performs a unique service at the labs with several objectives: analyzing production/processes and related inspection techniques; introducing non-destructive evaluation inspection technologies; and validating inspection processes where there are opportunities to improve the product quality through a variety of non-destructive evaluation technologies.		Sandia implemented a fully integrated Records Management System to maintain and track records of high reliability components and electronic assemblies used in space and military applications.	
<b>Instructional Video</b>	<b>26</b>	<b>Nuclear Waste Management Center's Computer System Support Tracking System</b>	<b>29</b>
Facing the reality of lower production requirements, SNL implemented an instructional video program to capture specific operations and skills in many manufacturing applications.		The Nuclear Waste Management Center's Computer System Support Tracking System has been developed to establish communication with Center customers.	
<b>Small Business Initiative</b>	<b>26</b>	<b>Application of Quality Function Deployment to Battery Design</b>	<b>30</b>
As a world class leader in hundreds of scientific and technological fields, Sandia provides a national resource for transferring technology to small business.		Sandia uses the Quality Function Deployment process as the organizational aid in integrating the ability to determine product requirements from customers' needs and expectations, and ensure that these requirements are realized in a product or service.	

<b>Item</b>	<b>Page</b>	<b>Item</b>	<b>Page</b>
<b>Evaluation of Low-Noise Seismometers</b>	<b>31</b>	<b>Laydown Weapons Parachutes</b>	<b>34</b>
Sandia is chartered by the Department of Energy and Department of Defense to evaluate seismic data acquisition systems to monitor international treaties limiting nuclear weapons underground testing. SNL developed a shotgun borehole testing system for testing seismometers using coherence analysis.		Sandia maintains the responsibility for development, production, and stockpile maintenance for Laydown Weapons Parachutes through a Parachute Development Laboratory and a Parachute Materials Quality Assurance Laboratory which provides analysis and experience in high-speed, low-level Air Dynamic Deceleration Systems.	
<b>Advanced Manufacturing Technology Network</b>	<b>31</b>	<b>A-PRIMED Process Improvements</b>	<b>34</b>
An Advanced Manufacturing Technology Network allows internal and external network communications to use a broad range of communications protocols from WAN environments to high speed dial-up using PC modem connections.		SNL's A-PRIMED project is a strategy for fast-tracking design and implementation of components.	
<b>1.3 INFORMATION ITEMS</b>		<b>Laser Spot Weld Representation</b>	<b>34</b>
The BMP survey team identified the following items as informational at SNL:		Although current CAD systems model part geometry very well, they are limited in their ability to model assemblies and the "liaisons" between components. SNL has extended their design system to represent one type of liaison information between components, specifically welds.	
<b>Item</b>	<b>Page</b>	<b>Concurrent Engineering in the Recode System and Thermal Batteries</b>	<b>35</b>
<b>Controlling Manufacturing Costs Using Activity-Based Costing</b>	<b>33</b>	Two programs at Sandia National Laboratories highlight what can be achieved using the concurrent engineering process. This approach was demonstrated in the successful development of thermal batteries and in a secure recode system development.	
The Service Center Information System is a computer-based cost tracking system that allows Sandia National Laboratories management to control sizing of various activities by funding only those services used within a process.		<b>Control Device Database/Measurement Software</b>	<b>35</b>
<b>High Consequence System Surety</b>	<b>33</b>	Sandia's Primary Standards Laboratory is developing software for a more efficient method for capturing, displaying, and storing data generated during the certification of microwave Vector Automatic Network Analyzers.	
SNL has brought together a multidisciplinary team to integrate the various elements of surety, safety, security, control, reliability, and quality into a new and encompassing process that will provide systems with insurance against unintended adverse consequences.		<b>Utility Battery Storage Systems Program</b>	<b>36</b>
<b>Electronic Design Automation Process</b>	<b>33</b>	The Utility Battery Storage Systems Program, sponsored by the Department of Energy and directed by the Storage Battery Department at Sandia, cooperates with the electric utility and manufacturing industries to develop battery storage systems.	
The Monitoring Systems and Technology Center of Sandia National Laboratories is an engineering collective with a core competency in designing, building, and testing of high reliability satellite spacecraft payloads.			

Item	Page	Item	Page
<b>Engineering Analysis Contribution to Agile Manufacturing</b>	36	<b>Software Process Improvement</b>	38
SNL addressed the problem of providing an automated finite element mesh for stress and thermal load calculations in agile manufacturing and fast prototyping by developing a software package called CUBIT.		An SNL Quality Engineering Department team tailored SEMATECH's software products improvement process to address the lack of a company-wide policy on software management.	
<b>Engineering Simulation for Model-Based Design</b>	36	<b>Computer-Aided Molecular Design — Fullerenes</b>	39
The Engineering Sciences Center at Sandia has an analysis capability comparable to many engineering and manufacturing companies, and is currently integrating its computational capabilities into an engineering "toolkit" for both conventional and many leading-edge analysis problems.		Sandia National Labs performed computer-intensive quantum chemistry modeling to determine the structure and energetics of a newly discovered allotrope of carbon named a fullerene.	
<b>Fuzzy/Probabilistic Hybrid Analysis</b>	36	<b>Electrical System Simulation and Analysis</b>	40
The System Studies Department and the Assessment Technology Department of Sandia are developing methods for using fuzzy logic to deal with unexpected or abnormal-environment assessment.		To reduce test costs and obtain more insight into their designs, the SNL have begun using CAD tools to design and simulate analog designs.	
<b>Integrated Assembly Planning</b>	37	<b>Virtual Collocation of Product Realization Teams</b>	40
Because modern products have more parts, are designed faster by different designers, and are packed into a smaller volume, Sandia performs automatic assembly planning to aid in manufacturing.		Sandia National Labs assembled a multidisciplinary product realization team to design, develop, and validate a new telemetry system for defense applications. This team was composed of personnel from three remote sites.	
<b>Microporous Polyimide Films for Reduced Dielectric Applications</b>	37	<b>Integrated Development Environment and Assistant Program</b>	41
Strong demand for fast, highly-condensed microcircuits and the unavailability of low dielectric-constant insulators has led Sandia researchers to look for alternative methods to insulate multiple layers of patterned conductors in multichip modules.		Sandia is developing an Integrated Development Environment and Assistant program that will provide easy and guided access to electronically accessible knowledge, information, and tools in an integrated development environment.	
<b>Agile Cable Acquisition and Production System</b>	38	<b>Optical Studies of Diesel Engine Combustion</b>	41
In partnership with Lockheed Missiles and Space Company and Stanford University, SNL's Livermore site is assisting in the development and deployment of an Agile Cable Acquisition and Production System. This system allows a cable purchaser to submit design specifications, obtain price quotations, and negotiate the procurement of cable systems electronically via the Internet's World Wide Web.		SNL, in partnership with Cummins Engine Company, constructed a model of the dynamics occurring during diesel engine combustion in support of development of a clean, efficient diesel engine without reducing performance or reliability.	
		<b>Virtual Company</b>	42
		SNL established a virtual company with many of their suppliers to address problems associated with manufacturing prototypes to print.	
		<b>Evaluation of High Resolution Digitizers</b>	43
		At SNL, a suite of tests has been developed to characterize high resolution digitizers by using coherence analysis.	



Item	Page	Item	Page
<b>Software Unit Testing</b>	44	<b>Automated Cleaning of Electronic Components</b>	47
Sandia National Laboratories' Surety Assessment Center developed a process guidebook to help improve past practices in software unit testing.		Because of high reliability requirements of their products, SNL pays particular attention to all manufacturing process steps that could impact that reliability, including cleaning.	
<b>Process Characterization Methodology</b>	44	<b>Automated Assembly Planning</b>	47
Process Characterization Methodology at Sandia facilitates Product Development Teams to systematically transition a product from design to efficient and controlled manufacturing processes.		Sandia National Laboratories are currently working on an automated assembly planning tool as part of the A-PRIMED project.	
<b>Cable Tester</b>	45	<b>Two-Phase Supplier Selection</b>	48
The SE3262 Cable Tester was developed to update a slower, manually-operated megohmmeter-based continuity and highpot tester.		Sandia National Laboratories went through a two-phase selection process to establish a supplier of the H-1616 Tritium Reservoir Shipping Container.	
<b>Low Volume Statistical Process Control</b>	45	<b>Shielded Plasma Cleaning for Package Assembly</b>	48
Sandia is developing low volume statistical process control to apply to its small quantity of products produced. The method used to evaluate the process involves an algorithm which updates the estimate of a time-varying mean whenever more data becomes available. This type of estimate is more effective than the usual sample average when the process mean varies over time.		In response to the elimination of ozone-depleting solvent use and in an effort to improve the quality and reliability of their microcircuits manufactured on-site, SNL has instituted a change in the cleaning process for microcircuits.	
<b>Solid Model/CNC Programming</b>	45	<b>Manufacturing Prototyping Facility</b>	49
Sandia National Labs instituted CNC programming to help integrate product design and manufacturing.		In October 1993, the SNL facility at Livermore established a Manufacturing Prototyping Facility to support prototyping and integrating advanced manufacturing technologies.	
<b>An Expert System to Support Green Design and Manufacturing</b>	46	<b>Preventive Maintenance</b>	49
Sandia has developed EcoSys™, an information system and expert system for demonstration of environmental impact analyses of product designs and processes.		SNL upgraded its preventive maintenance effort through the installation of a PC-based preventive maintenance program.	
<b>A-PRIMED Robotic Workcell</b>	46	<b>Sandia Voice Information System</b>	50
A robotic workcell has been designed and built at Sandia to perform manufacturing validation tests for A-PRIMED discriminator devices and to assemble these devices in low volumes.		Sandia's Voice Information System uses voice information throughout the lab as an enabling technology for productivity enhancement providing voice mail, faxing, information delivery, interactive voice response, and other information connections.	
<b>Engraving Complex Layouts Directly from CAD Files</b>	47	<b>Nuclear Waste Management Program Administrative Information Management System</b>	50
The Electronic Fabrication Department at SNL can take CAD data files produced on various platforms throughout the facility and convert them into CAM programs for CNC engraving machine operations.		The Administrative Information Management System is an integrated network of databases which functions to provide project management information to technical projects within the Nuclear Waste Management Program.	

<b>Item</b>	<b>Page</b>	<b>Item</b>	<b>Page</b>
<b>Benchmarking for Waste Minimization Project</b>	<b>51</b>	<b>President's Quality Award</b>	<b>54</b>
After finding that information on waste minimization was not readily available to specific generators of Department of Energy waste, Sandia concluded that a benchmarking project needed to be implemented to obtain meaningful information on the best practices available.		At the request of Sandia's President, a team of Sandians began translating Malcolm Baldrige award principles into an internal set of criteria to encourage best practices within the laboratories and recognize those that have been successful in applying TQM principles.	
<b>Computer-Aided Acquisition and Logistics Support Operational Network</b>	<b>51</b>	<b>High Voltage Pulse Generator and Calibration Equipment</b>	<b>56</b>
Over an 18-month period, an SNL Process Quality Management and Improvement Team developed a Computer-Aided Acquisition and Logistics Support Operational Network Process to streamline nuclear weapon maintenance manual generation.		Sandia redesigned and rebuilt the High-Voltage Pulse Generator for state-of-the-art operation using a computer-controlled system with user-friendly software. This generator is primarily used for calibrating precision high-voltage dividers.	
<b>Electrical Seamless Manufacturing Team</b>	<b>52</b>	<b>Transitioning Existing Weapon Designs into Manufacture</b>	<b>56</b>
In mid-1990, SNL in California formed an Electrical Seamless Manufacturing Team in response to several issues requiring improvement.		In response to the withdrawal of commercial suppliers, Sandia developed its own capability for manufacturing War Reserve active ceramic components using a TQM approach.	
<b>Technologies Enabling Agile Manufacturing</b>	<b>52</b>	<b>Qualification of Weapon Processes and Product</b>	<b>56</b>
Technologies Enabling Agile Manufacturing was formed to deploy integrated, validated design-to-manufacture tools and to identify processes that streamline product development, reduce costs, enhance quality, and shorten cycle time.		To ensure effective future determinations that product design and associated manufacturing and acceptance processes would be capable of providing a product that meets customer requirements, Sandia National Laboratories participated in the development of a Nuclear Weapons Complex-wide Engineering Procedure.	
<b>Benefits Services</b>	<b>53</b>	<b>Sandia Volt Map Program</b>	<b>57</b>
The Sandia Health Planning and Administration Department manages cost effective products and services through a total integrated health care process.		Sandia has used a Volt Map program for more than 20 years to certify Contractor Standards Lab cell banks for the Zener Voltage Program. Specially designed transport cell banks are used for the maps.	
<b>Processes Developed for Test and Evaluation</b>	<b>54</b>		
SNL drafted a plan to develop formal process developmental procedures in response to a 1991 Department of Energy investigation into accidental damage to a test item. The Department of Energy identified a number of contributing issues with a lack of "formalized processes" as the most prevalent.			
<b>Systems Engineering</b>	<b>54</b>		
Sandia began developing Systems Engineering as an interdisciplinary activity in 1993 to ensure customers' requirements would be met throughout the system's life cycle.			

## **1.4 ACTIVITY POINT OF CONTACT**

For further information on any item in this report, please contact:

Larry O'Connell  
Sandia National Laboratories  
Project Development Department  
P.O. Box 5800, MS 0955  
Albuquerque, NM 87185-0955  
Phone: 505-844-1061  
FAX: 505-844-5422  
email: ljoconn@sandia.gov

# SECTION 2

## **BEST PRACTICES**

---

### **2.1 DESIGN**

#### **DESIGN REQUIREMENTS**

##### **Preferred Design Processes and Practices for Flight Hardware**

The Advanced Digital and Power Subsystems Department of Sandia National Laboratories (SNL) developed two documents to provide standardization of processes and practices in space-based electronic payload design. These critical documents were compiled to capture personnel knowledge and expertise acquired during 30 years of development of electronic packages and power supplies for various satellite payloads. Using these documents has allowed Sandia to train new personnel and provided an easier communication path to potential customers.

The documents encompass flight hardware for satellite payloads with sections on general guidelines/philosophies, preferred process phases such as system design, preliminary design, detailed design, implementation and test, integration and test, launch, and post-launch. The section on preferred practices addresses electrical, mechanical, environmental, robustness, safety, troubleshooting, and documentation.

Training new personnel in technical aspects has required almost 90% less time by applying the information contained in these documents, by focusing on previous problems identified from past experience and suggesting proven solutions. In addition, there is enhanced communication outside the department and standardization within it. These documents also provide a standard for performing quality reviews and reduce project costs by ensuring the job is done right the first time, and finally, the process is dynamic as new lessons from continuing experience are incorporated into the guideline documents.

##### **Department of Energy/Department of Defense Environmental Data Bank**

As the responsible agent for the nation's nuclear weapon stockpile, Sandia National Laboratories' Environments Engineering Group maintains the Department of Energy (DOE)/Department of Defense (DOD) Environmental Data Bank. This data bank contains information on identification and quantification of environments the weapons are expected to withstand.

The data bank contains information on specific environments encountered during normal conditions such as transportation, handling, and storage; abnormal conditions such as fire, lightning and impact; and environmental conditions such as chemical, humidity and pressure. The bulk of this information is stored on physical media such as paper and microfiche and is susceptible to deterioration. Computer storage has only recently become an economical option for data to be placed, stored, and maintained electronically through a program called SPEEDI II. When the data is available on-line, it allows for improved alternatives such as test selection. Actual test data and test reports can also be included.

Other related efforts maintained by the Environments Engineering Group include the LUGSAN II. LUGSAN II is an aircraft compatibility environments analysis package which can perform lug and sway brace analysis calculations for the designer. The designer may input various aircraft, rack designs, maneuvers and hardware, and the system will perform rigid-body analysis to determine the loads to which the weapon will be subjected. SNL estimates that the program alone has reduced turnaround time on this type of analysis from two weeks to one day. SNL anticipates making this program available to the aircraft manufacturing industry.

In addition, the Aging Aircraft Specimen Library Database will be a database to allow a user to point and click on a particular aircraft section for information on all inspection results, Federal Aviation Administration (FAA) regulations pertaining to that part, and any problems associated with that area. SNL maintains that the structure of this database could be directly applicable to other industries such as medicine.

##### **Model-Based Design and Virtual Prototyping**

SNL has developed a Model-Based Design team to provide engineering personnel with the capability to design products and develop or improve processes using computer generated virtual prototypes. Virtual prototyping consists of creating new products within a computer and analyzing them for form, weight, size, and critical mechanical, electrical, and thermal properties before producing a physical product. Benefits of virtual prototyping include the ability to observe the design in three dimensions, the ability to assess trade-offs within the product and processes, reduced design time, and a reduction in pre-production hardware. Model-based design often requires a mesh or solid-based

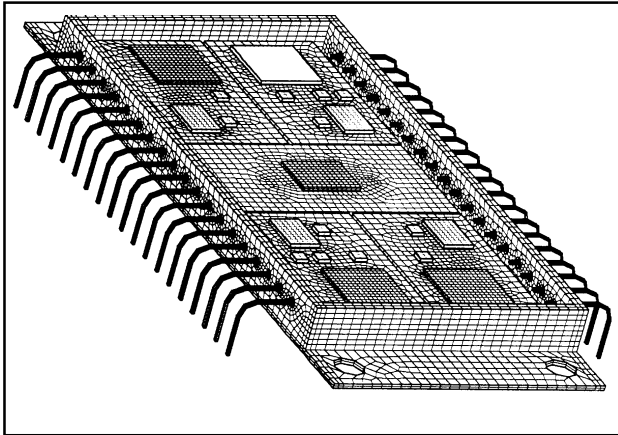

**FIGURE 2-1. MODULAR ADAPTABLE CONTROLLER**

modeling system for spatial-type analysis. One advantage of this model is that it can be used for scientific analysis as well as design.

SNL used model-based design to create a virtual prototype for the output module from a Modular Adaptable Controller-based weapon programmer design (Figure 2-1). The output module consisted of eight power Metal Oxide Silicon Field Effect Transistors and a voltage level-shifting ASIC. The virtual prototype used an electronic circuit model, solids model, and a 46,000 element thermal mesh. Commercial modeling software was coupled to computer code developed at Sandia to study thermal management issues. This was used to predict the circuit behavior in reaction to internally-generated heat over an eight-second operational lifetime. Trade-off analysis performed with the virtual prototyping proved that multiple substrates, including isolating the ASIC on a single alumina substrate, were preferable to a single substrate of aluminum nitride. Although this option created the added expense of intersubstrate wire bonding, it protected the ASIC from excessive heat, allowing the device to perform as desired for the entire test.

Model-based design has been used in other areas to reduce costs and shorten cycle times. Sandia develops Synthetic Aperture Radar antennas using parametric and virtual prototyping methods. Traditionally this process would require almost a year of iterative prototypes and calibrations. Using model-based design to create a solid model reduced this time to two to four weeks. The design was verified within the computer, and a physical solid model was then created using stereolithography. The plastic model of the radar dish was coated with copper; calibration was performed, allowing the final design to go into production in less than four weeks.

Sandia also applies model-based design in the use of stress analysis tools. Allied Signal/Kansas City Division (a manufacturing partner of Sandia) analyzed certain types of

lead forming to determine if tighter radius lead bends could be used to increase component density, thereby allowing for flexibility in component spacing problems.

Sandia and Allied Signal are using model based product realization to reduce costs and cycle times. They are currently using models to evaluate thermal management and stress distributions and are also programming wire bonding equipment on virtual components to reduce setup times and errors during programming. Future work will include analysis of electromagnetic, thermal-stress, and mechanical systems, as well as the integration of modeled subsystems into higher level systems.

## DESIGN ANALYSIS

### Multi-Dimensional User-Oriented Synthetic Environment

The SNL-developed Multi-Dimensional User-Oriented Synthetic Environment is a leading edge virtual environment which demonstrates new approaches for interacting with computer-based information. The virtual reality environment of the Multi-Dimensional User-Oriented Synthetic Environment integrates high performance computer graphics imagery, audio, and input devices to provide users with an enhanced capability to examine, question, and understand relationships in complex information space.

Initiated in 1991, Multi-Dimensional User-Oriented Synthetic Environment can investigate new approaches for multidimensional representation of complex information. It provides an open software system that simplifies development of interactive graphical models and software, provides a device-independent framework for dynamically presenting information, and creates a user-controlled environment to enhance the speed of human perception of that information. The Multi-Dimensional User-Oriented Synthetic Environment system is a software shell that integrates a number of software systems and hardware devices to provide an integrated environment. High performance graphics are generated by a Silicon Graphics ONYX™ workstation, and interfaces include a boom video display, room projection system (with three-dimensional viewing through Crystal Eyes™ glasses), a voice control and voice response mechanism, and an auditory display for mapping technical data into sound (with pitch, amplitude, and voice variation).

The Multi-Dimensional User-Oriented Synthetic Environment project has developed several demonstrations of this technology on real world applications such as manufacturing design and assembly analysis, operation of a multi-chip module (circuit simulation, thermal conductivity, stress analysis), data analysis of seismic information, medical imaging of a human head, and dynamic simulation of explosive welding. Project staff have been able to rapidly

integrate applications data in a variety of formats from different applications such as ProEngineer, SPICE, and finite element systems.

## Automated Mesh Generation for Engineering Analysis

SNL successfully applies meshing algorithms for finite element analysis. These meshes are generated throughout a manufactured part's geometry and are used to analyze the effects of externally applied loading on the component.

Sandia recognized that mesh generation impeded the improvement of analytical throughput. Traditionally, only simple mapped meshing algorithms existed and those required manual geometry generation. This was time consuming and expensive as it required engineers skilled in finite element analysis to generate the mesh. Complicated real-world geometries were not amenable to mapped meshing. These geometries first had to be decomposed into simpler geometric shapes before an analyst could generate the mesh, resulting in unproductive time recreating existing geometries already available through standard CAD files.

Sandia developed a three-dimensional surface paving algorithm, providing SNL the ability to automatically mesh arbitrary geometries and control the mesh densities via an advancing front algorithm. Once the mesh was generated for a part, it could then be surface projected through the part's thickness (Figure 2-2) to generate a two-and-a-half dimension volume mesh.

In addition to the paving algorithm, SNL also developed the CUBIT mesh generation toolkit. This toolkit provides an advanced code architecture for meshing algorithm research.

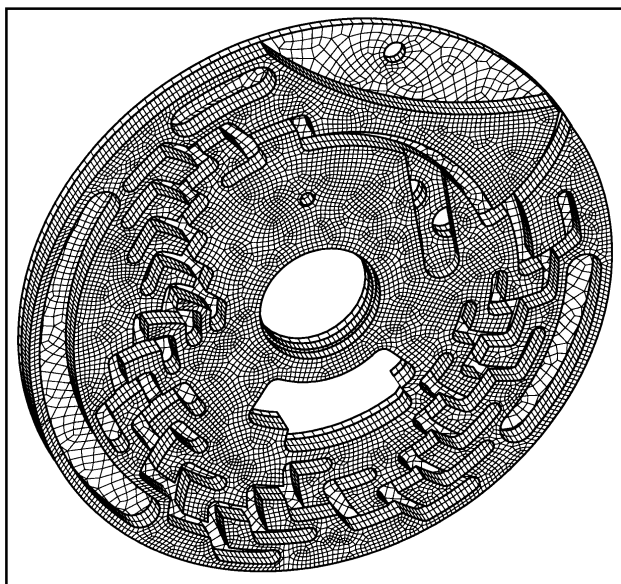

**FIGURE 2-2. MAZE WHEEL**

It is solid modeler-based to accommodate advanced geometries. CUBIT also combines research and development platforms so experienced analysts can immediately use the code.

Sandia continues to advance in this area by developing additional meshing algorithms. The labs have recently developed the ability to perform submapping (semi-automatic decomposition) and sweeping, which generates two-and-a-half dimension volume meshes from paved or mapped surface meshes, to improve the mapping algorithm. Additionally, Sandia is researching automatic hexahedral element generation via two techniques known as plastering and whisker weaving. This will provide next generation systems with a true three-dimensional capability.

Sandia's efforts in this area have resulted in a number of benefits. The paving software was recently benchmarked by Ford Motor Company as having reduced modeling time from 36 hours to 1/2 hour. This algorithm – together with the CUBIT toolkit – is also being used by Goodyear Tire and Rubber and the USCar initiative as the mesh generator of choice. Sandia is also leveraging this technology with its Fast Casting Process and nuclear surety programs.

## Reliability Analysis and Modeling Program

SNL developed a PC-based Reliability Analysis and Modeling Program to integrate data management, model development, model analysis (with uncertainties), and graphic output. This software allows engineers to design for reliability and analyze maintenance strategies.

The initial step in using the program is to develop a fault tree model of the component or system to be analyzed. This model is a tree that identifies all factors which could cause a system to fail, and probabilities associated with each type of failure event. The software calculates mean time between failures, mean time to repair, and failure probability. Other software functions include calculation of reliability and maintenance costs, and identification of contributors to downtime, failure rate, and system unavailability. Example graphic outputs include contribution to system failure histograms, system availability graphs, and a text-based model of the fault tree.

The software has been used in a number of design-for-reliability and maintenance analysis cases. In a maintenance strategy analysis case, the software was used to re-evaluate and optimize the spares included in a repair kit. Benefits included a 58% improvement in mean time between failures, a 62% increase in uptime, and up to a 59% increase in throughput. The software has helped engineers make clear choices between design alternatives when considering reliability factors.

More than 250 alpha test copies of the software have been provided to industry partners along with a two-day training course on the software, sensitivity and uncertainty analysis, and reliability modeling.

## DESIGN PROCESS

### Advanced Manufacturing Software ToolKit Environment

SNL has developed an Advanced Manufacturing Software ToolKit Environment, a technology utilized by the FASTCAST consortium of approximately 20 U.S. casting manufacturers for designing gating systems for investment cast parts. The ToolKit is also used by Glass-to-Metal Seals, a project to design and hermetically seal compression pin seals used in electronic connectors. Potentially, the ToolKit technology can be extended to any manufacturing application. The ToolKit integrates people, processes, activities, and knowledge coupled with emerging computer technologies to reduce the time required to manufacture high quality products. This toolkit was developed to alleviate the problems associated with cut-and-try methodologies currently being used as well as to address the problem of disjointed enabling technologies.

The strategy behind the development centered on establishing customer requirements and defining the deliverables and information model. Next, the scripts necessary to generate the codes for the software processes were developed. Then, an inventory of reusable software was established. This was leveraged from other successful software application projects. Finally, an approved graphical user interface was developed to provide the form, fit, and feel of the system. Design process steps are documented for a well-defined manufacturing application; software applications and their requirements are defined; rules, inputs, outputs, results and constraints are collected in a common repository; and finally, customer requirements are implemented in a flexible integrated open architecture.

This system provides integration of customer-defined analytical software packages which enable a manufacturer to perform all necessary analysis from design through manufacture. The initial version of this tool was tailored for the investment casting industry where most small job shops

were ill-equipped to accomplish the entire spectrum of analysis required.

The Advanced Manufacturing Software ToolKit has the ability to integrate a customer's existing software packages into a seamless analytical tool. Coupled with the Advanced Manufacturing Technology Network, this technology will continue to grow and help provide American manufacturers with a competitive edge.

### Structural Dynamics and Vibrational Control

SNL performs computational and experimental structural dynamics analyses including optimization, structural system identification, vibration/chatter control, and smart structures and materials. State-of-the-art computational analyses and control of structural vibrations represent the hallmark of this process at Sandia.

Computational structural dynamics involves the development of finite element or boundary element models of structures and systems and their use for design verification, analyses, and design optimization. Structural system identification encompasses the process of integrating analytical and experimental structural dynamics techniques which can lead to automated methods for calibrating structural dynamics models with measured data as well as the ability to account for uncertainties in both the data and modeling parameters.

Sandia also is developing structures and materials that respond to internal and external stimulation through sensing, actuating, processing, and control. These lightweight, "smart" material systems can replace bulky mechanical devices in some applications and perform more reliably over a longer period of time with lower maintenance.

Sandia's work on smart structures and materials for weapons and space programs is being applied to commercial applications in manufacturing, microelectronics, and transportation. For example, SNL is working with analyses of flexible robotic arms and assemblies, precision lithography machines, machine tools for chatter suppression, and collaborating with the automotive industry on better design and analysis methods. Figure 2-3 illustrates a basic layout for

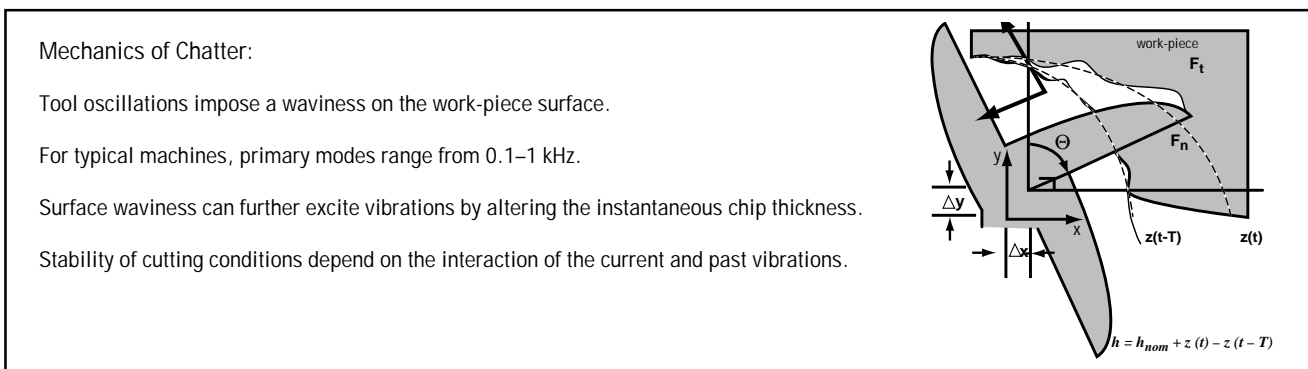

**FIGURE 2-3. BASIC LAYOUT FOR ANALYZING CHATTER IN THE MILLING PROCESS**

analyzing chatter in the milling process. Sandia's efforts have led to enhanced quality, more accurate, and faster manufacturing processes. Information and assistance in these areas are available to small and large businesses through a National Machine Tool Partnership and through the laboratories' Technical Information Environment – for Industry (TIE-In) computer network which can be accessed through the Internet World Wide Web.

## Vector Automatic Network Analyzers Certification Approaches

The Primary Standards Laboratory (PSL) has developed a process for the certification of microwave Vector Automatic Network Analyzers (VANAs). These network analyzers are used to make moderately low uncertainty Scattering (S) parameter measurements rapidly and at many frequencies. S-parameters of an n-port device characterize how the device interacts with signals presented to the various ports.

Tables of uncertainties for scattering parameter measurements made by Hewlett Packard Models 8510 and 8753 VANAs are readily generated using computer software procedures. Typically, the uncertainties for a given scattering parameter measurement are tabulated as a function of frequency and the measured parameter (such as reflection coefficient). The uncertainties are deduced from network error models for the particular VANA system and scattering parameter. For reflection scattering parameters, the Thru-Reflect-Line technique is used to deduce the parameters of the model. The process involves the measurement of several air line standards and the analysis of the resulting data using different models depending upon the parameter being certified. The level of confidence assigned to the calculated uncertainty can be chosen by the operator from 81 to 99%.

The program consists of three sections, the first section certifying the performance of the HP VANA when making complex reflection coefficient measurements. Section two certifies the performance of the HP VANA when measuring the magnitude of attenuation, and section three certifies the performance of the HP VANA when measuring the attenuation phase angle. The output from each of the three sections consists of tables showing the uncertainties of the HP VANA in making the various measurements. An on-line feature of the software is a simulation capability against which data may be run to validate the software performance.

The process software uses HP BASIC 5.1 and is menu/prompt driven, requiring few auxiliary instructions to run it. User guide documentation is included as comment files within the program.

## Parent-Child Design Paradigm

The Sandia National Laboratories' Agile Product Realization of Innovative ElectroMechanical Devices (A-PRIMED) Project has initiated a new design "parent-child" program where the "parent" refers to a class of products and "child" to an instance within the class (Figure 2-4). SNL maintains that if multiple variants of a new product are inevitable, then it is necessary to plan for the variability. By initiating this new framework, Sandia is able to plan production processes and facilities that address all child products and automate design and manufacturing tasks related to design variations. Also, parameter space qualification contributes to an agile product realization process.

The parent-child paradigm is a proactive design which attempts to predict and plan for all product variations up front. Although similar to variant design, it differs in that variant design normally addresses variations and repercussions after an initial design has been created. Parametric design provides capabilities for controlling geometric relationships between features in a product. A parent-child design uses parametric design and other technologies for product/process development and qualification.

Sandia has applied the new paradigm to the development of a complex product such as a maze wheel (a strong link device). Some examples of the design constraints that were considered for such a product include the number of codes supported, stresses to which the component may be subjected, component size, weight, and speed of operation. One major benefit of this approach is to ensure that all future instances of this class of product can be produced using the same manufacturing facilities and processes.

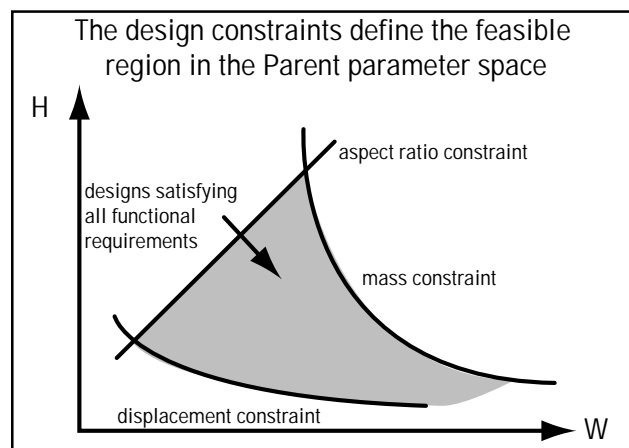

**FIGURE 2-4. DESIGN CONSTRAINTS PARAMETER SPACE**

## SOFTWARE DESIGN

### Sandia Preferred Processes for Software Development

SNL established preferred processes for software development to satisfy internal standardization, external standards, and customer requirements. The initial goal was to demonstrate technical benefits achievable through a team effort.

Software developers at Sandia represent most stakeholders for the preferred processes for software development. Team representatives include a Process Analyst, Process Quality Management and Improvement Consultant, Management Advocate, Education and Training Representatives, and Software Quality Managers. The teams meet on a regular schedule and review processes that address DOE orders, DOD Standards, and Sandia's Strategic Plan. The teams also conduct research into standards for software development, and identify and evaluate alternative core processes such as software requirements, design, and implementation. Software life cycle models, design processes,

test processes, and review techniques are also considered preferred processes for software development.

Process definitions include a step-by-step description of what should be performed for a specific phase of software development. Flexibility is built into the independent methodology to avoid dictating how each task to be is accomplished. The process is measurable for improvement, repeatability, control, and scalability.

The preferred process for software design includes definitions for overviews, entrance criteria and inputs, process summary tables, exit criteria and outputs, process changes, expected improvements, metrics, tools, training, documents and detailed task descriptions (develop and review products). Detailed task descriptions include objectives, dependencies, responsibilities, inputs, entrance criteria, task descriptions, verifications, exit criteria, outputs, and standards.

The software development process begins with a set of requirements, and the design process tasks consist of eleven steps (Figure 2-5). Templates have been developed for document control for software requirements specification, design description, system test plans, and DOD Standards.

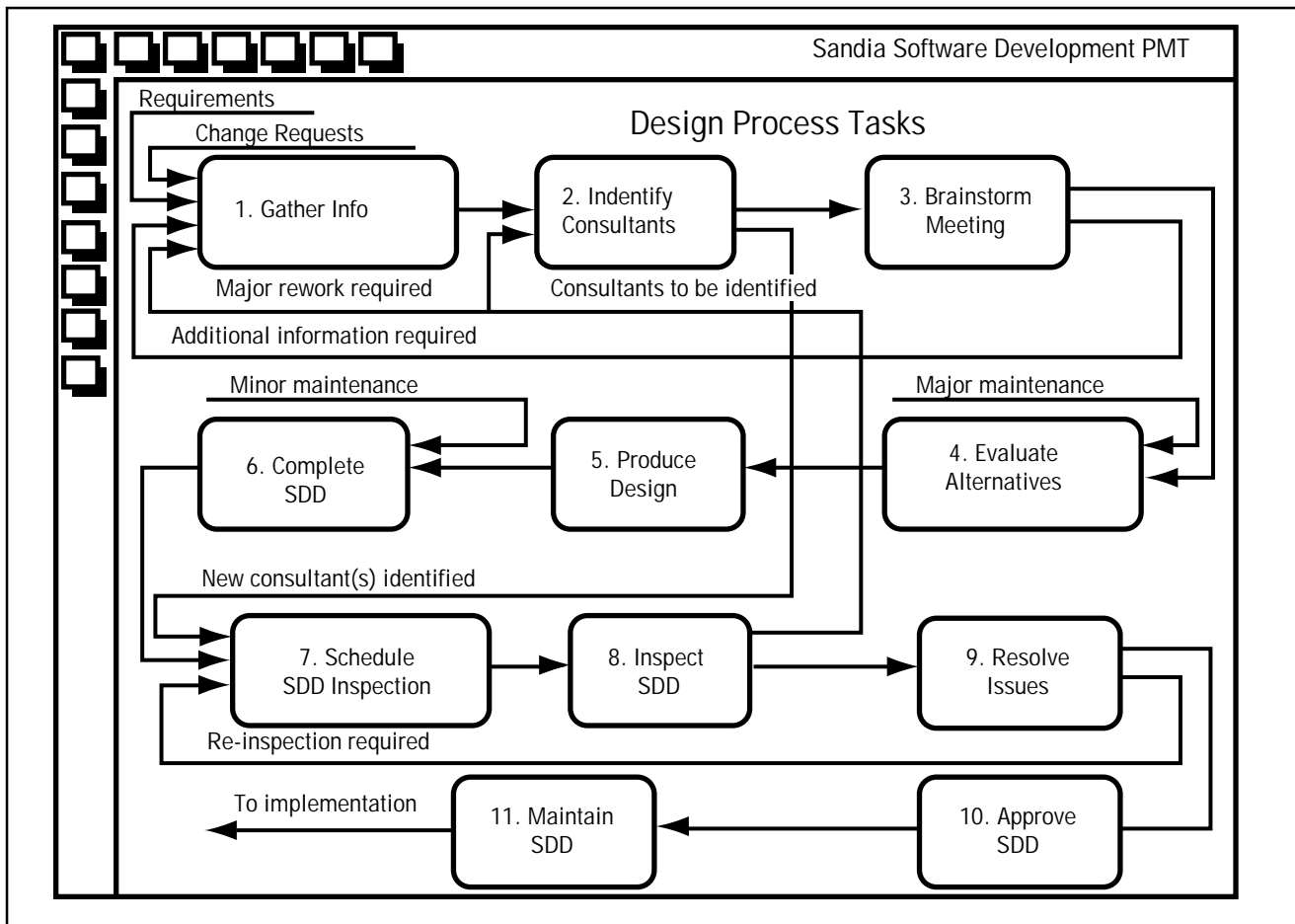
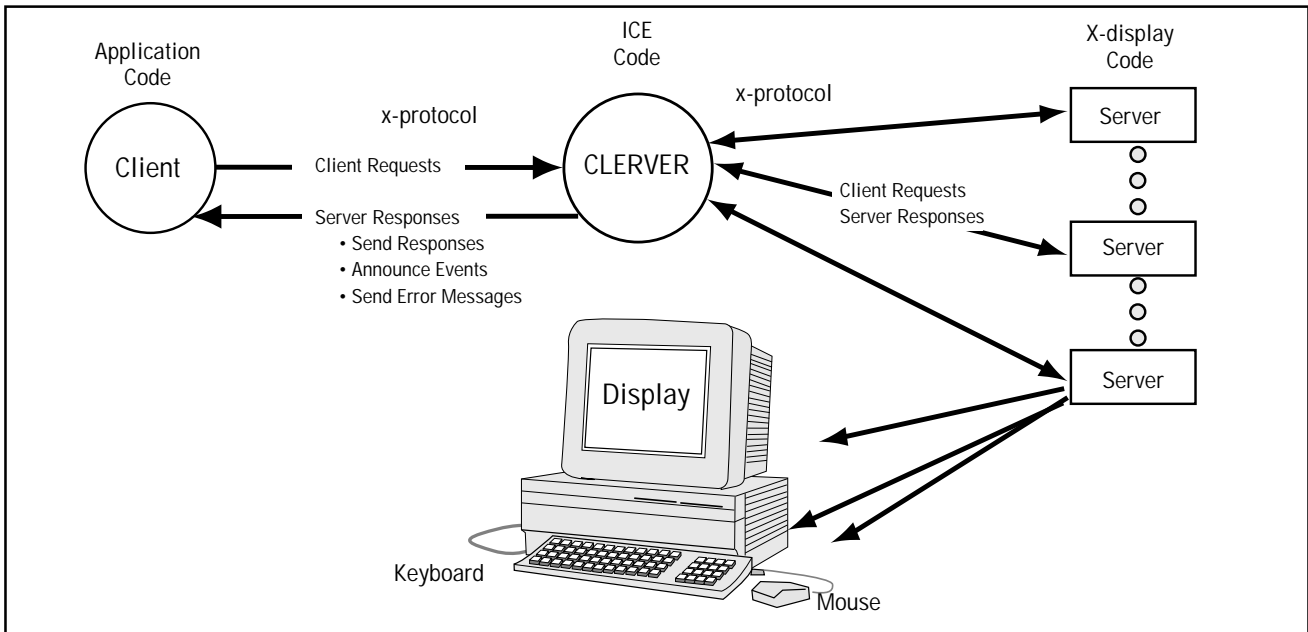

FIGURE 2-5. DESIGN PROCESS TASKS





**FIGURE 2-6. CLERVER SOFTWARE**

Templates also include definitions, acronyms, references and overviews.

To control new requirements and feedback, forms are used to report request for change, inspection, and test information. Inspection and test forms include profile, management report, defect lists, summaries, system test logs, and system test incident reporting.

Other alternative methodologies have been approved. Guidelines have been established to control the document process for approval, and most document approvals do not require two reviews.

Socialization has been established for template distribution, presentations, software preferred processes, Technology Transfer Center presentations, and In-hours Technical Education Courses (INTEC). INTEC consists of Software Engineering, Overviews for Management, Structured Analysis, Structured Design, Software Quality Engineering, Software Inspection, and Software Measurements. The Socialization by Organization Team is comprised of 278 INTEC course participants and 224 document and template requesters. The Sandia preferred process for software development team has established a considerable list for private industry external distribution.

By actively soliciting suggestions for improvements, Sandia has decreased the required time and effort to produce documentation, while seeing a significant savings due to early detection of defects. Formal development methodology has fostered increased productivity results. Changes and improvements will continue with the development and implementation of feedback surveys.

## COMPUTER-AIDED DESIGN

### Interactive Collaborative Environments

Computer scientists at Sandia National Laboratories have developed a concurrent engineering tool that will allow project team members physically isolated from one another to simultaneously work on the same drawings. The technology is called Interactive Collaborative Environments (ICE), a software program and networking architecture that supports interaction of multiple X-Windows servers on the same program being executed on a client workstation.

The ICE application implemented at Sandia is a software program that makes it possible to share X-Windows application programs in a network. The application program executing in the X-Windows environment on a master computer can be simultaneously displayed, accessed, and manipulated by other interconnected computers as if the program were being run locally on each computer. The ICE program acts as both a client and a server. It is a server to the X-Windows client program that is being shared, and a client to the X-Servers that are participants in the collaboration. This client-server program intercepts and manages the data and protocol (Figure 2-6). It also resolves any differences between the X-Servers involved in the collaboration such as colors, fonts, and resource IDs. This allows the participants to transparently use their own UNIX, PC, or Macintosh X-Servers.

The X-Windows application demonstrated is a mechanical design package called ProEngineer, and is one of the

---

cornerstones of the A-PRIMED concurrent engineering project. The ICE implementation makes this CAD package a true concurrent engineering tool. Designers, production engineers, and the other groups can simultaneously sit at up to 20 different workstations at different geographic locations and work on the same drawing since all participants see the same menu-driven display. Any and all of the stations, if given permission by the master/client workstation, may edit the drawing or point to a feature with a mouse, and all workstation pointers are all simultaneously displayed. Changes are immediately seen by everyone.

## Nuclear Safety Information Center

In 1989, the nuclear safety organization undertook an improved program to achieve rapid retrieval of the existing documents and create a specific repository to ensure capture of graphics files, internal correspondence, engineering analysis, engineering records/notes, and meeting minutes. This led to use of a best effort approach to track down critical data and correspondence related to these design features. In addition, the DOE and SNL had a need for storage and ready access to pertinent nuclear safety related information that would facilitate weapon system analyses and capture historical information on an ongoing basis.

The Center uses a PC, MS-Windows-based database system called AskSam™ (ver.2.0) to provide image and text management for the Archival Management System. A key attribute to successful implementation of this system has been a bar code assignment to each document received for archival, giving it a unique identifier code which is electronically readable.

Over 42,000 documents have been stored onto the system by a staff of three, and search time for engineers involved in this design change process has been significantly decreased.

## CONFIGURATION CONTROL

### Pentagon-S: Safety Critical Piece Part and Defect Control

Sandia's Systems Surety Engineering Department introduced a new centralized Pentagon-S process to identify safety critical design features and their manufacturing controls for high-risk, high-consequence products and processes. Traditionally, a Pentagon-D or Pentagon-M notation on a design print was annotated by design and manufacturing engineers for quality control, indicating to manufacturers the degrees of freedom to deviate from specified tolerances, materials, or processes. The annotation also outlined required pedigree quality control procedures to capture this information during the production process. This process did not consider how and why safety control features were

developed, what engineering safety analysis was performed, and the history of these features in production.

The new process is a multi-organizational team approach that works to define at a systems level review what features, processes, assembly, inspection, testing, specification, or materials are determined to be safety-critical features. System analysis tools are used (e.g., probabilistic and fault tree analysis) to determine what anomalies would potentially cause catastrophic events. The process helps the customer weigh safety requirements against other system requirements and understand the consequences of not implementing certain Pentagon-S controls.

With the Pentagon-S convention implemented, Sandia has demonstrated that safety is not just a concept, it is an attempt to control the effects of manufacturing on safety-critical features. In a pilot program, Sandia successfully demonstrated an increase in production yield from 91% to 99% in the design for a Lightning Arrestor Connector component, a critical safety device for one of Sandia's weapon systems.

Designers, manufacturers, and vendors now understand their contributions to and responsibilities for safety, and it has created an auditable, pedigree trail to review all agreed-upon requirements. Additionally, as trade-offs are negotiated internally and lessons learned are captured, this data is archived and electronically accessible for future reference.

## PROTOTYPE DEVELOPMENT AND REVIEW

### Integrating Rapid Prototyping and Computer Simulation into Investment Casting

SNL's Integrating Rapid Prototyping Laboratory uses commercial stereolithography and selective laser sintering to quickly respond to the needs of its customers. Recent advances in stereolithography and selective laser sintering have had a significant impact on the overall quality of parts produced using these rapid prototyping processes.

The implementation of the QuickCast™ epoxy resin and software has made it possible to accurately build semi-hollow honeycomb patterns for investment casting. With this resin base style pattern, the problem of thermal expansion during burn-out is minimized, and the patterns can collapse inward rather than expanding outward and fracturing the ceramic shell.

In the Rapid Prototyping Laboratory, stereolithography and selective laser sintering systems are supported by expertise in ProEngineer from which thin slices (cross sections) of the CAD solid model are sent to the systems and solidified layer by layer. This creates an inexpensive, detailed, and accurate conceptual model that is a useful tool for visualization purposes, and it can be handled. The labs use these

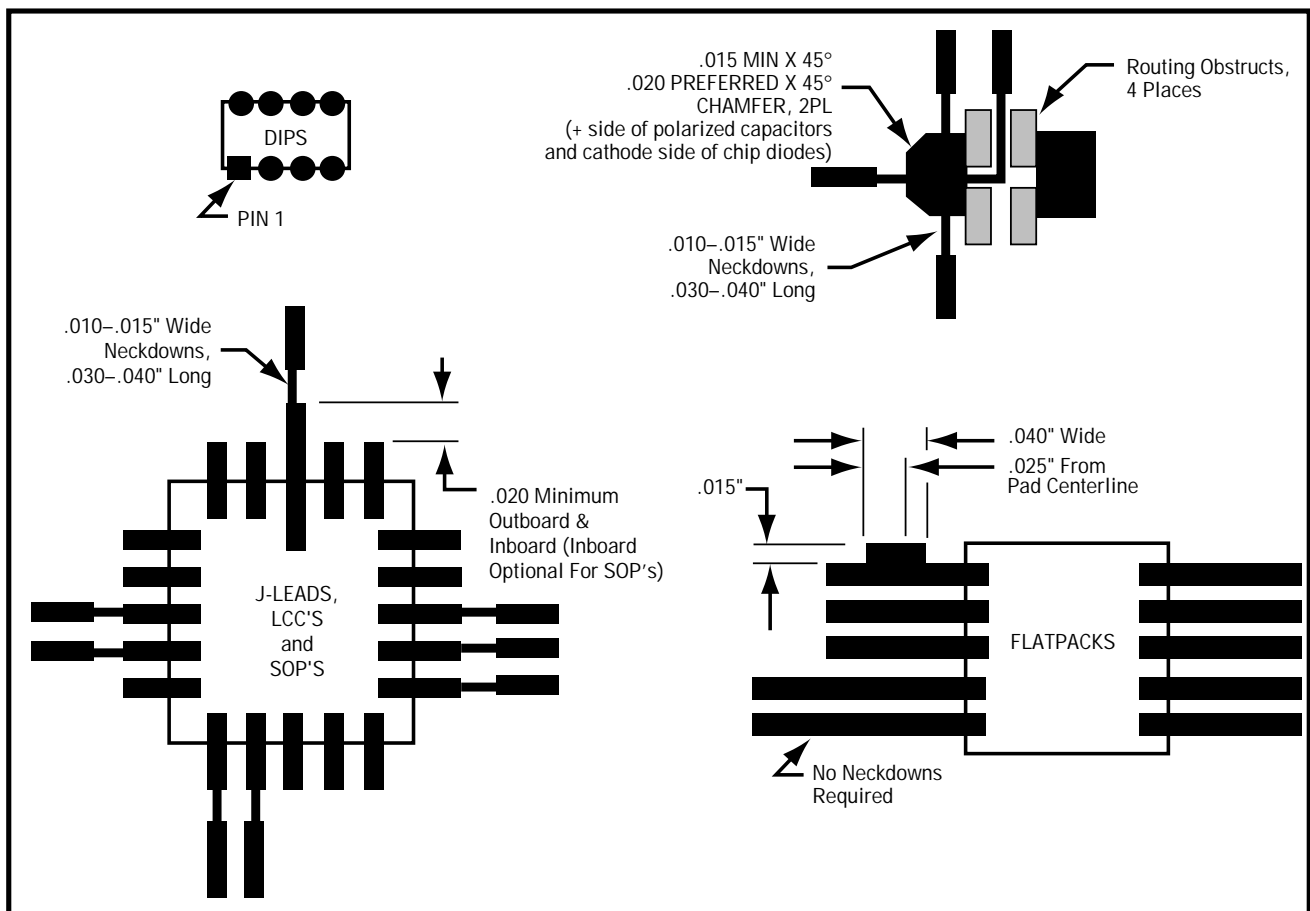

**FIGURE 2-7. COMPONENT FOOTPRINT ETCHED ORIENTATION FEATURES**

models as part of bid packages, verification, and for checking form, fit, and function.

The development and implementation of the Rapid Prototyping and Computer Simulation for Investment Casting comprise Sandia's complete in-house, design-to-cast capabilities which have reduced time for pattern production when coupled with solid model designs. Small lot production parts are easily attainable without fabricating costly hard tooling.

### Prototype Electronics Facility

To reduce cycle times and improve product quality, prototypes play an increasingly critical role in product development at Sandia. Consequently, the SNL developed an integrated approach to prototype development at their Electronic Prototype Laboratory. This lab provides SNL with a total prototyping capability where customers can bring CAD data on a floppy disk and obtain prototypes ranging from PWBs to complete assemblies.

Capabilities at the Electronic Prototype Lab include artwork generation, PWB fabrication (single-sided,

double-sided, and multilayer up to 16 layers), bare board test, through-hole and SMT attach, autodrill and autoroute, lead form, and more. In addition, the lab has published a book listing the components that are stocked as well as accepted component footprints (Figure 2-7). Designers can use this information to facilitate the prototype process and to assist them with component selection. The prototype lab also offers customers different levels of prototype printed wiring boards such as Type A, available in a few days' time, doubled-sided with plated through-holes (but little or no checking or testing); and Type B which is available in a few hours, double-sided with no plated through-holes and no testing. This tailoring allows designing to "quick and dirty" prototype with very little time investment.

The Electronic Prototyping Lab has become an integral part of many of SNL's projects. Benefits include a reduction in cycle time afforded by placing working products in the designer's hands as quickly as possible, as well as allowing for expeditious proof of concept activity. This Electronics Prototype Laboratory is a valuable asset to the entire concurrent engineering philosophy.

## 2.2 TEST

### INTEGRATED TEST

#### Quiescent Power Supply Current Testing

Sandia National Laboratories and the University of New Mexico have developed a test circuit based on the Keating-Meyer method to measure quiescent power supply current ( $I_{DDQ}$ ) (Figure 2-8). This test circuit is a faster and more precise test circuit than those used in commercially available testers.  $I_{DDQ}$  testing greatly reduces the number of test patterns and increases detection of fabrication defects of complementary metal-oxide semiconductor (CMOS) microelectronic circuits compared to traditional functional or stuck-at-fault testing.

Traditional automated test equipment has not been designed to accurately measure current at high test speeds. The few manufacturers that have this capability have faced tradeoffs in trying to measure current with both speed and accuracy.

Efficient fault detection of integrated circuits at their functional outputs has become difficult because of increased complexity and gate count. Traditional testing assumes stuck-at-faults that oversimplify the behavior of defects of CMOS integrated circuits. Boundary and full scan circuits have been added to component designs to help improve fault coverage above 95%, but low quality and reliability have persisted.  $I_{DDQ}$  is the current required to power the CMOS integrated circuit after all logic transitions are made. In present CMOS integrated circuits, the magnitude of  $I_{DDQ}$  is

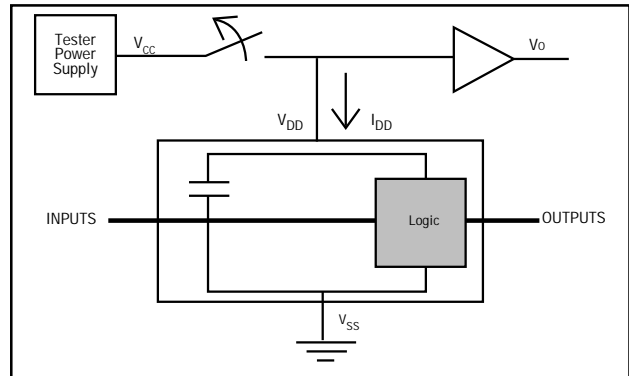

**FIGURE 2-8. KEATING-MEYER  $I_{DDQ}$  CIRCUIT**

commonly less than 1 nA. However, when there is a defect such as a gate-to-source short (Figure 2-9), the quiescent current is one or more orders of magnitude higher. CMOS integrated circuits have complementary pairs of p-channel and n-channel transistor networks, with one pair on and the other off in the quiescent state. This allows one vector to test about 50% of the transistors. As the number of test patterns is increased, fault coverage increases rapidly. The number of test patterns for  $I_{DDQ}$  testing has been proven to be orders of magnitude less than the number of patterns for stuck-at faults.

$I_{DDQ}$  testing technology has been transferred to industry through technical papers, tutorials, and presentations at test conferences.  $I_{DDQ}$  testing has led to increased detection of common defects with smaller test patterns. Industry results have shown a 10- to 100-fold quality improvement by implementing  $I_{DDQ}$  testing.

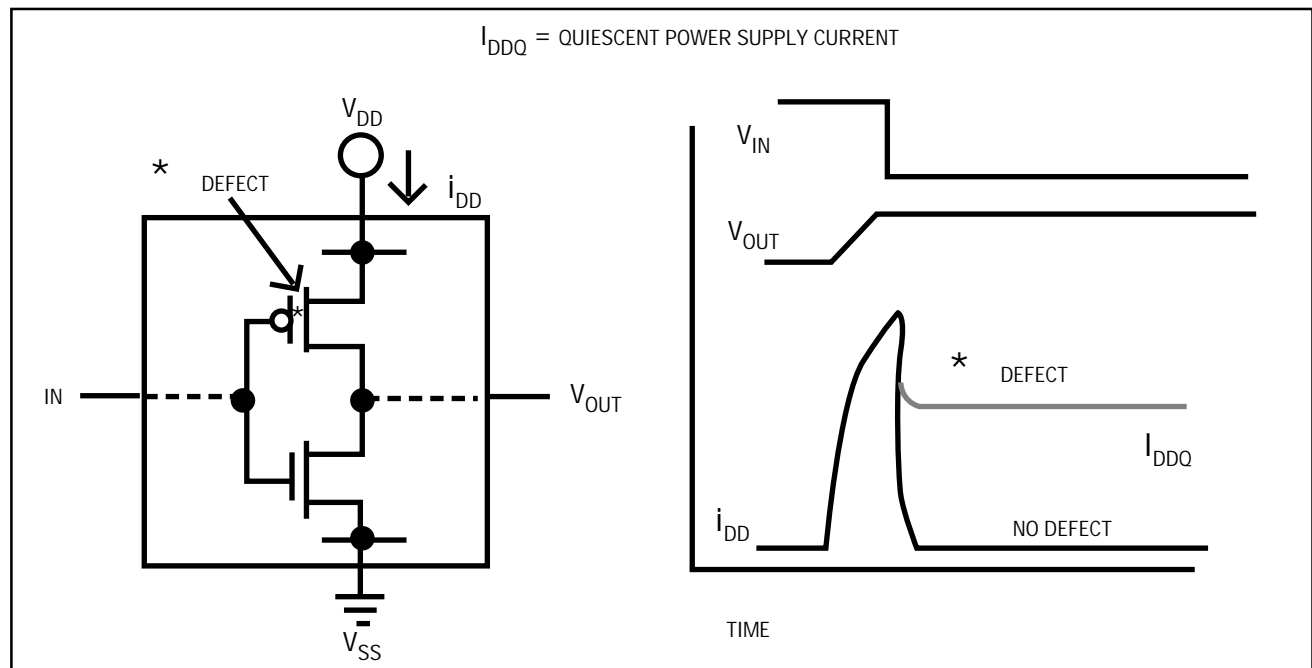

**FIGURE 2-9.  $I_{DDQ}$  TESTING**

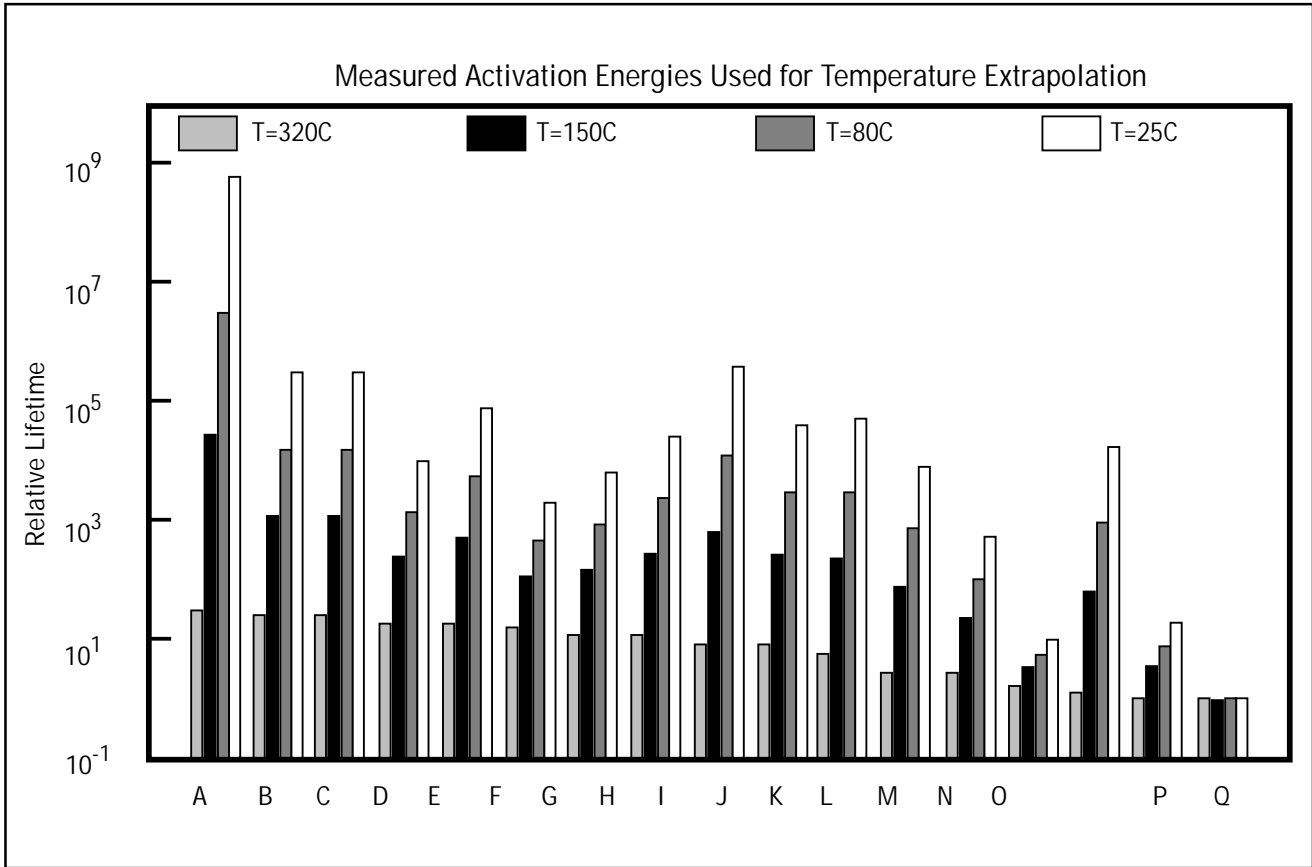

**FIGURE 2-10. RELATIVE ELECTROMIGRATION LIFETIMES OF ICs BY MANUFACTURERS**

**Microelectronics Reliability Benchmarking Facility**

The SNL Microelectronics Reliability Benchmarking Facility independently tests commercial manufacturers’ integrated circuits to benchmark reliability. The Reliability Physics Department has developed a standard set of tests for the most common failure mechanisms of integrated circuits. By testing samples from throughout industry, manufacturers can benchmark their products against their competitors’ products.

Reliability requirements of integrated circuits had been verified by their customers. However, when consumers expectations were not met, customers would go elsewhere, commonly without the manufacturer’s knowledge. Manufacturers would not know what other competitors’ reliability was in comparison unless they did continuous reliability testing of the industry. To address this issue, Sandia generated standard software, Sandia Wafer-level sOftware for Reliable Devices (SWORD), to test electromigration, oxide breakdown, and hot carrier degradation. Manufacturers can now construct a standard set of circuits on each wafer called test structures. A self-stressing test structure, Self-stressing High-frequency Reliability Devices (SHIELD), enables San-

dia to control the temperature and frequency while SWORD performs the reliability tests. Wafer probers are used to test three-inch to eight-inch wafers at temperatures from -55 to 400°C and frequencies up to 500MHz with SHIELD.

The key to the successful benchmarking process has been obtained through keeping the reliability testing results confidential. Only the manufacturer’s results as compared to the rest of industry are released (Figure 2-10). Most U.S. semiconductor manufacturers and some foreign manufacturers have participated. Benchmarking reliability has been both beneficial to the U.S. Government and industry. Areas for internal improvement are clearly defined to industry, while the government gains the knowledge of industry’s reliability capabilities.

**FAILURE REPORTING SYSTEM**

*Integrated Circuit Failure Analysis Expert System*

Failure Analysis engineers at Sandia National Laboratories have developed a system to train novice integrated circuit failure analysts without the live mentoring of an experienced analyst. The training tool is an artificial intelligence program

called Integrated Circuit Failure Analysis Expert System (ICFAX). Fault analysis of an electronic integrated circuit usually involves disassembly or cutting the device open to look for the physical phenomena that caused the circuit to malfunction. Because the device inside the package is so small, analysis is a very intricate process involving microsurgery and electron microscopes. The process normally requires about five years for an analyst to acquire proficiency at failure analysis and once trained, the analyst is frequently worked to a point where training for other personnel is limited.

ICFAX uses an inference engine to provide interactive reasoning capability and a hypertext help engine to provide supporting text, graphics, and photographs to the user. Almost 100 manyears of expert experience are captured and anticipated in 83 program modules and 8500 rules. In addition to training novice analysts, the system is used as a repository for expert knowledge, allowing experienced users to quickly locate failure analysis information and store useful techniques and information for future analysis.

The system works in a Windows environment on both UNIX and DOS workstations. The program iteratively

walks the user through a fault tree, asking questions and displaying graphics and high resolution photographs on the screen (Figure 2-11) to help with each decision. The database contains over 700 pages of help text and 200 megabytes of image data to guide the user through the process.

## 2.3 PRODUCTION

### MANUFACTURING PLAN

#### *Agile Manufacturing Facility for Integrated Circuits*

Sandia's Microelectronics Development Laboratory provides a model of agility, reconfigurability, and robustness in its IC fabrication cleanroom facility. Modern integrated-circuit fabrication facilities arrange clean rooms around the work flow for a particular technology. These clean rooms have to be reconfigured to accommodate newer technologies. Of greater concern, once one part of the clean room becomes contaminated, the entire facility becomes non-functional, leading to lost work-in-process

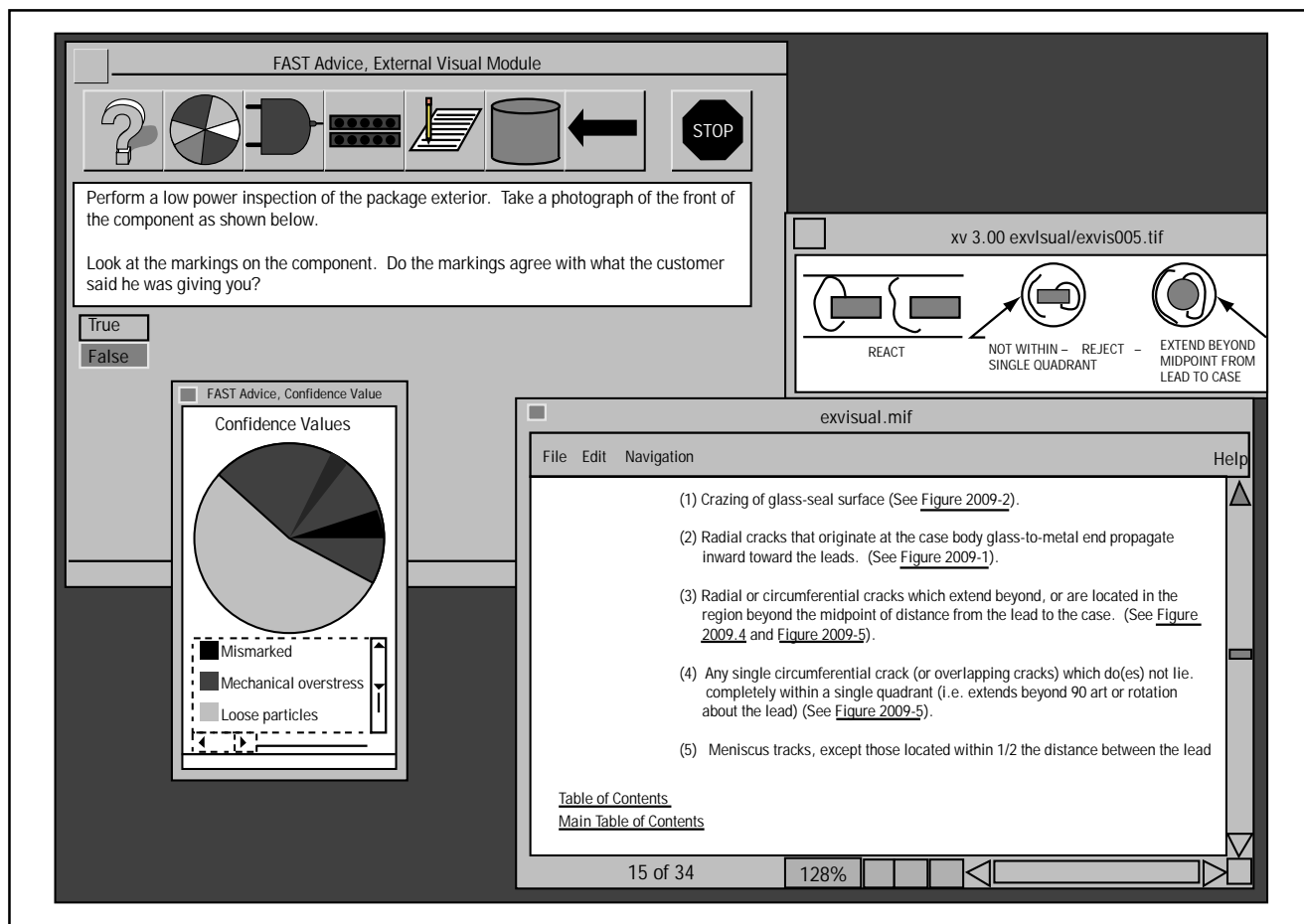

**FIGURE 2-11. ICFAX USER DISPLAY**

---

and costly downtime, and clean room operators are averse to risking productivity improvements through new equipment or processes.

The SNL maintains a 33,000 square foot, Class 1 clean room configured into 22 independent air supplied bays. Each bay is isolated from the rest of the facility, allowing the development of highly speculative, potentially contaminating technologies. This arrangement also allows for concurrent prototyping and small lot quantity manufacture of ICs of differing technologies. Experience has shown that bays can be recovered from contamination within hours after exposure.

This agile prototyping capability allows the Sandia Microelectronics Development Laboratory to investigate promising research done by universities, government, and industry and transform the research and development breakthroughs into practical products that will have useful impacts. The SNL evaluate this research and development effort against need, impact, cost, and risk and determines if it is a viable venture to undertake. If the venture seems workable, a team of personnel is assembled to undertake the project. The goals and priorities are clearly communicated to the team members. Manufacturing processes are developed and metrics established to track the daily progress of the project.

With the facilities, equipment, and personnel available at the Microelectronics Development Laboratory, the SNL can rapidly transform leading-edge research into practical prototypes and products. The facility focuses on the development of complex “systems-on-a-chip” through integration of microelectronics, micromechanics, and sensor technologies. This facility has well-defined manufacturing practices which ensure rapid and effective prototype development.

## **QUALIFY MANUFACTURING PROCESS**

### **Machine and Process Characterization**

Sandia applies machine and process characterization to define and qualify a process window and parameter space. This allows SNL to quickly produce a product in an agile environment, with the assurance that the necessary quality is present since the product is a subset of the parts and processes that have already been qualified and characterized. To implement agile manufacturing, customer requirements must be quickly translated into designs, then produced or procured, and assembled. In addition, advance knowledge of part types, features, and tolerances are required to develop a parameter space, as well as what machines, tools, and machine settings are likely to be needed to produce the required parts.

There are advantages to defining a parameter space. When parameters are specified on a continuous basis, it is not possible to test and qualify every point within the

parameter space; however, by using design of experiments, every point within the parameters can be qualified by testing only certain points. Sandia identifies this parameter space and particular points within that space as a parent-child relationship. The qualification attributes of a parent design are selected for design, fabrication, assembly, and acceptance processes, and the parameter space is defined. The attributes “capable” and “controlled” for fabrication and assembly processes require the collection of data in characterization studies. When characterizing processes, it is important to explain observed phenomena, predict process behavior, control the process, and optimize the process throughout the parameter space.

To verify process characterization techniques, Sandia has implemented machine and process characterization within the A-PRIMED program, an agile product realization of innovative electromechanical devices. Design of experiments was used to verify that the chosen process window or parameter space was capable of producing qualified products throughout the parameter space.

The machine and process characterization for parameter space qualification presents a systematic approach for qualification of high quality parts and processes. This system uses engineering analysis and statistical design of experiments to qualify the parameter space and any individual point within it. This enhances agility by qualifying a family of designs and flexible processes before production.

## **SUBCONTRACTOR CONTROL**

### **Manufacturing Liaison Supplier Performance System**

Sandia National Laboratories recognized a need for a technical organization to assist the designer and buyer for successful acquisition of needed components. In October 1985, Sandia established the Manufacturing Liaison Department (MLD) to provide technical support for the overflow build-to-print work. As this department evolved, a supplier database was established which has enabled SNL to identify over 3000 contractors’ capabilities and performance.

Sandia National Laboratories Contracting Representatives previously have made source selections based on individual research, inputs, and recommendations. For example, some suppliers were recommended because they had been previous suppliers, not based on a needed capability. There was no verifiable supplier performance information available which could indicate the possibility of delayed work or poor product quality. If a supplier had a technical question, the requester was not always available, or they may not have had an answer for a producibility problem. A consolidation of information was needed to ensure all Sandians had equal access to current supplier information and services.

---

The MLD provides SNL with a central source of information and capabilities on more than 3000 suppliers. The department includes electronic technicians, journeyman machinists, and a mechanical measurement technician. The group resolves technical questions that might arise during design or fabrication. It conducts drawing reviews, supplier surveys, technology exchange, and electronic data transfer. With the use of a Supplier Rating System, the group can make sound recommendations to the integrated purchasing group. A Geometric Dimensioning and Tolerancing class is also offered and provided free to small businesses.

The MLD has developed a Supplier Performance System that is based on the contractor database. A method was developed to identify a supplier's current capabilities and performance. Each month a contractor receives a Supplier Rating System Report which provides the status of deliveries, quality performance, and a composite rating. Continuous monitoring of constantly changing supplier capabilities is provided by MLD, and the information is fed into the database. MLD has supported 1719 contracts with 3871 bidding opportunities to 389 different manufacturing facilities during 1993.

This effort has resulted in several benefits. For example, MLD played an integral role in the purchase of 2,500 H-1616 shipping containers which are used for the shipment of reservoirs containing Tritium. There were a total of 13 suppliers of components. This program came in under cost and schedule. Also, the Sandia's MLD and purchasing team underwent ASME/NQA-1 audits and did not have any findings. SNL won the Eisenhower Award in 1993.

By establishing a Manufacturing Liaison Department and developing a Supplier Performance System, Sandia is helping team knowledgeable technical people and purchasing people to ensure the success of product and supplier. This critical information is used to match the requester's requirements with supplier's capabilities to guarantee a program's success.

## **SPECIAL TEST EQUIPMENT**

### **Techniques for Aging Aircraft Inspection**

The FAA created an Aging Aircraft Non-destructive Inspection Validation Center (AANC), managed by Sandia, to address aerospace industry needs for its aging civilian fleet. The AANC's primary mission is to assist in the development and transfer of emerging non-destructive inspection technologies from universities, government, and private industry to the aircraft industry. To support this objective, the AANC has developed a validation process that can be used to determine the reliability and cost effectiveness of a candidate inspection technology.

The validation process consists of four phases—conceptual, preliminary design, final design, and field implementation. Phase 1 validation activities include identification of the problem and requirements, determination of the approach, laboratory demonstration of proof-of-concept, and initial estimate of equipment costs. Phase 2 activities focus on laboratory tests of initial prototypes and determination of operator procedures and inspector requirements. Phase 3 provides an assessment of factors affecting reliability through demonstrations of capability on "blind" test specimens in the laboratory and in the field. Phase 4 involves developing fieldable prototypes, finalization of procedures, field trials with independent inspectors and potential users, and full cost/benefit analysis. The results of these new inspection techniques are then released to the aircraft industry and the FAA and if adopted, become standard or alternate inspection procedures to follow during maintenance inspection of aircraft.

To date, the AANC has demonstrated excellent results. One of the first investigations resulted in a consumer report on Ultrasonic and Eddy Current Scanners which are used to inspect riveted joints in the aircraft skin. The second success was the validation of a Magneto-Optic Imager (eddy current) which was able to scan a six-inch by six-inch area of skin without removing surface paint, as opposed to eddy current point scanning techniques. Thirdly, AANC has validated an inspection process to inspect the wingbox (structural member of airframe where wing meets fuselage) utilizing non-invasive ultrasonic testing techniques. Sandia is also working on alternative testing processes for halon fire extinguisher bottles using acoustic sensing technologies to determine and certify pressure vessel integrity.

## **PIECE PART CONTROL**

### **Hierarchical Qualification of Electrical Components**

The SNL have developed a new component selection and evaluation plan to produce a telemetry processor of the highest quality. The plan was customized by the product realization team who determined the requirements of that particular product. Under the old method, component vendors were audited and rated by a team from SNL before components could be provided by that vendor. This process was costly and time consuming. In addition, each component was qualified by additional rigorous in-house testing to SNL specifications. Every part went through this process, thereby significantly increasing the cost.

The most important feature of the new plan was a hierarchical method of selecting components. The team selected corporate preferred parts when possible but used other



---

components when it was determined that the overall quality of the system would improve. By applying this method, information about part quality from all sources could be given to the electronics designer at the time of part selection. This was the most significant advantage of the plan, since electrical component quality was the major cost driver for electronic product quality.

Under the new plan, acceptance testing has been reduced 90%. The cost of individual components has dropped 75%, and the time required to obtain new components has also been reduced significantly. By using quality components up front, the cost of the assembled telemetry processor has been reduced while its quality has increased. SNL has set the stage to apply this procedure on other products and expects widespread use throughout the company.

## ENVIRONMENTAL ISSUES

### Environment, Safety, and Health Regulatory Compliance Support for Suppliers

Sandia has developed a database/knowledge-based system to perform environment, safety, and health (ES&H) regulatory compliance assessments of manufacturing processes. It is part of Sandia's aggressive, proactive approach to managing the exposure to risk and liability resulting from supplier ES&H regulatory compliance deficiencies, particularly in hazardous waste management and disposal. The process investigates, identifies, and communicates all known or suspected hazards related to contracted activities. It also identifies ES&H technical assistance or other intervention strategies that result in win-win solutions for Sandia and its suppliers.

Prior to initiating this process, no mechanism was in place to address potential liability resulting from ES&H regulatory compliance deficiencies of suppliers. Other companies used audits to manage this problem, but Sandia wanted to find an alternative to the adversarial nature of audits and manage exposure to liability in a positive and productive way. The process was also developed as a way to manage the risk of cost or schedule overruns due to regulatory compliance issues.

First, a process assessment methodology was developed, applied to contract specifications, and made available to suppliers. A database was established to link manufacturing processes and materials with regulatory issues. The database was enhanced to incorporate solutions to compliance issues including compliance program templates, environmentally conscious manufacturing technologies, pollution prevention and waste minimization, and federal, state, and local resources. The database was called Interactive Technology Distribution System (ITDS). A front end smart questionnaire called Materials and Process Characterization

(MPC) questionnaire was developed and interfaced with the database using a commercially available software package called Exsys<sup>®</sup>. The result was an expert database/knowledge-based system called ITDS/MPC.

ITDS/MPC, which differs from commercially available regulatory databases in several ways, is ideal for aiding small businesses. It is designed for users not familiar with ES&H regulatory compliance issues. Users need not have any knowledge of regulations because regulatory issues are linked to materials and processes. Hazard determinations are made for the user based on regulatory criteria. Going from materials and processes to regulatory compliance issues frequently requires some professional judgement and interpretation. This expertise is contained in the knowledge-base of the MPC. ITDS/MPC teaches the user about regulatory compliance issues. MPC may also be used to model changes in regulatory compliance issues with changes or additions of new materials and processes.

ITDS/MPC is a tool to assist the user in determining compliance requirements, prioritizing those issues, and solving compliance problems. It is also a training tool that is most useful to organizations without access to EH&S professionals.

The ITDS is built on a commercially available database platform Paradox<sup>®</sup> for Windows which operates in a DOS/Windows environment and may be networked. The MPC is built on a commercially available expert system shell Exsys<sup>®</sup> supporting both DOS/Windows and Macintosh operating systems. Minimum hardware requirements are IBM PC (or compatible), 4 MB RAM, 80 MB hard disk space.

Application of this process and the use of automated tools have helped Sandia improve relationships with its suppliers, especially the small industrial manufacturers. The system identifies potential regulatory issues early, particularly those which vary from state to state, and avoids liability risks. It identifies cost effective solutions to regulatory problems and uses technology transfer to solve potential compliance problems.

### Low-Residue, No-Clean Soldering Process

In July 1991, Sandia National Laboratories entered into a joint program with Motorola's Government Electronics Group and Los Alamos National Laboratory to evaluate a no-clean soldering process acceptable for DOD applications. The no-clean process studied incorporates a dilute adipic acid flux which is ultrasonically sprayed on the PWBs to remove oxidized material before soldering. The adipic acid evaporates or is consumed in the soldering process. To inhibit oxidation of the PWBs during the soldering process, the wave solder chamber is filled with a nitrogen cover blanket. A formic acid vapor is bubbled into the nitrogen as

---

an oxygen “getter” to further reduce oxide formation in the soldering zone. The formic acid then decomposes in the heat of the soldering process to carbon dioxide and water. The net result is a clean, soldered PWB when it leaves the wave soldering machine.

Since military specifications and standards did not allow the use of adipic acid as a fluxing material and mandated that all PWBs be cleaned after soldering, the second step of the program was to qualify the new process for military applications. Sample PWBs were manufactured and tested for visual defects, ionic cleanliness, surface insulation resistance, temperature cycle, temperature-humidity, long-term storage, joint (electrical), joint (mechanical strength), and surface chemical analysis. The tests concluded that the visual solder joint quality, PWB reliability, and product shelf life were unchanged by the new process. Minimal residues were detected on the PWBs, but had no impact on performance or reliability. As a result of the testing, two major defense contractors have sought and were granted 69 deviations to military standards to use the process for their military products. One long-term goal of the program is to change the military standards and specifications to accept this process.

Low-residue soldering technology is proving to be less expensive than the conventional rosin or soluble flux process. Motorola has noticed an order of magnitude decrease in wave soldering machine preventive maintenance. IBM Canada has reported a savings of \$752K per year over rosin flux/solvent cleaning processes and \$590K per year savings over water soluble flux and aqueous cleaning processes.

## **2.4 FACILITIES**

### **MODERNIZATION**

#### **Concurrent Engineering Communications**

In June 1993, Sandia National Laboratories began a project to develop and demonstrate a process to rapidly transition designs of precision electromechanical devices into production. Titled Agile Product Realization of Innovative ElectroMechanical Devices, or A-PRIMED, the project had many problems to solve, none more significant than the isolation of the core team members assembled for the project from one another. Because of their widely varying disciplines, tools, and facilities, collocation was impractical. The 16 initial members were located in nine different buildings, and the team would eventually grow to include members not even in the same state.

It was obvious that Agile Product realization would require a communication infrastructure that would enable rapid and seamless exchange of information between members of the project team. Solving this problem would eventu-

ally lead the team, under the guidance of a Human Factors expert, to create a communication system that completely supported concurrent engineering of the products.

The team developed an electronic mail infrastructure for communication. There had been little cultural history of cross-organizational collaboration; therefore, the next step was to learn what information and data each discipline used and produced, where it came from and went, and what platforms the information was on. The team created a communication network that would allow it to manage and share all data. Although networking data is not a new concept, this communication system allowed the information and design data to be shared by the different platforms owned by the various organizations on the team. True concurrent engineering could not occur without this feature. A-PRIMED contributed to the concurrent engineering process development and improvement by its attention to organizational aspects of communication within the product development team, the role of information in the product development process, and human factors impacting the introduction and acceptance of new processes.

#### **Department of Energy Primary Standards Laboratory Facility**

The mission of Sandia’s Metrology Division PSL is to maintain and certify primary measurement standards for the DOE nuclear weapons complex; to continually assess the complex to ensure integrity of measurements through site specific technical surveys and audits; and to develop new standards.

Housed in a new, state-of-the-art, \$18M, 30,000-square foot facility equipped with environmental control (temperature and humidity), electromagnetic radiation shielding and vibration control, the PSL is dedicated to metrology activities that provide support for several metrology disciplines. Through the use of technical professional staff and a multi-million dollar investment in equipment, the PSL provides technical guidance, support and consultation; develops precision measurement techniques; provides oversight for calibration recalls of metrology standards used within the complex; performs technical surveys and measurement audits; and anticipates future metrology needs of the nuclear weapons complex.

Working closely with the Department of Commerce’s National Institute of Standards and Technology (NIST), the PSL is pursuing laboratory accreditation that will provide a key resource to the National Voluntary Laboratory Accreditation Program which promotes national accreditation of academic and industrial laboratories which may become a competitive advantage in world markets.

---

## PRODUCTIVITY CENTER

### Facilities Accelerated System Team

SNL created the Facilities Accelerated System Team (FAST) program in 1992 to provide rapid support for production and manufacturing operations. Prior to this time, SNL performed all facilities construction, equipment installation, and facilities engineering on a first-come, first-served basis. This process resulted in many missed deadlines, cost overruns, and dissatisfied customers. In many cases, new equipment would remain on the dock or in a staging area for long periods of time, resulting in implementation delay of new production processes. To alter this unacceptable process, a new system was initiated to ensure equipment installations, as well as new construction, would be completed on time and within budget.

A Contract Project Manager (CPM) is now assigned to each major customer. This CPM maintains a cradle-to-grave responsibility for project completion to the customer's satisfaction. When a new project is initiated, the CPM meets with the customer and becomes involved with any up-front planning. Negotiated design and construction commitments are obtained between the customer and the CPM, giving each party a clear understanding of what is required and when.

The CPM then assembles a FAST group comprised of appropriate personnel to accomplish the required work. Team membership consists of contract personnel, engineers, facilities specialists, maintenance personnel, and any other personnel required to accomplish the completion of the project. With the team in place, the CPM or his representative meets with the equipment manufacturer to gain a complete understanding of the new equipment and its needs. This continuing dialogue with the manufacturer allows the CPM to keep abreast of changing equipment needs and provide for them in the installation/construction process.

The single point accountability and continuing dialogue with the customer and equipment manufacturer helps to ensure completion of the project on time and within budget. Metrics are in place to measure all significant milestones and are regularly reviewed by both the customer and the CPM. Any changes in the scope of the work are identified and new costs/schedules are agreed upon by the customer and the CPM. This process has resulted in significant decreases in total project costs, shortened project cycle time, and has allowed new equipment installations to be accomplished in as little as five days after receipt of the equipment. The degree of customer satisfaction with the facilities department has also increased significantly.

## FIELD VISIT / SITE SURVEYS

### Technical Surveys for Standards Laboratories

Sandia's PSL is responsible for ensuring that all calibration and certifications performed at DOE weapons laboratories conform to standards requirements for traceability. To achieve this objective, PSL developed a formal process to monitor and control the continued assessment of the complex. A key factor in the execution of this strategy is the periodic visits to each of the DOE laboratories with a team of metrologists to provide an in-depth technical review (audit) of all of the laboratories' calibration activities. Traditionally, the team reviews uncertainty analysis, accuracy capability, traceability to national standards, training of metrologists, software maintenance, standard recall activities, and management of the calibration process.

To date, the PSL has maintained a successful record of maintaining the calibration of more than 5000 standards used in over 12 separate DOE facilities across the United States. Through the use of technical surveys, PSL has found that the audits provide an excellent measure of the standards laboratory's actual capabilities and provides for valuable exchange of technical information which occurs between the survey team and customers.

## 2.5 LOGISTICS

### SUPPORT AND TEST EQUIPMENT

#### Non-destructive Evaluation Capabilities for Process Monitoring

Sandia's Testing Support Center performs a unique service at the labs with several objectives. These objectives include analyzing production/processes and related inspection techniques; introducing non-destructive evaluation (NDE) inspection technologies; and validating inspection processes where there are opportunities to improve the product quality through a variety of NDE technologies.

With a team of professional engineers, the Testing Support Center maintains a wide assortment of NDE capabilities to perform both laboratory and field evaluations. Radiography (to 10MeV), ultrasonic scanning (to 1 GHz), computer tomography (to 2.5 MeV), acoustic monitoring, coherent optics, and enhanced visual (high speed and ultra-high speed photography) are all part of those NDE capabilities. Examples of this successful application are illustrated by improvements to manufacturing an Atomic Force Sensor through the use of acoustic microscopy; Integrated Circuit inspection through ultrasonic inspection; automated and manual paint thickness inspection applying ultrasonic and

eddy current techniques; acoustic bearing analysis; and circuit board inspection using computer-aided tomography.

These capabilities have been successfully integrated into product development and the production data stream to improve product quality through process improvements.

## TRAINING MATERIALS AND EQUIPMENT

### Instructional Video

Facing the reality of lower production requirements, SNL implemented an instructional video program to capture specific operations and skills in many manufacturing applications. Sandia realized that if the information captured could be included in an on-line manufacturing system, it could maintain a competitive edge. In the past, training included two people (trainer/trainee) away from work. If bad habits were taught, then bad habits were propagated, resulting in skilled operators not always being available to train when needed.

Improvement was required to address agile manufacturing, multi-task proficiency (at all levels), maintenance of broad-based skills, and development of expert training tools used in the relocation of manufacturing processes. To accomplish this, changes were implemented using Sandia's professional videographers to shoot the videotape and edit the final product. Several different videos have captured the art of performing specific operations and are available for operators in a video library. The tapes range from three to seven minutes depending on the application involved.

The processes and the time involved in production include:

Operation	Time	Total Man Hrs
Videotape Manufacturing Operation	2 hours	Up to 8
Review of Video	1 hour	Up to 3
Edit, Script, and Narrate	4 hours	Up to 12

Sandia National Laboratories share benefits from the new training model. Quality is enhanced and inspection reduced as each worker can compare results of their work to the video record. "Real-time" training is now available on demand. Consistent training for all operators reduces process variability. Language barriers are minimized by using instructors fluent in English. The instructional videos provide a permanent, complete visual record for quality assessment. Intricate, complex operations are now easily understood. The instructional video program was instrumental in en-

hancing worker and environmental safety through improved communications at Sandia National Laboratories.

## 2.6 MANAGEMENT

### MANUFACTURING STRATEGY

#### Small Business Initiative

As a world class leader in hundreds of scientific and technological fields, Sandia provides a national resource for transferring technology to small business. Along with DOE's other national labs and two production agencies, over \$9M is allocated annually to provide technical assistance and other services to small business. This initiative is designed to provide technical referrals and assistance in a timely and efficient manner. Sandia maintains excellence and high standards by focusing assistance only in its core competencies. Needs falling outside core competency areas are referred to other Department of Energy facilities and federal programs.

The small business initiative at Sandia is a relatively new and small program but has produced impressive results. Table 2-1 shows the number of cases and types of assistance provided in FY94 and projected for FY95. Several types of technology transfer mechanisms are used. These include technical assistance, partnership agreements, user facilities, relationships with intermediaries, and personnel exchange and range in value from \$5K to \$50K. All funds for this program are expended internally. There is no direct financial assistance to client companies. The program is national in scope and has provided assistance to small businesses throughout the country. Technical assistance has been provided to small firms in materials and processes, electronics testing, energy and environment, nuclear security, systems reliability, and systems engineering. Nearly 35 CRADAs have been executed in fields of manufacturing, microelectronics, materials, computing, and energy and environment. User facilities were made more accessible to

**TABLE 2-1. TECHNOLOGY TRANSFER TO SMALL BUSINESS**

	FY94	Women & Minority	Program to Date Total	Women & Minority	Projected FY95
Technical Assistance	276	32%	514	24%	300
CRADA (Non-SBI funded)*	10	0%	41	5%	10
CRADA (SBI funded)*	30	10%	44	10%	26
User Facility Agreements	3	0%	3	0%	35
Commercial Licenses	9	11%	27	11%	18
Intermediary Agreements	10	n.a.	10	n.a.	10

\*SBI - Small-Business Initiative

small businesses by eliminating many of the high security requirements that were in place. Sandia is making its facilities more accessible, such as the following:

- Combustion Research Facility
- National Solar Thermal Test Facility and Design Assistance Center
- Electronics Quality/Reliability Center
- LAZAP-Laser Applications
- NUFAC- Nuclear Facilities Resource Center
- Explosives Components Facility
- Robotics Research and Training Center
- TIE-IN Scientific and Engineering Computing Center
- Materials and Process Diagnostics Facility
- Ion Seam Materials Research Lab
- Primary Standards Laboratory
- Shock Technology and Applied Research Facility (STAR)
- Component Modeling and Characterization Laboratory
- Mechanical Test and Evaluation Facility
- Design, Evaluation and Test Technology Facility

In its short implementation period, this initiative produced many success stories. Sandia helped one small business to engineer a non-invasive optical technology that makes cervical cancer diagnosis easier and quicker. A small, woman-owned business was assisted in developing a mobile, environmentally-safe agricultural growth chamber that greatly reduced costs and increased production for farmers, cattle producers, and health food suppliers. It is being made available to third world countries needing food production technology. On average, two new jobs and \$67K of economic impact value resulted from each technical assistance case in FY94.

### Small Business Programs

Sandia is very active in the award of contracts to Small Business, Small Disadvantaged Business, and Woman Owned Business firms. Table 2-2 describes the FY94 awarded contracts showing percentages of commercial procurement:

**TABLE 2-2. FY94 AWARDED CONTRACTS AND COMMERCIAL PERCENTAGES**

Amount of Awards	(FY94)	% Commercial Procurement
Procurement		
Small Business	\$435,093,758	49.6%
Small Disadvantaged	\$ 87,446,519	10.0%
Woman Owned	\$ 65,912,485	7.5%

An extensive outreach program has been established to identify qualified or qualifiable companies in these categories and to assimilate them into Sandia's supplier base. The procurement center is developing a supplier quality database to record and track metrics for price, delivery and product quality and service of each vendor. The outreach program identifies 20 to 26 Trade Fairs and networking activities per year to provide an opportunity for suppliers to meet buyers. Interviews are conducted with all new potential subcontractors who visit Sandia, and introductions are given for technical and buyer contacts. In addition, Sandia conducts six to eight business educational programs with assistance from the local Chamber of Commerce, economic development organizations and other community participants within the year. For example, Sandia awards scholarships to small businesses to attend two-day seminars at the Quality Conference. These conferences are jointly sponsored by Sandia and New Mexico State University. Each conference features well-known industry and academic speakers. Sandia mentors small businesses and offers assistance in Total Quality Management, Proposal Preparation, and Just-In Time Procurement Techniques at minimal fees.

In FY95, Sandia will be implementing a small business set-aside program which will include specific set-aside programs for small disadvantaged businesses, woman owned businesses, and businesses that have been certified under section 8(a) of the Small Business Act. They have established challenging goals for purchasing from these groups as well as Center goals to exceed DOE's contract requirements on the Martin Marietta contract. Figure 2-12 shows the dollar value of socioeconomic procurement activity over the past few years. The challenges in the near term include developing and implementing funding for mentor/protege programs and improving means of communication with all groups. Sandia serves on the Board of Directors of community business development organizations to increase awareness and show their commitments to the success of the program.

Sandia National Laboratories have earned recognition for outstanding contributions to small business. Awards

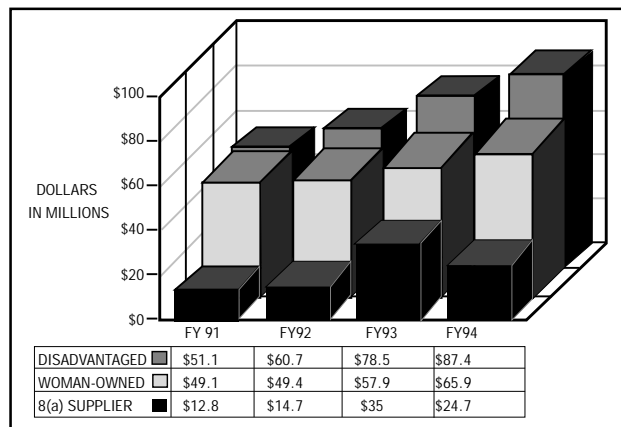

**FIGURE 2-12. SOCIOECONOMIC ACTIVITY**

---

include the Small Business Association's Eisenhower Award for Excellence (1993), the Small Business Association Distinguished Prime Contractor Award (1989, 1992) and other numerous awards from both the Association and DOE. The labs have always had an active small business program, and the set-aside program is a new requirement for 1995.

## Quick Pay Invoiceless Payment Processing

By developing a Quick Pay Invoiceless Payment Process, Sandia National Laboratories now have a paperless invoice system that pays the supplier automatically upon receipt and validation of material. In June 1993, Sandia implemented this system, one that allows Sandia to automatically pay for materials which have been received in accordance with the terms of the contract but without requiring a supplier invoice. Prior to Quick Pay, Sandia accounting was responsible for logging a purchase and processing the vendor invoices. Files had to be maintained with hard copy invoices for auditing purposes. The cabinets to hold these files consumed space and necessitated personnel.

A team from Sandia visited the Ford Motor Company to review its invoiceless system and determined that the system could be tailored and adapted for SNL use. Using agile manufacturing philosophies, the team developed an enhancement to its system. When a purchased item is received and validated, the system feeds the shipper number into the system, setting up automatic payment.

SNL and their suppliers have both benefited. For the supplier, there is no invoice to generate and send, payments are made in a timely manner, and problems with lost invoices are eliminated. Sandia saved \$15K in 1994 by not processing supplier invoices, equal to one-half Full Time Equivalent and requiring no storage space. The system has eliminated invoice handling, and Sandia National Laboratories rarely make late payments, capturing 98% - 100% of their discount opportunities.

Sandia National Laboratories have found that an ongoing education process is critical for success because of employee reassignment and continually establishing new suppliers. In pursuit of continuous improvement, Sandia is looking at iterative payments (progress payments) for valid receivables and labor contracts as potential areas to apply the Quick Pay principles.

## Just-In-Time Procurement System

The SNL have a Just-In-Time (JIT) Procurement System designed to put general purpose items at workstations as they are needed. It is an automated ordering system designed to allow the end user/requester to place an order for commercial, off-the-shelf, low-dollar items. It has eliminated the need for a conventional purchase order and storage area. The

automated JIT system provides Sandia National Laboratories personnel the opportunity to order supplies when needed from a personal computer. The system provides information on the supplier's quality and delivery of products.

This system was created ten years ago to eliminate the need for a buyer- middle man which caused delays resulting from the procurement process and workload. It eliminated the need for a warehouse and attendants, and the warehouse now houses the procurement department, and the attendants are involved in other productive tasks.

Part of the success of this JIT system is from cultivating proactive suppliers who expedite orders rapidly, maintain inventories, and provide direct communications with the requester. To get this commitment, Sandia National Laboratories has developed long term relationships, and fostered a service-level requirement which created a win-win relationship.

The JIT system has eliminated storage requirements, reduced waste, removed the buyer as a middle man, and realized an \$11M annual savings. With the automated system and the partnership between Sandia National Laboratories and its suppliers, supplies can be delivered as quickly as the same day and the supplier paid within a week of receipt.

## PERSONNEL REQUIREMENTS

### Total Life Concept Health Promotion Program

Total Life Concept (TLC), SNL's employee health promotion program, provides awareness and opportunity for all employees and their families to achieve and maintain physical and mental health and well-being through a supportive environment. Since its start in 1986, over 60% of the employee population has participated in one or more TLC programs. All programs are free and open to all Sandia National Laboratories employees and their families.

The program has four goals:

- To continually improve health promotion programs to meet the changing needs of the organization and to facilitate the Sandia National Laboratories strategic plan.
- To continually improve health promotion programs to meet the changing needs and health risks of the individual.
- To enhance the synergy of health promotion and occupational health services.
- To become a recognized leader in corporate health promotion.

TLC programs and services include a wide variety of fitness, nutrition, and stress assessments; group exercise

classes; education and life styles programs; individualized exercise programs; fitness forever incentive programs; security fitness programs; special events; and a strong commitment to help the participant succeed. These efforts are supported by health educators, exercise physiologists, and nutritionists. TLC programs and services are based on the most current and effective strategies in preventive health care.

The TLC health education program addresses life style issues from back care to self esteem. The stress management program includes individual and organizational stress assessments and consultants. TLC offers classes for increasing health awareness and building skills for healthy behavior change. These programs include blood pressure control, cancer awareness/self care, smoking cessation, controlling anger, communicating for success, and cholesterol screening.

The TLC nutrition staff supports a program for promoting good dietary habits by providing a wide variety of educational seminars and classes designed to help employees to make healthy food choices. This includes nutrition assessments, cooking demonstrations, and supermarket tours to assist in improving nutritional skills.

TLC's impact on Sandia National Laboratories population can be seen in changes in physiological variables, changes in knowledge, attitudes and behaviors, a noticeable change in employee health status, and a reduction of medical claims costs.

TLC has won the Johnson & Johnson Quality Audit Best Business Practices for its medical referral process form, innovative programming, and program evaluation component (Figure 2-13). In 1993, TLC received Sandia National Laboratories President's Silver Quality Award. They have been recognized in publications such as the *American Journal of Health Promotion, Fitness for Business*, and the *Journal of the American Dietetic Association*.

## DATA REQUIREMENTS

### Integrated Records System for High Reliability Production

Sandia National Laboratories implemented a fully integrated Records Management System to maintain and track records of high reliability components and electronic assemblies used in space and military applications. The system, created to help track component and assembly lots, merges financial, procurement, design, assembly and integration, delivery, and quality assurance information. Previously, when a potential problem was discovered within a certain component lot, extensive searching through archived

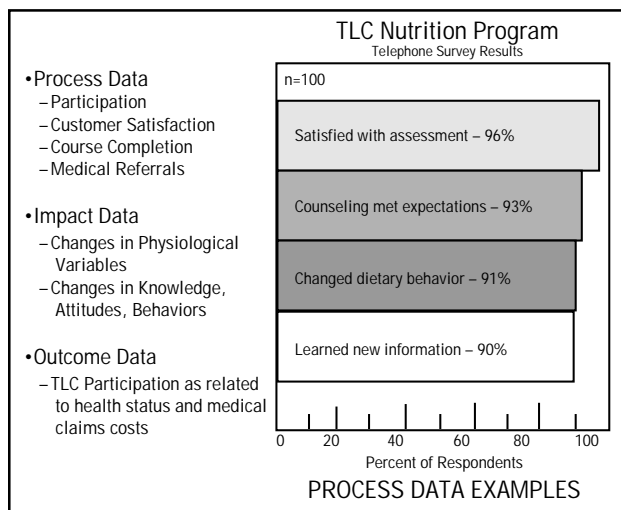

FIGURE 2-13. PROGRAM EVALUATION

documents required days or weeks to locate the affected components. If already in service, the components could produce a reliability concern during the location and recall effort.

To address this issue, it was determined that the new database should be platform independent for access from any machine. In addition, to avoid duplication of effort, it was decided that all information needed to support product realization would be entered once, or electronically acquired and entered, at the most logical step in the manufacturing cycle. This data would not be re-entered and would be accessible by all personnel who required it at every step of the manufacturing cycle.

This system provides full and accurate traceability for procured and manufactured materials. To facilitate the exchange of information, the system is available via modem and Internet to allow employees at other locations and other companies to access this information.

The record center maintains and controls all information concerning satellite system design, fabrication, and test. Inventory control is enhanced since the system tracks quantities in stores and those on order to avoid duplication of soon-to-arrive components. Although parts in the system are stored at one location, part ownership is maintained electronically. The part cost and lot number are linked to the project to help determine project costs as well as the needed traceability.

This integrated records management system, developed to support the product realization of high-reliability space-based hardware, has been very successful in many areas. It utilizes the experience and meets the needs of each person relying on the data collected to efficiently perform assignments, facilitate traceability and recall efforts, and allow for tighter inventory control.

## Nuclear Waste Management Center's Computer Support Tracking System

The Nuclear Waste Management Center's (NWMC) Computer System Support Tracking System has been developed to establish communication with Center customers, assuring them that problems and requests received are handled professionally and quickly. The system support group is located off site at the BDM/GeoCenters Complex. The system was designed inhouse and implemented with the expertise of this group.

The architecture of the system includes Sun, VAX, HP, PC and Macintosh machines. The software product for development was Xbase Software, called Recital which supports multiple platforms. Prior to development, a staff of fifteen supported end user requests with mental "memos" and notes passed among the group. It became clear that improvement was needed to in consolidating requests and problem reports, improving communications with customers, and facilitating and monitoring personnel assignments. Improvements to the system have produced a capability to provide metrics to support funding and resource allocation requests. The system utilizes the Sandia mail system for communications and voice mail.

Additional benefits include automatic notification to customers of changes in status, proper tracking, progress and closure, support personnel assignment lists, and the ability to provide both on-line and hardcopy reports. Management metrics can be obtained by department, project and support personnel. Future directions are to implement Graphical User Interface and integrate with other Windows applications. A video conference room is now available for customers and end users to schedule meetings.

## MANUFACTURING STRATEGY

### Application of Quality Function Deployment to Battery Design

Sandia uses the Quality Function Deployment (QFD) process as the organizational aid in integrating the ability to determine product requirements from customers' needs and expectations, and ensure that these requirements are realized in a product or service. Integrating these customers' requirements into a commercial product is best accomplished through a step-by-step process, a primary reason for Sandia choosing QFD, a structured product planning and development tool, first used in Japan, to guarantee customer requirements are realized throughout the product life cycle.

The QFD process is a structured activity that begins with a conceptual design and ends with a technical data package. In Phase I, a cross-functional team translates key customer requirements into product measures that, if satisfied, will

ensure customer satisfaction. Phase II translates the key product measures into parts characteristics. In Phase III, key parts characteristics are translated into manufacturing process characteristics. Finally in Phase IV, these manufacturing process characteristics are translated into manufacturing process controls. This structured deployment of key requirements guarantees that the product development team maintains its focus on these requirements and realizes customer's needs and expectations repeatedly in the manufacture of the product.

Application of this process is demonstrated with Sandia's battery design. Since 1980, Sandia has used lithium/sulfur dioxide "D" cell batteries to provide highly reliable, continuous power (up to 5 years) in weapons applications. Because of the lab's responsibility to meet demanding DOE requirements, the Exploratory Battery Department demonstrated the feasibility of adapting an improved and innovative design to an established commercial lithium/thionyl-chloride battery technology that revolutionizes the way nuclear surety devices are powered in weapons. By using this new cell, in conjunction with new generation multichip module technology electronics, the size of the power supply can be reduced 50% and the service life doubled while maintaining ambitious safety and reliability requirements. To achieve this goal, the Product Realization Team (PRT) utilized the QFD four stage process (Figure 2-14) to guide the technology transfer effort and to communicate progress to the customers.

Applying QFD to the battery design produced the following results: a longer service life which increased the limited life components exchange interval, resulting in time and cost savings in nuclear weapons stockpile maintenance; and lithium/thionyl-chloride cell manufacturing costs which remain comparable to the cost of the lithium/sulfur dioxide

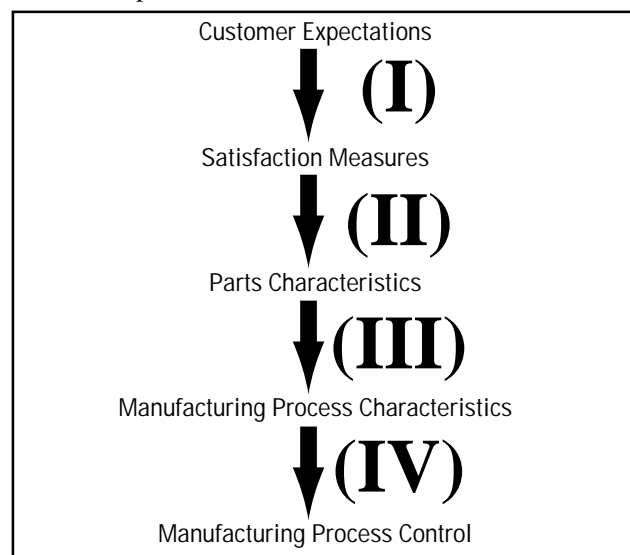

**FIGURE 2-14. THE QFD APPROACH**



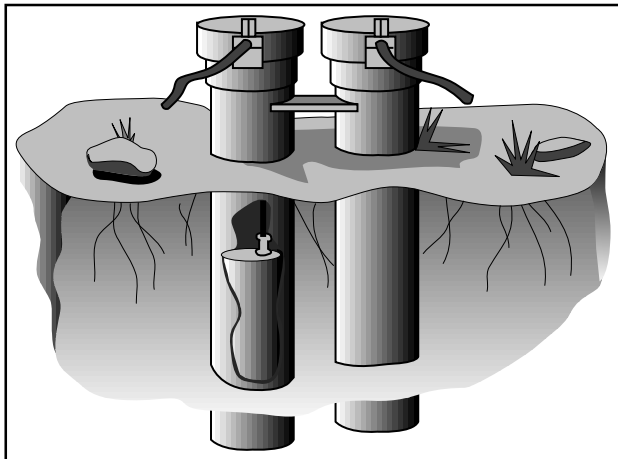

**FIGURE 2-15. FACT SHOTGUN BOREHOLE**

cell, while maintaining the same manufacturing quality.

The technology to produce this product for Sandia National Laboratories applications was successfully transferred to a commercial manufacturer, Eagle Picher Industries, Inc., Joplin, MO, enabling it to produce a variation of this cell for commercial application. Additionally, the Exploratory Battery Department was awarded Sandia National Laboratories 1994 President's Silver Quality Award for this effort.

## QUALITY ASSURANCE

### Evaluation of Low-Noise Seismometers

Sandia is chartered by the DOE and DOD to evaluate seismic data acquisition systems to monitor international treaties limiting nuclear weapons underground testing. Maintaining the testing philosophy of using optimum available methods and simulating actual use conditions whenever feasible, SNL developed a shotgun borehole testing system for testing seismometers using coherence analysis. Since the earth movements from underground nuclear explosions are very small, Sandia discovered that developing a standard calibration input, such as a shake table, would not be feasible.

The shotgun borehole testing system has been developed at Sandia's Facility for Acceptance Calibration and Testing as an alternative to the less accurate vault testing system. In shotgun borehole testing, tubes are inserted in boreholes to a depth of 100 meters (Figure 2-15). The tubes are welded together at 15-foot intervals so that similar seismometers placed in each tube receive the most equivalent input signal achievable since both seismometers sense the same earth movements. Sandia has both double and triple shotgun borehole test facilities at the Facility for Acceptance Calibration and Testing site.

Seismometers inserted into shotgun borehole systems at Sandia are tested using coherence analysis. This Sandia-developed test method acquires ground motion data from two or more similar seismometers in neighboring boreholes simultaneously. This data is used to estimate the internal noise characteristics and relative transfer function between the seismometers. The accuracy of the seismometer is then determined by comparing the test information against the most accurate seismometer currently known, and its noise performance is compared to the Low Earth Noise model.

The combined system of shotgun borehole testing and coherence analysis enables Sandia to evaluate seismometers to the most accurate extent possible. This level of accuracy is essential to the effective monitoring of international treaties.

## COMPUTER-AIDED DESIGN

### Advanced Manufacturing Technology Network

An Advanced Manufacturing Technology Network (AMTnet) has been established at Sandia to serve as a single point of communications for Sandia's outside customers. It allows internal and external network communications to use a broad range of communications protocols from WAN environments to high speed dial-up using PC modem connections (Figure 2-16).

AMTnet was developed to address a communications problem between SNL and their customers, particularly when trying to effectively work within a consortia of companies of various sizes, financial resources, and equipment capabilities. To effectively work in an interactive concur-

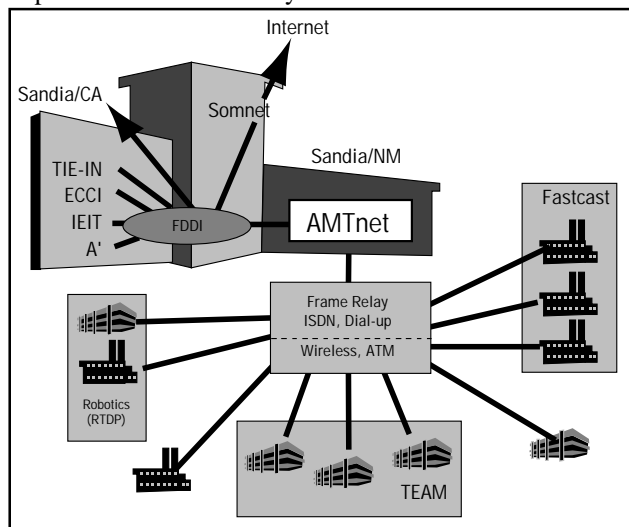

**FIGURE 2-16. ADVANCED MANUFACTURING TECHNOLOGIES NETWORK**

---

rent engineering environment where designs were shared between geographically isolated partners, as well as those with various grades of computational and communication equipment, was extremely difficult.

AMTnet, designed to aid in implementing interactive concurrent engineering, agile manufacturing, effectively establishes what is - in effect - virtual corporations, and at high speed and low cost. Because of difficulties working with Internet and because many smaller companies do not have access to Internet, a network that can handle data in the range of 100 Kbps to a few Mbps and at low cost is definitely required, and

this is the capability that AMTnet presents. It is actively used by several consortia of companies working with Sandia.

The system utilizes several dial-up numbers depending on the communication link being used. Typical costs for these communication links range from \$500 to \$5K per year. These costs are normally within the budget of any company, and the AMTnet allows for communication between these companies if they are members of the net. This network also allows for communications to anyone within the Sandia complex (within some level of security) as most internal LANs are provided gateways to AMTnet.

---

# SECTION 3

## **INFORMATION**

---

### **3.1 FUNDING**

#### **COST ASSESSMENT**

##### **Controlling Manufacturing Costs Using Activity-Based Costing**

The Service Center Information System (SCIS) is a computer-based cost tracking system that allows Sandia National Laboratories management control of the size of various activities by funding only those services used within a process. This enables the accumulation of the true cost of performing a specific task.

Prior to its application, overhead costs to customers were charged through a single rate for each service center, where rates were adjusted to ensure full cost recovery. It was difficult for customers to monitor progress on work orders, know when charges would occur, how much would be incurred, and what was included in the total amount. Sandia National Laboratories found it was impossible to evaluate the cost and recovery for any given activity.

Development and implementation of SCIS was a joint effort between Sandia management and its end users. Common goals included (1) implementing a corporate-wide activity-based costing system, (2) distributing service center overhead to improve cost management and accountability, (3) recording and managing agreements between the service centers and customers (both internal and external), and (4) validating accounting information and funding.

SCIS features real-time processing of service orders, weekly updates to the financial system, multiple interfaces to other corporate systems, and on-line query capabilities. It has provided a more thorough understanding of the direct and indirect costs of doing business, making the job of evaluating corporate effectiveness and efficiency easier.

### **3.2 DESIGN**

#### **DESIGN POLICY**

##### **High Consequence System Surety**

SNL has brought together a multidisciplinary team to integrate the various elements of surety, safety, security, control, reliability, and quality into a new and encompassing process that will provide systems with insurance against

unintended adverse consequences. The High Consequence System Surety (HCSS) project enhances systems with surety as an encompassing, up-front, designed-in process for high consequence operations. Initiated in 1994 for use on an internal project, HCSS is in fact a surety methodology. Previously, the total system was often not considered, and disciplines for surety were applied only as needed throughout the project life. Surety discipline interrelationships were not fully examined or applied in a timely fashion, resulting in a layered approach.

The HCSS methodology is based on designing surety into the system up-front and providing for the means to examine and ensure the system will maintain its surety throughout its use. The customer can determine what trade-offs are acceptable based on analyses that prioritize the high consequences associated with the various risks involved. HCSS offers the customer information solutions to ensure correct system operation through the integration of the appropriate levels of security, integrity, reliability, safety and functionality. The SNL maintain that HCSS is a continually evolving process and ongoing project aimed toward product design and development.

#### **DESIGN PROCESS**

##### **Electronic Design Automation Process**

The Monitoring Systems and Technology Center of Sandia National Laboratories is an engineering collective with a core competency in designing, building, and testing high reliability satellite spacecraft payloads. The Center has developed a process and capability to reduce design cycle times and provide increased quality with greater design information availability.

This process integrates Electronic Design Automation tools into a concurrent engineering environment to improve product realization and process efficiency, and provides automated tools to design engineers to support intelligent design decisions before committing to product realization. The process also enables obtaining a manageable level of quality control which is consistent and repeatable. It provides a seamless process from design to production to reduce product errors and maintain data integrity throughout the process, as well as creating a single repository for design data.

Enhancements under development include system level modeling, simulation, and automated systems engineering.

---

The system currently supports electrical and mechanical design capture, optical design and design options for digital and analog design. Other areas supported are a manufacturing-approved component library, automated electrical/mechanical interface, multilayer PCB design including high frequency design and integration with automated test equipment tools as well as a hardware modeler. All activities have traceability, document control, and parts inventory integrated with a relational database.

## Laydown Weapons Parachutes

Sandia has maintained the responsibility for development, production, and stockpile maintenance for Laydown Weapons Parachutes since 1954. To complement this mission, Sandia has a Parachute Development Laboratory and a Parachute Materials Quality Assurance Laboratory which provides analysis and experience in high-speed, low-level Air Dynamic Deceleration Systems.

The key components of the development mission are to provide a complete design (technical data package) which may require Prototype Fabrication and Packaging, testing, and Design for Manufacturability characteristics. For the production mission, Sandia is responsible for complete deployment and maintenance of technical drawings, technical manuals, and quality assurance documents. In addition, the group is responsible for the development and maintenance of training of parachute packers and inspectors. Lastly, as part of Sandia's stockpile maintenance role, reviews of Joint Test Assembly Test Data, Aging Studies, and continuation of consultant roles for defect reporting from the field are conducted.

Sandia has supported DOD and NASA in assisting various deployment systems in parachute designs and analysis. Payloads up to 175K pounds including weapons, cargo, reusable hardware, instrumentation, and personnel represent some of the diverse experience Sandia possesses.

Sandia is working with DOE, DOD, NASA and private industry to develop physical understanding and computational models of the fluid dynamics of parachute inflation processes. These processes are being developed into a centralized Sandia Parachute System Simulation tool. The processes include independent modules with standalone design codes, integrated trajectory design packaging, integrated parachute design packaging and material database management. To preserve parachute technology, Sandia is documenting today's parachute inflation research as part of tomorrow's parachute design tools. These parachute design tools are shortening the parachute design cycle time and reducing costs.

## A-PRIMED Process Improvements

SNL's A-PRIMED project is a strategy for fast-tracking design and implementation of components. Key elements of this program include bringing all project participants together at the project's beginning, developing a seamless information network, creating parametric design for rapid evaluation of product possibilities, automatic planning of fabrication and assembly processes, and using machine and process characterization to help produce a correct product the first time. The A-PRIMED project is comprised of several teams concentrating on specific Sandia-developed technologies such as Parent-Child Design using parametric programming; Improved Virtual Prototyping using automated mesh capabilities; First Part Right using rapid prototyping; Concurrent Engineering Communications including Interactive Collaborative Environments; Low Volume Qualification including Design of Experiments and Machine and Process Characterization; and Automated Assembly software running a robotic workcell.

Although development activities are still underway in all areas, the project is already beginning to produce major improvements in targeted activities. For example, in automated finite element mesh generation, the time to produce a mesh for a object of 200 edges has been reduced from 28 to 3 days in the past year. Programming and setup time for maze-wheel manufacturing has been reduced from more than 35 to less than 10 days. Similar improvements have been made in infrastructure areas such as the number of team members and buildings connected by communications services.

Technology briefs have been prepared for each subproject which provide brief summaries of project objectives, recent achievements, capabilities overviews, and technical contacts. Each of these A-PRIMED target techniques are developing and demonstrating processes and techniques for improving the design-to-production cycle for precision electromechanical devices.

## Laser Spot Weld Representation

Although current CAD systems model part geometry very well, they are limited in their ability to model assemblies and the "liaisons" between components. The SNL have extended their design system to represent one type of liaison information between components, specifically welds. The laser spot weld is a simple part-to-part relationship that can be modeled; information and extensions include which parts to join, geometry such as points and curves, design parameters such as depth and diameter, manufacturing parameters such as power and aperture, and modeler interactions such as what data must survive editing operations.

---

Extensions include both representing weld information and providing access to weld data for the robotic assembly planning module used in the A-PRIMED project. Current work is focused on expanding this capability to support fastening operations such as gluing. Enhanced design capture, better sharing of design information, management of legacy data, and enabling automation through other software systems such as robotic assembly planning are all benefits derived from this capability.

## Concurrent Engineering in the Recode System and Thermal Batteries

Two programs at Sandia National Laboratories highlight what can be achieved using the concurrent engineering process. This approach was demonstrated in the successful development of thermal batteries and the Air Force's Strategic Command Secure Recode System.

Sandia was faced with a decreasing customer base which required a new look at the process used to develop thermal batteries. Historically, they were designed for a specific application, then passed to the production staff for fabrication. Stockpiled units were returned to the design group for analysis at a later date. Utilizing the concurrent engineering approach, Sandia created PRTs consisting of the customer, systems engineers, technologists, design and development engineers, manufacturing engineers, and test engineers. A Design and Manufacturing Guide was created to specify standard processes and materials available for use in the product design. This effort was coupled with a formal review process to enable Sandia to maintain the technology base and product quality at a reasonable price in a declining market.

In the case of the Secure Recode System, Permissive Action Link controllers were traditionally developed in the design, manufacture, test sequence. Sandia addressed the cultural resistance to change between themselves, their customers, and their suppliers. Teaming was difficult as all participants learned to appreciate others' needs and to understand the individual values added to the product.

Once the Core Team was established, a QFD approach to concurrent engineering was initiated. The unit price was decreased from \$290,100 to \$31,578, three separate units worked the first time they were powered up after production, and only one development build and one process prove-in build were performed prior to production. The results of the concurrent engineering approach to this problem demonstrate that the team members shared a common goal. Representing the various disciplines early in the development paid off in a greatly reduced number of iterations necessary for production. Also, empowerment of the team to resolve problems resulted in a reduced number of deviations upon production.

These two projects highlight not only the benefits of concurrent engineering in product development, but also Sandia's commitment to addressing the realities of today's market with innovative solutions that meet or exceed customer expectations at a reasonable price.

## Control Device Database/Measurement Software

Sandia's PSL is developing software for a more efficient method for capturing, displaying, and storing data generated during the certification of microwave Vector Automatic Network Analyzers. This software will provide the user with a quick and efficient method to acquire new data and compare it to the history of the control devices. These database files/names should be transparent to the user as the menu-driven software will direct the storage of the data to the correct file.

Some unique features of this data acquisition software include software that automatically obtains a list of frequencies from the network analyzer. The user need only specify the connector type and device, and the software automatically acquires the correct scattering (S)-parameter data, and if new data is acceptable, the software updates the database files. Acceptable means internally consistent with prior data. The consistency check is performed automatically as part of the application of SPC techniques to microwave device certification.

The database files for Network Analyzers contain three types of files that are used to store data. A Control Device measurements file contains the measured data on a specific device for a specific date and time as a function of the measurement frequencies. A database file contains all measurements on a specific device and a summary file that contains the number of measurements, mean, and standard deviation at each measured frequency. The summary file is automatically updated when new data is stored in the database file. All these files are ASCII format and are stored in the DOS file system.

When implemented, all database files will reside on DOS directories on the LAN system. The plots may be directed to either DeskJet or ThinkJet printers. Other plotters and printers will be supported in the future.

Because most of the software has been written in HP BASIC, the user is not required to switch to another operating system to plot data and update databases. All database files are stored as DOS files in ASCII format and may be imported into other spreadsheet or database files if more sophisticated plots or correlations are desired. Although this system was designed for the unique requirements of the Microwave Project, the software may be easily reconfigured for a different set of requirements for a customer.

---

## Utility Battery Storage Systems Program

The Utility Battery Storage Systems Program, sponsored by the DOE and directed by the Storage Battery Department at Sandia, cooperates with the electric utility and manufacturing industries to develop battery storage systems. The elements of this comprehensive program are Battery Systems Analysis, Subsystems Engineering, System Integration, System Field Evaluation, and Industry Outreach. The concept behind the Utility Battery Storage System is to store electrical energy for dispatch when its use is more economical, strategic, or efficient. From the utility grid, the battery systems can store off-peak energy and return it on demand as needed.

The system consists of a power-conditioning system, batteries, a control system, and auxiliary devices that include transformers, electrical ties and interconnections, support structures for batteries, and shelter for the assembly.

The incorporation of the battery systems can provide greater utility grid stability by serving as a controllable, demand-side management option that provides customers improved power quality and uninterruptible power. By storing electrical energy, the utilities can ensure reserve power requirements, defer new power plant construction, provide support for existing transmission and distribution systems, and maintain the level of reliability and power quality that customers need and expect. The widespread introduction of battery storage systems by utilities could also benefit the U.S. economy by more than \$26 billion by 2010 and create thousands of new jobs.

## Engineering Analysis Contribution to Agile Manufacturing

SNL addressed the problem of providing an automated finite element mesh for stress and thermal load calculations in agile manufacturing and fast prototyping by developing a software package called CUBIT. This package can lay out the finite element mesh, and Sandia has successfully applied it taking information from ProEngineer and establishing a mesh suitable for detailed analyses. Sandia maintains that time and cost savings are significant, particularly if the mesh must be finely and unevenly spaced throughout the structural component under analysis. These savings can amount to weeks. Although this type of work is currently conducted in most leading-edge industries and labs, Sandia's code may have capabilities that others on the market do not have.

## Engineering Simulation for Model-Based Design

The Engineering Sciences Center at Sandia has an analysis capability comparable to many engineering and manu-

facturing companies, and is currently integrating its computational capabilities into an engineering "toolkit" for both conventional and many leading-edge analysis problems. The Engineering Sciences Center performs work in manufacturing and environmental fluid dynamics, thermal and fluid engineering, thermophysics, engineering and manufacturing mechanics, materials and structural mechanics, energy and multi-phase processes, aerosciences and fluid dynamics, and fluid/structural interactions.

Many computational codes have been developed from the weapons program requirements and can be used to analyze many engineering problems such as glass to metal seals. The Center can analyze non-linear large deformation mechanics and structural dynamics, non-linear response of polymers, as well as standard analyses of fluid dynamics, heat transfer, and metal damage and failure, including composite mechanics. The Center can also perform welding mechanics analysis under dynamic conditions such as laser welding, metal forming, material removal, and coating processes. An experimental mechanics group complements the analyses groups in helping to benchmark computational codes.

The Center's capabilities in engineering mechanics have already been applied in investment casting, induction hardening, coating, microelectronics manufacturing, foam processing, polymer processing, liquid metal processing, metal forming, and material joining processes. An example of the unique computational capabilities is stress analysis for a hole punching operation. For a quick and accurate model, Sandia dynamically remeshed it using an analysis toolkit developed within the Center that provides rapid access to state-of-the-art mechanics codes. These codes interface through an in-house file format, Exodus II.

## Fuzzy/Probabilistic Hybrid Analysis

Performance assessment is predicated on how a system is expected to perform. Probabilistic methods are traditionally used to extract mathematical models for system risk assessments. These models are dependent on a known probability distribution and work best for deterministic (measurable or modelable) situations.

The System Studies Department and the Assessment Technology Department of Sandia are developing methods for using fuzzy logic to address unexpected or abnormal-environment assessment. Some causes of these uncertainties can be natural variability, measurement variability, sampling variability, reporting biases such as human interpretation and selection, and incomplete knowledge.

The utility of fuzzy logic arises from the fact that fuzzy measurement is based on opinion, not on quantitative measurement. Fuzzy uncertainty requires no assumptions about probability distributions, and fuzzy mathematics are simple and direct. These attributes make it applicable to such tasks

as safety assessment where warning of undesired and unexpected performance features is critical. Fuzzy estimates require less information about characteristics at the tails (extremes of the variability) which is often not available.

Tools are being developed by Sandia for performing fuzzy/probabilistic hybrid analysis and generation of three-dimensional visual images to graphically demonstrate probabilistic estimates. Sandia will continue investigation of representations for fuzzy and hybrid knowledge, to investigate and develop methods for measuring scale factors, to incorporate variable scale factors, and to construct a complete mathematical assessment.

## Integrated Assembly Planning

Because modern products have more parts, are designed faster by different designers, and are packed into a smaller volume, Sandia performs automatic assembly planning to aid in manufacturing. The design is checked using this application to ensure that products can be easily assembled, serviced, and disassembled. This confirms design assembly ease, checks designers' assembly plans to avoid costly mistakes, reduces time to market by automating parts of the production planning process, and gives feedback to designers regarding the assembly and disassembly process.

Automatic assembly planning has many advantages over traditional methods of analyzing assembly processes. The process can be verified and code generated for robotic programming before the product leaves the design stage. This can be used with solids modeling in design for assembly analysis tools, as well as for disassembly analysis to aid in the recycling of future products.

This work is part of the Archimedes Project in the Intelligent Systems and Robotic Center and provides the A-PRIMED project with assembly manufacturing feedback and automated robot workcell programming. The project takes solid computer models of parts and determines if the parts can be fit together. It also checks if parts can be easily inserted or removed from the final assembly for maintenance, repair, or assembly. In addition, this project checks to ensure there is room for the necessary tools and working tool space. The project maintains a goal to build and demonstrate an assembly planning system that could assemble products in robotic workcells and provide designers with useful feedback on the assembly process.

Future improvements to the project encompass use of automatic tool selection for the robotic workcell including screwdrivers, wrenches, laser welders, grippers, and cameras. Other work includes improved reasoning in assembly algorithms and reasoning about flexible parts.

The integration of projects such as automatic assembly planning helps Sandia to improve their manufacturing capabilities and achieve agility in manufacturing.

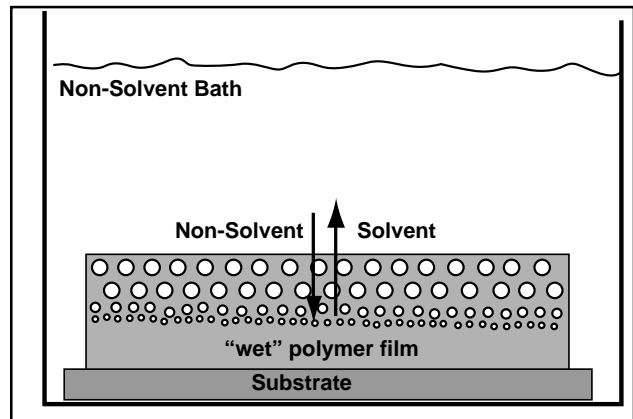

**FIGURE 3-1. SCHEMATIC OF POROUS FILM FORMATION**

## PARTS AND MATERIALS SELECTION

### Microporous Polyimide Films for Reduced Dielectric Applications

Strong demand for fast, highly-condensed microcircuits and the unavailability of low dielectric-constant insulators have led Sandia National Laboratories' researchers to look for alternative methods to insulate multiple layers of patterned conductors in multichip modules. Device dimensions and processing speed are largely limited by the thickness and dielectric-constant value of the insulating material. Therefore, Sandia researchers developed a technique to deposit a sponge-like microporous polyimide to insulate conductor layers.

Researchers found that the dielectric constant of the applied polyimide decreased in value proportionally with pore size and film thickness. The technique developed by Sandia consisted of spin-coating the polymer solution on a wafer, and then immediately submersing the still "wet" wafer in a non-solvent (Figure 3-1). The non-solvent caused the polymer to phase separate out of solution on a micron-size scale, creating the microporous structure. Pore size and film thickness are controlled by the spin rate and time, and higher RPMs yield smaller pores and thinner films. In 1993, researchers were able to deposit a polyimide film with a pore size of 1-1.5 micrometers and dielectric constant of 1.88 at 1 Khz. Results included:

Porosity = 68%

Pore Size = 1-1.5 $\mu$ m

Thickness = 22  $\mu$ m

Dielectric Constant = 1.88 (1 KHz)

Dielectric Loss = 0.002

Stress from Solid Film on Wafer = 20 Mpa

Stress from Porous Film on Wafer = 2.0 Mpa

These values compare favorably considering that silicon dioxide and polyimide have a dielectric value of 4.5 and 3.4 respectively. This decrease in the dielectric constant results in an increase in pulse propagation velocity. In addition, thinner insulation layers minimize cross-talk between adjacent conductors. This enables chip designers to place conducting lines closer and obtain denser microcircuits.

Sandia researchers have shown that porous polyimide films with low dielectric values can be made and applied to multi-chip modules. Film thickness and pore size can be controlled through spin rate and length of spin time. This microporous film can contribute to the manufacturing of faster, denser multi-chip modules.

## PARTS AND MATERIALS SELECTION

### Agile Cable Acquisition and Production System

In partnership with Lockheed Missiles and Space Company and Stanford University, Sandia is assisting in the development and deployment of an Agile Cable Acquisition and Production System (ACaPS). ACaPS allows a cable purchaser to submit design specifications, obtain price quotations, and negotiate the procurement of cable systems electronically via the Internet's World Wide Web. The goal of ACaPS is to reduce cable procurement and production time by conducting these processes in an agile environment.

An ACaPS transaction begins with a prospective cable purchaser submitting a Request for Rough Quote on a standardized form via the Internet to a cable manufacturer (Figure 3-2). The purchaser may post additional design information and specifications to a file transfer protocol site. After review of the design information, the cable manufacturer electronically submits a rough quote to

the purchaser including approximate cost, production start date, and production time. The prospective purchaser reviews the rough quote and, if acceptable, electronically requests a final quote from the manufacturer. Upon receipt of the final quote, the purchaser electronically submits a purchase order on a standardized form.

In a controlled test exercise using ACaPS, Sandia was able to negotiate the procurement of a typical cable harness from Lockheed in two days. This was a significant reduction in procurement time from the two to nine months typically required. Sandia estimates that an actual ACaPS transaction, similar to the test exercise, could be completed in thirty days.

Sandia is actively working to expand the application of ACaPS to procure machined parts and other components. As manufacturing becomes increasingly agile, rapid procurement systems such as ACaPS will set the standards for electronic commerce.

## SOFTWARE DESIGN

### Software Process Improvement

Sandia National Laboratories' Quality Engineering Department has developed a software process improvement (SPI) approach to improve individual Sandia organization's software processes. This approach is part of a company-wide software management program initiative.

Sandia had no company-wide policy on software management. Requests for software quality engineering were on a case-by-case basis typically late in a project development. Processes were not cost or benefit efficient. The software management program initiative has recently established a company-wide policy requiring organizations to document their software management approach, and the SPI approach to assist organizations in improving their processes.

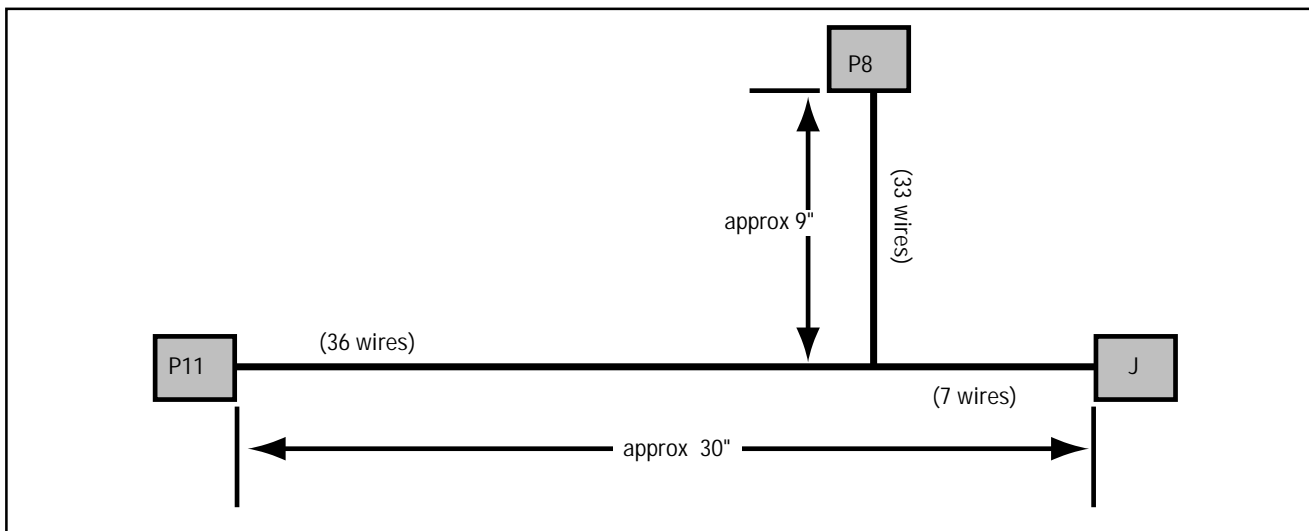

**FIGURE 3-2. ROUGH QUOTE CABLE HARNESS DRAWING**



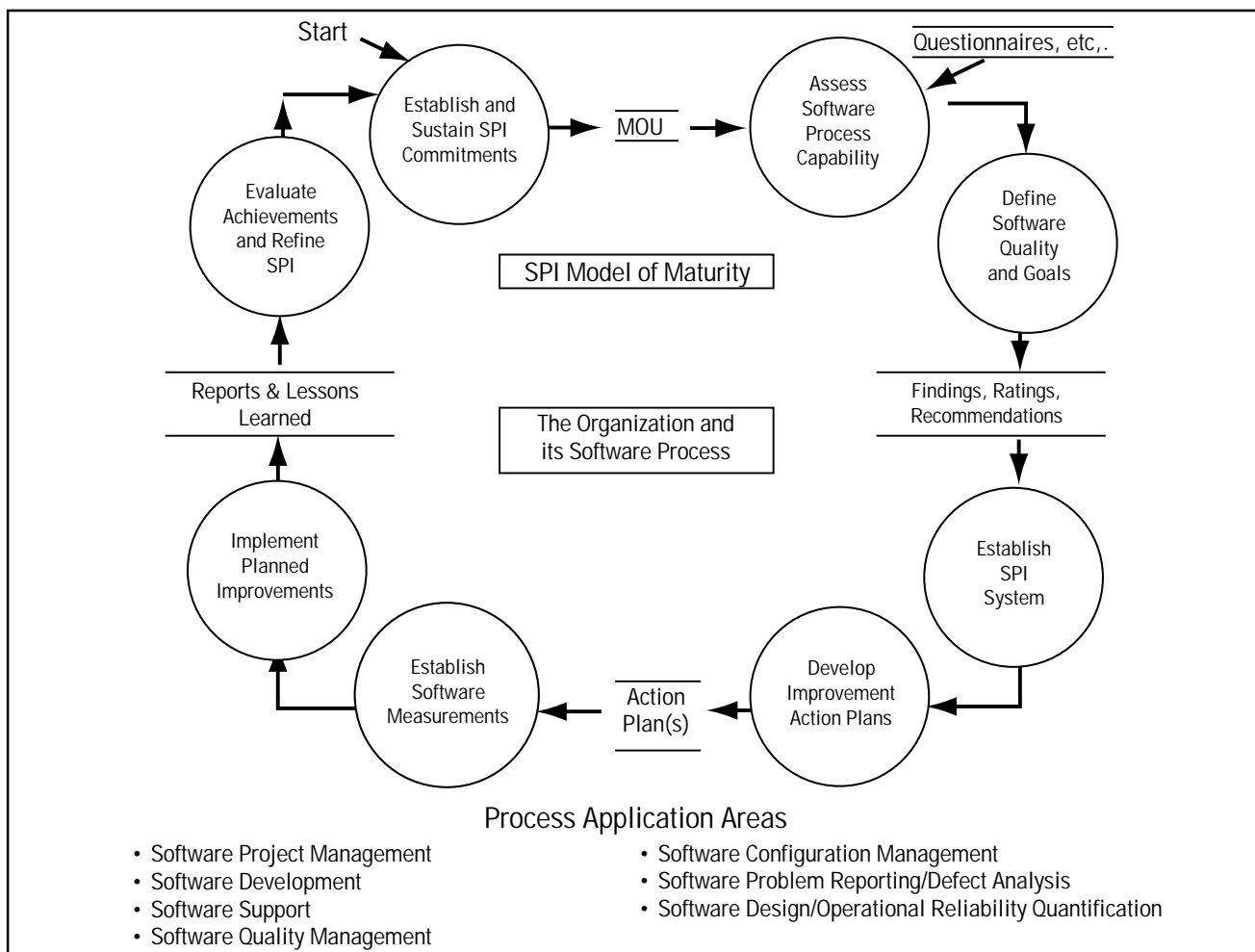

**FIGURE 3-3. SOFTWARE PROCESS IMPROVEMENT METHOD**

Sandia's organizations vary widely in their applications and the practices used to produce software products. Sandia's SPI approach is tailored from a SEMATECH approach to address specific Sandia organizational needs. The SPI approach consists of eight steps (Figure 3-3).

The first step of the SPI approach is to establish and sustain SPI commitments from executive management. A memorandum of understanding is generated to establish the commitment from upper management. Baselineing the software process capability of an organization and targeting customer-oriented improvements are accomplished through questionnaires and an assessment process similar to the Software Engineering Institute's. Software quality and goals are defined and the SPI system is established. Improvement action plans are generated and metrics to be measured are determined. Improvement plans are implemented and lessons learned are fed back to evaluate and refine SPI in a continuous manner.

Sandia implemented some process improvement activities for a non-real time nuclear weapons application with safety and security specific issues. This application consisted of three major hardware components and four major software ele-

ments. Software inspections and improved system integrated testing process improvements were planned. Significant savings were generated by finding major defects during inspection. Slightly over three percent of the software budget was used for the inspections and the reduction in retest saved 18.9% of budget and time. Greater than 85% of major defects were found in inspection instead of in test or operation. More than 40% of software requirements flaws were due to concept/system requirements defects.

As customers approach Sandia with requests for software process improvement, Sandia is prepared to demonstrate how their processes are cost effective and well controlled. The process inherently has continuous improvement to provide growth for the future.

### Computer-Aided Molecular Design – Fullerenes

The SNL performed computer-intensive quantum chemistry modeling to determine the structure and energetics of a newly discovered allotrope of carbon named a fullerene.

Fullerenes are the third structural form (or allotrope) of carbon (Figure 3-4). Discovered in late 1990, this new allotrope is being intensely investigated in universities, industry, and at Sandia.

Fullerenes are geometrically hollow spheroidal arrays of carbon hexagonal and pentagonal rings formed into a geodesic dome-like structure and have possible use in advanced materials in electronic, optical, structural, and high energy (rocket fuel) applications. Fullerenes may also have potential as lubricants, filters, catalysts, and pharmaceuticals. The material is still being studied and characterized in some of its isomeric forms.

The work at Sandia is largely computational with some experimental synthesis. The modeling uses very large quantum chemistry software programs that solve Shroedinger's equation in the Hartree-Fock Approximation for these very complex isomers such as  $C_{60}H_2$ . The codes predict the lowest energy isomeric states using a geometric relaxation of the crystal lattice, a task that may require up to five CPU days on a Cray Y-MP computer. Once the lowest energy isomers are predicted, they are analyzed to determine if their energy levels are sufficiently below the higher levels to warrant attempting an experimental synthesis. Standard analytical chemistry tools such as Mass-Spec, high pressure liquid chromatography, nuclear magnetic resonance, as well as ultraviolet and visible spectroscopy were used to verify the presence of the structure.

This pioneering work in the basic materials science arena should be followed closely for possible uses.

## COMPUTER-AIDED DESIGN

### Electrical System Simulation and Analysis

SNL previously designed analog circuits using a design and build philosophy. Not only was the lab testing costly, but it was very difficult to test field units operating with intermittent problems. To reduce test costs and obtain more insight into their designs, the SNL have begun using CAD tools to design and simulate analog designs.

CAD simulation tools offer SNL design engineers a large range of options. System tests can be performed unobtrusively without expensive test equipment and most importantly, without any part of the system under test being present. This is an important consideration when a system at a field site develops intermittent problems. Using simulation techniques, possible causes can be evaluated and a solution can be recommended. System interfaces can be verified to contain expected signals, and associated cable lengths can be verified to transmit signals as designed. Simulation can also be performed at the component level. CAD offers SNL engineers the flexibility to clip out a section of a circuit and simulate its performance under a

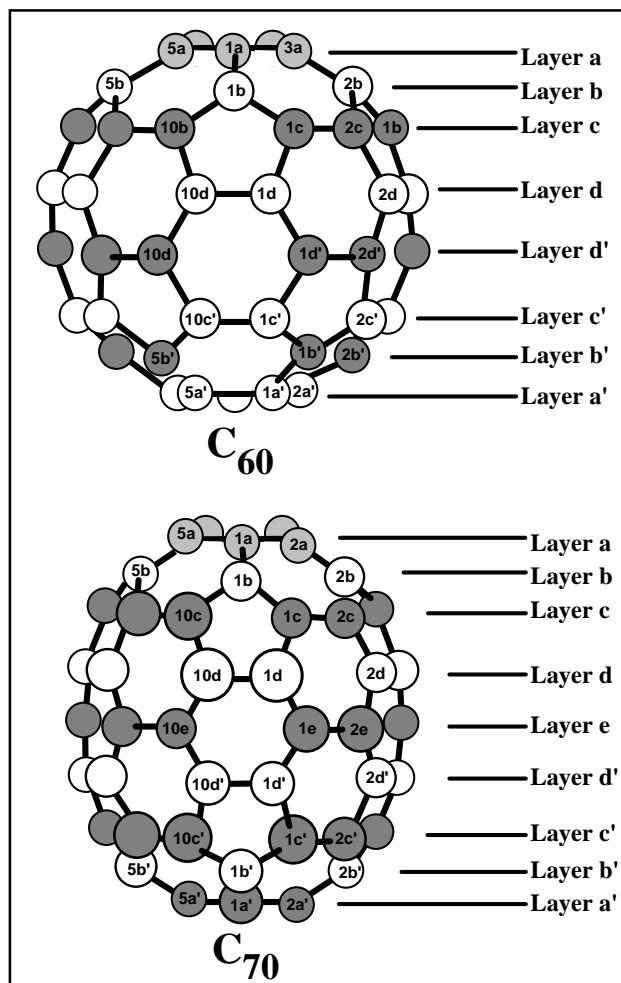

FIGURE 3-4. DIAGRAM OF A FULLERENE

variety of conditions. A virtual laboratory is at the disposal of the design engineer. The SNL, using PSpice by Microsim Corporation, have developed a particular expertise in developing component models for complex high current/voltage analog devices. In addition, the SNL produce good models over temperature variations and radiation effects.

CAD tools have effectively helped SNL engineers find discrepancies early in the design phase, thereby preventing costly lab test time. Intermittent failures encountered in the field have been analyzed by SNL engineers and solutions have been cost effectively determined.

## DESIGN REVIEWS

### Virtual Collocation of Product Realization Teams

Sandia National Laboratories assembled a multi-disciplinary PRT to design, develop, and validate a new telemetry system for defense applications. This PRT

was composed of personnel from three remote sites at Sandia, California; Sandia, New Mexico; and Allied Signal, Kansas City. The team was challenged to reduce the product realization time from two years to one year. Since personnel and equipment resources from each site were required to complete the project, physical collocation of the PRT was not feasible.

To overcome typical team problems associated with remote sites, Sandia virtually collocated the PRT. CAE stations networked between the three remote sites enabled each PRT member to work on a single design definition database using Intergraph Ace Plus and AT Design software. The team members electronically transferred data, including engineering drawings and electronic mail, through the computer network on a regular basis. In addition, weekly three-way video conferences were used to manage the PRT's milestones and activities.

The virtual collocation of the PRT significantly mitigated the typical limitations associated with widely distributed teams. The PRT met its challenge of reducing product realization time by 50%. The team also achieved a 50% reduction in cost from concept to first production unit and eliminated the need for a prototype product. In addition, virtual collocation successfully maintained team cohesiveness, reduced travel costs, and created an agile environment since teaming was not restricted to on-site individuals.

## CONCEPT STUDIES AND ANALYSIS

### Integrated Development Environment and Assistant Program

Sandia is developing an Integrated Development Environment and Assistant (IDEA) program that will provide easy and guided access to electronically accessible knowledge, information, and tools in an integrated development environment. IDEA will help personnel avoid duplicative efforts, inadequate scheduling, and continuation of inappropriate conventions. Information available will include relevant past projects, lessons learned, processes, standards,

guidelines, tools, and corporate and industry documentation.

IDEA currently provides an electronic facility for access to general Internet resources and to much of Sandia's unclassified information and knowledge such as project files, lessons learned, administrative and technical processes, corporate documentation, and product line resources. For example, IDEA allows the user to view and navigate archived project files developed in a particular tool even if the user does not have a copy of that tool. IDEA also offers an assistant guide to the user to those resources that are relevant to the user's needs.

When fully developed, IDEA will also provide a complete integrated development environment with a smarter assistant. Integration of tools, information, and expertise enhance IDEA's applications. For example, IDEA can help instruct a user to author a requirements document by bringing up the word processor of choice with a template to aid the user in developing that document.

Users will be able to connect to IDEA via Internet or modem from most PC, Macintosh, or UNIX workstation platforms. From IDEA, users may access resources originally developed on PC, Macintosh, and UNIX workstation platforms. The TIE-In (Figure 3-5) will provide a front end platform that will accommodate others such as DOD, DOE, external (U.S. industry) and internal (Sandia) access to IDEA. IDEA is scheduled for implementation at Sandia in March of 1995 and to others by the end of 1995.

Through IDEA, laboratories, universities, and U.S. industry can share knowledge, information, and tools, thereby enhancing technology transfer, fostering partnerships, and benefitting small businesses who could not otherwise afford to conduct research on this scale. IDEA will also provide an enhanced vehicle for stockpile stewardship.

### Optical Studies of Diesel Fuel Combustion

Sandia National Laboratories partnered with Cummins Engine Company to construct a more accurate model of the

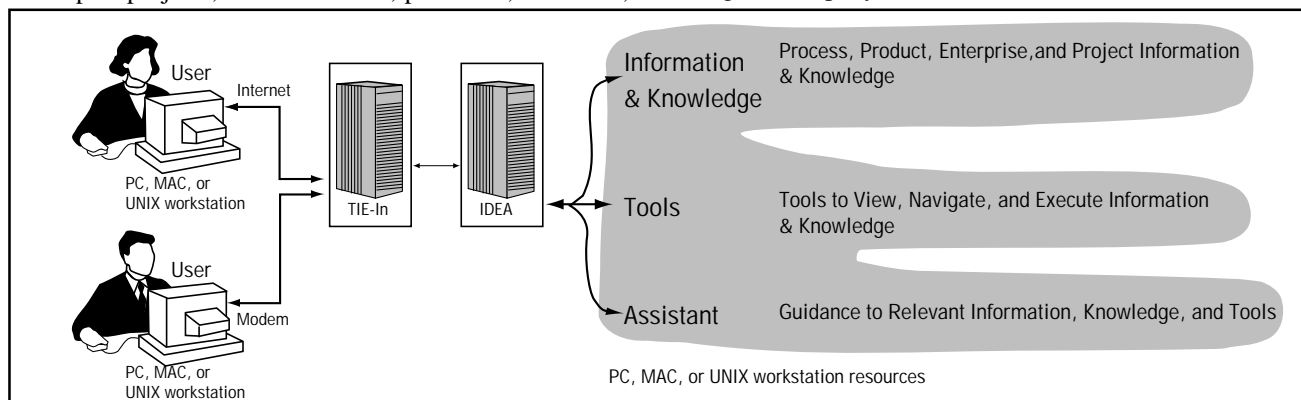
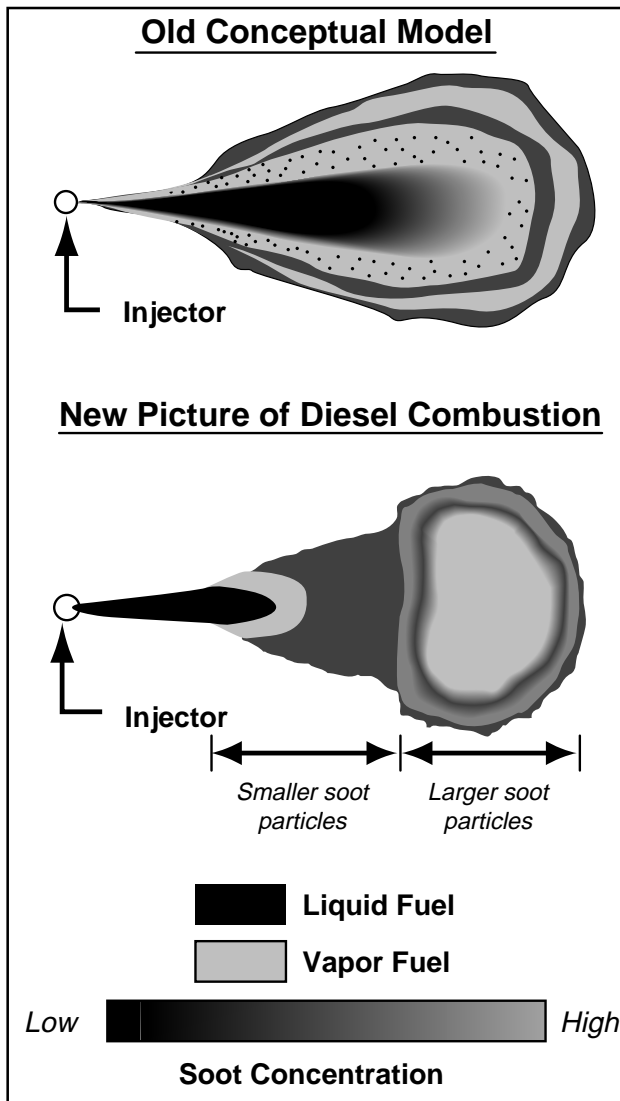

FIGURE 3-5. TIE-IN TO IDEA

dynamics occurring during diesel engine combustion in response to a need by American diesel engine manufacturers to develop a clean, efficient diesel engine without reducing performance or reliability. Sandia designed and built an optically accessible engine that retained the basic geometry of a production, heavy-duty diesel engine. Optical portholes on the engine enabled Sandia researchers to direct a two-dimensional laser sheet into the combustion chamber and quantitatively measure fuel-vapor concentrations and relative soot particle distributions.

The results showed that diesel combustion and soot particle formation proceed in a completely different manner from what was previously believed. The diesel engine design community believed that the liquid-phase fuel jet penetrated far into the combustion chamber and that both



**FIGURE 3-6. DIESEL ENGINE COMBUSTION (OLD VS. NEW)**

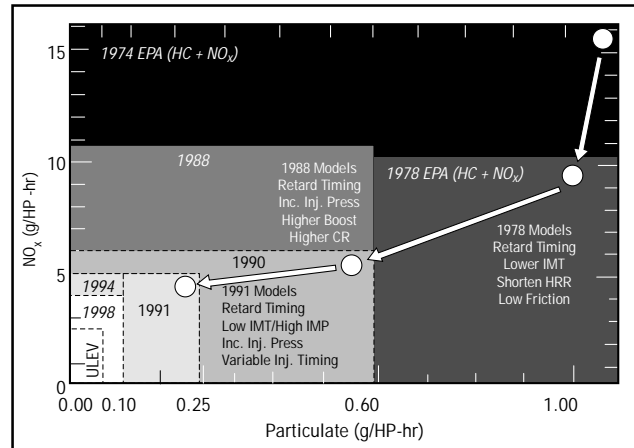

**FIGURE 3-7. EVOLUTION OF DIESEL ENGINE EMISSION CONTROL**

liquid and vapor-fuel were present in the combustion zone. It was also believed that the combusting fuel jet consisted of a pure-fuel core with a diffusion flame around the periphery and that large soot particles formed on the fuel-rich side of the diffusion flame in a shell around the periphery (Figure 3-6). Tests showed that in fact, under typical conditions, all the liquid fuel has vaporized by 25 mm from the fuel injector and that the fuel in the main combustion zone was in the vapor phase. It was also determined that soot formation occurred throughout the cross section of the leading portion of the jet with a higher concentration, and larger soot particles toward the leading edge in the head vortex region (refer to Figure 3-6). This information and the results of other studies in the optically accessible diesel engine have contributed to the significant reduction in diesel emissions achieved by engine designers in recent years. From 1978 to 1994, particulate emissions have been reduced by a factor of 10, and the emissions of oxides of nitrogen have been reduced by a factor of 2 (Figure 3-7).

By successfully imaging the in-cylinder combustion process, through the application of planar laser Rayleigh scattering and laser-induced incandescence, results were obtained that directly contributed to the development of a more accurate model of diesel engine combustion. This new model gives diesel engine designers the ability to make more intelligent design decisions in their efforts to further reduce emissions and increase efficiency while maintaining performance and reliability at acceptable levels.

## PROTOTYPE DEVELOPMENT AND REVIEW

### Virtual Company

The SNL have established a virtual company with many of its suppliers to address problems associated

with manufacturing prototypes to print. The old method required communicating with suppliers by telephone and mailing hard copy drawings since the drawing was the product definition. This practice resulted in long turnaround times and increased the chance of errors because the geometry had to be recreated by the supplier to program their CNC equipment.

The virtual company concept has created a nationwide partnership with nearly 2400 suppliers (Figure 3-8). With no restrictions on the origin of the CAD files they use, these suppliers can now apply their in-house expertise and equipment to provide the necessary services required by Sandia. With electronic communications and downloading of CAD files created by Sandia when they build a prototype model, suppliers can program their equipment to manufacture the required parts.

Benefits obtained by applying this practice include a reduced turnaround time on electronic assembly fabrications from two weeks to two days. Mechanical part fabrication times have been reduced 5% to 40% by eliminating the need to re-create the part geometry for CNC programming. The use of electronic files as product definition has allowed early recognition and resolution of problems during the development/design cycle. Intangible benefits include unlimited access to engineering specifications and the promotion of two-way manufacturability communications between the supplier and the design engineer.

### 3.2 TEST

#### INTEGRATED TEST

##### Evaluation of High Resolution Digitizers

At SNL, a suite of tests has been developed to characterize high resolution digitizers by using coherence analysis. Previous analog-to-digital conversion was performed upon command from a computer program which associated a data sample with the time it was acquired. With new high resolution analog-to-digital conversion, timing is more critical. Special facilities and procedures for evaluating the performance of high resolution digitizers have been developed.

The primary use of these digitizers is to process the signals produced in earth motion when an underground nuclear test is performed (typically in violation of treaty). It is vitally important that these digitizers are capable of identifying a small signal, even if it occurs within a large signal (such as an earthquake). The usual method of characterizing a device such as this is to compare its output response to a known input signal. However in this case, signal generators capable of producing a signal pure enough to challenge the specifications of the highest resolution digitizers have only recently become available and are very expensive. In addition, they provide only tonal signals. Recognizing this, SNL

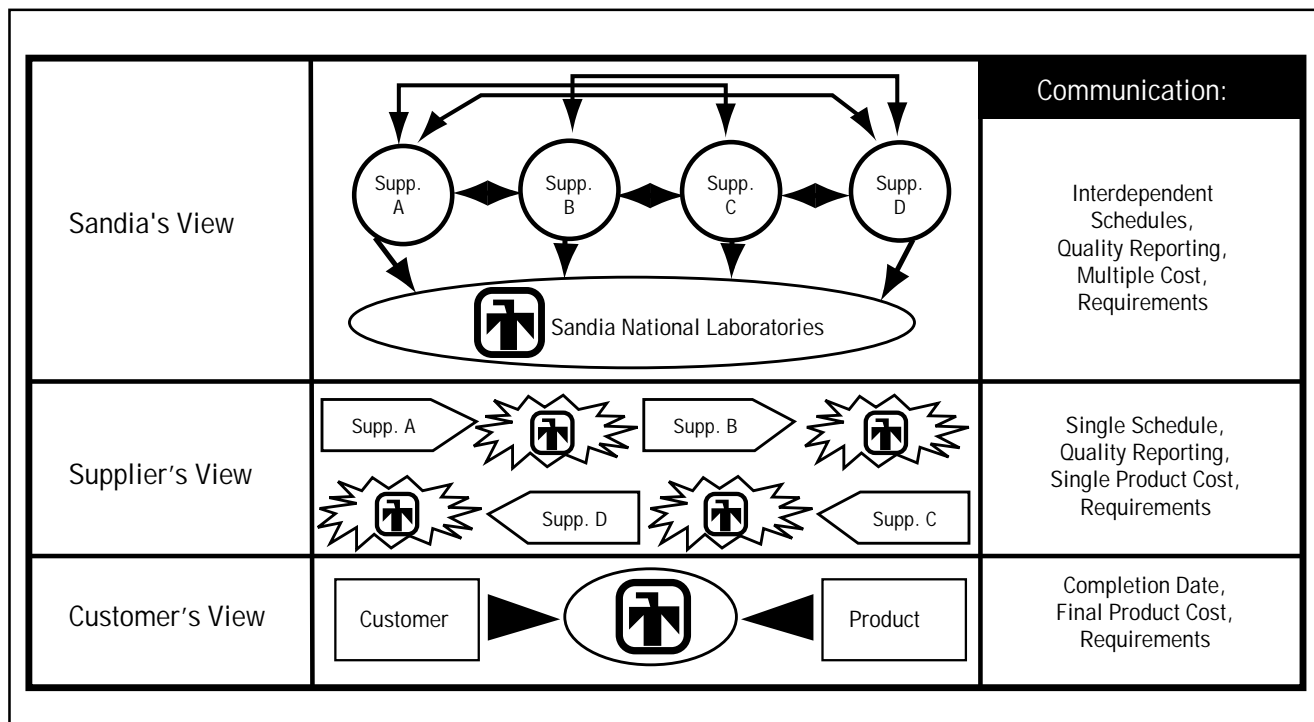

**FIGURE 3-8. VIRTUAL COMPANY INTERDEPENDENCE**

analyzed the parameters which are most important to characterize the digitizer and have determined that these parameters are primarily internal noise characteristics, linearity, dynamic range, and timing precision and accuracy. From this information, they developed tests to characterize the digitizers.

These tests include several data analysis procedures consisting of coherence analysis, Noise Power Ratio testing, Total Harmonic Distortion testing, and other straightforward tests such as AC and DC accuracy. Almost all these tests can be run “at temperature” to check for operation under actual deployment conditions or specifications. These tests provide a realistic estimation of expected performance of the high resolution digitizer in an environment where detection of small signals in the presence of large signals is important.

## SOFTWARE TEST

### Software Unit Testing

Sandia National Laboratories’ Surety Assessment Center developed a process guidebook to help improve past practices in software unit testing. Policy, techniques, standards, metrics, tools, and training are part of this process model (Figure 3-9).

Debugging software errors in system test was difficult and costly and many errors were not found until system test. However, using standard testing techniques on the individual functions or units, software errors could be detected early in development. Many software programmers had not been exposed to software unit testing, were reluctant to perform extra testing to a “good” program, and had not been required to show evidence as part of their work requirement. If unit testing was done, it was not forwarded to the customers, other programmers, or the system integrator. The system integrator would do unit testing in a system context, costing up to 100 times as much.

The new unit test process begins with establishing testable unit requirements from the software design documents. Testware design produces sampling and combining rules,

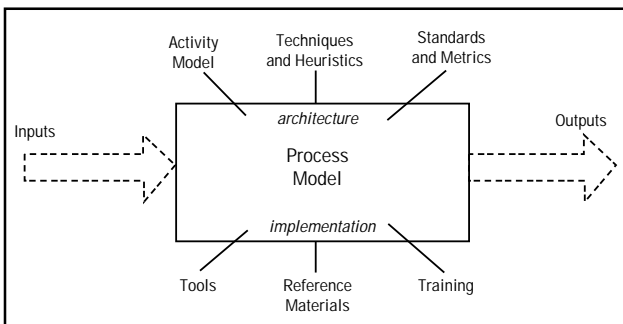

**FIGURE 3-9. SOFTWARE UNIT TESTING**

sample sets, transition sequence rules, sequence sets, test case descriptions, and test case sequences. Software design produces the data structures, functions, and domain definitions. Simple rules for choosing test cases generate test scripts which can be applied to the unit through a testware driver and stubs. The test case catalog traces test cases to the unit’s requirements, and the test results give repeatable pass/fail indications and a measure of testing comprehensiveness. The test execution framework is simple C language source code, completely isolating the software unit under test. The unit software to be tested does not need any simple “hooks” inserted to enable automated testing.

Designing for testability creates modular software with clearly defined interfaces. Regression testing of the unit software ensures code integrity. The unit testing process at Sandia helps developers to perform effective unit testing. The process reports what is known about each units’ behavior, guaranteeing the system integrator of proven capabilities.

## 3.3 PRODUCTION

### QUALIFY MANUFACTURING PROCESS

#### Process Characterization Methodology

Process Characterization Methodology (PCM) at Sandia facilitates Product Development Teams to systematically transition a product from design to efficient and controlled manufacturing processes. PCM provides a means to detect and address potential processing or design-related problems and utilizes several industry tools such as risk assessment, statistical process controls, and Ishikawa Diagrams.

Prior to the development of PCM, product development was poorly focused and lacked concurrent engineering. There was poor correlation between manufacturing, design, and customer requirements. Manufacturing and product field problems resulted from inadequate processing.

With PCM, a system is in place to provide a systematic transition from design to production. The four stages involved in PCM include develop and screen processes, critical-process characterization, process capability studies, and optimization and control. These four stages allow a user to focus resources on critical process issues.

Users develop a process flow chart to lay out the manufacturing sequences. In this flow chart, operations are represented by process nodes which initially represent a major step in the manufacturing processes such as fabrication, assembly or testing. The process continues by the team identifying the critical processes, and a ranking process is applied from which team averages are determined using the risk assessment matrix.

---

The PCM is flexible as it can be tailored to project needs. It is a bottoms-up process analysis and complements other industry approaches such as Reliability Fault Tree Analysis or QFD. The methodology reduces the likelihood of production problems and provides a decision base for making process changes when needed.

PCM has been implemented on several projects since initial development three years ago. Future plans include the use of training courses for users of the methodology and the development of a software/database package incorporating the process.

## **DEFECT CONTROL**

### **Cable Tester**

SNL's Electronic Fabrication Department used a manually operated megohmmeter-based continuity and highpot tester to evaluate cables. In 1986, the need to improve the inherently slow operator-controlled system was recognized, and the SE3262 Cable Tester was developed and finally implemented in 1988.

The SE3262 tester consists of commercially available equipment including IEEE-488 controlled power supplies, multimeters, and scanners. The scanner's relays provide a matrix to provide the connection paths for the desired measurements under IEEE-488 control. Simple continuity and isolation tests up to 500 Volts as well as accurate four-wire resistance tests can be performed from the menu-driven computer screen. One hundred wire cable assemblies can be tested at a time, and a larger number of assemblies can be tested by breaking the tests into smaller groups. The accurate resistance measurements can be used to verify the gauge of the wire in the cable.

A library of over 700 interface adapters has been developed to interface with each different connector type. Building an additional interface requires only a spare connector from the customer and is easily constructed.

The significance of the SE3262 Cable Tester is the flexibility of the test configurations and ease of use. For a large number of simple cables, a local contractor is used to lower costs. A similar tester is being developed to allow isolation tests up to 1000 volts. The cost for both testers is approximately \$300K.

### **Low Volume Statistical Process Control**

Sandia is developing low volume statistical process control (LVSPC) to apply to its small quantity of products produced. The method used to evaluate the process involves an algorithm which updates the estimate of a time-varying mean whenever more data becomes available. This type of estimate is more effective than the

usual sample average when the process mean varies over time.

The model used for low-volume production is an extension of the classical Shewhart approach which models the process mean as varying over time, and leads to an estimate of the current mean weighted to the most recent data. Two types of control charts with increased sensitivity for LVSPC include the cumulative sum and exponential weighted moving average methods. These charts use information from the entire sequence of available data points with points nearest to the current point weighted to have the greatest effect on the process mean. Additional work with these models has been used to determine the number of points necessary to achieve statistical validity. This number is based on the process parameters and the amount of noise and variation of noise in a particular process.

Sandia is working to establish an applicable SPC tool when data is limited. Theoretical statistical research with some limited production for validation has aided in developing methods for LVSPC. Integration of new and traditional SPC methods with adaptive filters is providing new and improving tools for low volume process controls. LVSPC will prove beneficial to industry as industry becomes more agile and moves towards smaller product quantities. Useful and accurate LVSPC techniques are needed because of the scarcity of process data in low volume production.

## **TOOL PLANNING**

### **Solid Model/CNC Programming**

The Sandia National Laboratories instituted CNC programming to help integrate product design and manufacturing. Previously, the product was designed by the engineering department, and the design was "thrown over the wall" to the manufacturing department to make the product. The CNC programming section would create the CNC code using a language-based, automatic programmed tools language after re-creating the part geometry, perform separate verification techniques using plotters and VERICUT simulation packages, and then dry-run the program on the machine tool. This process was time consuming, expensive, and created many chances for errors in the re-creation of the part geometry.

CNC programming personnel could use the solid model database available through ProEngineer, thereby eliminating the need to re-create the geometry. Using electronic data file transfer, the original design could be sent directly to the CNC programming section for creation of the code to manufacture the product. This process also allowed the conceptual designer or engineer and the CNC programmer to examine manufacturability issues early in the process and resolve the issues before the design was committed.

Through the sharing of a common solid model, one to 20 hours per CNC program is normally saved by not reconstructing part geometry; hard copy drawings are no longer required; rapid visualization of part features is obtained; associativity (many applications sharing the same database) is realized; and more complex parts can be programmed more quickly with fewer errors.

## COMPUTER-AIDED MANUFACTURING

### An Expert System to Support Green Design and Manufacturing

Sandia has developed EcoSys™, an information system and expert system for demonstration of environmental impact analyses of product designs and processes (Figure 3-10). SNL recognizes that green design is an integral component of an ideal product realization process. Unfortunately, the assessment of tradeoffs between the environmental attributes associated with competing processes or products is extremely challenging, particularly due to many technical, societal, and cultural perspectives associated with environmental quality. To enable emerging concurrent design and agile manufacturing initiatives at both corporate and national levels, a methodology for green design that incorporates these perspectives and provides timely design information and decision support is critical.

Accessible electronically, EcoSys™ is an enabling technology for the design-for-environment community. Through rule-based search algorithms, the expert system represents the explicit interdependencies between products, processes, and materials. EcoSys™ provides designers and process engineers with unique perspectives regarding the relative environmental impact be-

tween a set of alternate designs. Impact analysis models provide environmental assessments at various levels of environmental consciousness. The information system is host to detailed life cycle product, process, and material data that are critical to the analysis. Cost-effective assessment of the environmental impacts of products can be performed despite the trend toward increasing product complexity.

First delivered in October, 1993, the EcoSys™ prototype has been the subject of peer review and has since been extended to permit real-time definition of alternate product structures. While the initial prototype system was designed to support assessments of electronic assemblies and associated processes, the EcoSys™ framework will support assessments of a broad range of product and process types. Sandia is actively seeking partners to collaborate in refining EcoSys™ and extending the system's application to a variety of industries.

### A-PRIMED Robotic Workcell

A robotic workcell has been designed and built at Sandia to perform manufacturing validation tests for A-PRIMED discriminator devices and to assemble these devices in low volumes. The robot in the workcell is controlled by code generated at Sandia using automated assembly programming capabilities.

This currently portable workcell incorporates a unique, modified hexagonal aluminum design built on a statically determinate, three-point steel support structure. This structure allows the cell to be easily integratable, lightweight, and to occupy minimal floor space. The workcell accommodates variation of the robot height, overhead lighting arrangement, and cameras. Future plans include mounting the

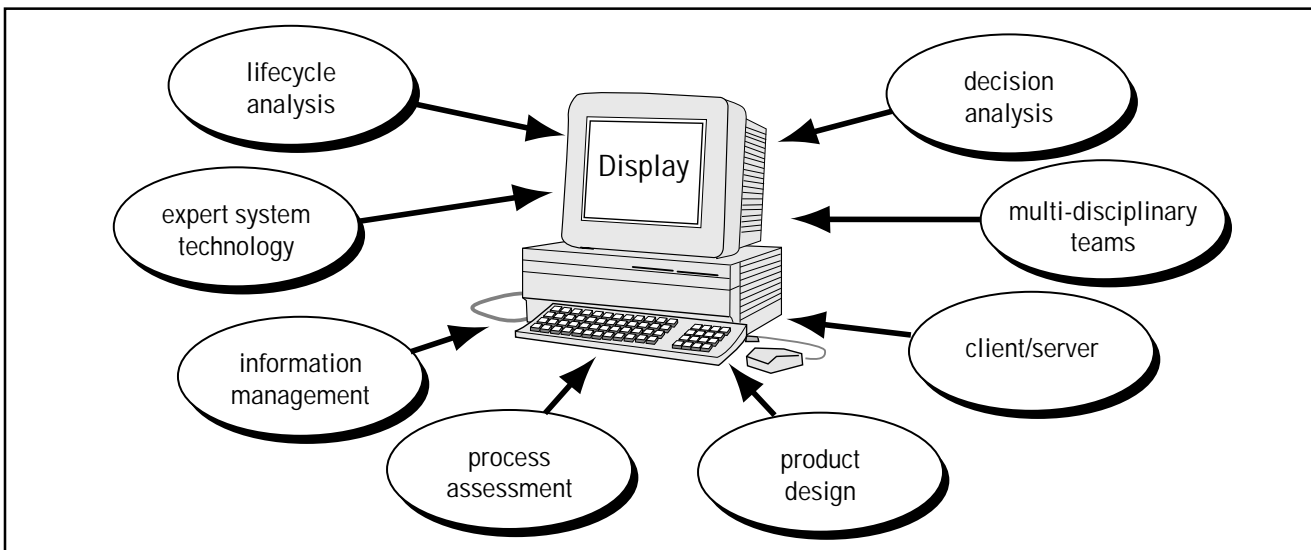

FIGURE 3-10. THE EcoSys™ FRAMEWORK COMPONENTS



robot to a separate base to determine the possible effects of vibration on the robotic cell.

The x-y-z carriage is utilized to position a laser head to spot weld the gear on the shaft of the discriminator. The cell includes a Class 4 laser that, with enclosures, is reduced to a Class 1 laser. The laser welder is outside the robotic working space radius and parts are transferred from the robot to the laser by a pivoting tray. A camera-controlled vision system controls the movement of the robot, and with the addition of corrections to this system, the robot is accurate to within 0.002-inch.

This system is an integral part of the A-PRIMED Project as one of the intelligent machines that form the core of agile production technology.

### Engraving Complex Layouts Directly from CAD Files

The Electronic Fabrication Department at SNL can take CAD data files produced on various platforms throughout the facility and convert them into CAM programs for CNC engraving machine operations. Using the internal LAN, design engineers send CAD data directly to the department. This data is converted into the necessary program required to operate the engraving machines. Although most files transferred are primarily character font-based data, any standard plotter outputs can be received and converted into engraveable symbols. Graphic symbols and images such as electronic panel layouts can be created at the design engineer's workstation and electronically mailed or downloaded to the fabrication department workstation. The data is then converted and translated to produce an engraved part.

This electronic communication of CAD data provides immediate feedback to the design engineer as to the feasibility of the design, as well as providing the ability to view any alterations that may be required to produce the desired part. Unlike previous standard engraving machines that relied on templates, the CNC machines used at SNL can reproduce graphic images and text in a variety of fonts and sizes.

### Automated Cleaning of Electronic Components

Because of high reliability requirements of their products, the SNL pay particular attention to all manufacturing process steps that could impact that reliability, including cleaning. It is imperative that all assembly residues, especially potential long-term corrosives such as skin oils and flux, be completely removed. Since many SNL designs use leadless devices that allow very little space between the component and the printed wiring board, cleaning poses an exceptional challenge. The Intelligent Systems and Robotics Center, in conjunction with the Kansas City manufacturing facility, have

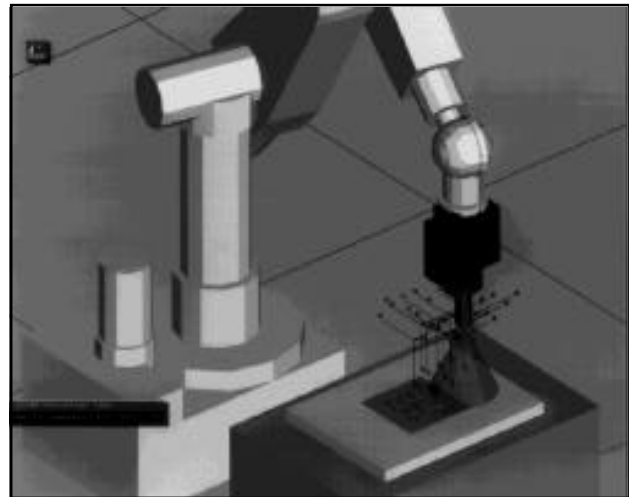

**FIGURE 3-11. SIMULATION OF ROBOTIC SPRAY WORKCELL**

developed an automated workcell approach to this cleaning issue.

Because chlorofluorocarbon cleaning materials are no longer permitted, the facility is investigating aqueous cleaning materials, and current cleaning processes in the production facility are mostly manual. This combination has created a lack of precision and lack of control in the cleaning process, as well as excessive cleaning time and solvent usage. In addition, because of the long cleaning cycles and new processes, operators experience a great deal of fatigue and uncertainty. The necessary process control is difficult to establish and maintain.

Therefore, the SNL have developed an automated workcell for cleaning electronic components which uses aqueous microdroplet spray technology (Figure 3-11). CAD data is input into the system which generates a solid model of the printed wiring assembly. Then, using rule-based process knowledge integration, a spray pattern is generated and utilized in the cleaning process. The system then automatically completes a wash, rinse, dry cycle.

By implementing this process, the SNL expect that spray control will be improved by increased repeatability and precision control. The automated method could also generate an audit trail for the product processed as well as how it was processed. Cleaning quality will be improved, and handling and cleaning required will be reduced. Future plans include construction of a robotic cleaning system capable of processing using flammable solvents such as d-limonene and isopropyl alcohol.

### Automated Assembly Planning

Sandia National Laboratories are currently working on an automated assembly planning tool as part of the A-PRIMED

project. This tool will utilize simulation software that can immediately illustrate the assembly process to include parts interactions and would be valuable for both manual and robotic applications. For the robotic application, this software includes the necessary task planning and plan translations to prepare a detailed device-specific robotic program.

This planning tool development is the result of the complexity and diversity of many modern products. Additionally, these products are being designed at faster rates than before, and packed into smaller volumes with lower costs than previously attainable. This results in more complex assembly plans which lend themselves to automation.

A computer-aided planning method helps ensure process compatibility and ease of component assembly. Designer's assembly plans can also be checked to avoid costly mistakes in both design-for-manufacturing and design-for-assembly areas. This should result in a reduced product development cycle through automation of the production planning process.

To develop this tool, Sandia chose the A-PRIMED demonstration product called a "discriminator," a precision electromechanical device used as a safety switch. During this project, process plans for the discriminator were developed and simulated using a CAD system. Dimensional and positional considerations were the initial focus of this effort. A demonstration test cell is currently under construction and follow-on simulation efforts will address fixturing and tolerancing.

Once fully developed, this technology could become one of the many useful tools which Sandia can include in its engineering toolbox via the AMTnet.

## SUBCONTRACTOR CONTROL

### Two-Phase Supplier Selection

Sandia National Laboratories underwent a two-phase selection process to establish a supplier of the H-1616 Tritium Reservoir Shipping Container. This was an iterative process where approximately 10% of the total quantity was procured from two suppliers during the first phase. The second phase was to award the remaining 90% to one of the two suppliers identified during phase one. If both suppliers demonstrated the same quality of service, then phase two was awarded to the lowest bidder.

Sandia went out with a Request for Quotation with a Statement of Work defining the iterative process of awarding 10% of the 2500 shipping containers to two contractors to be referred to as phase one. The Statement of Work also stated that at the successful completion of phase one, the remainder of the 2500 units would be competed again, only this time, between the two identified sources. The lowest bidder would be awarded the contract.

There were some added expenses in establishing two suppliers. To ensure equality to both sources, pre-award costs and

follow-on visits were necessary. This doubled travel costs. Because this two-phase process is a form of competition, SNL benefitted through cost savings, no schedule changes, and an established second supplier.

Management felt there was a need to establish more than one source for the H-1616 and, because of an immediate need, decided to use this two-phase selection process. The traditional procurement process did not allow them to establish a second contractor with proven ability. Through two-phase competitions, Sandia National Laboratories has been able to identify both a primary and back-up supplier.

## 3.4 FACILITIES

### MODERNIZATION

#### Shielded Plasma Cleaning for Package Assembly

In response to the elimination of ozone depleting solvent use and in an effort to improve the quality and reliability of their microcircuits manufactured on site, SNL has instituted a change in the cleaning process for microcircuits. Manufacture of microcircuits requires cleaning prior to die attach, before wire bonding, before hermetic sealing, and after soldering. This cleaning process removes contamination caused by outgassing and bleedout of epoxy used in bonding processes, contamination from photoresist, humans, and air from poor storage conditions. Traditionally, these cleaning processes have been accomplished using freon vapor degreasing.

A traditional replacement for the freon degreasing process is one using plasma barrel chambers. The unique plasma process at SNL employs a downstream process rather than the traditional barrel chambers. Downstream or shielded processing generates plasma in one part of the chamber, then flows the excited but neutral component of the plasma down to the part to accomplish the atomic cleaning (Figure 3-12). Hence, the circuits and packages are not immersed in the plasma with its

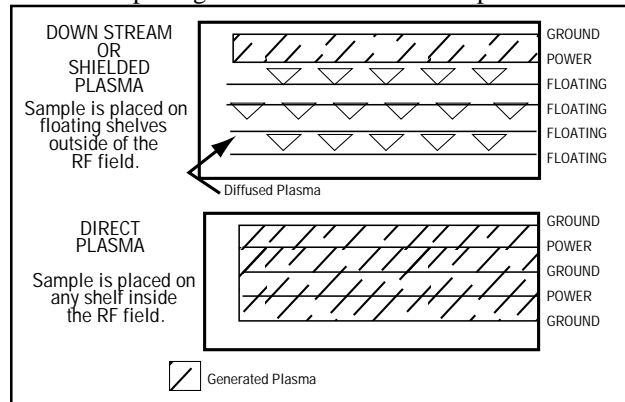

**FIGURE 3-12. DOWNSTREAM OR SHIELDED PLASMA PROCESS AND DIRECT PLASMA PROCESS**

high frequency oscillating electromagnetic fields of positive and negative charged particles.

This process has provided for increased wire bondability of difficult to bond surfaces, improved wire bond quality and reliability, elimination of plasma induced circuit damage, elimination of one more ozone depleting solvent (freon), and pollution prevention and waste minimization.

Additional research into the benefits of using a downstream plasma cleaner is being conducted by SNL. Sandia maintains that this research will lead to even higher reliability of micro-circuits and drive down some of the associated manufacturing cost.

## Manufacturing Prototyping Facility

In October 1993, the SNL facility at Livermore, CA established an Integrated Manufacturing Prototyping Facility to support prototyping and integrating advanced manufacturing technologies (Figure 3-13). This 90,000 square foot facility was built with flexible reconfiguration as its prime objective. The design allows most inside and outside walls to be modified with minimum construction delays. There are large open areas with no floor or ceiling obstructions for ease of equipment layout and movement. There are both high and low bay areas for either laboratory or manufacturing demonstration facilities. The low bays have access to the roof areas where all electrical and air handling services are located. This design allows for flexibility in locating machine tools and exhaust services anywhere within the facility. All areas of the facility have access to the fiber optic communication system.

Six fiber optical pairs are routed to each work area with a multiplexer system for easy access and routing between three different communications networks at Livermore. Areas within the facility are equipped with coded personnel access controls to restrict or permit entry through a central site computer system.

This facility was designed and built to support the integrated systems approach to manufacturing technology development. It has the capability to rapidly respond to changing customer and program requirements in real time. Unlike traditional facilities with compartmentalized capabilities with fixed hard-wired equipment and infrastructures of isolated organizations, this facility provides the capability to integrate interdisciplinary teams in a common area for problem solving and collaboration on projects.

Since the facility opened in 1993, the SNL have added three new customers to their customer sponsor base and are recognized as a model facility for manufacturing technology integration by DOE. They have reduced their response time for installing and qualifying equipment by 50% and have attracted world-class researchers and technologists with a two-fold increase in the PhD level in the manufacturing engineering staff.

## FACTORY IMPROVEMENTS

### Preventive Maintenance

The SNL upgraded their preventive maintenance effort through the installation of a PC-based preventive maintenance program. Maintenance records were previously kept on a mainframe computer using SNL-developed software. The computer, which was labor-intensive to maintain, did not allow SNL to track maintenance costs effectively, did not have user definable maintenance scheduling capability, and did not contain maintenance procedures as part of the database.

In early 1994, SNL purchased commercial maintenance software from Datasystem Inc. of Greenville, SC, facilitating a change to a PC-based system that was more cost effective, permitted local shop control, and was integrated. This new integrated system supports maintenance scheduling, has specific/tailored maintenance instructions, and



**FIGURE 3-13. SANDIA/CALIFORNIA MANUFACTURING PROTOTYPING FACILITY**

---

gives a history of maintenance activity. In addition, maintenance hours records can be maintained and queried, and reporting capabilities are available. SNL can now optimize the use of their maintenance staff and further reduce cost.

While the full benefits of this change to a PC-based system have not yet been realized, Sandia has made significant improvements in maintenance processes. Among the benefits derived are:

- Maintenance database developed for 735 machines
- Eliminated reliance on VAX computer
- Replaced custom software with commercial software which has saved the Full Time Equivalent of 0.1 computer analyst time
- Scheduled maintenance for 330 machines
- Optimized the use of maintenance personnel.

## Sandia Voice Information System

Sandia's Voice Information System (SVIS) uses voice information throughout the lab as an enabling technology for productivity enhancement providing voice mail, faxing, information delivery, interactive voice response (IVR), and other information connections. SVIS enables better use of time and talents of Sandia personnel while providing extended hours and better service for users.

SVIS was developed out of a need for more efficient and effective communication. Too many messages were not received or delayed due to lack of enough people to provide support. Support staff personnel spent most of their time answering phone queries, processing forms and paperwork, and moving paper. A real need existed to leverage existing staff to provide better operational support. Sandia considered purchasing automated systems and opted to develop a system internally using an Octel system.

The system has many features and capabilities and is continuously improving. Voice mail complements e-mail and allows travelers to keep in touch 24 hours a day. Savings with voice mail alone which handles a volume of over 400,000 messages a month is estimated to be equivalent to more than 50 full time employees. Faxing is available on voice mail. This allows users to receive and print faxes when and where desired and callers' faxes always get through on the first call. As a result, fewer fax machines are needed and service is better.

Because telephones are readily available to everyone no matter where they are located, a service called "Sandia Line" was developed to leverage the investment in the voice mail system and provide additional services. This capability allows current and former employees worldwide to get information by phone or fax. This

information includes benefit rules and forms, personnel information, educational offerings and forms, procurement information, schedules, and much more. IVR applications are used for accessing corporate information. The Job Vacancy line is used by all employees to learn about and make bids on job offerings. The invoice status line is used by 12,000 vendors to electronically check the status of invoices and payments. The Benefits Open Enrollment period is also managed by an IVR application. Employees can check the status of their purchasing requests, change their telephone numbers on the corporate database, register for classes, and do many other tasks quickly and conveniently without losing time from work and taking the time of support staff. The system is easy to use with new capabilities being added continuously. In the future, employees will be able to check their personal accounts, get travel policy information, and access certain information in their payroll profile. Currently more than 7500 calls are taken by IVR alone each month.

Sandia has used voice mail to greatly enhance its worldwide communications capability. IVR and associated delivery techniques have leveraged the investment in voice mail equipment. The system gives employees flexibility to achieve the best use of their time and allows support personnel to help customers. Considerable savings have been achieved while providing superior service.

## Nuclear Waste Management Program Administrative Information Management System

The Administrative Information Management System (AIMS) is an integrated network of databases which function to provide project management information to technical projects within the Nuclear Waste Management Program. Historically, databases existed in stovepipe standalone systems with no central architecture design to incorporate resources. What existed before was multiple stand alone databases and multiple database products. System design and requirement assessments were started in 1988, and the current system uses relational databases containing records, training, controlled documents, technical report tracking/references, work breakdown structure, and quality assurance programs. Integration of the data files is accomplished through a common link to a personal database, which ensures that staff demographics referenced in each database are current and in a consistent format.

AIMS has enabled timely retrieval of information for management decision support, as well as provided a mechanism by which projects can control compliance with customer requirements and respond rapidly to customer information. Features and benefits are:

- Improved communication/maintenance of administrative information.
- Compliance with regulatory/licensing reporting requirements
- Reduction of data redundancies, inconsistencies, gaps, and
- Increased reporting flexibility and response time to service customers.

Changes were implemented using Informix RDMS and a SUN Unix Platform. Connectivity was installed and implemented to all customer organizations to ensure effective communication. Several customers are being represented and are end users of the AIMS. Benefits obtained to date include higher quality of information management, increased support of customer requirements, as well as support for audits and surveillances. Management now has capabilities to use performance metrics and has reduced staff impacts for greater productivity.

## FIELD VISIT/SITE SURVEYS

### Benchmarking for Waste Minimization Project

The Department of Energy was ordered to reduce 50% of its hazardous waste streams by the year 2000, and executive orders were issued stressing source reduction and purchase of recycled products. SNL was funded to investigate waste minimization options. After finding that information on waste minimization was not readily available to specific generators of DOE waste, Sandia concluded that a benchmarking project needed to be implemented to obtain meaningful information on the best practices available.

This benchmarking program was conducted in four major phases (Figure 3-14):

1. **Planning phase.** SNL established a commitment from management, identified manageable processes, and built a team of experts in the processes of interest.
2. **Collection phase.** The chosen processes were studied by DOE-wide team members, and metrics were collected to provide points of contrast between before and after. Potential partners were identified and contacted to collect suitability information. Two partners were selected for each waste stream being benchmarked.
3. **Analyze phase.** SNL and the benchmarking team conducted site visits and interviewed the selected partners. The interview information was analyzed and a report was prepared.
4. **Adapt phase.** The report provides information that DOE sites can use to modify their waste minimization

practices in their own organization. The waste generators are encouraged to continue the benchmarking process by continual improvement of their processes.

As a direct result of this benchmarking, savings of \$100K in disposal costs at one DOE site have been realized. SNL believes that benchmarking is versatile, adaptable to any organization, and is a cost-effective way to introduce new information into an organization.

## 3.5 LOGISTICS

### TECHNICAL MANUALS

#### Computer-Aided Acquisition and Logistics Support Operational Network

Over an 18-month period, an SNL Process Quality Management and Improvement Team developed a Computer-Aided Acquisition and Logistics Support Operational Network (CALSON) Process to streamline nuclear weapon maintenance manual generation. When the team was assembled in July 1992, it was immediately determined there were areas of the process that could be significantly improved. These existing processes had been in place and unchanged for years, and all systems relied on paper transfer of data. In addition, none of the processes was integrated. Design data had to be copied in pen and ink to create illustrations for the manuals, and text, created on a word processor, had to be manually laid out with illustrations and callouts. Editing was even more labor intensive.

Recommendations from the team focused on producing documents that would be compliant with the CALS standards developed by DOD. These standards define

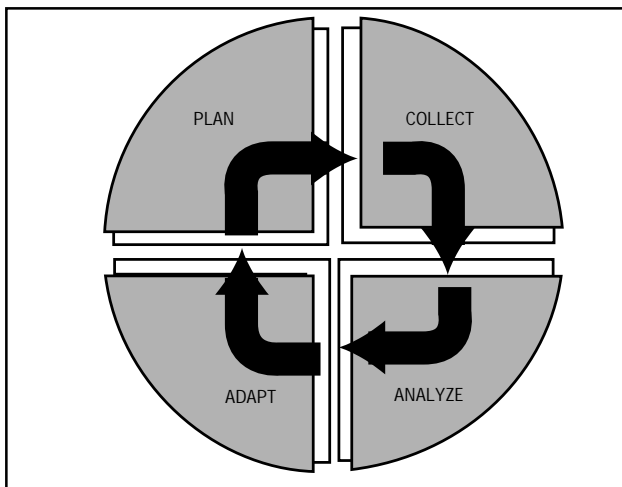

FIGURE 3-14. BENCHMARKING PROCESS

the requirements and overall rules for organizing files of digital data; subsets of the Initial Graphics Exchange Specifications for technical illustrations, engineering drawings, electronic/electrical applications and manufacturing; Standard Generalized Markup Language for source data and composition processing; International Consultative Committee on Telegraphy and Telephony Group 4 compression for raster graphics; and Computer Graphics Metafile for two-dimensional vector illustrations.

To be completely effective, the team's plan must impact the design process as well. The two-dimensional Anvil 5000 CAD system used by the designers needs to be replaced by three-dimensional ProEngineer CAD systems to accommodate illustration views being rotated and transported to illustration CAD machines. Networking has to also be created to support the integration, and compatible illustration and word processing software needs to be integrated into the system.

All required tools to accomplish this plan were available, off-the-shelf products. In March 1994, the plan was submitted and funded, and the system is now becoming operational. The first manual was recently produced on the new integrated network. Preliminary data indicates the new process will save \$950K per year and will decrease the time required to produce maintenance manuals by two-thirds. The CALS compliant formats produced will also support the migration of these documents to the new electronic book technologies of the future.

### 3.6 MANAGEMENT

#### MANUFACTURING STRATEGY

##### Electrical Seamless Manufacturing Team

In mid-1990, Sandia National Laboratories/California formed an Electrical Seamless Manufacturing Team in response to several issues requiring improvement. Its PWB process was suffering from quality problems and was inefficient; standard CAD tools were not in use; there were very few automated programs; and there was a general lack of understanding of the PWB design-to-manufacturing process. Sandia believed the team could help personnel address these issues as well as learn how to better serve their customers by focusing on issues associated with optimizing the PWB process.

SNL/California formed a cross-functional team with a customer-supplier relationship. Team members were from engineering, design definition, computer-aided engineering, computer-aided manufacturing, and electronic fabrication. The team's focus was to 1) develop efficient, high quality processes based on the customers'

needs; 2) define processes for each discipline; 3) develop seamless interfaces between each discipline; and 4) develop metrics to support continuous improvement.

The team has had an impact. As a result of its efforts, there has been improved communication between customer and supplier. Processes are better defined, and a set of guidelines for design for manufacturability has been developed, as well as a standard component library. An automated program is in place to create a consistent set of manufacturing files for fabrication services such as photoplot data, drill, and test. A process has been created for feedback leading to continuous improvement.

The team is currently revisiting the process to incorporate changes required for the new standard PWB design software also used by SNL/New Mexico and the Allied Signal/Kansas City Division. The team determined that characteristics developed using the previous software are still required and need to be implemented.

#### Technologies Enabling Agile Manufacturing

Technologies Enabling Agile Manufacturing (TEAM) was formed to deploy integrated, validated design-to-manufacture tools and to identify processes that streamline product development, reduce costs, enhance quality, and shorten cycle time. TEAM leverages the technology strengths of industry and government to support a national agenda to insure the global competitiveness of the U.S. industrial base.

TEAM is comprised of five DOE labs and plants, more than 20 individual industry members, industry consortia, academia, National Institute of Standards and Technology, Advanced Research Projects Agency, National Science Foundation, Agile Manufacturing Enterprise Forum, and Society of Manufacturing Engineers. TEAM's organizational direction is provided by an industry-led steering board, with technical progress led by both industry and government thrust area teams (Figure 3-15).

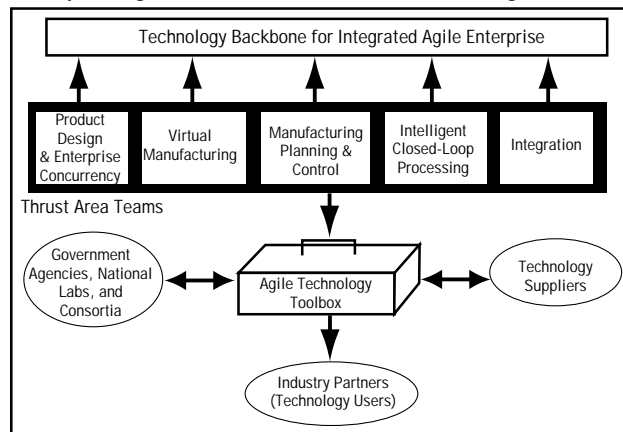
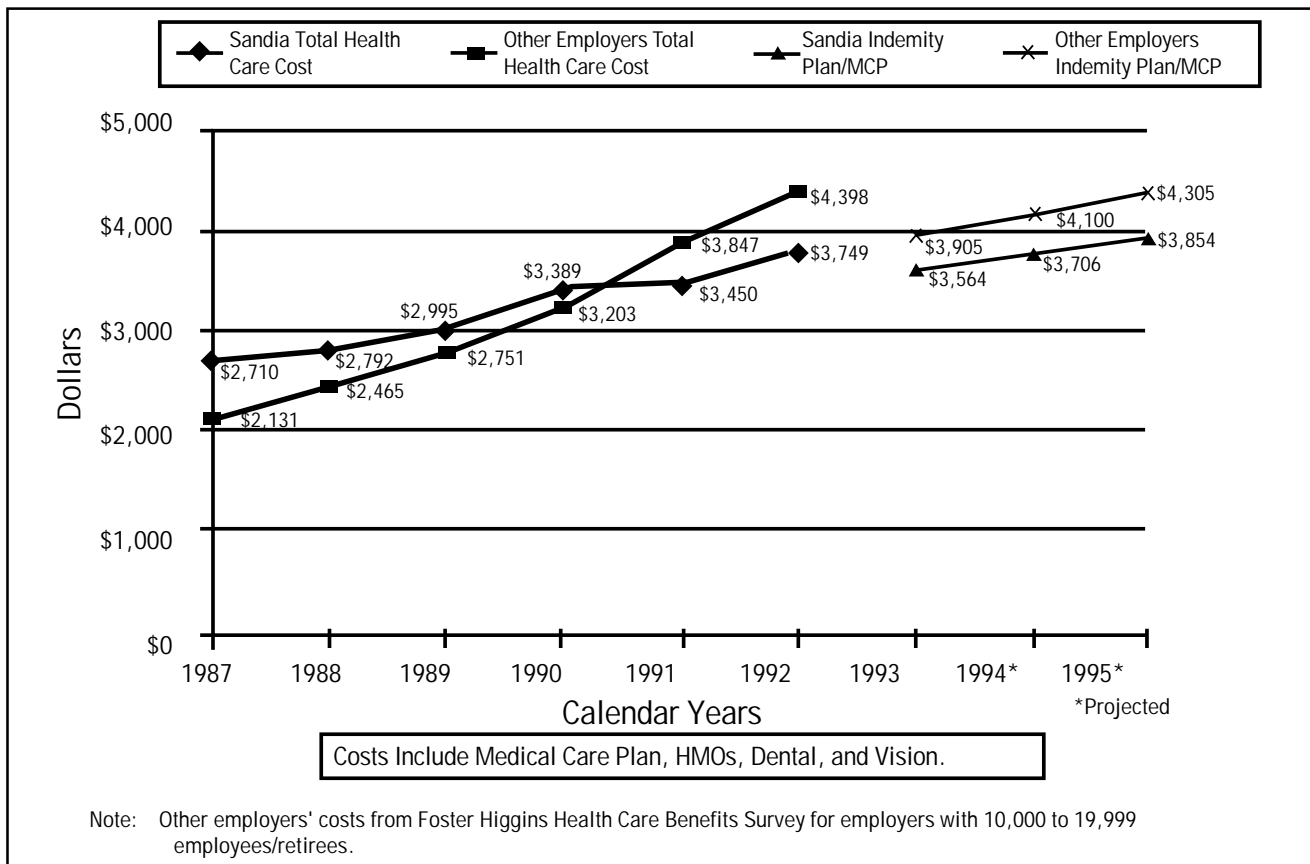

FIGURE 3-15. TEAM CONCEPT



**FIGURE 3-16. SNL HEALTH CARE COST VS. OTHER EMPLOYERS**

TEAM focuses on all the elements of the product realization process through a diverse portfolio of thrust areas such as product design and enterprise concurrency, virtual manufacturing, manufacturing planning and control, intelligent, closed-loop machining, and enterprise integration. Initial technology demonstration areas for these thrusts include material removal, sheetmetal forming, and electronic/electromechanical assembly.

The benefits of TEAM will be realized through the successful deployment of robust, flexible, modular tools that are readily accessible and implementable, and demonstrated in a distributed environment.

## PERSONNEL REQUIREMENTS

### Benefits Services

The Sandia Health Planning and Administration Department manages cost-effective products and services through a total integrated health care process. Metrics (Figure 3-16) have been collected over the past seven years and show that Sandian's health care cost increases continue to be lower than the national average. This is partially due to their integrated process.

Most large companies divide the responsibility of plan design and fiscal control from the administration and delivery. At SNL, the entire function of health benefits plans are housed in one working group. This group is responsible for the following processes:

- Plan design and development
- Procurement of third party administrators
- Financial planning and fiscal control
- Legal and regulatory review, compliance and reporting
- Employee communication and education
- Service provider interface and negotiation
- Administration/delivery

This integrated approach results in a customer oriented staff that understand the business requirements for managing SNL's health care costs while providing a competitive benefit package. The entire workforce of Sandia National Laboratories is covered under this fully integrated plan.

The medical plan includes three union organizations within the same plan as nonunion employees, and retirees. The number of individuals under the plan is roughly 23,000. The plan protects participants from major financial hardship and maximizes cost effectiveness of the dollars spent for medical care. The objective of the medical care plan is to

---

maintain access to quality medical care while managing escalating costs and meeting legal and legislative requirements. Implementation of this strategy occurred over several years.

Sandia National Laboratories has been able to respond to customer needs and exceed expectations in the medical care plan. Participants are provided cost effective alternatives and the quality of health care is not compromised.

## Processes Developed for Test and Evaluation

SNL drafted a plan to develop formal process developmental procedures (Figure 3-17) in response to a 1991 DOE investigation into accidental damage to a test item. The DOE identified a number of contributing issues with a lack of “formalized processes” as the most prevalent.

Sandia began by identifying existing procedures, identifying qualified personnel in the test and evaluation department to develop needed processes, and recruiting experienced test process development personnel. Test processes were evaluated and formalized documents were developed. SNL developed their test process documents such that their operations would be in compliance with tenets set forth in “DOE Conduct of Operations, Order 5480.19.” A key to the success of this effort was staff personnel development. Training based on Stephen Covey’s principles and on social styles was utilized to establish a common base for communication and interpersonal skills.

This undertaking in formal process documentation in test and evaluation produced effective results. In 1994, SNL had zero incidents or occurrences. Customer feedback metrics ranged from good to outstanding. Employee benefits were numerous, including an improved “job ownership” attitude stemming partly from a clearer understanding of job requirements and responsibilities, as well as improved interpersonal skills (communication, teamwork, mutual respect). In addition, the department experienced improved test cost estimating, cost savings, and the resultant contribution to future test cost planning.

## DETERMINE/DEFINE NEED FOR SYSTEM

### Systems Engineering

In 1993, Sandia initiated a Systems Engineering (SE) upgrade effort to improve the skills of the systems engineers and to incorporate new ideas and advances from recent developments in the SE field. The SE process is a comprehensive, disciplined, problem-solving process used to transform customer needs into a life-cycle, balanced, integrated system solution. It provides a framework from which requirements analysis, functional analysis, functional decomposition and allocation, synthesis, verification and valida-

tion, risk analysis, and trade studies can be conducted. It also controls the engineering effort, including project planning and project management activities. The SE effort is tailored for each customer and project to provide the best process for the requirements and problems being worked.

Sandia’s SE process is effected using a four-team approach including Process (develop and document “typical” SE process), Education (provide SE training and information to staff personnel), Tools (create an effective System Engineering environment), and Industry/University (team with industry/universities to improve SE skills).

Sandia expects to benefit by meeting customer requirements on time and within budget by creating fewer false starts from working the wrong problem, fewer “throwing-over-the-wall” activities by considering life cycle needs earlier, and enhanced traceability of what was done and why.

## QUALITY ASSURANCE

### President’s Quality Award

Sandia had no method to identify, recognize, and reward customer focused quality improvement processes at the team level. At the request of Sandia’s President, a team of Sandians began translating Malcolm Baldrige award principles into an internal set of criteria to encourage best practices within the laboratories and recognize those that have been successful in applying TQM principles. This criteria would directly apply to individual projects.

The improvements included securing top management commitment, a means to identify best practices, a focus on customer requirements, and an understanding of the TQM principles by laboratory personnel. The process was implemented in three phases.

- **Phase I** -- Process Development. Sandia’s President, Al Narath, asked that a process be designed to deploy TQM. Through this approach, SNL established a permanent Process Management Team. The team elected to adopt a Malcolm Baldrige-like methodology. This methodology forms the foundation for the President’s Quality Award.
- **Phase II** -- Process Implementation. Information regarding the application requirements were distributed to employees and the examiners received training in the review process. Awards are presented based upon scores in the categories of Gold, Silver, Turquoise, and Special Recognition.
- **Phase III** -- Process Improvement. “Lessons learned” data was gathered from applicants and examiners. SNL developed a feedback template for examiners and collected process feedback electronically. Plans for 1995 include tracking financial benefits from improvements resulting from team efforts.



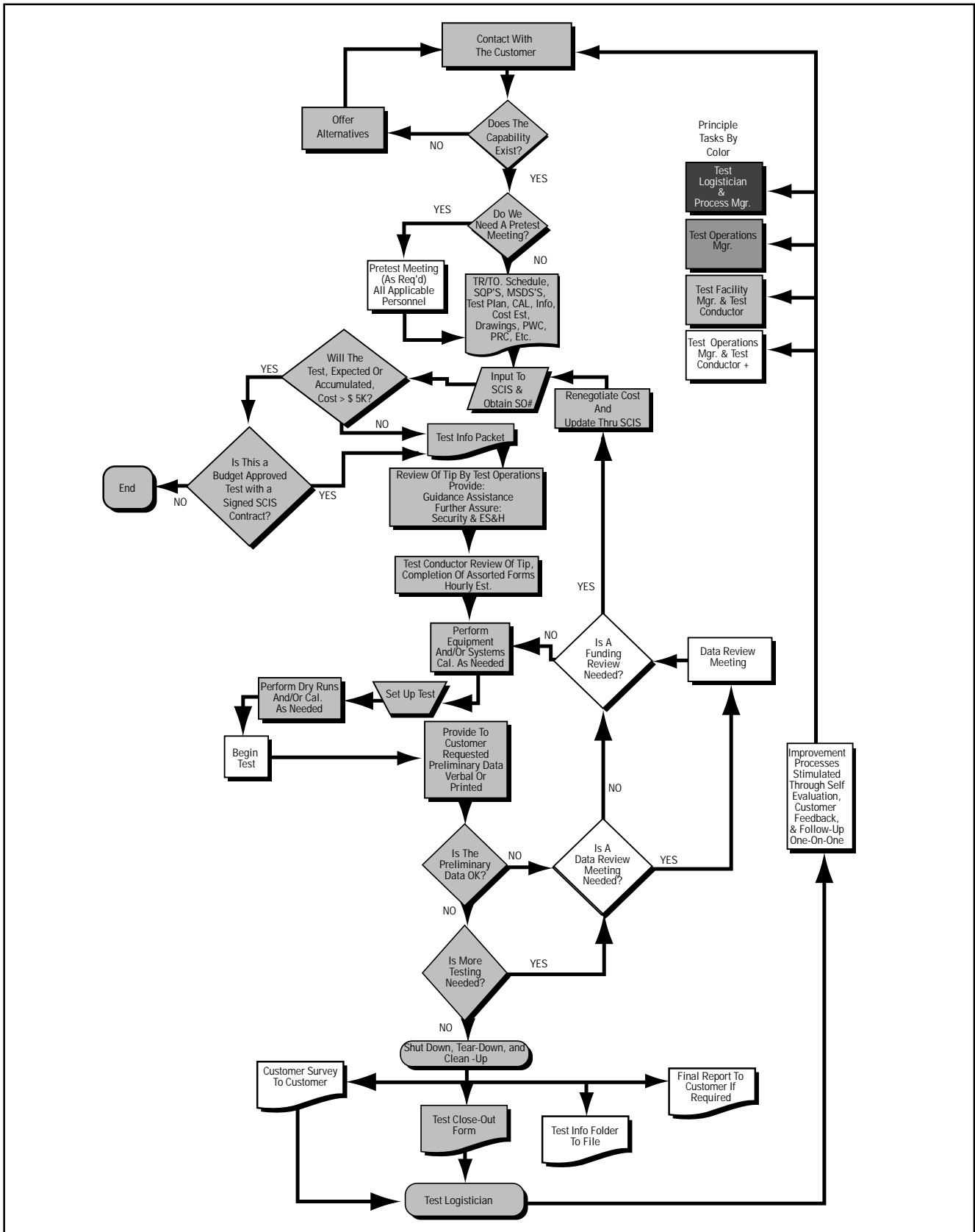

**FIGURE 3-17. PROCESS FLOW DIAGRAM**

---

The efforts over the past two years to deploy the quality message at SNL have been successful. The number of applicants for the President's Quality Award have increased as well as the number of examiners involved in the process.

## High Voltage Pulse Generator and Calibration Equipment

SNL's PSL redesigned and rebuilt the High-Voltage Pulse Generator (HVPG) for state-of-the-art operation using a computer-controlled system with user-friendly software in April 1989. This HVPG, originally installed in 1966, is primarily used for calibrating precision high-voltage dividers.

The HVPG calibrates precision high-voltage pulse dividers by comparing the magnitude of their output pulses with those of dividers whose calibration is traceable to NIST. With calibration processes to calibrate both resistive and capacitive voltage dividers, and the capability of providing pulse voltages to 350 kV with pulse time intervals from five microseconds to 20 microseconds, typical calibration uncertainties are 0.55%. High voltage pulses are produced by charging a pulse-forming network which, in return, discharges through the primary of a voltage step-up transformer using a thyatron switch.

The digitized calibration system includes sample mounting, safety checks, pulse measurement recording, data analysis, uncertainty calculations, and certificate generation. The actual time to run 13 voltage calibrations has been reduced from two hours to 40 minutes. During this period, the operator is free to perform other tasks, within hearing distance, through the use of a computer controlled voice synthesizer audio interface.

## Transitioning Existing Weapon Designs into Manufacture

The withdrawal of commercial suppliers resulted in the need for Sandia to develop their own capability for manufacturing War Reserve active ceramic components. Although the design and development activities had been performed at SNL, production experience was minimal. To meet the customers' needs, a TQM approach was taken to develop a production team.

The overall project planning focused on goals and establishing roles and responsibilities for each team member. The formation of a high performance team required dedication and buy-in of all those involved. Managers whose employees were part of the team were asked to sign contracts allowing for full participation of their employees. A key factor in the development of this team was having custom-

ers, in particular the DOE, as team members. Significant time was saved by having these customers on board and available for clarification of requirements when necessary.

The development of this team was a dynamic process. New members were added when the need for other personnel was identified by the core group. Team building exercises and a class on social styles were used to build the group's strengths.

Weekly reviews of the project plan were held. Integral to this review was the tracking of critical path tasks that had an impact on the project schedule, and each task owner identified and defined his tasks. Several quality tools such as Product/Quality Management Information style process flow charts, SPC, and root cause analysis were used throughout the project and led to improvements in the team's performance.

The results were impressive. Although it was determined that the ceramic components were not needed for immediate DOE production, the project was completed ahead of schedule and the parts were eventually used for research and development work. A DOE QAS-2.0 audit was conducted, and the production processes were found to be equal to or better than those of other audited suppliers. The team also received the highest scoring in the Sandia's President's Quality Award which is patterned after the Malcolm Baldrige National Quality Award.

## Qualification of Weapon Processes and Product

Traditional weapon process and product qualification in the U.S. Nuclear Weapons Complex involved assessment qualification by Qualification Evaluation Teams. Design and production agencies had separate responsibilities and used multiple, often different, procedures. Qualification of weapon process and product had to be re-engineered to accommodate constrained budgets and downsizing of the production complex and weapons stockpile. However, the requirement of retaining competence to perform weapon development and production responsibilities while providing options for improvements to stockpile safety, security, and reliability still represented a critical need.

To ensure effective future determinations that product design and associated manufacturing and acceptance processes would be capable of providing a product that meets customer requirements, Sandia National Laboratories participated in the development of a Nuclear Weapons Complex-wide Engineering Procedure.

This procedure calls for qualification to be performed in a uniform, four-stage process by interagency PRTs concur-

rently with other product realization activities (Figure 3-18). The uniform process stages are requirements verification; qualification plan generation and verification; qualification plan implementation and verification; and requirements validation. PRTs use existing engineering release and change order systems as they relate to the qualification process.

The engineering procedure applies to the development, design, fabrication, and acceptance of weapon and weapon-related materials and acceptance equipment. Also covered are weapon-related software, stockpile evaluation activities, dismantlement activities, and nuclear weapon demonstration programs. The concurrent qualification process helps guarantee that a project has met the goals and objectives of specific activities such as production readiness and environmental compliance.

The procedures required by this effort should better enable Sandia to satisfy customer requirements, promote teamwork, use metrics for continuous improvement, develop and implement life cycle project plans, and reduce life cycle cost.

### Sandia Volt Map Program

Sandia has used a Volt Map program for more than 20 years to certify Contractor Standards Lab cell banks. Specially selected transport standards are used for the maps.

The Sandia program was originally designed around the NIST program where a parent lab cell bank is shipped to the customer. Several years ago it became apparent that transporting the cell banks containing hazardous materials such as mercury, mercurous sulfate, and cadmium sulfate would become more difficult. Sandia investigated the possibility of using the 1.018 volt taps of Zener solid state voltage standards as the transport stan-

dards for the Volt Map. About the same time, Sandia implemented the Josephson Array Voltage Standard (Jo Volt) into their operation which made it simpler to accurately characterize the Zener standards that were being considered for transportation standards. The new Zener transportation plan was reviewed with John Fluke Inc. because of the company's extensive experience conducting a Volt Map program for Zeners at the 10V level. Based on the company's experience with shipping Federal Express - Overnight, Sandia chose Federal Express to eliminate one of the variables in the transportation process.

Sandia evaluated several different brands of Zeners. The Zeners underwent tests for short and long term stability, noise on the output terminals (which can make it difficult to calibrate with the Jo Volt), their sensitivity to changes in environments (i.e., temperature, humidity, and also pressure, since Sandia is at 5400 feet altitude), and how they could be shipped. The Zeners with the greatest potential were checked at Sandia using the Jo Volt standard, then shipped to NIST in Gaithersburg, MD, where they were checked with the Jo Volt standard and then returned to Sandia. Once again, they were checked and the process closed. The typical shift between Sandia and NIST was less than 0.2 ppm.

The initial evaluations consisted of measuring the 1.018 volt taps of three 732A Zeners, once each on five consecutive days with the Jo Volt for opening runs. If the results were within the expected system uncertainties, each Zener was packed with its external battery pack for shipment. Each Zener and battery pack weighed approximately 100 pounds. The external battery packs were necessary to supplement the internal batteries to allow the Zeners to stay powered for at least 48 hours. This was done to avoid a potential loss of power which had an unpredictable effect on the Zeners

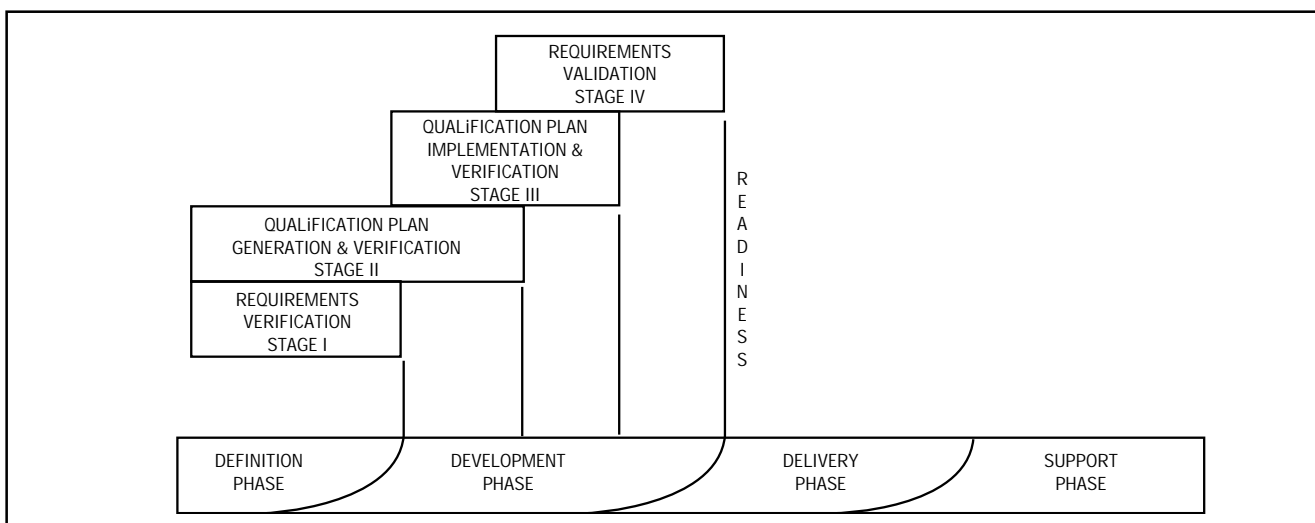

**FIGURE 3-18. CONCURRENT QUALIFICATION**

---

output voltage. Low thermal switches were also shipped to the customer for interconnecting the Zeners to their cell bank. To simplify the transportation of standards, a change was made to Fluke 732B Zeners. The Fluke 732B Zeners weigh 12 pounds, ship as well as the As, and their internal batteries alone are sufficient to power the Zener for more than 48 hours.

The customer runs a 3 by X (where "X" is the number of cells in the customer bank) test pattern every day for at least five days on each of the banks to be certified. The data is called into Sandia daily. Sandia checks each day's results using the opening run data. When five satisfactory runs have been completed on five separate days, the Zeners are returned to Sandia for five days of closing runs.

The average of the opening and closing runs data on the Sandia Zeners is used to help calculate the customer cell values used to certify the banks. The uncertainty assigned to the customer cells is an uncertainty for an interval, typically one year, that includes an allowance for the drift of the cell bank, from the last certification, and for the uncertainty of the transfer, which is determined from the differences in the opening and closing runs.

Sandia also calibrates customer Zeners that are sent in under battery power, typically the Zeners 1.018 and 10V taps voltage. Customer Zeners are calibrated using a Zener calibration system which was built for Sandia by NIST. The Sandia Zener calibration system is identical to the NIST

Zener calibration system. The as-measured uncertainty for these Zeners is increased for drift over the assigned calibration interval and for the effect of transport upon the Zeners. Because customer Zener transport characteristics are never well known (i.e., temperature, humidity, and pressure effects), the increase in uncertainty for transport can be substantial. The smallest uncertainty assigned to a customer Zener given a one year certification interval is three ppm. Since Sandia is already shipping well-characterized transfer Zeners to their customers, they also calibrate the 10V as well as the 1.018V taps on their Zeners so the customers can use them to calibrate their Zeners and cell banks. The customer Zener uncertainties will be significantly reduced because the customers' Zeners never leave the facility. Sandia expects to offer this new service in 1996.

Sandia is developing a portable, user friendly Jo Volt calibration system for Sandia and NASA. They are being assisted in this effort by NIST, Boulder, the developer of the 1V and 10V Josephson array chips. The Jo Volt standard is an intrinsic standard that converts frequency to voltage. The customer need only supply a 10 MHz frequency source that is known to an accuracy of 1 ppb, and a dewar of liquid helium to have a standard that would be accurate to better than 0.1 ppm over a voltage range of 0.5V to 11V. This will improve the as-measured uncertainty by a least a factor of ten. Sandia will offer these services to their customers in three to five years.

# APPENDIX A

## **TABLE OF ACRONYMS**

---

---

Acronym	Definition
A-PRIMED	Agile Product Realization of Innovative ElectroMechanical Devices
AANC	Aging Aircraft Non-destructive Inspection Validation Center
ACaPS	Agile Cable Acquisition and Production System
AIMS	Administrative Information Management System
AMTnet	Advanced Manufacturing Technology Network
CALSON	Computer-Aided Acquisition and Logistics Support Operational Network
CMOS	Complementary Metal-Oxide Semiconductor
CPM	Contract Project Manager
CRADA	Cooperative Research and Development Agreement
DOD	Department of Defense
DOE	Department of Energy
ES&H	Environment, Safety and Health
FACT	Facility for Acceptance Calibration and Testing
FAST	Facilities Accelerated Systems Team
FASTCAST	Fast Casting Process
HCSS	High Consequence System Surety
HVPG	High-Voltage Pulse Generator
ICE	Interactive Collaborative Environment
ICFAX	Integrated Circuit Failure Analysis Expert System
IDEA	Integrated Development Environment and Assistant
INTEC	In-hours Technical Education Courses
IVR	Interactive Voice Response
JIT	Just-In-Time
LVSPC	Low Volume Statistical Process Control
MLD	Manufacturing Liaison Department
NDE	Non-destructive Evaluation
NIST	National Institute of Standards and Technology
PCM	Process Characterization Methodology
PRT	Product Realization Team
PSL	Primary Standards Laboratory
QFD	Quality Function Deployment

# APPENDIX A

## ***TABLE OF ACRONYMS (Continued)***

---

---

Acronym	Definition
SCIS	Service Center Information System
SE	System Engineering
SHIELD	Self-stressing High-frequency Reliability Devices
SNL	Sandia National Laboratories
SPI	Software Process Improvement
SVIS	Sandia Voice Information System
SWORD	Sandia Wafer-level sOftware for Reliable Devices
TEAM	Technologies Enabling Agile Manufacturing
TIE-In	Technical Information-for Industry
TLC	Total Life Concept
VANA	Vector Automatic Network Analyzer

# APPENDIX B

## ***BMP SURVEY TEAM***

---

---

<b>Team Member</b>	<b>Agency</b>	<b>Function</b>
<b>Larry Robertson</b> (812) 854-5336	<b>Crane Division</b> <b>Naval Surface Warfare Center</b> Crane, IN	<b>Team Chairman</b>
<b>Amy Scanlan</b> 1-800-789-4BMP	<b>BMP Center of Excellence</b> College Park, MD	<b>Technical Writer</b>
<b>Adrienne Gould</b> 1-800-789-4BMP	<b>BMP Center of Excellence</b> College Park, MD	<b>Technical Writer</b>

### **DESIGN/TEST TEAM #1**

<b>Rick James</b> (317) 226-5619	<b>Electronics Manufacturing</b> <b>Productivity Facility</b> Indianapolis, IN	<b>Team Leader</b>
<b>Tom Hood</b> (814) 269-2803	<b>National Defense Center</b> <b>for Environmental Excellence</b> Johnstown, PA	
<b>Robert Montano</b> (909) 273-5339	<b>Naval Warfare Assessment Center</b> Corona, CA	
<b>*Jack Tamargo</b> (707) 642-4267	<b>BMP Representative</b> Vallejo, CA	
<b>Rick King</b> (812) 854-5131	<b>Crane Division</b> <b>Naval Surface Warfare Center</b> Crane, IN	

### **DESIGN/TEST TEAM #2**

<b>Tim LaCoss</b> (518) 266-4566	<b>U.S. Army Watervliet Arsenal</b> Watervliet, NY	<b>Team Leader</b>
<b>Gary Combs</b> (206) 396-1807	<b>Naval Undersea Warfare</b> <b>Center - Keyport Division</b> Keyport, WA	
<b>Marshall Bramble</b> (502) 364-5272	<b>Crane Division, Louisville Site</b> <b>Naval Surface Warfare Center</b> Louisville, KY	
<b>John Miles</b> (812) 854-5335	<b>Crane Division</b> <b>Naval Surface Warfare Center</b> Crane, IN	

# ***BMP SURVEY TEAM (Continued)***

---

<b>Team Member</b>	<b>Agency</b>	<b>Function</b>
--------------------	---------------	-----------------

**DESIGN/TEST TEAM # 3**

<b>Chuck McLean</b> (301) 975-3511	<b>National Institute of Standards and Technology</b> Gaithersburg, MD	<b>Team Leader</b>
<b>Steve Ratz</b> (317) 353-7151	<b>Naval Air Warfare Center Aircraft Division - Indianapolis</b> Indianapolis, IN	
<b>Al Mense</b> (703) 271-9055	<b>BMP Representative</b> Washington, DC	
<b>Jeff Parks</b> (810) 574-5558	<b>U.S. Army Tank Automotive Command</b> Warren, MI	

**PRODUCTION/FACILITIES TEAM**

<b>Don Hill</b> (317) 353-3781	<b>Naval Air Warfare Center Aircraft Division - Indianapolis</b> Indianapolis, IN	
<b>John Greaves</b> (317) 226-5665	<b>Electronics Manufacturing Productivity Facility</b> Indianapolis, IN	<b>Team Leader</b>
<b>Jack Tamargo</b> (707) 642-4267	<b>BMP Representative</b> Vallejo, CA	
<b>Cynthia Krist</b> (309) 782-7861	<b>U.S. Army Rock Island Arsenal</b> Rock Island, IL	
<b>*Rick King</b> (812) 854-5131	<b>Crane Division</b> <b>Naval Surface Warfare Center</b> Crane, IN	

**\*Denotes participation by this team member on more than one team**



## ***BMP SURVEY TEAM (Continued)***

---

---

<b>Team Member</b>	<b>Agency</b>	<b>Function</b>
<b>LOGISTICS/MANAGEMENT TEAM</b>		
<b>Rick Purcell</b> 1-800-789-4BMP	<b>BMP Center of Excellence</b> College Park, MD	<b>Team Leader</b>
<b>John Olewnik</b> (215) 697-9527\6	<b>Naval Industrial Resources Support Activity</b> Philadelphia, PA	
<b>Carlos Myers</b> (317) 353-4273	<b>Naval Air Warfare Center Aircraft Division - Indianapolis</b> Indianapolis, IN	
<b>Tammie Vogler</b> 1-800-789-4BMP	<b>BMP Center of Excellence</b> College Park, MD	



# APPENDIX C

## PROGRAM MANAGER'S WORKSTATION

---

The Program Manager's Workstation (PMWS) is a series of expert systems that provides the user with knowledge, insight, and experience on how to manage a program, address technical risk management, and find solutions that industry leaders are using to reduce technical risk and improve quality and productivity. This system is divided into four main components; KNOW-HOW, Technical Risk Identification and Mitigation System (TRIMS), BMP Database, and Best Manufacturing Practices Network (BMPNET).

- **KNOW-HOW** is an intelligent, automated method that turns "Handbooks" into expert systems, or digitized text. It provides rapid access to information in existing handbooks including Acquisition Streamlining, Non-Development Items, Value Engineering, NAVSO P-6071 (Best Practices Manual), MIL-STD-2167/2768, SecNav 5000.2A and the DoD 5000 series documents.

- **TRIMS** is based on DoD 4245.7-M (the transition templates), NAVSO P-6071 and DoD 5000 event oriented acquisition. It identifies and ranks the high risk areas in a program. TRIMS conducts a full range of risk assessments throughout the acquisition process so corrective action can be initiated before risks develop into problems. It also tracks key project documentation from concept through production including goals, responsible personnel, and next action dates for future activities in the development and acquisition process.

- The **BMP Database** draws information from industry, government, and the academic communities to include documented and proven best practices in design, test, production, facilities, management, and logistics.

Each practice in the database has been observed and verified by a team of experienced government engineers. All information gathered from BMP surveys is included in the BMP Database, including this survey report.

- **BMPNET** provides communication between all PMWS users. Features include downloading of all programs, E-mail, file transfer, help "lines", Special Interest Groups (SIGs), electronic conference rooms and much more. Through BMPNET, IBM or compatible PC's and Macintosh computers can run all PMWS programs.

- To access **BMPNET** efficiently, users need a special modem program. This program can be obtained by calling the BMPNET using a VT-100/200 terminal emulator set to 8,N,1. Dial (703) 538-7697 for 2400 baud modems and (703) 538-7267 for 9600 baud and

14.4 kb. When asked for a user profile, type: DOWNNPC or DOWNMAC <return> as appropriate. This will automatically start the Download of our special modem program. You can then call back using this program and access all BMPNET functions. The General User account is:

USER PROFILE: BMPNET

USER I.D.: BMP

Password: BMPNET

If you desire your own personal account (so that you may receive E-Mail), just E-Mail a request to either Ernie Renner (BMP Director) or Brian Willoughby (CSC Program Manager). If you encounter problems please call (703) 538-7799.

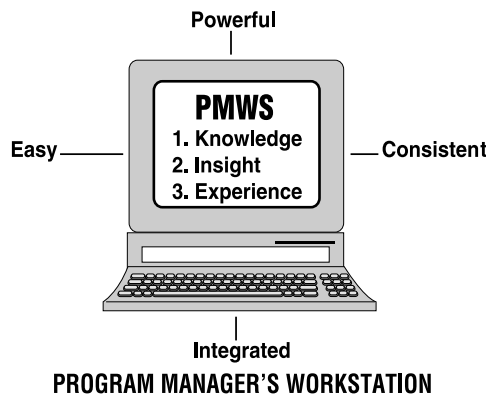



# APPENDIX D

## NAVY CENTERS OF EXCELLENCE

---

---

### **Automated Manufacturing Research Facility**

(301) 975-3414

The Automated Manufacturing Research Facility (AMRF) – a National Center of Excellence – is a research test bed at the National Institute of Standards and Technology located in Gaithersburg, Maryland. The AMRF produces technical results and transfers them to the Navy and industry to solve problems of automated manufacturing. The AMRF supports the technical work required for developing industry standards for automated manufacturing. It is a common ground where industry, academia, and government work together to address pressing national needs for increased quality, greater flexibility, reduced costs, and shorter manufacturing cycle times. These needs drive the adoption of new computer-integrated manufacturing technology in both civilian and defense sectors. The AMRF is meeting the challenge of integrating these technologies into practical, working manufacturing systems.

### **Electronics Manufacturing Productivity Facility**

(317) 226-5607

Located in Indianapolis, Indiana, the Electronics Manufacturing Productivity Facility (EMPF) is a National Center of Excellence established to advance state-of-the-art electronics and to increase productivity in electronics manufacturing. The EMPF works with industry, academia, and government to identify, develop, transfer, and implement innovative electronics manufacturing technologies, processes, and practices. The EMPF conducts applied research, development, and proof-of-concept electronics manufacturing and design technologies, processes, and practices. It also seeks to improve education and training curricula, instruction, and necessary delivery methods. In addition, the EMPF is striving to identify, implement, and promote new electronics manufacturing technologies, processes, materials, and practices that will eliminate or reduce damage to the environment.

### **National Center for Excellence in Metalworking Technology**

(814) 269-2420

The National Center for Excellence in Metalworking Technology (NCEMT) is located in Johnstown, Pennsylvania and is operated by Concurrent Technologies Corporation (CTC), a subsidiary of the University of Pittsburgh Trust. In support of the NCEMT mission, CTC's primary focus includes working with government and industry to develop improved manufacturing technologies including advanced methods, materials, and processes, and transfer-

ring those technologies into industrial applications. CTC maintains capabilities in discrete part design, computerized process analysis and modeling, environmentally compliant manufacturing processes, and the application of advanced information science technologies to product and process integration.

### **Center of Excellence for Composites Manufacturing Technology**

(414) 947-8900

The Center of Excellence for Composites Manufacturing Technology (CECMT), a national resource, is located in Kenosha, Wisconsin. Established as a cooperative effort between government and industry to develop and disseminate this technology, CECMT ensures that robust processes and products using new composites are available to manufacturers. CECMT is operated by the Great Lakes Composites Consortium. It represents a collaborative approach to provide effective advanced composites technology that can be introduced into industrial processes in a timely manner. Fostering manufacturing capabilities for composites manufacturing will enable the U.S. to achieve worldwide prominence in this critical technology.

### **Navy Joining Center**

(614) 486-9423

The Navy Joining Center (NJC) is a Center of Excellence established to provide a national resource for the development of materials joining expertise, deployment of emerging manufacturing technologies, and dissemination of information to Navy contractors, subcontractors, Navy activities, and U.S. industry.

The NJC is located in Columbus, Ohio, and is operated by Edison Welding Institute (EWI), the nation's largest industrial consortium dedicated to materials joining. The NJC combines these resources with an assortment of facilities and demonstrated capabilities from a team of industrial and academic partners. NJC technical activities are divided into three categories - Technology Development, Technology Deployment, and Technology Transfer. Technology Development maintains a goal to complete development quickly to initiate deployment activities in a timely manner. Technology Deployment includes projects for rapid deployment teaming and commercialization of specific technologies. The Technology Transfer department works to disseminate pertinent information on past and current joining technologies both at and above the shop floor.



# APPENDIX E

## *NEW BEST MANUFACTURING PRACTICES PROGRAM TEMPLATES*

---

---

Since 1985, the BMP Program has applied the templates philosophy with well-documented benefits. Aside from the value of the templates, the templates methodology has proven successful in presenting and organizing technical information. Therefore, the BMP program is continuing this existing “knowledge” base by developing 17 new templates that complement the existing DoD 4245.7-M or Transition from Design to Production templates.

The development of these new templates was based in part on Defense Science Board studies that have identified new technologies and processes that have proven successful in the last few years. Increased benefits could be realized if these activities were made subsets of the existing, compatible templates.

Also, the BMP Survey teams have become experienced in classifying Best Practices and in technology transfer.

The Survey team members, experts in each of their individual fields, determined that data collected, while related to one or more template areas, was not entirely applicable. Therefore, if additional categories were available for Best Practices “mapping,” technology transfer would be enhanced.

Finally, users of the Technical Risk Identification and Mitigation System (TRIMS) found that the program performed extremely well in tracking most key program documentation. However, additional categories – or templates – would allow the system to track all key documentation.

Based on the above identified areas, a core group of activities was identified and added to the “templates baseline.” In addition, TRIMS was modified to allow individual users to add an unlimited number of user-specific categories, templates, and knowledge-based questions.





# APPENDIX F

## ***COMPLETED SURVEYS***

---

---

BMP surveys have been conducted at the companies listed below. Copies of older survey reports may be obtained through DTIC or by accessing the BMPNET. Requests for copies of recent survey reports or inquiries regarding the BMPNET may be directed to:

Best Manufacturing Practices Program  
4321 Hartwick Rd.  
Suite 308  
College Park, MD 20740  
Attn: Mr. Ernie Renner, Director  
Telephone: 1-800-789-4267  
FAX: (301) 403-8180

### **COMPANIES SURVEYED**

Litton  
Guidance & Control Systems Division  
Woodland Hills, CA  
October 1985 and February 1991

Texas Instruments  
Defense Systems & Electronics Group  
Lewisville, TX  
May 1986 and November 1991

Harris Corporation  
Government Support Systems Division  
Syosset, NY  
September 1986

Control Data Corporation  
Government Systems Division  
(Computing Devices International)  
Minneapolis, MN  
December 1986 and October 1992

ITT  
Avionics Division  
Clifton, NJ  
September 1987

UNISYS  
Computer Systems Division  
(Paramax)  
St. Paul, MN  
November 1987

Honeywell, Incorporated  
Undersea Systems Division  
(Alliant Tech Systems, Inc.)  
Hopkins, MN  
January 1986

General Dynamics  
Pomona Division  
Pomona, CA  
August 1986

IBM Corporation  
Federal Systems Division  
Owego, NY  
October 1986

Hughes Aircraft Company  
Radar Systems Group  
Los Angeles, CA  
January 1987

Rockwell International Corporation  
Collins Defense Communications  
Cedar Rapids, IA  
October 1987

Motorola  
Government Electronics Group  
Scottsdale, AZ  
March 1988

---

General Dynamics  
Fort Worth Division  
Fort Worth, TX  
May 1988

Hughes Aircraft Company  
Missile Systems Group  
Tucson, AZ  
August 1988

Litton  
Data Systems Division  
Van Nuys, CA  
October 1988

McDonnell-Douglas Corporation  
McDonnell Aircraft Company  
St. Louis, MO  
January 1989

Litton  
Applied Technology Division  
San Jose, CA  
April 1989

Standard Industries  
LaMirada, CA  
June 1989

Teledyne Industries Incorporated  
Electronics Division  
Newbury Park, CA  
July 1989

Lockheed Corporation  
Missile Systems Division  
Sunnyvale, CA  
August 1989

General Electric  
Naval & Drive Turbine Systems  
Fitchburg, MA  
October 1989

TRICOR Systems, Incorporated  
Elgin, IL  
November 1989

TRW  
Military Electronics and Avionics Division  
San Diego, CA  
March 1990

Texas Instruments  
Defense Systems & Electronics Group  
Dallas, TX  
June 1988

Bell Helicopter  
Textron, Inc.  
Fort Worth, TX  
October 1988

GTE  
C<sup>3</sup> Systems Sector  
Needham Heights, MA  
November 1988

Northrop Corporation  
Aircraft Division  
Hawthorne, CA  
March 1989

Litton  
Amecom Division  
College Park, MD  
June 1989

Engineered Circuit Research, Incorporated  
Milpitas, CA  
July 1989

Lockheed Aeronautical Systems Company  
Marietta, GA  
August 1989

Westinghouse  
Electronic Systems Group  
Baltimore, MD  
September 1989

Rockwell International Corporation  
Autonetics Electronics Systems  
Anaheim, CA  
November 1989

Hughes Aircraft Company  
Ground Systems Group  
Fullerton, CA  
January 1990

MechTronics of Arizona, Inc.  
Phoenix, AZ  
April 1990

---

Boeing Aerospace & Electronics  
Corinth, TX  
May 1990

Textron Lycoming  
Stratford, CT  
November 1990

Naval Avionics Center  
Indianapolis, IN  
June 1991

Kurt Manufacturing Co.  
Minneapolis, MN  
July 1991

Raytheon Missile Systems Division  
Andover, MA  
August 1991

Tandem Computers  
Cupertino, CA  
January 1992

Conax Florida Corporation  
St. Petersburg, FL  
May 1992

Hewlett-Packard  
Palo Alto Fabrication Center  
Palo Alto, CA  
June 1992

Digital Equipment Company  
Enclosures Business  
Westfield, MA and  
Maynard, MA  
August 1992

NASA Marshall Space Flight Center  
Huntsville, AL  
January 1993

Department of Energy-  
Oak Ridge Facilities  
Operated by Martin Marietta Energy Systems, Inc.  
Oak Ridge, TN  
March 1993

Technology Matrix Consortium  
Traverse City, MI  
August 1990

Norden Systems, Inc.  
Norwalk, CT  
May 1991

United Electric Controls  
Watertown, MA  
June 1991

MagneTek Defense Systems  
Anaheim, CA  
August 1991

AT&T Federal Systems Advanced  
Technologies and AT&T Bell Laboratories  
Greensboro, NC and Whippany, NJ  
September 1991

Charleston Naval Shipyard  
Charleston, SC  
April 1992

Texas Instruments  
Semiconductor Group  
Military Products  
Midland, TX  
June 1992

Watervliet U.S. Army Arsenal  
Watervliet, NY  
July 1992

Naval Aviation Depot  
Naval Air Station  
Pensacola, FL  
November 1992

Naval Aviation Depot  
Naval Air Station  
Jacksonville, FL  
March 1993

McDonnell Douglas Aerospace  
Huntington Beach, CA  
April 1993

---

Crane Division  
Naval Surface Warfare Center  
Crane, IN and Louisville, KY  
May 1993

Philadelphia Naval Shipyard  
Philadelphia, PA  
June 1993

R. J. Reynolds Tobacco Company  
Winston-Salem, NC  
July 1993

Crystal Gateway Marriott Hotel  
Arlington, VA  
August 1993

Hamilton Standard  
Electronic Manufacturing Facility  
Farmington, CT  
October 1993

Alpha Industries, Inc  
Methuen, MA  
November 1993

Harris Semiconductor  
Melbourne, FL  
January 1994

United Defense, L.P.  
Ground Systems Division  
San Jose, CA  
March 1994

Naval Undersea Warfare Center  
Division Keyport  
Keyport, WA  
May 1994

Mason & Hanger  
Silas Mason Co., Inc.  
Middletown, IA  
July 1994

Kaiser Electronics  
San Jose, CA  
July 1994

Sandia National Laboratories  
Albuquerque, NM  
February 1995

---