

Fact Sheet

ENVIRONMENTAL SERVICES DIVISION

State of Michigan · Departments of Commerce and Natural Resources

TEN WAYS TO REDUCE MACHINE COOLANT COSTS

This fact sheet describes fluid handling, maintenance and disposal principles that will reduce machine coolant costs in metal cutting and grinding operations. Some of the principles are simple and cost nothing to implement. Others require capital investment.

Actually, saving money is not difficult. Coolant costs can be reduced by:

1. Extending coolant life as long as possible.
2. Disposing unusable coolant at the lowest cost.

The following ten principles describe how to extend coolant life and dispose unusable or unwanted coolant at the lowest cost. The recommendations are given for water miscible coolants but can be applied to other coolant types. Your company's profitability can be increased by practicing the principles that follow.

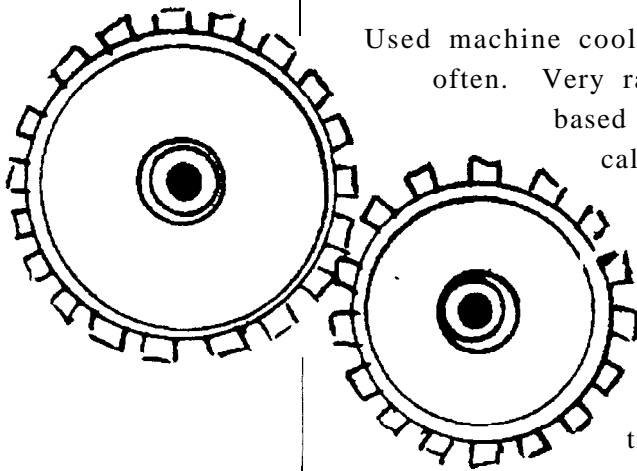

Used machine coolants do not need to be disposed often. Very rarely are coolants, either petroleum based or synthetic, structurally or chemically degraded by use. With only slight attention, primarily by making sure that coolant composition is correct and contaminants do not build up to the point of interfering with performance, most coolants can be used many times. Each time that coolant is reused, money is saved through decreased coolant purchasing and disposal costs. Extending coolant life pays dividends.

Of course, coolants can become unusable through neglect. Knowing low cost ways to dispose used coolant can save money too.

EDUCATION/OUTREACH
RECYCLING/ENERGY
SITE REFUSE & REDEVELOPMENT
SMALL BUSINESS CLEAN AIR
ASSISTANCE
WASTE REDUCTION SERVICES

PO BOX 30004
LANSING MICHIGAN 48909
(517) 335-1178 | 1-800-662-9278
FAX: (517) 335-4729

WASTE REDUCTION SERVICES

"A Partnership to Benefit Both Economic Development and the Environment"

① KEEP GOOD RECORDS

Companies often do not know the true costs of their machine coolants. They usually know the cost per gallon to buy new coolant and to have used coolant hauled away, but coolants can affect production costs in many other ways.

Companies are wise to track the following to make sure that coolants are “right” for their metalworking operations.

- a. **Tool Life** - The frequency of sharpening and replacing worn tools relates directly to the effectiveness of the machine coolant. Properly formulated and maintained coolant can double, and sometimes triple, tool life.
- b. **Surface Finish** - Closely related to tool life is the quality of finish being produced on work pieces. Poor finish is usually due to inadequate lubricity or corrosion resistance provided by the coolant being used. The “right” coolants will produce smooth finishes, free of stains.
- c. **Production Rate** - Good coolants make metalworking equipment “hum.” Production will be steady and predictable. Improperly formulated or “dirty” coolant will cause erratic, unpredictable production output.
- d. **Downtime** - Frequency of machine adjustment to hold dimensional tolerances, sharpening and replacing worn tools and draining and cleaning the coolant system will increase rapidly when the “right” coolant is **not** being used.

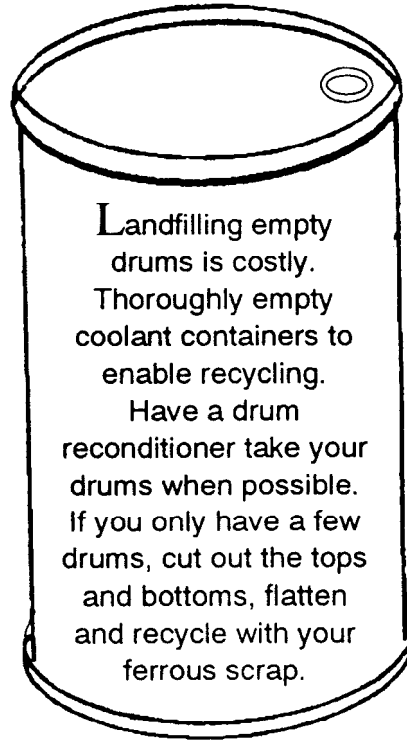

- e. **Disposal** - Volume of coolant disposal is directly related to the number of times that coolant is reused. Each time that coolant is reused, disposal costs are reduced. These cost savings should be taken into account when investment in coolant recycling equipment is being considered.

② STANDARDIZE COOLANTS

Using one coolant formulation for all types of metal and metalworking operations is seldom possible. However, using more coolant variations than is necessary is a mistake. As a general rule in most shops, no more than three coolant mixes should be used. Try to use different concentrations of the same coolant concentrate rather than totally different formulations when possible. The fewer variations used, the better.

Each new coolant mix carries a price tag over and above its cost per gallon. More labor and capital equipment is required to prepare, monitor, store and reclaim each additional mix. Coolant recycling systems are most efficient when few coolant variations are processed.

A good way to standardize coolants is to form a Coolant Control Committee having responsibility for approving new coolant formulations. The committee should consist of production, manufacturing engineering, environmental control, medical, quality control and purchasing people. The group should be instructed by management to authorize new formulations only after it has been demonstrated that no currently used coolant mix is capable of doing new production jobs. Do not allow individual machine operators, no matter how experienced, to choose coolants. Machine operators sometimes want to use special coolant mixes, without considering overall costs to the company.

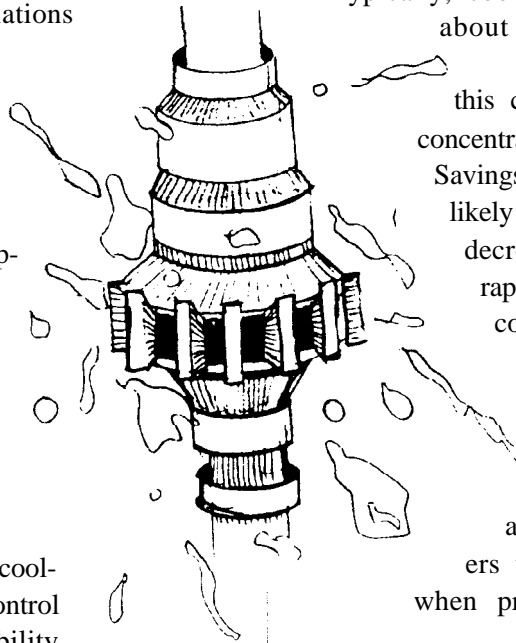

③ BUY QUALITY COOLANTS FROM QUALITY SUPPLIERS

Do not buy low cost, low quality coolants. Almost always, higher priced coolants are better, providing "tighter," more stable emulsions, longer lasting lubricity and better corrosion protection. They will outlast and outperform the "bargain specials" every time.

Typically, coolant purchase price is only about 1/2 percent of total metal-

this cost by buying low cost concentrate is not a good idea. Savings in concentrate cost will likely be far outweighed by decreased productivity, more rapid tool wear and increased coolant maintenance and

Buy coolants from only one or two suppliers.

Vendor loyalty is often advantageous. Loyal suppliers will respond more quickly when problems develop.

Most importantly, select suppliers that support their products. Supportive suppliers will have laboratory facilities that are equipped to measure the chemical and physical characteristics of used coolants. Supportive suppliers will also have technical staff capable of analyzing coolant problems and recommending cost-effective solutions. Your coolant supplier should help make sure that your metalworking operations are performing as efficiently as possible and at lowest overall cost.

4 BUY COMPATIBLE COOLANTS, LUBRICANTS AND HYDRAULIC FLUIDS

The most common contaminant in metalworking coolants is “tramp” oil. Tramp oil is formed when drops of lubricating oils, grease and hydraulic fluids fall from metalworking machinery into coolant. It is also caused by oily, corrosion protective coatings on workpieces. Keep in mind that lubricants, hydraulic fluids and corrosion protective coatings should not ordinarily emulsify or dissolve in water. This is necessary for their intended uses. But, because they do not emulsify readily, the droplets collect together as floating covers on coolant bath surfaces. This causes problems.

Although not always, it is sometimes possible to buy lubricants, greases and coolants that are chemically compatible. Suppliers can provide information on what materials work well together. Plan to buy the materials as an interacting system. Do not purchase each material individually without considering chemical compatibilities.

In some instances, fluids can be multi-functional. A few companies are using emulsion-type coolant concentrate as gear box and slide way oils. Others have successfully formulated inactive (i.e. having no chlorine, phosphorous or sulfur compound additives), non-emulsifiable oils for use as gear box and slide way lubrication, as a hydraulic fluid and as a metalcutting coolant. It must be recognized, however, that these successes are specific to the using company’s operations. Successful multiple use under other conditions cannot be guaranteed.

Non-emulsifiable cutting oils, especially those that do not contain active sulfur, will provide good in-process corrosion protection for most ferrous and non-ferrous metals. The same is true of water miscible cutting and grinding fluids, provided they are properly maintained. The materials must be free of tramp oils and metal fines and have a low bacterial level when applied to metals for good corrosion protection.

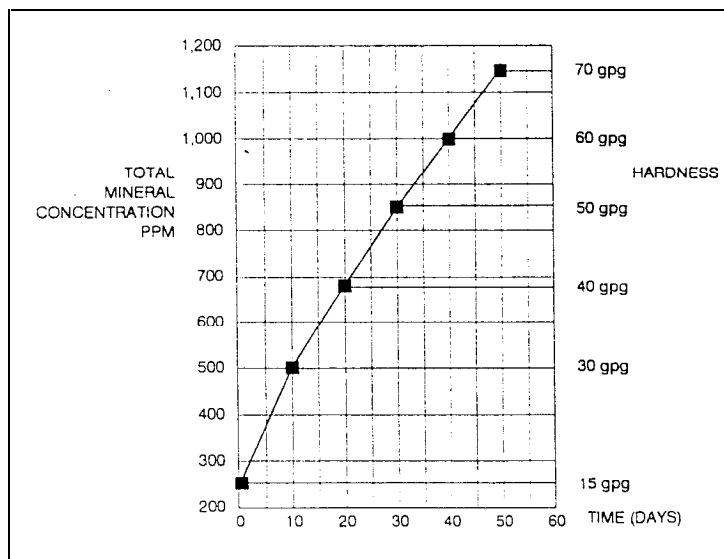

*Figure 1
Build-Up of Minerals When 250 ppm Water is Used
for Make-up of Evaporative Losses*

If coolants, lubricants, hydraulic fluids and corrosion protective coatings are not fully compatible, it is best that they be immiscible in each other. This means that they will readily separate after mixing. As a rule of thumb, buy coolants that do not readily emulsify lubricating and hydraulic oils and buy water resistant lubricating oils, water-proof greases and water displacing corrosion inhibitors. Coolant recycling is more effective and coolant quality can be maintained for longer periods when coolants readily separate from the other fluids.

⑤ USE "PURE" WATER

The minerals that are present in most surface and ground waters in Michigan are very detrimental to machine coolants. They react with, and use up, the emulsifiers in the coolant. They cause the build-up of residues on machine tools and workpieces and contribute to workpiece and tool corrosion. They also increase the rate at which bacteria and fungi grow in the coolant, which shortens coolant life. For trouble-free and long-life coolant mixes, use water that has low mineral content.

Water hardness is primarily due to the presence of calcium and magnesium salts in the water. Iron and aluminum salts also contribute. (Significant iron content will frequently give the appearance of rust on workpieces when the coolant dries.) One "U.S. grain per gallon" of hardness is the equivalent of 17.1 ppm of calcium carbonate in ionic strength. A rule of thumb is that for every one grain of hardness present in a plant's water supply, annual consumption of coolant concentrate will increase by one percent. For example, a plant having a water supply containing 8 grains of hardness could reduce its annual coolant costs 8 percent by using pure water instead. Water having 15 grains or more of hardness will frequently "split" poor quality emulsions and will often cause severe corrosion and residue problems, even with good quality emulsions.

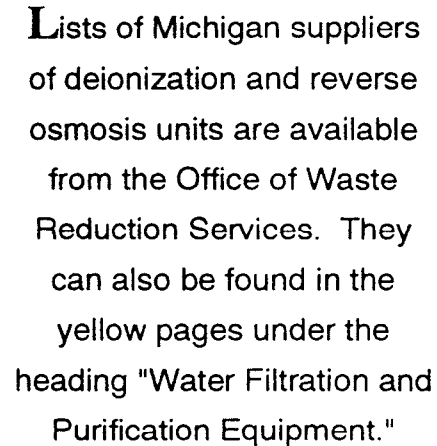

Lists of Michigan suppliers of deionization and reverse osmosis units are available from the Office of Waste Reduction Services. They can also be found in the yellow pages under the heading "Water Filtration and Purification Equipment."

Water hardness throughout the Great Lakes basin is high compared with most other parts of the country. Groundwater hardness in Michigan is typically about 10 grains (180 ppm). Water hardness in Lakes Michigan, Huron and Erie averages about 8 grains (135 ppm). Suppliers formulate coolants for average water hardness in each marketing area. But, hardness can vary significantly within a geographic area due to different geological structures in the ground. In order to mix coolants for optimum performance, it is essential that you know the hardness of your water supply.

Unfortunately, water having low mineral content can cause a problem. Water with extremely low mineral content can increase the tendency for some types of coolant to foam when freshly mixed. This can often be corrected by periodically adding defoamers until enough tramp oil and dirt accumulate in the coolant to suppress foaming tendencies. Another technique that can be used to control

foam is to use a mixture of hard water (e.g. 20 - 50 percent) and pure water (e.g. 80 - 50 percent) for preparing coolant mixes that will be used when starting up a new or cleaned metalworking system. All make-up coolant mixes, however, should be made with pure water only.

It is important to use only pure water when preparing make-up fluid to replace evaporative losses from coolant systems. Typically, from 5 to 10 percent of the coolant in a system is lost each day and 80 percent of the loss is water. By adding only pure water as make-up, the mineral content of such systems stays the same. Neither coolant performance degradation nor foaming problems are likely to occur. On the other hand, if well water or high hardness tap water is used for make-up, the mineral content of coolant systems will keep increasing, quickly making the coolant unusable. As shown in Figure 1, the mineral content of coolant systems can double within two weeks when "hard" water is used for make-up.

If available, and provided no water softeners or anti-corrosion chemicals have been added, boiler water condensate is a good source for mineral-free water. Rainwater is another good source. However, most industrial mineral-free water is obtained by deionization (DI) or reverse osmosis (RO).

Exchange type deionizer systems are recommended as a source for pure water for smaller metalworking shops where: water requirements are likely to be 300 gpd (gallons per day) or less and the hardness of the water supply does not exceed 10 grains. When water requirements exceed 300 gpd and the hardness of the water supply exceeds 10 grains, tank deionizers become uneconomical. In such instances, automatic, self-regenerating deionizers or a reverse osmosis system is suggested. RO systems do not produce as high water purity as deionizers but RO water

is usually sufficiently pure for coolant applications. Some metalworking shops that require high volume "pure" water use an RO system and an exchange tank deionizing system together. The RO system removes most impurities and the DI system "polishes" the water. As a result, large volumes of high purity water are produced at relatively low cost.

Water purification systems (deionizers and reverse osmosis systems) should normally be sized for coolant systems based on daily fluid make-up volume to minimize equipment cost. However, while this is satisfactory for most plants, facilities that have very large (over 5,000 gallons) coolant systems will need somewhat larger equipment or they will find that an adequate supply of pure water will not be available for preparing coolant mixes when rapid filling of new or cleaned systems is desired.

Water "softeners" are not recommended for preparing water for use in machine coolants. In the water softening process, calcium, magnesium, iron and aluminum ions are exchanged for (i.e. replaced by) sodium ions. Unfortunately, softeners do **not** remove the extremely corrosive chloride and sulfate ions from processed water. Total unwanted ionic content of softened water is the same as was present in the water before processing and is often sufficiently high to affect emulsion stability. Sticky residues caused by ionic minerals are no longer a problem with softened water but rust, corrosion and staining problems on machines, tools, fixtures and workpieces can actually be more severe than with untreated hard water.

⑥ MAINTAIN COOLANT CONCENTRATION AND PH

A major coolant supplier attributes 80 percent of customer "trouble" calls to poor control of coolant concentration and pH. It is essential that coolant maintenance be ongoing and performed by trained staff.

Good control is almost impossible if performed by individual machine operators in small batches. In small and medium size shops, one person should be responsible for preparing and maintaining all coolants. In large shops, one person should have the responsibility for each shift or department.

The important thing is that only individuals who are trained to monitor coolant performance and analyze what is happening be allowed to make concentration or pH adjustments. Also, they should not be allowed to add bactericides, emulsifiers or other materials to the coolant. If untrained individuals are allowed to change coolant composition, the philosophy often is, "If a little bit helps, a large amount will help a lot." Unfortunately, this is seldom true with coolants.

The preparation of emulsion type coolants should start by emulsifying coolant concentrate. It is recommended that the concentrate be emulsified first in pure water (always adding the concentrate to the water and mixing thoroughly) in a ratio of 25 percent concentrate/75 percent water. This "concentrated emulsion" can be added to tap water when coolant is to be used to refill a new or cleaned system. However, it should be mixed with pure water if the coolant is to be used for make-up.

Water alone should never be added to coolant systems to adjust concentration. It is vitally important that some small quantity of fresh coolant concentrate be pre-mixed with make-up water. This concentrate replaces concentrate that is carried from the coolant system on machined parts and chips.

Coolant mixing, whether for initial charging of machines or supplying make-up, is best accomplished by the use of automatic proportional mixers. Such units provide accurate concentration control, mix coolants properly and eliminate "human error," including accidental spilling. Often 10 to 15 percent of normal coolant usage can be saved with their use. Positive displacement, proportioning pumps are preferred to Venturi (syphon type) mixers, as positive displacement pumps are unaffected by variations of water pressure, flow rate, fluid viscosity or the depth of fluid in the drum or tote supplying the concentrate. All of these variables affect the accuracy of Venturi type proportioners.

Coolant concentration can be determined relatively easily on the plant floor with a refractometer. Most coolant suppliers sell the instrument as a service to their customers. The suppliers will also provide conversion factors to convert refractometer readings into percent concentration for their coolants.

With most machine coolants, pH should be held between 8.8 and 9.3. Bacterial growth increases exponentially when pH is below 8.3 and carbon steel can rust when pH is less than about 7.5. Dilute potassium hydroxide (KOH) and other alkalies, such as borax, can be used to raise pH. In all cases, follow the recommendations of your concentrate supplier. High pH is to be avoided, of course, as highly alkaline coolant will be harsh to your workers' skin.

Check coolant concentration and pH daily or more frequently if unusual machining performance is experienced.

7 PREVENT COOLANT CONTAMINATION

Organic contaminants in machine coolants provide food for bacteria and fungi that generate odors and lower pH. This, in turn, decreases coolant lubricity and increases corrosivity. The old axiom - the best defense is a strong offense - applies. The best way to prevent bacterial and fungal growth is to try every way possible to keep contaminants out of the coolant.

Tramp oils are the first concern. The most effective way to keep machine oils, greases and hydraulic fluids out of machine coolants is to maintain the metalworking machinery. Stop the leaks. Replace defective bushings, seals and gaskets. Also, install splash shields and catch basins. The coolant system should not be a catch basin for leaking lubricants.

Try to minimize the amount of corrosion protective oils that enter the coolant from the workpieces. Evaluate whether the coatings can be eliminated or removed prior to entry into the metalworking operations. With good production control, it is often possible to make parts and apply final protective coatings without in-process protection.

The second most common source of organic contamination in coolants is worker trash such as cigarette butts, food scraps, spit, etc. A strong training effort should be used to educate workers that plant productivity and profitability partially depend upon coolant cleanliness.

Stress that it is better to keep contaminants out than it is to have to remove them from the coolant later.

Another source of food for bacteria and fungus are coolant additives. Active chlorinated, phosphorized or sulfurized cutting oils should be avoided when possible.

Coolants can support the growth of both aerobic (i.e. those that grow best in the presence of oxygen) and anaerobic (i.e. those that grow best without oxygen being present) bacteria. Aerobic bacteria cause most of the damage to coolant formulations as they chemically alter the base oils, emulsifiers and corrosion inhibitor in coolants to the point that they do

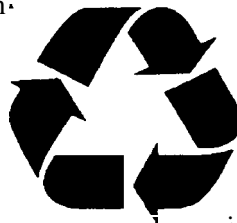

The term "recycling" is used in

this fact sheet to mean processing used coolant to be suitable for reuse. The processing includes contaminant removal and adjustment of coolant concentration and pH. Coolant recycling systems also may include automatic mixers and water purification capabilities.

not perform effectively. The presence of aerobic bacteria is frequently not recognized as being a problem since they do not cause odors. It is the anaerobic bacteria that cause foul odors and discoloration of coolants. Anaerobic bacterial growth will not occur until aerobic bacteria have first "damaged" the coolant. The presence of foul odors is indicative of severe bacterial degradation of fluid that has progressed to the point that the fluid is no longer recyclable.

Metal chips and fines from cutting and grinding processes contribute to microbial growth by providing a growth substrate or "breeding ground" on the bottoms of coolant tanks. Ideally, all metalworking machines should be equipped with conveyors and filters to continuously remove chips and fines. Unfortunately, most machines are not so equipped. In such

instances, it is important that chips and fines be removed manually from the coolant on a weekly or bi-weekly basis. As previously indicated, there should also be annual cleaning of total metalworking systems. The more often and more thoroughly that chips and fines are removed, the better coolant performance will be, both immediately and long-term.

An important way to minimize bacterial growth is to eliminate pockets in coolant systems, especially in sumps where coolant can stagnate:

- Round all internal corners.
- Fill seams and holes.
- Block blind passages.
- Eliminate any unused pipe runs.

If it is difficult to access the crevices of a sump, consider installing and using a sump that is external to the machine rather than part of the machine.

Surprisingly, it is not desirable to totally eliminate bacterial growth. Bacteria tend to suppress the growth of fungi, which are the slimes and semisolids on the interior of pipes and on the walls and bottoms of coolant systems. Excessive (too much and too frequent) application of bactericides tends to result in fungal infections, which are often more troublesome than bacterial infections in coolants. Even low levels of fungus tend to blind filters and rapidly plug coolant pipes.

 One of the worst things that a company can do is to locate metal cutting operations next to plating, painting, heat treatment or cleaning operations. Chemicals, as well as heat and high humidity, from such operations can affect coolant performance.

 Coolants should be protected from contamination at all times. They should preferably be stored indoors (at 50°F to 120°F) in closed containers, if possible. If outside storage cannot be avoided, cover the containers or set them on their sides to prevent water and dirt accumulation around bungs. Bulk storage tanks should have bottom drafts and drains to facilitate cleaning. Ideally, bulk storage tanks should be equipped to warm and circulate stored coolant.

8 REMOVE CONTAMINANTS CONTINUOUSLY

Even with the best prevention measures, some tramp oil, metal fines and process contaminants will be present in machine coolants. It is important to remove these materials before they build up and reduce coolant performance.

Contaminants may be removed by processing the coolant with an “in-line” (continuous flow) or an “off-line” (batch type) coolant recycling system. Both can be equally effective. Used coolant flows directly to a recycling system and cleaned coolant flows directly back to the metalworking machine with an “in-line” system. Used coolant must be physically removed from metalworking machines and returned after recycling with “off-line” systems. With both systems, the recycling systems consist of various combinations of filters, coalescers, separators, skimmers, and high speed centrifuges to remove tramp oil, fine particulate matter and bacteria.

“In-line” systems can require a significantly higher equipment investment than “off-line” systems due to the added cost of a centralized filtration system, which requires in-floor

COMPARATIVE PERFORMANCE AND COSTS OF COMMON COOLANT RECLAMATION EQUIPMENT

**Chip Wringers
\$5,000-\$10,000**

Chip wringers are low speed (up to 1,000 rpm) centrifuges that are used for removing residual coolant from metal turnings. Chip wringers are used to recover coolant for reuse and to make metal turnings more recyclable. (Some metal recyclers will not accept "wet" chips.)

Chip wringers are usually cost effective if chip generation rate is more than 2,000 pounds per week with ferrous metals or 500 pounds per week with non-ferrous metals.

Chip wringers are available in both batch and continuous operating models. Batch models are about one-half the cost of continuous operating models but require manual labor for operation.

**Coalescers
\$1,000-\$5,000**

Coalescers help the formation of tramp oil globules in coolant and, thereby, assist in separating tramp oil from the base coolant. They accelerate the formation of floating oil layers and facilitate skimming. Coalescers work best with low speed coolant flow. The equipment consists of closely-spaced oleophilic (i.e. oil attracting) material, through which the coolant is pumped. Tramp oil collects on the oil-attracting surfaces, forming droplets that join together to form globules. The globules then float to the coolant surface. Coalescers remove non-emulsified oil, but not emulsified oils. The equipment is generally **not** self-cleaning and will require periodic removal of accumulated fines from the coalescing media surfaces and tank bottoms.

Coalescers do not remove metal fines. Large sized contamination and metal chips should be removed before coolant enters a coalescer to minimize clogging.

**Skimmers
\$250-\$800**

Skimmers remove floating tramp oil from coolant surfaces. Skimmers are most efficient when the coolant is still or is moving at a low flow rate-and is directed to the skimmer. Skimmers are available with disk or wheel and belt or rope oil adsorbent surfaces that are made with an oleophilic (i.e. oil attracting) material, typically polypropylene. The adsorbed oil is removed from the skimmer surface with "knife" blades or rollers, which direct the oil to a collecting tray. Floating skimmers are also available.

Skimmers are the most common type of equipment used to remove floating tramp oil from coolant. Skimmers should be used whenever metalworking machines leak large quantities of tramp oil to extend the time between required coolant recycling. Skimmers pick up some metallic fines but should not be relied upon for their removal. The presence of large quantities of fines on the skimming surfaces can result in degradation of skimmer efficiency.

**Gravity Separators
Up to \$2,000**

Gravity separators are tanks in which dirty coolant is allowed to be idle for several hours. Non-emulsified tramp oil floats to the surface and metallic fines sink to the bottom of the tanks. Usually, the equipment has one or more weirs, which keep dirty and cleaned coolant separated. The equipment usually includes a means for conveying accumulated metal chips and fines from the bottom to a recycling receptacle.

Gravity separators may be equipped with heaters to more effectively control bacterial growth.

COMPARATIVE PERFORMANCE AND COSTS OF COMMON COOLANT RECLAMATION EQUIPMENT

High Speed Centrifuges
\$20,000-\$30,000

High speed (4,000 + "G" rpm) centrifuges are used for separating emulsified and non-emulsified tramp oils, metallic and non-metallic fines and bacteria from coolant. The equipment purifies coolant to the greatest extent possible with present day equipment. Centrifuges have little solids holding capacity but are available in both manually cleaned and self-desludging models. Manually cleaned centrifuges are normally used in "off-line" or "batch" type recycling systems. They require good "prefiltration" of solids if frequent cleaning is to be avoided. Automatic, self-desludging centrifuges are normally used in "in line" recycling systems.

High speed centrifuges remove 50 to 80 percent of bacteria present from coolants. Some centrifuge systems include in-line heaters or "pasteurizers" in the systems for thermal destruction of bacteria.

Filters, Cartridge
\$250-\$1,000

Cartridge filters with fabric or paper media are used to remove metallic fines down to about 5 microns in size from coolants. This equipment should only be used after tramp oils have been removed to avoid plugging.

Note: Diatomaceous earth should be used for coolant filtering. It filters too finely and will remove desired chemical additives from coolants.

Sump Cleaning Units
\$3,000-\$10,000

Sump cleaning units are large liquid vacuum machines, typically having two storage tanks, one for dirty coolant and the second for clean coolant. The basic functions of the equipment are to: (1) "suck" used coolant from the sump of each metalworking machine; (2) transport the dirty fluid to and from centralized recycling equipment; and (3) refill the machine sump with cleaned coolant.

Some sump cleaning units have "On Board" recycling capabilities. With this type of equipment, recycling takes place while the sump cleaning unit sits next to a metalworking machine. The coolant is drawn into the unit by vacuum, processed by coalescing, filtering or centrifugation and then returned to the sump.

Filters, Belt or Gravity Bed
\$3,000-\$5,000

Belt or gravity bed filters are commonly used to remove metallic fines from machine coolants. Belt filters slowly unroll a length of media in the path of used coolant flow, continuously providing an area of new, unused media. Belt filters do not clog like cartridge filters due to the continual replacement of used media. Belt filters typically remove particulates down to about 5 microns in size.

A list of coolant reclamation equipment suppliers with sales representation in Michigan is available from the Office of Waste Reduction Services. Ask for the "Machine Coolant Management Systems" equipment list.

It is recommended that metalworking companies thoroughly investigate machine coolant recycling systems before buying them. Ask your coolant suppliers for recommendations. Ask equipment suppliers for the names of customers who are using their equipment and take the time to check them out. Do not buy equipment solely on the basis of lowest cost.

flumes and clean coolant distribution piping. (See Figure 2). The centralized filtration system provides continuous, automated removal of chips, however, which will usually pay for itself on a long term basis.

“Off-line” or batch systems have the same basic coolant recycling capabilities as “in line” systems but require manual removal of chips, swarf and dirty fluid. Depending upon production rate and operating conditions, used coolant and contaminants must be removed from each metalworking machine every two to six weeks. The machine sump is immediately filled with cleaned, recycled coolant so that the machine can be returned to production. A sump cleaning unit is used to remove dirty coolant from machine sumps, transport the fluid to and from a centralized recycling system and return the clean fluid to the machine (see Figure 3 on page 13).

Coolant recycling equipment needs should be based on the volume of coolant in use, whether the coolant is contained within individual machine sumps or in one or more central filtration systems, the fineness of filtration needed for optimum cutting or grinding performance and the amount of money available for equipment purchase. There are trade-offs between equipment costs,

speed of recycling and quality of fines and tramp oil removal. For example, the same volume of coolant may be processed in 24 hours with a \$1,000 gravity separation system, in 1 hour with a \$3,000 coalescing system or in 5 minutes with a \$20,000 high speed, disc bowl centrifuge. While the settling and coalescer systems will remove most of the non-emulsified tramp oils, high speed centrifuges will remove both emulsified and non-emulsified tramp oils (as well as very fine particulate matter and most bacteria). Thus, the more costly equipment removes contaminants more quickly and thoroughly, which means that the recycled coolant will be usable over a longer period of time.

Usually, recycling takes place in the following sequence:

- a. Remove large metallic chips - with a conveyor, magnetic separator or manually.
- b. Remove gross contaminants - with a screen:
- c. Remove tramp oils - with a skimmer, coalescer or high speed centrifuge.

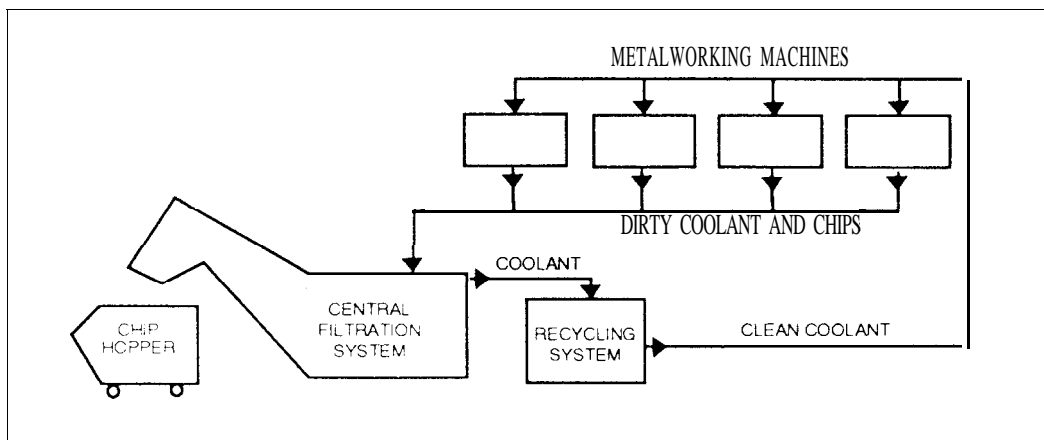

*Figure 2
“In-Line” Coolant Recycling System*

- e. Remove bacteria and fungus - with a high speed centrifuge, elevated temperature exposure or bactericides.

The key to successful contaminant removal is to sequentially remove unwanted materials while avoiding rapid plugging of filter media. Skimmers and coalescers do not remove tramp oil completely, and even trace amounts quickly foul fine filtering media. Metallic fines can also plug fine media. Although filters are available with back-washing capabilities, they are not 100 percent efficient and media must be eventually replaced. The design of trouble-free coolant recycling systems can be a real challenge.

The extent to which metallic fines should be removed from coolant is governed by the type of machining to be performed. In general, fines are removed down to about 75 microns for coolants used for rough machining operations. Coolant used for finish machining will typically require the removal of particles down to about 10 microns. Very fine machining, such as polishing and honing, may require filtration down to 1 microns. Filters that remove fine particles cost somewhat more than those that remove coarse particles and will require more frequent media change.

Thermal heat can be used to kill some bacteria. However, there is evidence that some strains of bacteria become resistant to heat fairly rapidly.

On a regular basis, at least annually, coolant systems should be thoroughly cleaned. This is in addition to the weekly or bi-weekly cleaning previously discussed. Usually, as bacterial count increases, emulsion type coolants change color from milkish white to gray and the odor of hydrogen sulfide becomes pronounced. Coolant systems should be cleaned before such symptoms fully develop as such "spent" coolants cannot be restored to useful condition. Coolant life can be extended up to 3 times with proper cleaning.

The suggested procedure for thoroughly cleaning coolant systems is:

- a. Pump the coolant from the system.
- b. Thoroughly remove chips and fines. Sump cleaning equipment helps to make this task easier and more productive. Typically, cleaning time can be reduced 50 to 80 percent with effective sump cleaning equipment.

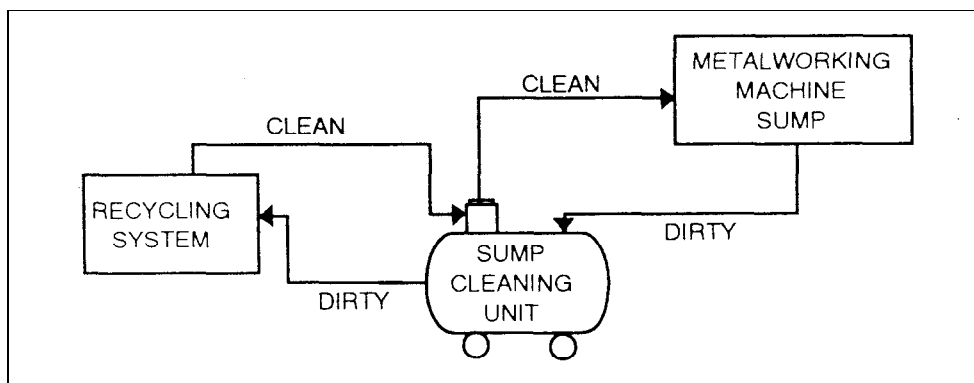

Figure 3
"Off-Line" Coolant Recycling System

- c. Wipe oily residues and fungal slimes from all surfaces, including those exposed to splashing or misting of coolant.
- d. Fill the system with a good quality cleaner, one recommended by your coolant supplier. Use enough cleaner so that it can be circulated through all coolant lines, flumes, etc. However, the system need not be filled to the brim.
- e. Circulate the cleaning solution through the system for 2 to 3 hours.
- f. Wipe or brush cleaning solution or a bactericide recommended by your coolant supplier on surfaces that are contacted by coolant during machine operation, including those on which coolants are splashed or misted.
- g. Pump cleaning solution out.
(Note: It may be possible to reuse the cleaning solution in several coolant systems provided it has not picked up significant amounts of tramp oil, metallic fines and bacterial/fungal solids.)
- h. Wipe cleaning solution or bactericide off all surfaces and rinse with clean water.
- i. Circulate clean water through the coolant system for 1/2 to 1 hour. Repeat the cycle until the water comes out clean to ensure that all residues have been removed.
- j. Immediately recharge the system with new or clean recycled coolant. If recharging is not immediate, exposed metal surfaces may corrode.

“In-line” recycling systems, which supply coolant to several metalworking machines from one large sump, often pose larger bacterial problems than “off-line” systems with individual sumps beneath each machine. This is because the connecting piping provides additional opportunities for bacterial growth and because the higher speed pumps used on larger systems tend to emulsify tramp oils. It is necessary to exercise more stringent cleaning procedures on central systems to prevent high bacterial growth than with individual machine sumps.

⑨ **AVOID OVERUSE OF BACTERICIDES**

Bactericides are poisonous to bacteria. Many are poisonous to higher forms of life too. Strong bactericides should not be used routinely to control bacterial growth. The bactericides will be present when it is time to dispose the “spent” coolant and the mixture may have become a hazardous waste. Disposal options will then be limited. Also, disposal costs will be much higher. Accordingly, select and use bactericides very judiciously. It is much better to control bacterial growth by withholding food, as was noted previously.

Indications are that most bactericides are more effective when used to “shock” coolant systems than when added on a regular basis. It appears that bacteria adapt to repetitive use of diluted or small doses of most bactericides.

⑩ **DISPOSE “SPENT” COOLANT WISELY**

A primary objective of coolant management should be to minimize toxic substances in the coolant so that the material need not be disposed as a hazardous waste. Disposal costs for hazardous wastes are 2 to 3 times higher than the costs for nonhazardous wastes. Avoid using coolants with toxic additives. Also, make sure that solvents, cleaners, paints and plating chemicals are not mistakenly mixed with “spent” coolant.

Ultrafiltration (UF) units are very efficient for removing trace amounts of oil from water. They are successfully used to prepare contaminated water for reuse or disposal into sewers that are connected to a publicly owned wastewater treatment plant (POTW).

Note: It is recommended that a representative sample of contaminated water be supplied to the UF equipment supplier for test processing before purchasing a system. A sample of the “clean” water (permeate) from the UF unit should then be sent to your POTW to determine whether it can be freely discharged into your sewer system or whether a discharge permit will be required.

In addition to “dewatering” coolants, ultrafiltration can be used to remove oil from aqueous cleaning solutions and “mop” water to enable their reuse.

Hollow tube membrane technology seems to offer the best resistance, spiral wound technology offers intermediate resistance and hollow tube technology offers the least resistance to particulate fouling (or plugging). Polysulfone membranes provide good oil/water separation but they will be destroyed if contacted by chlorinated solvent. Membranes of polyacrylonitrile provide excellent oil/water separation and are unaffected by chlorinated solvent. However, polyacrylonitrile membranes are only available in spiral wound modules and have only moderate resistance to plugging. It is recommended that skimmers, coalescers or high speed centrifuges be used to remove most of the oil from coolants, cleaners and other waste waters before entry to UF membranes to minimize fouling.

Ultrafiltration units cost \$3,000 to \$10,000 for units capable of processing 100 gallons per day of waste fluids and \$10,000 to \$20,000 for units with 300 to 500 gallons per day capacities.



The State of Michigan prohibits the disposal of oil wastes onto the ground or into surface or ground waters. State regulations provide only two ways to dispose of used oil: (1) recycle into new oil products; or (2) burn the material and recover the thermal energy. It will be necessary to test “spent” coolants before disposal to ensure that they have not been contaminated with hazardous wastes.

For lowest disposal costs, it is necessary to separate emulsion type coolants into oil and water fractions. It does not make sense to pay to have water disposed. Also, the value of the oil increases with decreasing water content, as oil reclaimers' pick-up fees decrease with increasing Btu value.

There are three ways to separate oil and water. The most preferred and least expensive is to "split" coolants chemically. The second is to evaporate the water with heat. The third, and least desirable method--because solid waste is created--is to coagulate the oil with a polymer.

Chemical splitting is done by adding a sulfate salt (e.g. Epsom salt) or sulfuric acid to coolant. These materials destroy emulsions. Emulsions split into an oil layer and a water layer, with the oil layer on top. The oil layer can be decanted relatively free of chemicals and contaminants. Sulfates from the chemical additive will remain in the water layer. It may be necessary to run the water layer through a cartridge filter to remove solid contaminants and through an ultrafiltration system to remove trace amounts of residual oil before discharging the water to a sewer system.

An alternative to paying a waste hauler to take away used oil for rerefining or for use as fuel is to burn the waste in-house for steam or heat generation. In-house combustion of waste oil with energy recovery is in accordance with hazardous waste regulations. However, companies should check with the Air Quality Division of the Michigan Department of Natural Resources to determine whether the combustion products will be within clean air regulation requirements and whether an air permit is needed before investing in burning equipment.

Some companies use steam or electrically heated evaporators to vaporize water from

used coolants. It is less costly to vaporize the water than to dispose it through a liquid waste hauler. Before buying an evaporator, however, companies should investigate whether an air permit will be needed to operate the equipment.

Use of polymers to coagulate the oil in spent coolants is somewhat more costly than chemical splitting or thermal evaporation. Not only are the polymers costly but also the coagulated mix must be disposed in a landfill.

CONCLUSION

The term *coolant management* means careful selection and control of machine coolants from point of purchase to point of disposal. Implementation of coolant management will save money in every metalworking shop.

For more information, contact the:
 Office of Waste Reduction Services
Environmental Services Division
 Michigan Departments of Commerce and Natural
Resources
 P.O. Box 30004
 Lansing, Michigan 48909
(517) 335-1178

Toll Free:
1-800-NO-2-WASTE

March 1994

#9402

The Office of Waste Reduction Services is a partnership between the Environmental Services Division, Department of Commerce and the Waste Management Division, Department of Natural Resources.

Printing Authority:	P.A. 148 of 1993
Total Copies:	2,000
Printing Cost:	\$765.00
Cost Each:	\$.3825

