

## **Waste Prevention:**

---

# SOURCE REDUCTION

# NOW

**How to implement a  
source reduction  
program in your  
organization. This  
manual complements  
"Source Reduction Now,"  
a training video.**

**Author:**

**Kenneth Brown**

**Graphic Design/Illustration:**

**Paul Andre**

**Original Printing February 1993**

**Reprinted January 1996**



**520 Lafayette Rd. N., Second Floor  
Saint Paul, MN 55155-4100**

**phone 651-296-3417**

**fax 651-215-0246**

**toll-free 800-657-3843**

**<http://www.moea.state.mn.us>**

## Acknowledgement

Developing the information contained in this manual was a collective effort. Special thanks are due to the managers and staff of the Sawmill Inn, the Itasca Medical Center, the Herald Review and the Itasca County Courthouse of Grand Rapids, Minnesota. With OEA assistance, over a hundred people were involved at these organizations to learn how to implement and measure source reduction programs.

Almost two hundred people were contacted across North America to help develop a source reduction logo. Correspondence and conversations with these people was invaluable.

Over thirty people were involved in the review of different parts of this manual. All comments were helpful. Special appreciation goes to the staff of Dakota County, Olmsted County, the City of Fridley, the Minnesota Pollution Control Agency, the Metropolitan Council and the Office of Environmental Assistance for ongoing dialogue and support throughout the development of this project.

## Copyright information

© 1993 by the Minnesota Office of Environmental Assistance (OEA). The OEA gives permission for reproduction of part or the whole of this manual provided acknowledgement is given to the OEA. For example, if Chisago County pays for reproduction and distribution to its citizens, the sentence "Presented through cooperation between the Minnesota Office of Environmental Assistance and Chisago County," is appropriate. The county's logo may also be used.



## Waste Prevention:

# Source Reduction Now

## How to use this manual

The manual is arranged in sections that follow the changing needs of an ongoing program. The sections can be distributed individually to address specific needs as they arise. **An outline of steps** and **Detailed steps** (marked with 🔄) contain the basic elements to implement a source reduction program.

**Introduction** (pp. 1-6) provides general information on solid waste issues. It identifies problems and provides reasons for implementing a source reduction program. Routing this section helps employees recognize the need for a program.

**Waste management methods** (pp. 7-8) informs staff of the ways their waste may be presently managed. If this information is routed after employees have read the introduction, it generates interest for the program.

**Source reduction** (pp. 9-12) defines source reduction in a comprehensive manner. It provides people with common ways to prevent waste at the source.

🔄 **An outline of steps** (pp. 13-14) is for management and people interested in developing a reduction team. These two pages provide a brief overview of the steps necessary for a successful program.

🔄 **Detailed steps for a program** (pp. 16-28) is useful for everyone organizing a program but is required reading for the facilitator of the team. It describes strategies to deal with common barriers and describes specific opportunities to overcome those barriers.

**Measurement** (pp. 29-40) describes methods for those wishing to quantify the results of their program. In addition, the information can be used to evaluate the waste generated through the use of different products. This section is designed for people who evaluate products and waste.

**Purchasing guidelines** (pp. 41-48) discusses factors to include in purchasing decisions to reduce waste. It should be distributed to people who make purchasing decisions as a part of their source reduction program.

**Case studies** (pp. 50-88) shows what can happen when programs take effect. It details cost savings and waste prevented at three organizations that used the model described in this manual. Though useful to everyone in an organization, case studies have proven particularly valuable for management in appraising the feasibility of implementing a source reduction program.

**Appendices A, B and C** give information on volume and weight conversions, lighting and waste audits. These are for people who evaluate and target products for source reduction.

**Appendix D** helps team members realize the potential for preventing waste in their communities. The information outlines financial benefits for a community as a whole. It, along with other articles on source reduction, should be routed after the program is in place. This section is also useful to local governments.

**Appendix E** fact sheets should be routed to employees during the program. Use them, as well as other articles, to keep the awareness of the program high.

**Poster samples** for promotion of source reduction programs. These may be copied or used for gathering ideas.

# Source Reduction Now Video

**Source Reduction Now Video** is a 12-minute OEA training video designed to accompany this manual. The video provides an introduction to the concepts of source reduction, and explains how to set up a source reduction program in a commercial, industrial or institutional organization.



**Borrow:** A copy can be borrowed from the Minnesota Office of Environmental Assistance. If you plan on using the video to help implement an organization's program, borrowing the video for a couple of weeks makes sense. It is then returned to the OEA for reuse. Call the OEA's Education Clearinghouse at 651-215-0232 or 800-877-6300 toll free.

**Purchase:** The video can be purchased from the OEA for \$8.50 (tax and shipping included). This option is best if the video is needed for continued use. Send a check or money order made payable to the "Minnesota OEA" to: Source Reduction Now Video, Minnesota Office of Environmental Assistance, 520 Lafayette Road N, 2nd Floor, Saint Paul, MN 55155-4100.

**Buy in bulk:** If more than five videos are needed it is cost-effective to order from the Duplication Factory directly by phoning 612-448-9912. This company provides original jackets and quality copies made from the master videotape.

# Contents

---

<b>Introduction</b>	<b>1</b>	<b>Appendix A: Commonly used formulas</b>	<b>87</b>
• Graphs	5	<b>Appendix B: Compact fluorescent savings</b>	<b>88</b>
• Waste Management Methods	7	<b>Appendix C: Waste Audits and surveys</b>	<b>89</b>
• Source Reduction	9	<b>Appendix D: Benefits of funding community source reduction programs</b>	<b>94</b>
<b>An outline of steps to implement a program</b>	<b>13</b>	<b>Appendix E: Fact sheets</b>	
<b>Detailed steps to implement a program</b>	<b>15</b>	• <i>Source Reduction</i>	
<b>Measurement of source reduction</b>	<b>28</b>	• <i>Popular ways for businesses to reduce waste</i>	
• Product-specific	28	• <i>Prevent Waste: A source reduction checklist</i>	
• Facility-specific	37	• <i>Packaging: Reducing waste and cost</i>	
<b>Purchasing guidelines</b>	<b>40</b>	• <i>Source-reduced and reusable transport packaging</i>	
Source reduction purchasing guidelines chart	46	<b>Posters for promotion of programs</b>	
<b>Case studies</b>	<b>48</b>		
• Hospital	49		
• Community newspaper	65		
• County courthouses and garages	72		

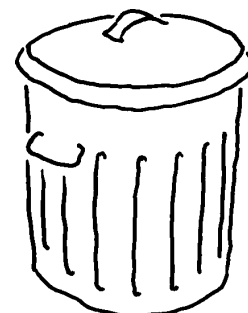

## Waste Prevention:

# Source Reduction Now

## Introduction

Preventing waste at its source — source reduction — is listed as the nation's highest priority among all ways to manage waste. Yet the extraordinary growth of our waste stream shows that creating waste, rather than reducing it, is more popular. It's also clear that the amount of money spent "disposing" of waste dwarfs the amount spent to reduce it. Why? Is source reduction one of those ideas that looks good on paper but doesn't work in the real world? If our words about source reduction are ever to change into action, then we must answer this question: "Does source reduction actually work?"

To explore this question, the Office of Environmental Assistance (OEA) undertook a series of case studies. At the core of the plan were two more questions. First, if a business or institution gets help to identify actions that reduce waste at the source, will waste generation change? Second, what is the best way to measure this change?

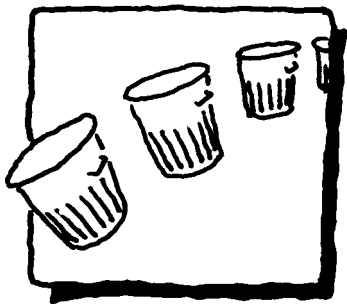

This manual summarizes almost three years of field research on these questions. It gives information on how to measure product and behavior changes that prevent the creation of waste. It gives guidelines on how to imple-

ment a successful source reduction program in an organization. It describes problems and suggests well-tested methods to solve those problems.

The OEA's field work demonstrates that when people realize how environmentally beneficial and cost-effective source reduction is, talk about it is changed into action. It demonstrates that source reduction not only works — it works well. It demonstrates that source reduction not only deserves to be listed first as our top waste management method, but it deserves to be used first.

## Identifying problems

Since evidence shows that reduction is an effective way to deal with waste, why aren't people rushing to find ways to do it? In a word, habit. Our habitual way of using resources and creating waste is hard to change.

Historically, in our land of "limitless" resources, incentive to conserve resources was minimal. In a land of abundant space, little incentive existed to change traditional disposal methods. Dumping and open burning have been popular ways to deal with waste for a long time. Not realizing the pollution problems we caused, these methods continued.

The problems dumping and open burning created are more apparent now for two main reasons.

### 1. The nature of our waste changed.

The past four decades ushered in a new era of "disposables." Consumer demand for convenience, the widespread use of new packaging, and producer marketing swelled our production of waste. Many products are now less durable and repairable. In addition, mod-

ern-day products often contain more hazardous substances.

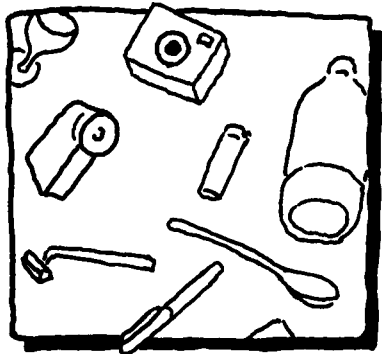

## 2. The number of products consumed increased.

More people are using more products. Population increased from about 150 million people in 1950 to almost 250 million people in 1990. Each American generated about two pounds of waste per day in 1950. Today we each generate more than four pounds per day.

More and more products for more and more people stimulated the economy, but unfortunately our habitual ways of using resources and producing waste created problems.

We discovered that we were using natural resources faster than ever before and our domestic supplies of many resources, particularly petroleum, metals and forests, were limited. In addition, increased population and development within other countries caused increased consumption and demand for resources.

We discovered that millions of relatively short-life products and packages created unforeseen volumes of waste. Some modern landfills now cover more than 2,000 acres.

We discovered that the polluted water, called leachate, that seeped from our dumps into ground water was potentially contaminating our drinking water. We discovered that

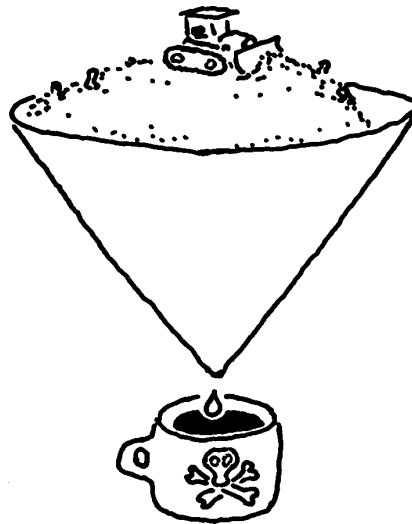

great costs and hardships were caused by our traditional methods of managing waste.

## Recognizing problems led to questions

### Is all this waste necessary?

To answer this question we looked at similar countries with growing economies.

Work by the Congressional Research Services (McCarthy 1991) shows that the United States generates four pounds of waste each day for each person in the country. Germany and Japan, industrialized nations which have comparable standards of living, generate about two pounds of waste each day for each person, just half of what we generate. The information casts doubt on the premise that large amounts of waste are necessary for a healthy economy.

Citizens are also asking questions. Hans Beckman, a German veterinarian touring here in 1976, had this to say about cultural attitudes toward waste. "Americans seem so wasteful," he said, concerned. "But then

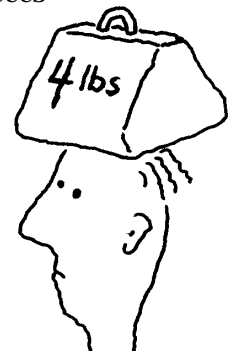

again, America has cheap resources. Germany used up her cheap resources 100 years ago. We pay a premium for them now. So does Japan. To compete with you, we have to use them more efficiently. I wonder how America will do when you have to start importing resources like we do, when the playing field gets even?"

Observations like these showed that different countries have different attitudes about waste. People raised with a need to import resources design, manufacture and use products differently from people who perceive resources as unlimited. Single-use aluminum beverage cans never caught on in Germany; reusable, refillable beverage containers are still prevalent.

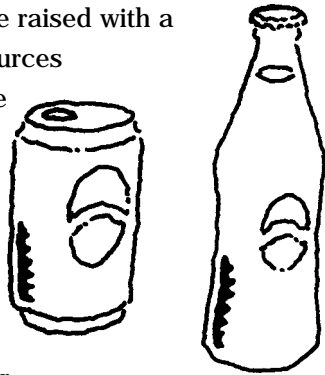

### Can our economy benefit through source reduction?

Recently, Americans began to realize the economic and environmental consequences of waste. The more waste produced to accomplish any task, the less efficient the process. The less efficient the process, the higher the environmental and economic cost.

The economy benefits through source reduction because less waste means more efficient use of resources and manufacturing processes, increasing competitiveness. Manufacturers are learning that reducing solid or hazardous waste in any manufacturing process usually lowers costs.

The need to use resources more efficiently and produce less waste is being felt in the marketplace. The marketplace will decide which products do this best.

Some businesses may object to source reduction if the product they manufacture is one that is viewed as more wasteful than a competitor's. Resistance to changing markets is not new. Due in part to resistance to change, some manufacturers of buggy whips didn't make the transition to leather gaskets and fittings for automobile production. Others did. Some buggy manufacturers decided not to make automobile carriages. Fisher was one that did, and "Body by Fisher" is an example of the success that can come through flexibility.

Many companies are developing products to fit today's "green" market. Baxter, a manufacturer of hospital products, now makes single-use and reusable surgical drapes. Papermate is increasing sales of its refillable "flexgrip" pen for the office. The number of companies remanufacturing copier toner cartridges is growing. Businesses are requesting reusable frames for forced-air filters. Caterpillar Tractor, Xerox and other companies are offering rebuildable rather than disposable components.

The marketplace is changing in response to long-term environmental and economic pressures. Economic opportunities come with market changes. These changes show that people care about the consequences of waste and are making purchases accordingly. Manufacturers, retailers and consumers can all benefit from source reduction, because efficient use of resources allows for long-term, sustainable economic development.

### Can the environment benefit through source reduction?

In addition to increasing efficiency and lowering costs, more and more companies are reducing waste because it helps protect the environment. The environment benefits through source reduction because as resources are



used more efficiently, fewer resources are needed to do the same job. The need to manage less solid and hazardous waste decreases the need for waste disposal. This also decreases pressure on the environment.

### **What can be done about the waste we do produce?**

Citizens recognized the wisdom of reusing resources rather than discarding them; recycling, which uses waste to make products, has become very popular. Incinerating waste (waste-to-energy) to reduce its volume and capture the energy contained in it has recently become a common waste management tool. Composting a portion of our municipal solid waste has become another way to utilize waste. However, managing waste is costly. The residual waste from all of these management methods still has to be landfilled.

Dumping has been replaced by landfilling. To meet our environmental criteria, new landfills must have liners and sophisticated drainage and monitoring systems to prevent ground water contamination. Crow Wing County in central Minnesota spent \$500,000 per acre to build such a landfill. The costs of siting, building, operating and providing for long-term closure, liability and care for a modern landfill can easily approach \$1 million per acre.

---

Today, our waste management issues are much more complex than those of the past. Old answers no longer work, and we're struggling to find new ones. So far, the new answers are expensive, but not as expensive as ignoring the problem.

Sometimes a simple answer is the best way to begin solving a complex problem. If we

simply produce less waste, our economy and the environment both benefit.

Common wisdom says that resources must be conserved for future generations to succeed and to preserve diversity of life. Further, if waste is reduced expenses for waste management can be reduced, freeing money for other programs and needs.

It is through the choices we make where we work, shop and live that these problems will either grow or diminish. Realistically, we have very old habits, and habits are hard to change. Historically, as nations depleted their resources, they conquered new lands to fuel their development. But today, there are no new lands. To fuel development today, the task is to use what we have more efficiently and create less waste.

Because we recognize these problems, habitual ways of viewing resources and waste are changing. They are changing because we see that our old habits will not carry our children into the future.



**The following graphs show what is happening in three important areas concerning waste.**

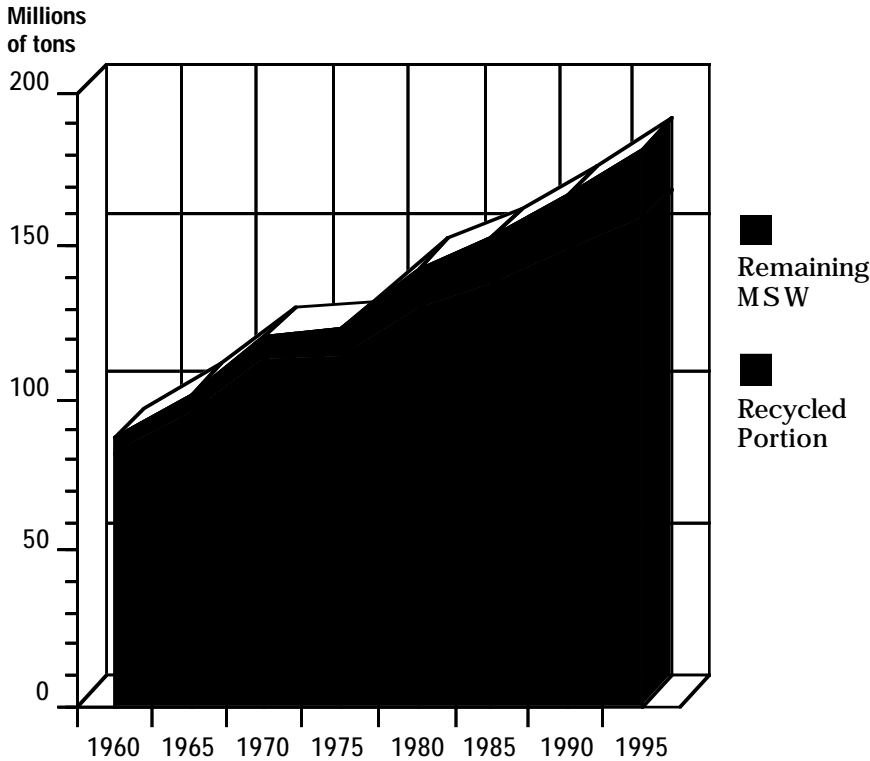

### Weight of U.S. Municipal Solid Waste

This graph shows we are increasing the amount of waste we must manage. The amount of municipal solid waste (MSW) America produces has more than doubled (87 million tons/yr to 180 million tons/yr) since 1960 for two main reasons: we generate more waste per person and we have more people. The dark band indicates the amount we're recycling.

Data and projections 1990 EPA Update

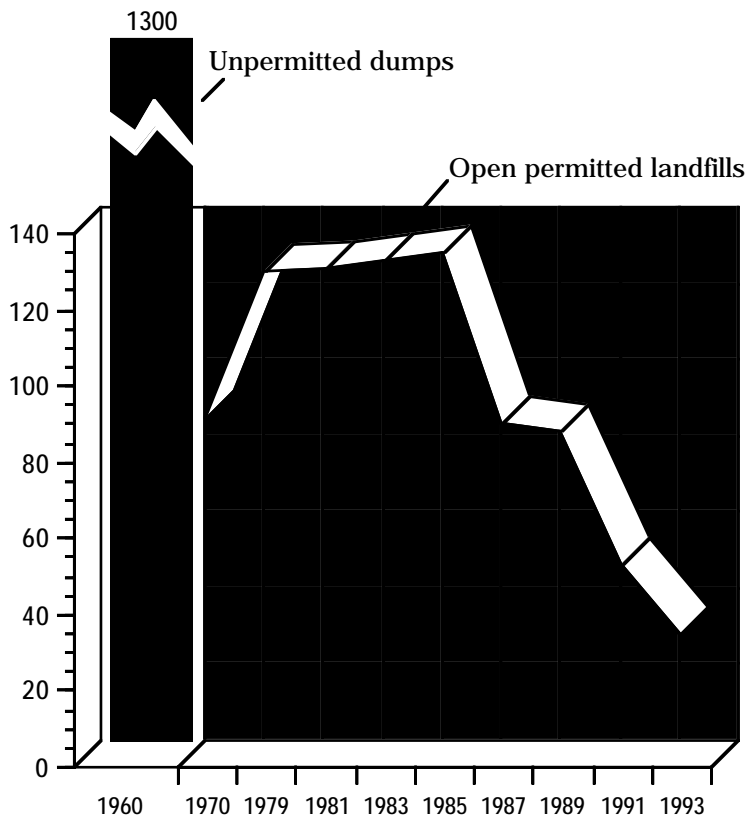

### Declining number of landfills in Minnesota

Reflecting a national trend, Minnesota landfills are closing.

The numerous, uncontrolled dumps of the past either closed or became regulated as landfills in the 1970s. Now the landfills that replaced the dumps are closing because they're full or are polluting ground water. Another factor leading to fewer landfills is the trend to close small, older, local landfills and replace them with large, sophisticated, regional ones.

\* Permitting of landfills began in 1970.

1993 figure projected by Minnesota Pollution Control Agency

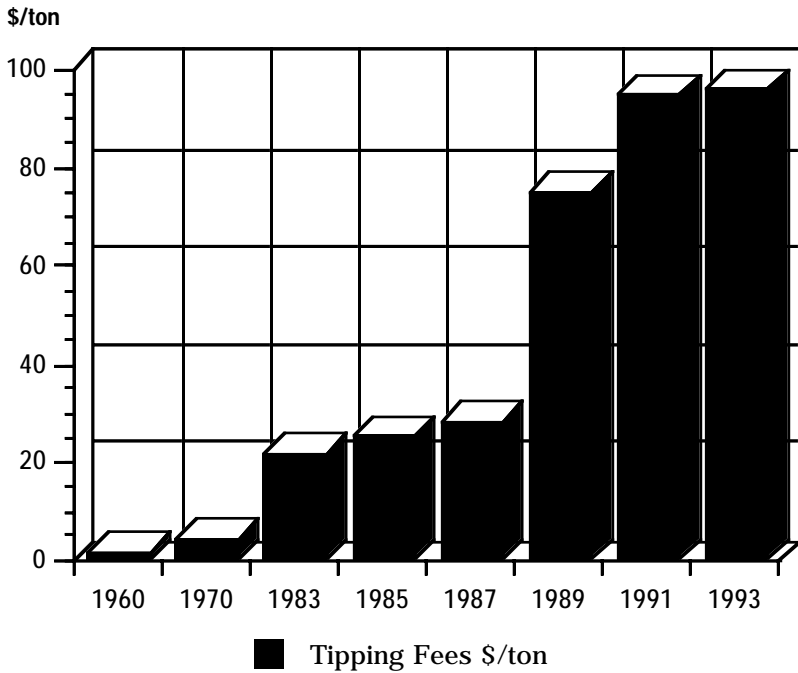

Hennepin County data

### Waste management costs

The cost of managing MSW is increasing. Open dumps of the 1960s and 70s were closed or converted to regulated landfills by the 1980s.

In the 1990s this county incorporated the true cost of programs for household hazardous waste, recycling, public education, waste sorting at transfer stations and efficient technology to manage remaining waste into its "tipping fee" (the fee charged to deposit or "tip" waste at the waste management facility.) If the costs are not paid through the tipping fee they usually are paid through taxes which can hide the cost of managing waste. The costs of collecting waste – estimated at an additional \$60.00 to \$90.00 per ton – are not shown.

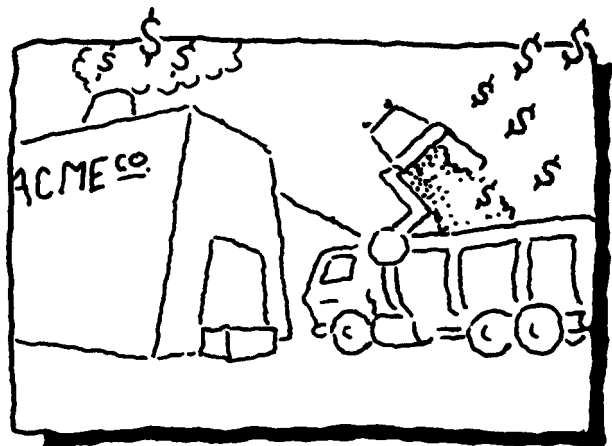

## Waste Management Methods

Before proceeding with a source reduction program, it is important to understand common definitions. These are working definitions rather than technical ones, and are used because they have proven most effective with people who staff reduction and recycling teams. OEA research shows that when program participants understand both the benefits and consequences of managing waste, they are more motivated to reduce it.

- **Source Reduction**

Source reduction is an activity that prevents waste at its source. It may also be referred to as waste prevention. Virtually everyone can make a choice to reduce waste. In a sense, people are the source of waste, for it is through their activities that waste is either generated or prevented.

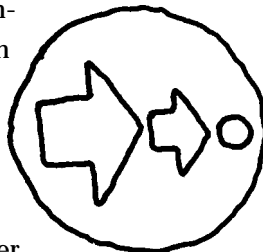

Source reduction includes:

- **Reducing** the amount of material used and/or the toxicity of the material used to accomplish any task.
- **Reuse** of a product in its **original** form.
- Use of **repairable, refillable, durable** products that result in a longer useful life.

It includes designing, manufacturing or using materials or products (including shipping containers and packaging) to reduce their amount or toxicity before they become waste.

The reduction of solid waste must not increase the toxicity of waste for the organization.

- **Recycling**

Recycling is a choice available to most people, but to be effective it requires a coordinated infrastructure. Recycling uses waste in lieu of virgin material in the manufacture of a product. It includes collecting, processing and remanufacturing recyclable material and buying recycled products.

Some products can be recycled over and over again into the same products. For example, an aluminum or steel can is commonly made into a new can. A glass bottle is commonly made into another bottle. Other products may only be recycled once. PET plastic bottles can be recycled to make carpet. Paper may be made into facial tissues.

For recycling to succeed, people must purchase products made with recycled content. Post-consumer content is that portion of a product made from material that has been used by the consumer, collected and remanufactured into the product. Commercial and residential collection programs make post-consumer material available to manufacturers.

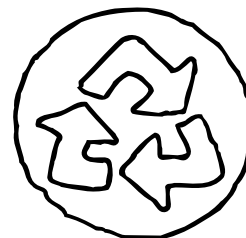

- **Waste Management Facilities**

The following three methods are best used to manage waste that is not reduced or recycled. Because of the scale of these facilities, decisions to build and operate these systems are usually made by local governments. The definitions are brief to provide a general understanding of these methods.

- **Solid Waste Composting**

Municipal solid waste composting is a controlled process that creates a useful humus-like material through the biological decay of organic waste. To obtain the highest grade of compost, noncompostable materials such as glass, plastic, metal and hazardous materials must be removed by either hand-sorting or mechanical means. Modern solid waste composting facilities use complex systems to speed up the natural process of decay to provide a useful product.

- **Waste-To-Energy Incineration**

Burning municipal solid waste in burn barrels, fireplaces or open piles releases hazardous compounds into the air without environmental control. Waste-to-energy incineration burns waste in a controlled, high-temperature (between 1,800 – 2,200 degrees F) specialized furnace. Heat created from incinerating the waste is used to produce energy in the form of electricity or steam. Recyclable and compostable materials should be removed from the waste before incineration. To create the safest ash and reduce hazardous air emissions, hazardous materials should also be removed. Incineration results in up to a 90-percent decrease in the volume of waste, meaning less waste must be landfilled.

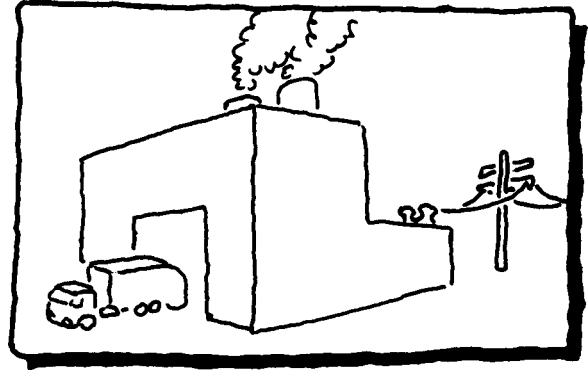

- **Landfilling**

Not all waste can be recycled, composted or incinerated. There is waste such as sludge, slag or ash that remains from these processes. These wastes must be properly landfilled.

Municipal solid waste landfilling is burying of waste at an engineered site. New landfills are required to be located above the water table and away from streams and underground water supplies. They must be lined with clay or synthetic barriers to prevent liquid from seeping into the environment. Collection pipes must be in place to draw off liquid that collects at the bottom of the landfill. This liquid, called leachate, must be treated before its release. When the landfill is full it must be capped with a water-impermeable top, effectively entombing the waste. Equipment must be present to monitor methane gas production and water contamination.

To conserve landfill space and resources, it is best to process waste before landfilling. Unprocessed waste, the waste that we put in dumpsters and trash cans, may someday be restricted from going directly into any MSW landfill. This stipulation has applied to all metro area counties since January 1990.

Recycling is a physical activity. People throw cans into recycling bins. Source reduction is not so concrete. To help make reusing and reducing “physical” and be as prominent as recycling, a logo is used.

 Reduce,  
 reuse, *then*  
 recycle.

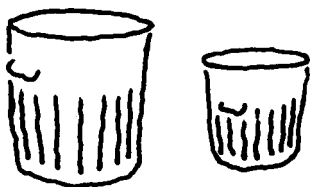

## Source Reduction

The alternative to processing waste is to prevent it.

Source reduction prevents waste at its source and is an effective tool for institutions, industries, commercial establishments and consumers. This tool can be used during any step in the creation or use of a product. Reduction can work during: Mining and processing raw material; growing and processing raw material; shipping; manufacturing; packaging; or use of the product.

Here are some ways to reduce waste through source reduction.

### ▼ Reduce the amount of material used to accomplish any task.

Office example: Many offices are using their computer networks to deliver memos. “Electronic mail” reduces the amount of paper that would otherwise be used to accomplish this task. In addition, when two printed pages are needed, one piece of paper is used, printed on both sides. For billing purposes, convenient send-and-return envelopes are preferred. One envelope does the work of two. More people are requesting quality, hand-crank pencil sharpeners because they don’t require motors or electricity.

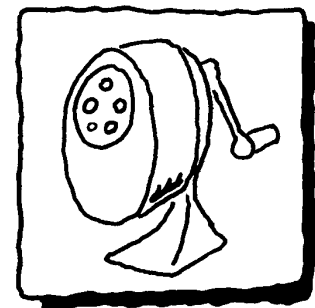

Consumer example: Sometimes smaller is better. Compact products can sometimes do the same job as larger ones. Smaller cars use

less resources than larger cars. If they are equally durable and repairable, much less material is used over the life of the compact product. Quality and value can come in smaller packages and produce less waste.

Commercial example: Sometimes bigger is better. This happens with what's called "economy of scale." Buses, for example, are less wasteful than cars – but only if the buses are effectively used by people who would otherwise drive cars. Multi-purpose buildings may be larger than buildings designed for a single purpose, but are less wasteful if well designed and managed. Also, buying in bulk creates less waste, but only if the product is actually used. If demand assures use, economy of scale uses less material to do a job, and bigger is better.

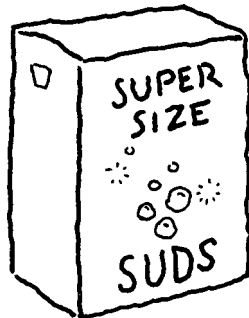

Industrial example: Production lines that filled containers relied on operators to shut down the process when filling levels were incorrect. Hundreds of partially filled cans were thrown out. Now, many factories use automated flow-control equipment that constantly monitors the filling, producing less waste. Increased efficiency uses less material to do the job.

### ▼ Reduce the toxicity of the material used to accomplish any task.

Institutional example: By looking for alternatives to typical X-ray developing solutions, Itasca Medical Center found a non-toxic product that worked as well with no decrease in processed X-ray film quality.

Industrial example: Progressive ink manufacturers are making good progress eliminating the use of heavy metals for pigments in ink. In addition, vegetable-based inks are replacing many petroleum-based inks, decreasing toxicity of the product. Less hazardous paints and stains are increasingly popular.

Industrial example: Many businesses are reducing the need for chemical solvents by increasing efficiency or finding substitutes. John Roberts Company of Minneapolis now uses a less volatile chemical for cleaning purposes and saves \$20,000 each year. Demand for less hazardous cleaners is growing.

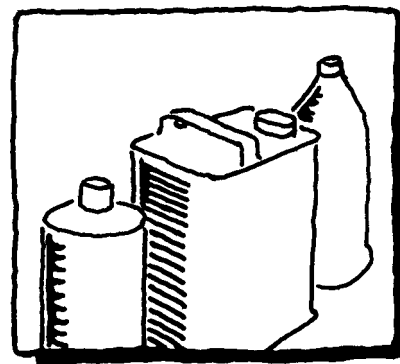

Consumer example: Solar powered calculators don't require batteries. Contrary to source reduction, some new products actually use more resources than their less "modern" counterparts. Many products, once free of C and D size batteries, now use them. Some cameras that automatically wind film use large batteries. The consumer cannot operate these cameras without batteries because no provision is made to wind the film manually.

Commercial example: Sometimes the "less toxic" choice is not clear. All compact fluorescent bulbs contain some mercury. Standard incandescent bulbs often contain small amounts of lead. Compact fluorescents commonly outlast incandescents 10 to one.

Which is best? Work done by an independent research laboratory, Rocky Mountain Institute (RMI) in Colorado, gives guidance. The research states that 75 percent less electricity is required to run a compact fluorescent bulb compared to an equivalent incandescent. Coal burned to generate electricity releases mercury. The amount of mercury required for the operation of fluorescent bulbs is minuscule when compared to the amount of mercury released to produce 75 percent more electricity. Consequently, RMI concluded that where coal is used to generate electricity, compact fluorescent bulbs result in the release of much less mercury. (It is worthy to note that even if hydroelectric or nuclear energy is used, 75 percent less would be needed to power fluorescent than incandescent bulbs.)

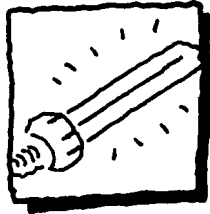

This research of “toxicity” reduction went beyond “use and disposal” of the product by the consumer to include the impact of energy requirements. Because of a lack of data, these attempts to define toxicity are rare. Usually, toxicity assessments are limited to a smaller part of a product’s life, such as the consumer’s own use and disposal of the product.

### ▼ Reuse products over and over again.

Many products designed for single-use can be reused.

Institutional example: The membership of Minnesota’s Legislative Commission on Waste Management (LCWM) periodically changes. When this happens, stationery printed with the members’ names becomes outdated. Rather than being recycled, the bottom and sides are trimmed to eliminate the names, leaving note

pads with LCWM letterhead that are used for appropriate correspondence.

Consumer example: The Tilsner Carton Company of St. Paul created a business by collecting cardboard boxes, cleaning them and selling them for reuse.

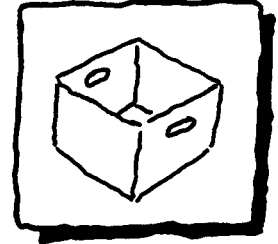

Industrial example: Burlington Northern Railroad approached the suppliers of their coupling air hoses and asked them if they would take them back for remanufacturing. One supplier agreed. Preference is given to this supplier. Thanks to this initiative, over 45,000 “like new” air hose couplings are reused each year by Burlington Northern.

Consumer example: Homeowners found they can use old carpet under landscape rock to prevent growth of unwanted vegetation. It also allows water to pass through.

Industrial example: Flint Ink Company of St. Paul gives its 55-gallon drums to a drum reclaimer that cleans and sells them for reuse.

Commercial example: Material exchanges are growing in number because businesses are finding that their waste may be a resource for another company. This reduces waste and saves money for everyone. Increasingly, “Find out another use, throwing out has little excuse,” is saving dollars, resources and preventing waste.

Commercial example: Businesses that sell reusable office furniture, appliances, computers or construction material reduce waste and are viable because of people’s effort to reuse.



▼ **Use repairable, refillable, durable products.**

The longer a product lasts, the fewer times it needs to be replaced.

Commercial example: Consumers and business people are requesting bids that include the cost of extended warranties. Products with long warranties tend to be repairable. Ease of repair is important.

Consumer example: Electronics is another area where short-life products are common today. Many are manufactured to be non-repairable and display this fact by using rivets instead of screws for fastening. The entire unit must be replaced when only a part of it needs repair.

Commercial example: Use of modular rather than individual parts is increasing. Toner cartridges for most photocopiers and printers are manufactured to be thrown out when empty. New businesses are now remanufacturing these cartridges for reuse. Many power tools contain rechargeable batteries that are not replaceable. When the battery will no longer hold a charge, the entire tool is designed to be discarded. Minnesota law requires that tools and appliances have an easily removeable rechargeable battery after July 1, 1993.

Consumer example: Many non-repairable, non-refillable products are now available. These include common items such as flashlights, ink pens, razors and cameras. They are usually less expensive initially than more durable alternatives. However, because they often have shorter lives they often must be replaced much more frequently than their counterparts. Consequently, they are often

more expensive to use and usually create more solid waste over time.



Once aware of the true costs and consequences of non-repairable products, many businesses realize that the purchase price rarely reflects the full cost. Thanks to people who reduce the amount of the material or toxicity of the material they use to do their jobs, industry and consumers alike benefit.

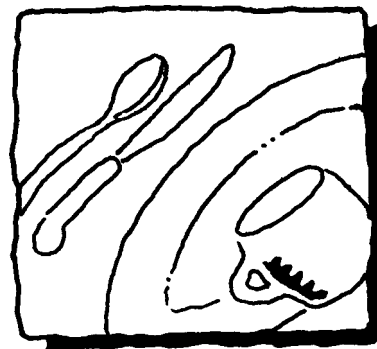
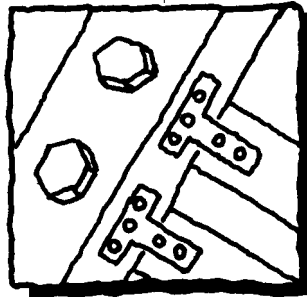

Washable dinnerware is making a return in many restaurants, cafeterias and schools.

The following outline summarizes eight steps to help implement a source reduction program within an organization. It is written for reduction teams and management.

# Outline of steps

## to implement a source reduction program

More and more organizations are finding that source reduction – preventing waste at its source – is an essential waste management method. Reducing the amount of waste generated is a practical way to reduce disposal and production costs as well as environmental impacts.

Source reduction does not require the construction of waste management facilities. What it does require is informed choices. Through the numerous small choices employees make each day, large amounts of waste can be prevented.

### Why source reduction?

The results of case studies by the Minnesota Office of Environmental Assistance (OEA) and volunteering organizations show that source reduction can substantially reduce waste and cost, and that the reductions are measurable. For example, the case studies show:

- ▼ Itasca Medical Center, a 143-bed hospital, prevents more than 245 cubic yards of waste and saves more than \$11,000 each year.
- ▼ The Grand Rapids Herald Review, a daily newspaper, prevents more than 25,000 pounds of waste and saves more than \$12,000 each year.
- ▼ Itasca County Courthouse prevents 10,000 pounds of waste and saves \$42,000 each year.

Source reduction can save money and the environment.

The following eight well-tested steps can help your organization implement an effective program. While written for larger businesses, they can be easily adapted for smaller businesses. A comprehensive description of these steps can be found in **Detailed Steps to Implement a Source Reduction Program** on page 15.

## Eight well-tested steps

### 1. Management declares support.

Senior management must understand the need to prevent waste. Management can show its support by:

- ▼ Announcing its authorization for the program.
- ▼ Developing a mission statement and goal with the staff.
- ▼ Seeing that periodic announcements and employee recognition take place.
- ▼ Staying concerned and involved.

By doing these things and by informing employees of cost and environmental waste issues, management communicates its concern to employees. This encourages involvement.

### 2. Select a reduction team.

It is important to get input from diverse interests within a business. If appropriate for the size of the business, managers may request a volunteer from departments such as purchasing, custodial, maintenance, manufacturing and clerical to form a team. The team members act as contacts for their departments. Businesses should ensure that team members represent all areas of the organization.

### 3. Select a facilitator.

The facilitator (or coordinator), needs strong organizational and communication skills as well as enthusiasm for the project. The facilitator collects information from outside sources, relays definitions and priorities, educates and tracks job assignments for the team.

## 4. Educate everyone.

There are three main phases to this step.

- ▼ First, management must be clear on waste issues and program goals. The mission statement is agreed upon with the team.
- ▼ Second, the facilitator teaches definitions, clarifies the mission statement and identifies waste issues and the program outline for the team. The facilitator provides focus. The team surveys all waste generated in the facility and becomes aware of its economic and environmental impact.
- ▼ Third, the team members take what they've learned back to their departments. Photographs taken during the facility waste survey help educate all staff members.

## 5. Brainstorm source reduction ideas.

Though many excellent ideas often come from the reduction team, many more ideas come from the entire staff. Avoid criticism of ideas in this step or ideas will not flow freely. Circulation memos or suggestion boxes work well.

The following questions can be used for brainstorming:

- ▼ Where can we reduce the amount or toxicity of the material used to accomplish anything we do?
- ▼ Can any single-use products currently in use be reused?
- ▼ Instead of single-use products, are there reusable products that do the same job?
- ▼ Are there alternative products that are repairable, refillable or more durable that give a longer useful life?
- ▼ Can concentrates or bulk purchases reduce our waste?
- ▼ Can we participate in a material exchange so that "waste" can be used as a resource?

## 6. Evaluate the ideas.

Prioritize the suggestions and evaluate them to determine how each suggestion affects waste and cost. Good record-keeping and a pocket calculator are usually sufficient to accomplish this. With several people researching different suggestions in cooperation with the purchasing department, this step can be accomplished quickly and decisions made as to which ideas to implement first.

## 7. Implement the most promising ideas.

Some suggestions can be implemented immediately. Use these ideas to add momentum to your program. This helps win support for more complex ideas, those that must be phased in over time. A month after implementation, the facilitator asks for comments from the staff on how the specific actions are working. The team writes up waste and cost changes achieved so far, and distributes the information to management and employees.

## 8. Continue the program.

Source reduction is an ongoing process. Periodic announcements on bulletin boards or in newsletters about the program help create enthusiasm. Give awards for innovative ideas. Inform new employees about the program. Remind staff about the suggestion box. Make sure that all implemented ideas are widely promoted.

---

Everyone has a part to play in reducing an organization's waste because everyone plays a part in creating waste. Involve everyone, senior management through entry-level employees, follow this outline, and your organization will very likely reduce waste and cut costs.



The following chapter provides details that are helpful when setting up a source reduction program.

It is written for the facilitator. In some cases, it may also prove useful to reduction teams and management.

# Detailed steps

## To implement a source reduction program

Actions taken to prevent waste have proven an effective way to reduce costs and impacts on the environment.

Implementing a program is rarely a complicated endeavor. The following steps to implement a facility-based program are detailed to address common issues of medium and large facilities. They can be tailored for use in smaller facilities. Experience shows that the basics remain the same no matter how large or small the organization.

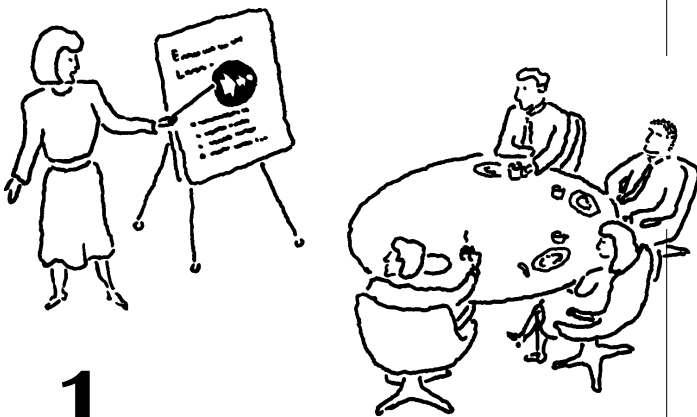

### 1 • Support from the top

It is senior management's role to support a structure that fosters implementation of the program. To foster broad-based support,

senior management should be aware and concerned about the waste generated by the facility. Their concern about waste's impact on business and community costs, as well as the environment, gives the program an excellent foundation to grow on.

If support from senior management is not strong, programs falter. Unless support of the program is demonstrated to employees, many do not assign necessary priority to waste prevention efforts. But how does management demonstrate that its support of its waste management program is strong? Here are some methods that have proven successful.

**Mission Statements:** Mission statements, done in cooperation with staff, are effective. They give importance to the program and define new company policy. The mission statement can be something as simple as:

We make a commitment to reduce the waste we generate through our use and disposal of products. We do this by asking:

- Where can we REDUCE the AMOUNT of material we use?
- Where can we REDUCE the TOXICITY of the material we use?
- Instead of single-use, are there other products we can REUSE over and over?
- Are there products that are REPAIRABLE, REFILLABLE or more DURABLE that give a longer useful life?

The waste we cannot reduce, we make a commitment to recycle. We also agree to solicit products that have post-consumer recycled content.

We further agree to promote our results to others so that more people may be motivated to reduce waste.

The goal described in the first sentence provides direction. The questions that follow provide guidance. The last sentence connects the program to others, giving additional importance to the mission. When people know their ideas will be available to others, their motivations increase and the program becomes more effective.

Mission statements are effective whether they are short or more detailed. In general, the shorter and more concise, the better.

**NOTE:** It is critical to the program that senior management endorse a mission statement. Involving staff in the creation of the mission statement can build teamwork.

The following actions by senior management are also helpful, particularly if plans for them are revealed to the staff early in the program.

**Goals:** Sometimes management can create a motivational goal for the organization by identifying:

- A target number of implemented ideas.
- A specific volume or weight of waste prevented.
- A stated reduction in contracted hauling service.

**Slogans:** “Preventing waste protects the environment and our livelihood.” or “Don’t waste resources, our lives depend on them.” are examples. Slogans help focus effort.

**Announcements:** Announcing the program in a company newsletter or memo emphasizes the campaign. Host a “kick-off” event.

**Recognition:** Written recognition of employees in these publications works well to keep motivation alive.

**Awards:** Staff meetings where awards are given to employees with winning ideas inspire more ideas.

**Updates:** Frequent updates at staff meetings and on bulletin boards demonstrate management support. Post the amounts of waste prevented.

Research conclusively shows that if management does not provide a supportive structure, program effectiveness is greatly diminished.

## Further action needed by management

▼ **Identify the scope of the program** – Senior management must also make the scope of the program clear. Are employees only to assess waste generated through the use of products in the organization, or are they to include waste generated by the manufacturers of those products? Lack of clarity on this difference can stop progress.

One company became bogged down when team members couldn’t get adequate information from distributors on the environmental consequences of the manufacture of reusable plastic versus reusable ceramic mugs.

Limiting the mission to “reducing the solid waste our organization generates” gives a workable parameter to the program.

▼ **Give Authorization** – Specific employees will be designated to attend meetings and research the feasibility of suggestions. If authorization is not clear, employees tend to put the program at the bottom of their workloads. Written authorization is most effective. Guidelines for estimating staff time are identified at the end of Step #3, page 19.

▼ **Senior management meets with the middle management** – Middle management – those managers that have daily contact with staff – must be made aware of their responsibilities. Each department has opportunities to reduce waste. For the program to succeed, senior management must effectively convey the program’s importance to middle management. This helps assure that middle management will carry an effective message to the staff.

▼ **Middle management meets with staff** – Personally explaining the mission statement at a staff meeting is effective. Informing staff of the program by placing notices in mail drops will not suffice by itself. Middle management must emphasize the importance of the program if they expect the staff to realize the organization’s commitment to reduce waste.

At the staff meeting, it is helpful if middle management gives some general information to staff. Commonly, people have no idea about the volume of waste that is produced at their organization or where it is disposed.

A request to the maintenance department or garbage hauler will provide information revealing how much waste is contracted for removal each month.

Your county government will connect you with your county solid waste department. This department knows how your county’s waste is managed as well as the costs of managing it. Solid waste personnel can often inform groups of how these costs have changed over time and about local environmental concerns.

These two pieces of information serve to connect activities at the organization with the community’s environment. When this information comes from management, it demonstrates that management is concerned about the community’s environment. After this information is known, middle management outlines the program to staff.

Use proactive program introductions like: “Our jobs are changing a little bit today. The impact waste has on the environment is probably costing us more than we know. It’s going to take a team effort to reduce our waste, and it can’t be done without you.”

Research shows that employees care about the environment. It is management’s job to provide a supportive structure so this caring translates into less waste.



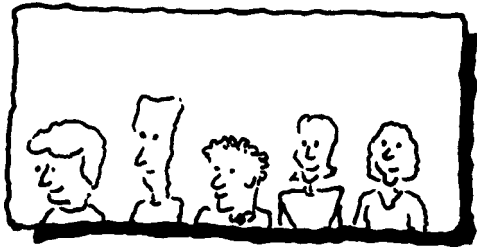

## 2. Select a reduction team

Small businesses may not need a formal team if coordinated “team work” can take place without one. However, if appropriate for the size of your business, establish a reduction team to assure success.

Each department — whether it be purchasing, maintenance, manufacturing, sales, food service, clerical, accounting or custodial — produces waste. Including one representative from each department gives invaluable perspective to the program. The designated people provide an immediate contact for others in their departments, facilitating the flow of information.

To provide structure, managers should request a volunteer and an alternate from each department. Volunteers who have a personal interest in the program work best. Since volunteers are staff, other personnel in the organization are typically receptive to the program because it is implemented by peers.

## 3. Select a facilitator

One person is selected from the team of volunteers to be a facilitator or coordinator. This person has a key job and needs strong organizational and team-building skills. On occasion, city, county or state reduction/recycling coordi-

nators can help facilitate individual programs. The facilitator investigates this option.

It is a critical part of the facilitator’s job to know the difference between source reduction and recycling. Actions suggested to reduce waste often include recycling. These suggestions are fine, but recycling uses waste — it does not prevent waste. The facilitator keeps the focus on preventing waste, but never discourages ideas for recycling waste.

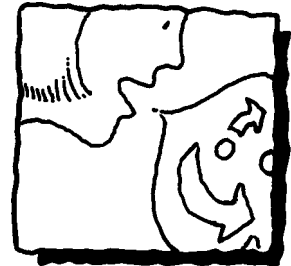

If the mission statement indicates, the facilitator limits the program to waste created through the organization’s use and disposal of products, and refers discussion of manufacturing processes and wastes to other forums.

The facilitator functions as a designated link to other organizations or agencies. It is useful to gather existing examples of reduction actions and educational materials from sources outside of the facility. Although there may be exceptions during the “evaluation” step, having one person designated as the recipient of this information minimizes the risk of duplication.

The facilitator posts or routes the agenda for each meeting to team members and management. It is important to list the people who are going to do specific tasks for the program. Individuals will research the feasibility of a particular product change. Detailing who is doing what enhances efficiency. Job assignments are tracked and progress is reported. A good way to keep senior management informed is to send a copy of each meeting’s minutes and agenda.

(Step 3 continued next page)

## ■ Labor for implementing a program

Staff time for implementing a program naturally depends on the complexity of the facility. There are guidelines to estimate labor.

- Senior management - One meeting held with middle management to formulate policy and begin the program.
- Middle management - One meeting with senior management and one meeting with staff.
- Staff - One meeting with senior or middle management. Employees usually brainstorm while they are doing their usual jobs. The time spent writing down ideas is negligible.
- Reduction Team - In general, the first three meetings are once a week, with subsequent meetings every other week. Programs normally show considerable results within six months. After six months, meetings can be once a month if effective communication is in place. Meetings are usually one hour in length.  
  
As suggestions come in, their feasibility must be researched. Team members most often volunteer to research suggestions familiar to them. If there are too many suggestions for the team to research among themselves, other staff members can help. Research involves telephoning for information, getting sample products and writing up waste and cost information. It is very important that research does not become the responsibility of too few people. The time required to research suggestions depends on the complexity of the product or process involved.
- Facilitator - The major time required of the facilitator is to write minutes, meeting

agendas and job assignments. In general, the facilitator should not research products in addition to these duties.

If program work is distributed well, none of these tasks need take so much time that it detracts from the employees' regular jobs. However, it is important to acknowledge that these individuals have taken on more work.

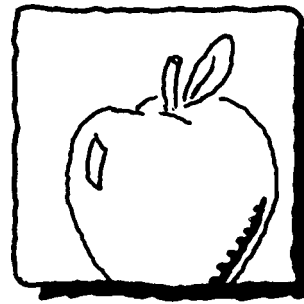

## 4. Educate

There are several phases to the educational portion of the program.

### Phase I – Senior Management

After elements listed in Step #1 are in place, the program can move on to provide detailed education for the reduction team. See to it that educational materials from state or county governments, other businesses and associations are made available to your team. Building on existing information saves valuable time.

### Phase II – Reduction team

Employees' efforts are important because without them, waste will continue. Employees' are often motivated to take action when environmental and economic waste issues are made clear.



Environmental motivation:

- ▼ Identify specific wastes generated by the facility.
- ▼ Demonstrate the fact that waste is not thrown “away,” it’s just thrown “out.” Show pictures of where the waste goes after it leaves the organization.
- ▼ Waste from the organization has impact on the environment. “If you’re not preventing waste, you’re wasting the world,” is one environmental slogan.

Economic motivation:

- ▼ Money spent managing waste is no longer available to be spent on social programs or on research and development. “Waste prevented can be a program saved,” or “Waste costs jobs,” are economic slogans.

## Team meetings

Any member of the team presents a review of:

- The information gathered from the county solid waste department on cost and environmental issues.
- The amount of waste generated by the organization.

The facilitator:

- Defines source reduction and differentiates it from recycling.
- Outlines details of the program. Walking through the outline of a program furnished with this manual has proven effective.

- Gives specific examples of source reduction accomplished by other organizations. However, the facilitator should refrain from prescribing actions for the organization in which he or she works. Research conclusively shows that it is more effective to ask good questions and let suggestions come from others.

Before the team brainstorms ideas about reducing waste, it is helpful for them to see firsthand what waste is generated by the organization. This is easily accomplished by touring the facility. Photographs taken during the tour will be used later in the program.

The team:

- Tours the entire facility.
- Takes notes and photographs.
- Should read “Details of Implementing a Source Reduction Program.”

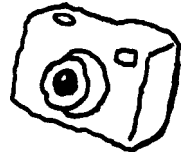

The representative from each department takes the rest of the team through his or her area. These are some of the questions that can be asked:

- ? What are specific wastes that are generated by this department?
- ? What comments do employees in the department have about their waste? (quantity, toxicity or necessity)
- ? Is the area free of easily avoidable waste such as spills, drips or inefficient use of materials?
- ? Are there strong odors, perhaps indicating leaks, overuse or spills?

? What are the waste materials found in the department's trash cans?

The answers to these questions are written on a survey form or note pad.

When the reduction team at the Sawmill Inn Hotel Convention Center did this, the networking that resulted between departments increased efficiency. In part: Reusable 30-gallon containers used in the kitchen were adopted for use by housekeeping; the maintenance department was able to learn of needs for lighting changes; old sheets were distributed as rags for use by all departments; and housekeeping relayed the use of refillable pump-spray containers to the maintenance department, replacing aerosols.

Sometimes the best ideas to reduce waste come from a fresh perspective. It is important that the entire team view the waste and product storage areas of each department.

After all departments are toured, a visit to the facility dumpster is in order. Upon surveying the collective waste, make note of its contents. **Sometimes, a day's waste can be set aside and surveyed before it is put into a dumpster. If safe, this waste can be dumped on a large plastic sheet for closer inspection and photographs.** This is an effective way to acquaint the team with the organization's waste. Clean-up is easy.

For educating and motivating the team, these simple waste surveys are effective. It should be noted, however, that unless repeated, these surveys only give a snapshot of the waste being generated. Many products may appear frequently but not daily, and these products may or may not be in evidence on the day of the survey.

If management wishes to track changes in the waste stream in detail, waste audits are used. In a waste composition audit, waste from departments or from the facility as a whole is separated, cataloged and weighed over a period of time. Professional waste management consultants are best used to accomplish this level of research. Results are helpful to target specific wastes. Though useful, money spent on waste audits is money not spent on actually reducing waste. People reduce waste; measurement does not.

**Additional team education** - If a landfill, MSW composting or incineration facility is conveniently located, a team visit is effective. The educational goal is this: Although we may throw out waste, it isn't thrown away. Our waste goes someplace for other people to manage. These waste management facilities are expensive to build and operate and they impact the environment. In addition, site visits show that a lot of natural resources are quite simply going to waste.

Some county solid waste officers can cooperate by contacting an organization's waste hauler and arranging to have the organization's waste dumped at a specific location at a waste management facility. When the team visits its waste "pile," education and waste surveys can take place. **Note:** Recording activities with camera or video equipment is possible. Pictures can be a great educational and promotional aid for the rest of staff and for other organizations.

### Phase III - Staff Education

One person in each department is clear on definitions, waste issues and the program mission. Part of this person's job is to serve as the department's contact, be a non-threatening sounding board, encourage brainstorming, provide information and identify how ideas are to be gathered.

Next, a department staff meeting takes place. This meeting can often be accomplished as a part of a regular staff meeting. Sometimes, however, employers furnish lunch at a special meeting and the presentation takes place then. Depending on the size of the organization, a person from senior management may be present. For each department, the team member presents:

- Photographs taken during the team tour.
- Information and comments from county solid waste personnel.
- Information and comments on the department's and the organization's waste.
- Review of mission statement.
- Definition and examples of source reduction and how it differs from recycling.
- Program outline, including management's plan for recognizing contributions from personnel.

Independent of how the communication takes place, after outlining the program, one central point needs to be conveyed:

**The organization's employees are most knowledgeable about ways that waste can be reduced or even eliminated at the organization, and their ideas are essential.**

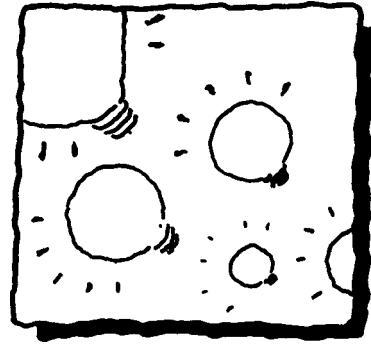

## 5. Brainstorm

**Ideas from the team** - Since emphasis is especially placed on educating the reduction team, good ideas to reduce waste often come from these people. Group brainstorming sessions involving the team are often very productive. All ideas are written down for later evaluation.

**Ideas from the staff** - The program's structure must make it easy for ideas to flow from as many people as possible. People who use products generate waste. These people are in the best position to generate ideas to reduce this waste. Management can assist by making it safe for employees to make suggestions without fear of criticism. All sincere ideas in brainstorming are good. Even though an idea may appear unworkable at first, it may lead to another more workable idea.

It is important to emphasize that this portion of the program has only questions, not answers. "Would it work if we reused our overlays?" is a question. **If people give their thumbs up or thumbs down "answers" to ideas too soon, the program will be harmed before ideas have a chance to evolve.** Judgment of ideas at this stage makes positions harden and curtails the flow of ideas. Don't let it happen to your program.

One method that works well to gather ideas from personnel is use of a conveniently located suggestion box. If a suggestion box is used, encourage people to sign their suggestions so that credit can be given. (Requiring identification also minimizes the temptation to make frivolous suggestions.)

Use of a circulation memo is another method to gather ideas. Individuals add their ideas to the memo, sometimes building on ideas already listed.

If the facility is small, suggestions can be made directly to the reduction team members.

To help people generate ideas as they consider the products they use, it is very helpful to suggest that they ask themselves the questions listed under the sample mission statement in Step # 1. If the preceding steps have taken place, many ideas will flow.

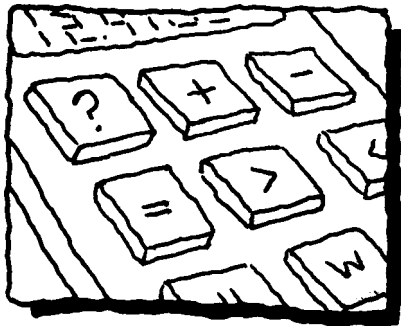

## 6. Evaluate

During this step, answers begin. Some of the ideas suggested will be simple to assess; others may require an engineer. However, all ideas will have two things in common — each idea is designed to affect waste, and thereby costs. Here are some answers to commonly asked questions.

### How are the suggestions prioritized for research?

Prioritizing questions helps organize efforts. Give priority to those ideas that are likely to: (1) result in significant waste prevention; (2) result in significant cost savings; (3) be highly visible to aid promotional efforts.

It is important to determine if suggestions to reduce waste result in an increase in the toxicity of waste. Solid waste reduction must not increase toxicity of the organization's waste. Similarly, determine if reduction suggestions to help one area cause unacceptable waste for another. For example, switching to reusable cloth rags from single-use paper towels used to clean up oil spills may decrease solid waste. However, if the laundry cannot properly process oily rags, the change is not advised.

### How much time passes before results are measurable?

This often depends on how much cooperation exists between management, the reduction team and the purchasing department. Much of the data required for assessment must come from the purchasing department staff. These people have resources to identify many alternative products. For a program to function, it must be clear that information is gathered to aid the purchasing department in its decisions.

Likewise, maintenance department staff need to be included as ideas evolve. Without goodwill even the best ideas will not succeed. With cooperative rather than competitive attitudes in place, product evaluations proceed smoothly. Senior management demonstrates support of the program when it makes sure these potential barriers are addressed.

With cooperation in place, measurable results are normally available within six months. These results can be used to motivate further change. Some program evaluation can also take place after this period of time. Barriers to the program can be addressed. Progress in implementing suggestions can be assessed. Reports on the success of product or behavior changes already implemented are made. Adjustments then take place.

### Can you actually measure waste and costs?

Sometimes the prospect of measuring waste and costs is intimidating, and this potential problem should be dealt with. Assure people that a pocket calculator and basic math are usually adequate for the job. Engineers may already be on staff at the types of facilities that have complex waste issues. For normal applications, regular staff does quite well. Commonly used measurement conversions can be found in Appendix A.

### How is waste evaluated?

- ▼ Every product that comes into the facility has a weight and a volume. After that product is used for its purpose, a specific residual weight and volume of waste must be managed as it leaves the facility.
- ▼ The change to another product, or a change of procedure using the original product, will also result in measurable changes in waste.
- ▼ Any two products or procedures can be compared. Though they fulfill the same function, the amount of waste produced by different products or procedures can vary substantially.

- ▼ These different weights and volumes of waste can be readily measured.

### How are costs evaluated?

Purchasing records give the quantity and cost of any product. These records establish the purchase cost and number used over a period of time.

The cost of alternative products is established by obtaining price information from distributors. However, the alternative product may have a different life span from the current product.

There are two main ways to establish life span of the alternative product.

1. Examine the warranty. Warranties give the minimum life span of the product, guaranteed by the manufacturer.
2. Evaluate information supplied by other organizations using the product, by in-house staff that has experience with such products and by consumer or trade journals that evaluate such products.

This product evaluation procedure is not new. Most purchasing officers are accustomed to evaluating the functional life versus the warranted life of different products. Once functional life is evaluated, costs over time for use of the alternative product can be determined.

**Note:** Experience shows that one of the best sources for product life information comes from those who have purchased and are using the product. Distributors are usually quite willing to give a list of other firms using their products. Other users have little vested interest in your purchasing decision and are usually helpful with product evaluations.

## Other factors

Other factors to consider are energy, water, disposal and labor costs as well as toxicity, safety and training changes. These factors will be dealt with briefly here. A more comprehensive discussion can be found in the “Source Reduction Purchasing Guidelines” section of this manual (page 40).

- ▼ Energy requirements of different products can result in measurable cost changes for the organization. Energy for lighting, heating water and running appliances can vary between products.
- ▼ Water usage may also change with different procedures or products. Sewage fees are usually derived from the number of gallons of water used by a facility and should be included with water use costs.
- ▼ Disposal costs often change with product or procedural changes. However, most facilities pay for refuse removal by volume and not by weight. If the fee is based on volume, existing dumpster volume requirements may not change enough by one action alone to allow for a decrease in contracted hauling. Cost saving for solid waste disposal often becomes measurable only after several source reduction actions are in place and contracted hauling volume can be decreased. For this reason, cost savings for disposal are not included as a cost benefit for an individual action unless it is shown that the action by itself results in a decrease in contracted hauling volume. If the organization’s fees are weight-based, savings come with each decrease in waste.
- ▼ Toxicity reduction will show a disposal cost savings if the change decreases waste handled as “hazardous waste.” Disposal of

hazardous waste is usually paid for by the gallon or pound. Each gallon or pound reduction results in a cost savings.

- ▼ Labor costs may also change with product or procedure changes and these should be reported. Unless the labor change is so significant that it results in the addition or subtraction of staff, there is no actual cost change. Staff work adjustments are common, and it is potentially misleading to indicate that there is dollar amount of “labor cost savings” for a product change if there are in fact no changes in the total hours worked by staff.
- ▼ Safety and training are two other factors that come into play with product or procedure changes. For safety, evaluators must know if the alternative product is at least as safe as the old one. For training, evaluators assess how much, if any, additional staff training is required to implement the reduction action. The distributor, other organizations who use the product and trade journals are excellent sources of information.



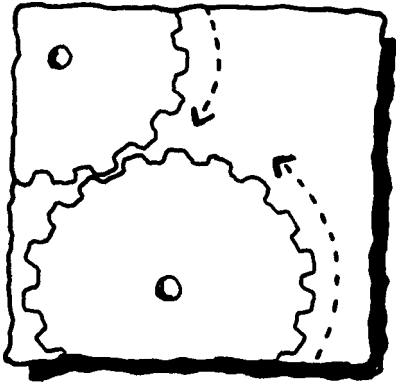

## 7. Implement

Researching ideas will show that if some of them are implemented, a reduction in waste will result. Many will also provide cost savings. Some actions will be able to be undertaken immediately. Use these ideas to add momentum to your program. This helps win support for more complex ideas that must be phased in over a period of time.

After a given action has been in place for a designated period of time, the facilitator asks for comments, positive and negative. All actions are written up in such a way that facts about the action can be conveyed to senior management. In this assessment, waste, costs and barriers to implementation are addressed. Barriers may be the result of complex issues involving distributors and manufacturers. With communication, even these barriers can be addressed. A barrier may be something as simple as, "Closed minds keep dumpsters open." Prompt follow-up on barriers is important. "Open minds can close them."

- Take "before and after" slides or photographs for promotion.

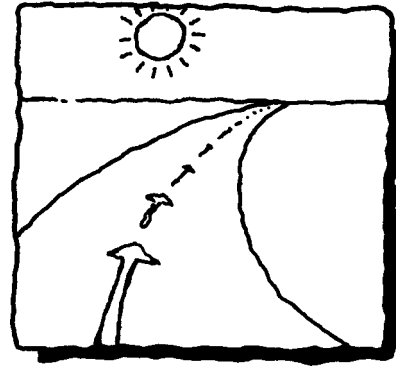

## 8. Continue

Effective support from upper management is essential to an ongoing program.

In addition to the commitments made in Step #1, these actions are also effective.

- ▼ Route relevant articles or fact sheets in Appendix E of this manual to employees periodically. This keeps program awareness high.
- ▼ Make sure the personnel department has training materials ready for new employees. Valuable new ideas can come from new people.
- ▼ City, county and state waste management agencies encourage promotion of source reduction. They may be willing to help write up your project as a case study, perhaps complete with slides and text. This presentation can be used by your organization or others to promote source reduction and your organization's program.
- ▼ Remind staff of the suggestion box periodically.
- ▼ Furnish employees with reusable beverage cups embossed with a brief message about the program.

- ▼ Provide speakers for community meetings, other organizations, business associations and waste management conventions.
- ▼ The media are also interested in sound environmental management. Reporters often seek these kinds of interviews.
- ▼ Make sure that the structure for recognizing additional source reduction activities remains in place. If this structure is not in place, ideas may be implemented without note and enthusiasm fades. Effective programs are self-perpetuating to the degree that management supports and promotes them.
- ▼ Make sure that all the ideas implemented are promoted to the entire staff.

Everyone has a part to play in reducing an organization's waste because everyone in the organization plays a part in creating waste. A waste prevention program is something that can foster communication and team-building. It has the potential to unite people from different departments in a common goal.



Rita Meyer of Burlington Northern Railroad says,

“As a result of our program, an employee noticed that we threw out boxes in one department and purchased boxes in another. Now we reuse the boxes, and we reduced waste for the departments by 20 percent. Now, 26 locations are reducing waste the same way.”

Employees share good ideas if they are given support to advance them.

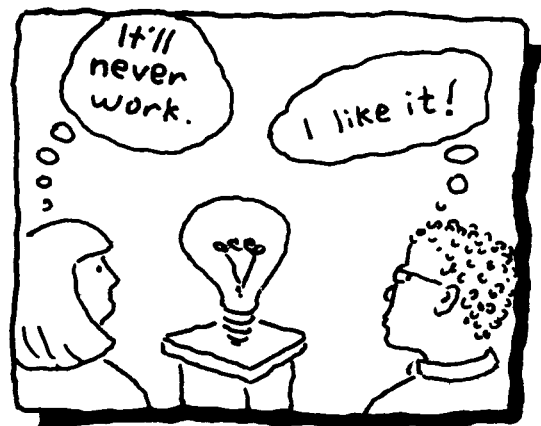



The following chapter explains how waste volume, weight and cost changes are measured when comparing one product to another product.

It is written for the people who do these measurements as a part of their program.

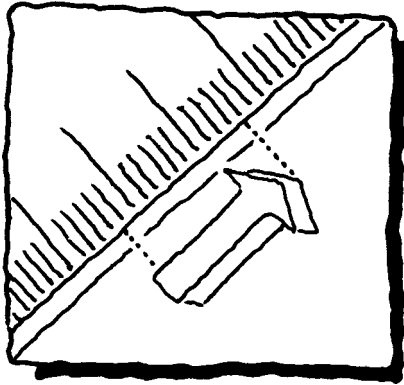

# Measurement

## of source reduction

Measuring the success of source reduction helps validate its effectiveness as a waste management tool. But, the question “How do you measure something that isn’t there?” can be an obstacle to source reduction. In truth, there is always something to measure, even if there is less of it.

Source reduction is measurable. Although many issues need to be addressed, measurement is predominantly an economic rather than a technical problem. If people and equipment are available to measure waste, changes due to source reduction can be documented. Some possible measurement methods include: **product-specific** measurement, **facility-specific** measurement and **community- or county-specific** measurement. This chapter will discuss product- and facility-specific measurement.

## Product-specific measurement

OEA case studies show that reduction is measurable on a product-by-product basis. Volume, weight and cost changes associated with each product or behavior change can be accurately determined. The process is not complicated. Most calculations are easily accomplished with good record-keeping and a pocket calculator.

### Basic information needed for product-specific evaluation

Different products used to fulfill the same need can be compared. The information below is used to compare wastes and costs for these products and is simplified to the following components.

Product A	Product B
Volume of one discarded product	Volume of one discarded product
Weight of one discarded product	Weight of one discarded product
Cost of one product	Cost of one product
Number used/year	Number used/year
Volume, weight and cost/year	Volume, weight and cost/year

An example from an actual case study follows. Many factors can be included in a measurement process. These measurements can be particularly detailed with laboratory-like procedures. In typical facility settings, however, the goal is to determine values to guide purchasing decisions only, and not to quantify absolutely all details of waste.

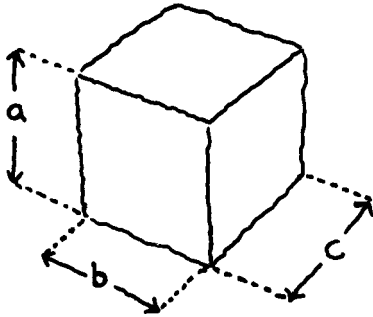

## Waste volume

Every waste product that leaves a facility has a measurable volume. The waste produced through the use of any two products designed to do the same job can be compared.

**Example:** Itasca Medical Center considered the possibility of changing from single-use cafeteria plates to reusable plates. To learn the feasibility of the change, the reduction team asked certain questions.

### What is the annual disposal volume of the single-use plate in current use?

When cafeteria customers finished with their plates, they threw them into a lined garbage can. The full bag was removed from the can and thrown into a dumpster, uncompacted.

To simulate actual disposal volume, 25 plates were thrown into a large box. The box was shaken to aid settling and the volume the plates occupied in the box was measured.

Length x Height x Width equaled 1,760 cubic inches for 25 plates.

With 500 plates in a case and a known disposal volume for 25 plates, the disposal volume of a case of plates was calculated.  $500/\text{case} \div 25 = 20$ . Twenty times the disposal volume of 25 plates (1,760 cu in) = 35,200 cu in; the disposal volume for one case of single-use plates (not counting the shipping container).

$$35,200 \text{ cu in} \times 64 \text{ cases used/yr} = 2,252,800 \text{ cu in/yr}$$

Disposal volume for use of the single-use plates was established as 2,252,800 cu in/year.

$$500 \text{ plates/case} \times 64 \text{ cases/yr} = 32,000 \text{ single-use plates/yr (or 88 plates/day.)}$$

### What is the annual disposal volume of the alternative product?

The hospital chose to evaluate a reusable plate of the same size. It measured 8.5 inches in diameter x .375 inches in thickness. Volume was determined by multiplying  $\pi$  times the radius squared times height, or  $v = \pi r^2 \times h$ ;

$$3.14 \times (4.25")^2 \times .375" = 21.26 \text{ cu"} \text{ each}$$

The actual volume of one plate was used as the disposal volume because these plates were thrown away one at a time and only if broken. Plates too worn for hospital use are kept until a number accumulate and are given to Goodwill for reuse.

### How many reusable plates are needed to replace the disposable ones?

The Dietary Department ordered 72 reusable plates for the cafeteria

$$21.26 \text{ cu inches each} \times 72 \text{ needed} = 1,531 \text{ cu inches}$$

### How long will the reusable plate last?

In order to determine amounts of waste and cost associated with the use of reusable plates, the life span of the plates must be known. After talking to the manufacture and staff who had experience using reusable plates of this type, a conservative life span of three years was assigned. (Approximately 1,000 uses per plate.)

$$1,531 \text{ cu in} \div 3 \text{ yr life span} = 510 \text{ cu in of waste/yr}$$

The average solid waste volume/year for reusable plates is established.

**Note:** These plates are not disposed of until after three years of service at which time they are actually donated for reuse.

### What is the difference in waste volume between the two?

$$2,252,800 \text{ cu in for single use} - 510 \text{ cu in for reusable} = 2,252,290 \text{ cu inch difference/year}$$

**Note:** Some solid waste is generated by the soap container from which soap is drawn to wash the reusable dishes. Similarly, the trash bags used to haul the single-use plates to the dumpster result in additional waste, as do the shipping containers for all the products. These wastes were not added into this example because the amounts were not significant enough to affect the purchasing decision for the

hospital. However, these peripheral wastes could be quantified if needed. Significant factors like water, energy and labor use are discussed later in this example.

### What percentage reduction in waste volume would this change make?

Percentage reduction is an important figure and it is easy to calculate. People in another organization can use it to estimate potential volume reduction after they establish a figure for use of their own single-use plates.

$$\text{Percent} = (x - y) \div x$$

$$\text{Percent} = (2,252,800 \text{ cu in} - 510 \text{ cu in}) \div 2,252,800 \text{ cu in} = 99.9\% \text{ volume reduction}$$

Another organization can potentially decrease its solid waste due to single-use plates by approximately 99 percent if it changes to reusable plates.

### How are cubic yards calculated?

Waste is typically billed in cubic yards. There are 56,656 cubic inches in one cubic yard.

$$2,252,290 \text{ cu in} \div 56,656 \text{ cu in} = 39.8 \text{ cu yd volume reduction/yr}$$

### What if a waste compactor is used?

To decrease volume-based hauling fees, some organizations are using trash compactors. In this case, use the compacted volume measurement. Haulers are aware of this issue and often assign weight limits to cans and dumpsters. Increased use of compactors is increasing haulers' motivation to change to weight-based fees.

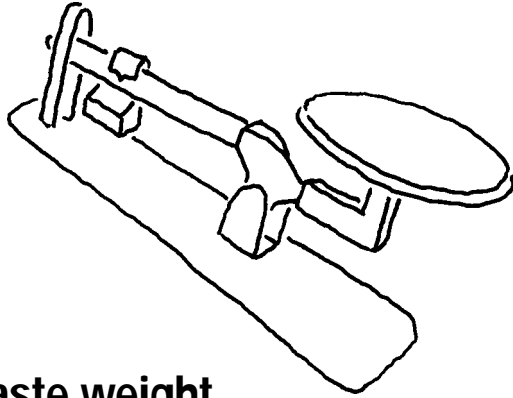

## Waste weight

Every waste product that leaves a facility has a measurable weight. The weight of waste produced through the use of any two products designed to do the same job can be compared.

### What is the annual disposal weight of the single-use plate in current use?

The single-use plates weigh 20 lbs. for a case of 500. Sixty-four cases are used each year. Twenty lbs. x 64 = 1,280 lbs/yr. (If shipping packaging is to be a part of the waste, the box is included as weight. If not, weigh an empty shipping container and subtract it from the weight of a full box.)

There are some products in which the shipping weight does not reflect disposal weight. For example, tires lose weight as they are used. Single-use diapers and other absorbent products gain weight.

### What is the disposal weight of the alternative product?

A reusable plate weighs 5.625 oz. 72 are needed and they have a 3-yr life. 5.625 oz x 72 ÷ 3 yr life = 135 oz/yr

$$135 \text{ oz/yr} \div 16 \text{ oz/lb} = 8.4 \text{ lbs/yr}$$

### What is the difference in waste weight between the two?

$$1,280 \text{ lbs} - 8.4 \text{ lbs} = 1,272 \text{ lbs/yr reduction}$$

### What percentage reduction in waste weight is this?

$$(1,280 \text{ lbs} - 8.4 \text{ lbs}) \div 1,280 \text{ lbs} = 99\% \text{ weight reduction}$$

---

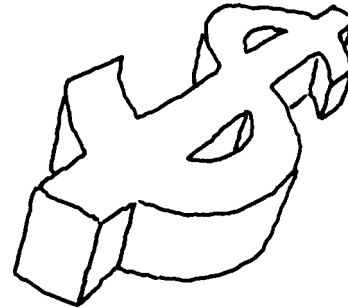

## Cost

Cost for the use and disposal of any product can be determined. The cost of using any two products designed to do the same job can be compared.

### What is the cost of the single-use plate?

$$\text{Purchase cost of 64 cases at } \$36/\text{case} = \$2,304/\text{year}$$

Additional costs: The following factors are recognized but not included in hard costs because of the indicated reasons.

- ▼ Approximately 700 trash can liners/yr are used to handle single-use plate waste. For this case, liner cost and liner waste was not significant enough to be a part of the purchasing decision for the hospital.

▼ Labor:

Labor required to order, stock, deliver and dispose of more than 32,000 single-use plates was estimated by assigning time required to do specific tasks. By multiplying time by the employees' wages and benefits, labor costs are calculated. However, unless implementation of an action actually results in a change in staff hours worked for a department or organization as a whole, these changes do not change actual dollars paid out for labor.

Implementing a given source reduction action rarely results in the elimination of a staff position, though implementing several actions may. In the change from single-use to reusable plates, labor decreased for purchasing and maintenance departments but increased for the dietary department. The change was incorporated by existing staff. Even if total wages paid by an organization does not change, tracking labor requirements for the use of different products is useful so that workload changes for different departments can be monitored.

▼ Hauling waste costs: Volume-based fee

By knowing the number of cubic yards of waste that are contracted for removal, a cost for each cubic yard can be calculated. For example: \$260 to empty a 15-cubic-yard dumpster = \$17.33 per cu yard. An annual reduction of 40 cubic yards in waste can mean 40 yds x \$17.33 /yd = \$693/yr savings. However, this figure does not translate into real dollars unless an actual reduction in hauling service is made. Most organizations have scheduled pick-ups that take place whether dumpsters are full or not. Several source reduction actions taken

together usually create an opportunity to decrease contracted hauling service.

▼ Hauling waste costs: Weight-based fee

Because of the increasing cost of managing waste, more and more refuse hauling trucks are equipped with scales. Billing is determined by actual use, as is the case with other utility services such as electricity, natural gas or water. By knowing the charge for each pound of waste, disposal cost savings are readily determined. The number of pounds reduced times the cost per pound = cost savings.

### What is the cost for using the reusable plate?

Purchase cost for 72 plates @ \$2.08 ea = \$150, ÷ 3 yr life = an average of \$50/yr

Additional costs: The reusable plates had certain hard costs that were measurable. Washing the plates used water, electricity and soap. The dietary department was aware of the costs associated with dishwashing.

Washing cost: 14 plates fit on each rack; 2.5 gallons of water is used /rack; 1/15¢ of electricity is used /rack; 3.5¢ of soap is used / rack.

32,000 single-use plates were used/yr, ÷ 14 plates/rack = 2,286 racks/yr.

**Water:** 2,286 racks/yr x 2.5 gallons/rack = 5,713 gallons/yr; water costs \$1.70 for 1000 gallons and sewer cost \$0.77 for 1,000 gallons, for a total of \$2.47 for 1,000 gallons. 5,713 gal used ÷ 1,000 gal x \$2.47 = \$14.11 /yr

**Electricity:**  $2,285 \text{ racks/yr} \times 1/15\text{¢}$  (or  $.066\text{¢}$ ) used per rack  $\div 100\text{¢}/\$ = \$1.52$  /yr

**Soap:**  $2,285 \text{ racks} \times 3.5\text{¢}$  (or  $\$0.035$ ) used per rack =  $\$79.97$  /yr

**Total /yr:**  $\$50$  purchase cost +  $\$14$  water +  $\$1.50$  electricity +  $\$80$  soap =  $\$146$  /year

**Cost of dishwasher:** Independent of this action, hospital dishwashers are needed and are in relatively constant use. Equipment cost can be calculated by determining the number of cycles the dishwasher is projected to run before needing replacement. Manufacturers and service representatives can help determine this. By knowing the cost of the dishwasher and the number of cycles it is expected to run, a cost per cycle can be estimated. In this case, increased use of the equipment was not considered substantial enough to be significant so this was not calculated.

**Labor:** Existing staff accomplished this change. There were no labor cost changes for the hospital.

### **What is the difference in cost between the two?**

Cost of single-use  $\$2,304$  - Cost of reusable  $\$146 =$   
 $\$2,158$  savings /yr

### **What is the percentage decrease in cost?**

$\$2,304 - \$146 \div \$2,304 = 94\%$  cost savings

It is important to note that these cost savings occur every year as long as the costs of the products stay consistent. Savings from source reduction continue into the future, and the money can be allotted to other needs.

The hospital also reduces waste by having cafeteria customers pay by the ounce for the salad they serve themselves. This cuts down on food waste. When single-use plates were readily available, they were sometimes grabbed for other purposes. Now that only reusable plates are available, inappropriate use is down. This points out an issue: Single-use products are often used in larger quantities than necessary whereas reusable products are usually not. For example: People are often observed grabbing more single-use towels than needed for the job, or making single-use plates more rigid by doubling them. The bottom plate is thrown out with the upper one.



## Product-specific evaluation: Conclusion

	PRODUCT A	PRODUCT B
Volume	2,252,800 cu inches/yr	510 cu inches/yr
Weight	1,280 lbs/yr	8.4 lbs/yr
Number used	32,000 in 1 year	72 in 3 years
Cost	\$2,304 /year	\$146 /year

Salad plates are needed by the cafeteria. A change from single-use to reusable cafeteria plates results in:

- ▼ Waste volume reduction of 40 cubic yards/year, a 99% reduction.
- ▼ Waste weight reduction of 1,272 pounds/year, a 99% reduction.
- ▼ Cost savings of \$2,158/year, a 93% reduction.

### Payback Period:

When compared to the cost of an old way of doing business, how long does it take for the cost of a new way of doing business to pay off?

- ▼ It costs \$2,304 a year to purchase the single-use plates.
- ▼ It costs \$150 for the initial purchase of the reusable plates.
- ▼ It costs \$95 a year to use the reusable plates, (energy, water and soap) for a total first year cost of \$245. The

change was implemented with existing staff and equipment.

- ▼ By dividing the \$245 cost for the reusable plates by the \$2,304 yearly cost to use the single-use plates, the length of time required for payback is determined;  $\$245/\text{yr}$  for purchase and use of reusables  $\div$   $\$2,304/\text{year}$  for purchase of single-use = 0.106 year.  $0.106 \text{ yr} \times 365 \text{ days/year} = 39 \text{ days}$  for payback.
- ▼ After 39 days the organization will save:  $\$2,304 \text{ a year for single-use} - \$95 \text{ a year for reusables} = \$2,209 \text{ a year for the remainder of life of the reusables.}$

## Other issues:

### How does shipping volume relate to disposal volume?

The shipping volume of a product is often different from its disposal volume. It is interesting to determine this difference. This is done by establishing both the shipping and the disposal volume of a product. For example:

To establish shipping volume, a factory-packed case of 500 plates was measured. The length times height times width equaled 3,316 cubic inches, and purchasing records showed that 64 cases were used each year.

$64 \text{ cases/yr} \times 3,316 \text{ cu inches/case} = 212,224 \text{ cu inches/year}$  for shipping volume

The disposal volume of 64 cases of plates is 2,252,290 cu inches (see text).

To calculate the ratio of disposal to shipping volume divide the disposal volume, 2,252,800 cu inches, by the shipping volume, 212,224 cu inches.

Disposal volume is 10.6 times greater than shipping volume.

### What if the products being measured are of irregular shape?

If products are of irregular shape, water displacement measurement is effective. Place the product in a thin plastic bag and submerge it in a volume-calibrated water-filled cylinder. The water displaced represents the volume of the product.

$\text{volume} = \pi(3.14) \times \text{cylinder radius}^2 \times \text{water height change}$

or you can weigh the displaced water, 1 gram = .061 cubic inch

## Conclusions about product-specific measurement

There are some limitations to an organization's product-specific measurement of source reduction.

- ▼ It is limited to the waste produced during use and disposal of those products only. It does not take into account the waste produced through the gathering of raw materials and manufacture of those materials into products.
- ▼ It does not indicate whether waste is increasing or decreasing for the community as a whole. If enough case studies are compiled for different waste generators, however, it may be possible to estimate the effect on the whole community's waste.

There are several strengths to product-specific measurement of source reduction.

- ▼ The data needed is usually available within the organization.
- ▼ Measurement of waste weight and volume, as well as cost changes, is practical.
- ▼ Since cost savings can be calculated before actual product changes are made, expenditures for an organization's source reduction program can be justified.
- ▼ Because products are compared to other products, calculations of baseline waste generation rates for the organization as a whole are not needed.
- ▼ Because alternative products are compared to the existing quantities of products used within the organization, the comparison is independent of external factors such as economic or population changes.



- ▼ Comparisons of the products' toxicity are possible. This assures that a decrease in waste volume or weight does not increase toxicity of the waste.
- ▼ Comparisons can take place in any industrial, commercial, institutional or consumer setting.
- ▼ Cross-media impacts, such as changes from solid to liquid waste can be taken into account.
- ▼ It proves that source reduction works without expending funds to measure progress on a regional basis.
- ▼ It empowers workers. Decisions to generate waste happen one at a time, product by product. This measurement method shows the impact of those individual decisions.

Commonly used measurement conversions are listed in Appendix A.

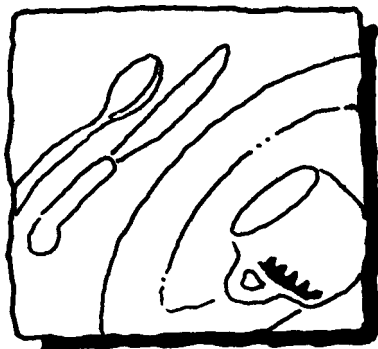
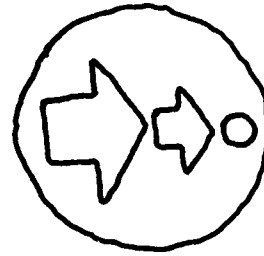

The following chapter gives guidelines to measure results of source reduction for an entire facility.

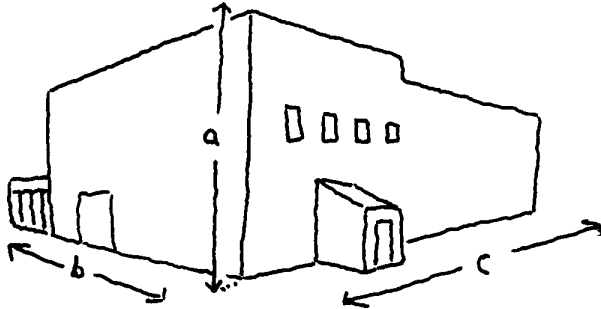

# Facility-specific measurement

Progress in source reduction is measurable on a facility-wide basis. This measurement is possible when all of the waste leaving the facility is weighed or measured for volume.

**Weight-based measurement:** There must be the means to weigh the waste leaving the facility. This is most convenient when the waste hauler has scales on the hauling truck. All solid waste, including recyclables, is weighed over a period of time to establish a base generation rate. After a comprehensive source reduction program is implemented, weighing takes place again, over time. The drop in weight of waste may be due to source reduction.

**Volume-based:** Measurements take place over time. The longer the time period, the more dependable the figure. Before each dumpster or recycling container is emptied by the hauler, the volume of waste is measured. Yardsticks or tape measures can work well to

measure dumpster waste volume. Liquid waste is measured by the gallon. After a comprehensive source reduction program is in place and recommendations are implemented, measurement takes place again. The drop in volume of waste may be due to source reduction.

## How can “may” be changed to “is” due to source reduction?

It is important to realize that factors other than products and behavior influence waste generation. The number of people in the organization, the type of projects under way and rate of production also influence waste generation.

**Number of people:** The number of people in an organization can affect amounts of waste. To isolate this influence on waste generation, a “pounds of waste per person” calculation is made.

This is accomplished by taking an average of the number of people that were in the facility while the initial waste measurement was done. If the facility had conferences attended by people from outside of the organization or many employees absent, make sure this information is taken into account. Divide the average quantity of waste per day by the average number of people per day to get the average quantity of waste per person per day.

Contrasting “before and after” data for solid and recycled waste is straightforward because it is measured directly. Changes occurring with liquid waste must also be quantified. Waste water is most simply tracked by recording the number of gallons of water used by reading water utility billing statements. If the facility is served by a private well, a meter must be used. Changes in the purchase and use of other liquids, cleaners for example, should be noted. Quantities of hazardous waste

are monitored. In addition, changes in energy consumption are tracked. After base generation rates for all of these waste media are established, progress can be measured. For some organizations this will be fairly simple, and for others it will be more complex. If people are assigned the job the data is available in either case.

It's possible that some organizations may be able to show decreases in solid waste generation by grinding waste and flushing it down the sanitary sewer. Similarly, burning waste reduces its volume but transfers waste into the atmosphere. Simply transferring waste from one medium to another is not source reduction.

After a program is in place and actions are implemented, repeat the measurement. The difference in the figures will give the change in the waste produced per person per day for solid, recycled and liquid waste.

**Types of projects:** Some projects produce more waste than others. Make note of unusual activities. Remodeling or production rate changes, including the number of printed reports, can make significant changes in waste generation that may overshadow results.

**Rate of production:** How rapidly products are produced affects waste generation. Production schedules show this information. If the organization manufactures a product, the average quantity of waste per day divided by the average number of products produced per day = waste per product. By contrasting the amount of waste produced before and after the program, the organization should be able to note improvements in efficiency.

## Conclusions

There are some limitations in facility-specific measurement of source reduction.

- ▼ Changes in waste generation are measured for the facility as a whole. This measurement does not quantify individual actions taken to reduce waste.
- ▼ It does not include cost changes due to individual actions or the program.
- ▼ It does not measure changes in the toxicity of individual products but can measure parts per million (ppm) of any element at the point of discharge.
- ▼ Estimates must be made to establish which changes are due to source reduction and which changes to other factors.
- ▼ Unless waste water and energy consumption is monitored, solid waste may be reduced without understanding consequences to another medium. For example, a change from single-use to reusable rags will reduce solid waste but may increase waste water.
- ▼ It does not indicate whether waste is increasing or decreasing for the community as a whole. If enough case studies are compiled for different organizations, however, it may be possible to estimate community potential to reduce waste.
- ▼ It requires establishing a base generation rate in all of the organization's waste media against which changes are compared.

There are strengths in facility-specific measurement of source reduction.

- ▼ The data needed is available from within the organization.

- ▼ Weighing of waste is accomplished by a waste hauler or other individual. Staff time for measurement may be minimal.
- ▼ Measurement methods for waste weight and volume are practical and straightforward.
- ▼ To monitor cross-media impact, it is possible to monitor changes in amounts of sewered waste in addition to changes in amounts of solid waste.
- ▼ After allowance for internal population and production changes, the assessment is independent of external population or economic shifts.
- ▼ Because measurements are taken for all waste media, a valuable picture of wastes generated by the whole organization is obtained.

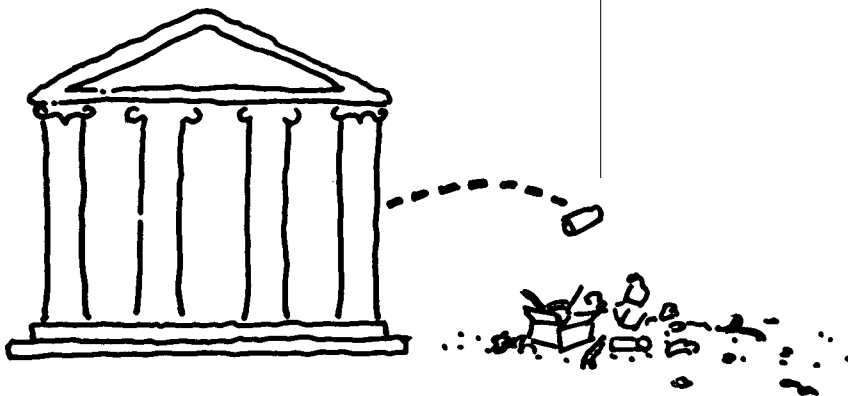

The following section gives guidelines to use when purchasing products that reduce waste.

It is written for people who make purchasing decisions as part of their source reduction program.

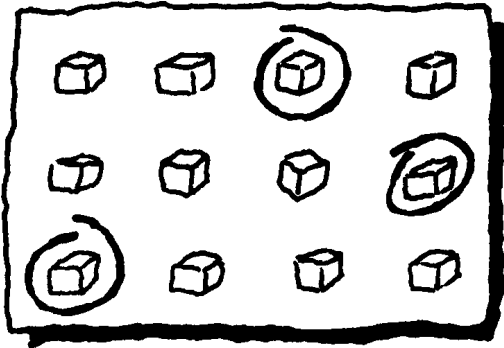

# Purchasing guidelines for source reduction

Two factors that influence a purchasing decision are quality and value. When source reduction is included in these traditional elements, the meanings of “quality” and “value” gain depth.

More than ever, reducing waste is an important factor to consider in the search for products. This section provides guidelines that can be used in this search. It has both objective and subjective elements. It is designed to identify choices that will reduce waste for manufacturers, (they consume products from other manufacturers) as well as end-use consumers. Reducing waste can improve quality and maintain value of the environment.

## What types of products reduce waste?

Use these source reduction cornerstones to evaluate products.

**Reduce** Products that accomplish the job with less material and less toxicity.

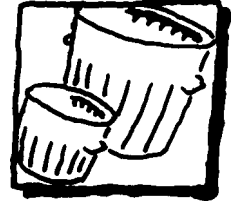

**Reuse** Products that can be reused rather than discarded after one use.

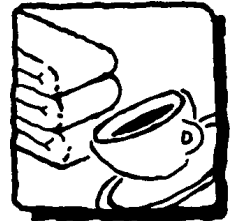

**Repair** Products that are refillable or repairable to give a longer useful life.

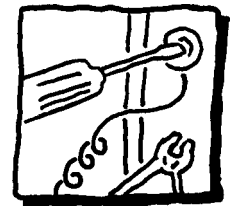

Increasingly, waste is a factor included in the bidding process. In general, the goal is to motivate manufacturers to take more responsibility for the waste created through:

- Shipping,**
  - Use and**
  - Disposal**
- of their products.

**? How can manufacturers be motivated to care about shipping, use and disposal of waste when these wastes traditionally don't affect their bottom lines?**

Make it clear in writing to your suppliers that your purchasing decisions include waste as a factor. This tells them that the waste you must handle does affect their sales.

# Shipping, use and disposal

The following suggestions are particularly helpful when integrated into the purchasing process.

## 1. Shipping: Apply source reduction cornerstones to shipping needs.

**Reduce:** Require manufacturers to state what they are willing to do to reduce the amount of material or toxicity of their shipping containers while maintaining protection of the product.

Examples to reduce material: Are shipping containers unnecessarily large or thick? If dividers are used, are they necessary? Are products individually wrapped? Can the products be sold in bulk? Can packaging ink or plastic be reduced?

Examples to reduce toxicity: Ask the manufacturer if less hazardous packing alternatives are available. Are plastic liners necessary? Are they glued to corrugated packaging?

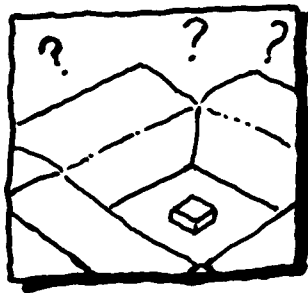

**Reuse:** Require the manufacturer to state the possibilities for using reusable shipping containers and packaging. Is backhauling of shipping materials possible, so that they can be reused by the manufacturer?

If backhauling is not possible, are the shipping materials reusable by others?

**Repair:** If shipping containers and packaging are reusable, are they also repairable? Shipping materials designed for one-time use are not manufactured to be repairable.

## 2. Use: Apply source reduction cornerstones to the selection of products.

**Reduce:** Write into the bidding request, "Preference will be given to products that create the least solid or hazardous waste while fulfilling the desired function." Products that use less material, or result in the use of less material, fulfill this need. For example, concentrates use smaller containers than dilute solutions. Efficient products create less waste.

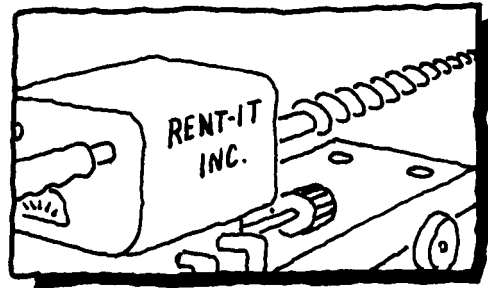

**Reuse:** Can the product be reused over and over? For example, durable products are more reusable than short-lived ones. Can the product be rented to others to offset the higher initial cost more quickly?

**Repair:** Is the product manufactured to be repairable, refillable or upgradable? If so, does the manufacturer repair and upgrade the product, or is repair done by independents? How accessible and cost-effective are parts? How many years are parts

guaranteed to be available? What is the product's warranty? Are extended warranties available for a reasonable price? Are quality, remanufactured products available for purchase rather than new ones?

**3. Disposal:** Apply source reduction cornerstones to the need for disposal.

**Reduce:** Upon disposal, is toxicity of the product a problem? If so, are less toxic alternatives available? Manufacturers supply Material Safety Data Sheets (MSDS) that can provide information on the toxicity of their products.

**Reuse:** After the product has reached the end of its useful life for the purchaser, can it be given or sold for reuse to others?

**Repair:** Will the manufacturer take the product back for remanufacture? If not, will other businesses remanufacture the product for reuse? If the whole product cannot be remanufactured, can parts of it be used to repair others?

### **When specific products are compared, how are they evaluated?**

As products are compared to each other the following list of questions helps clarify purchasing decisions. General factors that are commonly part of existing purchasing guidelines are identified first. Guidelines used as needed are identified next. Three final factors reflecting concern about waste are added.

The following section lists questions to ask when purchasing products that reduce waste

## **Purchasing guidelines checklist**

### **Commonly used factors**

- **Cost of product** The cost to purchase a product is at the core of many purchasing decisions. However, purchase cost does not include the cost to use and dispose of the product. These costs vary between products. Treat the cost of purchase as a base figure to which other costs are added.
- **Warranty** To calculate the cost of a product through its use, its life must be known. Two products of similar price but different useful lives can mean very different costs to the user. Warranties give the minimum life of a product as guaranteed by its manufacturer. If extended warranties are purchased, this cost is added to the cost of the product. The maximum amount of time a manufacturer is willing to extend its product's warranty is a good indicator of useful life.
- **Life of product** The life span of a product (how long the product can be used), is usually different from its warranted life (how long the product is guaranteed by the manufacturer). Purchase decisions are commonly based on life span. The life span is determined by gathering information from those who are familiar with the product. Maintenance people, manufacturers, distributors, the American National

Standards Institute and consumer publications are all resources for determining life span. Often, a distributor will furnish names of others who are using the product. These people are usually quite willing to tell others of their experience with the product.

- **Repairability** Is it cost-effective for the product to be repaired, refilled or remanufactured? Does the product have interchangeable parts with other models in use? Are remanufactured products available that can fill the same need as new ones?
- **Reusability** Can the product be reused over and over again? Does the product retain enough value so that it can be sold or given away for reuse? Can the product be rented to or from others? Can an agreement be formed so that its use and expense are shared with others?
- **Quantity needed each year** Each product will last for a given period of time. The different lives of different products result in different quantities needed each year. For example, if Product A lasts one day, 365 may be used each year. Similarly, if Product B lasts two years, half of the product is used each year.
- **Cost each year** The purchase cost of one product times the number needed in a year gives the cost for each year. For example, if Product A costs \$0.35 each and 365 are used each year, the purchase cost is \$128 each year. Similarly, if Product B costs \$80 and lasts 2 years, one-half of the

product is used each year resulting in an amortized purchase cost of \$40 each year.

### Factors used as needed

- **Toxicity** It is important that changes made to reduce solid waste do not increase the toxicity of waste generated by the organization. Does the product produce toxins through its use and disposal? Must it be treated as hazardous waste? Information on product toxicity is available in the Material Safety Data Sheet (MSDS), provided by law from the manufacturer.
- **Safety** Any time two products are compared, user safety should be addressed. One product may be more hazardous and consequently less safe to use than the other. The frequency with which items must be handled, transported, serviced and disposed can affect safety.
- **Labor** The use and disposal of different products often require different amounts of labor. To assess labor requirements, estimate time required to order, stock, service and dispose of comparative products. With known labor costs and time required for each activity, labor costs can be effectively estimated. Note: Labor costs do not actually change for a facility unless staff hours are either subtracted or added to payroll as a result of the action.
- **Other costs** Product efficiency can be compared. What are the electricity, gas, water or other needs for different products? Are rebates available? For example, use of reusable dishes requires energy, water and



soap (an additional product). The costs of these elements should be added to the cost of the product. Purchase of an energy- or water-efficient dishwasher may qualify for a rebate, affecting costs. Similarly, use of single-use dishes may require garbage bags (an additional product) not needed for the reusables. Sometimes the level of service provided by the supplier may affect costs. For example, in some cases they suppliers take responsibility for the disposal of their product.

### Added factors to assess waste

#### ■ **Weight of waste each year** (a waste factor)

The number of products needed each year times the disposal weight of one product gives the disposal weight generated through the use of that product for one year. For example, if Product A weighs .05 pound and 365 are used each year, then 18 pounds of waste are generated each year. If Product B weighs 20 pounds and one product is used every two years, then an average of 10 pounds of waste is generated each year.

**Note:** Some products – absorbent paper products for example – gain weight when used. Weighing a representative sample of discarded products is the best way to determine disposal weight.

? What about packaging waste? If packaging waste is to be considered as a part of the waste created through the use of a product, then the weight of packaging is added to the weight of the product. This is accomplished by weighing the shipping container.

#### ■ **Volume of waste each year** (a waste factor)

The number of products needed each year times the disposal volume of one product gives the disposal volume generated through the use of that product for one year. For example, if Product A has a disposal volume of 6.25 cubic inches and 365 are used each year, then 2,281 cubic inches of waste are generated through its use each year.

**Note:** Some products gain volume as they are used. For example, products efficiently or tightly packed in a shipping container take up more volume upon disposal. Disposal volume is usually greater than shipping volume. Measuring a representative sample of discarded products, whether they be routinely stuffed in a bag or compacted, is the best way to determine disposal volume.

? What about packaging waste? If packaging waste is to be considered as a part of the waste assessment, disposal volume of the shipping containers is added to the disposal volume of the products.

#### ■ **Disposal cost each year** (a waste factor)

What is the cost for disposal of the product?

**Volume-based fee:** Multiplying the yearly disposal volume of a product times the cost per cubic yard for hauling service gives the annual disposal cost for the product. **Note:** Actual hauling costs only change when contract service is reduced.

**Weight-based fee:** By multiplying the yearly disposal weight of a product times the cost per pound for hauling service, the annual disposal cost for the product is determined. Cost decreases more with each reduction action.

■ **Recyclability** Although many containers are locally recyclable, most products are not. In general, locally recyclable products should be preferred over non-recyclable ones. Containers are much more commonly recyclable than products. Some facilities pay for recyclable material pick-up while others do not. These factors affect costs and amounts of disposal waste.

■ **Recycled content** If consumers do not purchase products with recycled content, recycling will fail. Adding this statement, “Preference will be given to products containing post-consumer recycled content,” helps inform manufacturers of the need for recycled products.

? **What’s the best choice when a product contains recycled content but generates more solid waste than another product without recycled content?** Until evidence indicates otherwise, choose the product that creates less **disposal waste** for your organization. For example, ground coffee is available in steel cans or vacuum-sealed brick packs. The steel cans are recyclable, the multilayered brick packs are not. Yet, the brick packs represent an 85 percent reduction in waste weight compared to the can. Which should you choose?

If the cans are not recycled by your organization, use brick packs. If the cans are recycled, use cans. While this “disposal waste” assessment is a simple way to deal with the issue, collecting and remanufacturing the cans may actually result in more waste when entire life cycle of the product is taken into account.

Individual organizations rarely have the information available for this complex assessment. Unless it is available, limit focus to the disposal waste generated by the organization.

The chart on the following pages outlines the preceding factors and can be used as worksheet.



## Source Reduction Purchasing Guidelines Chart (Side A)

Factor	Product A	Product B
<b>Cost:</b> What is the purchase cost of each product? (Include price of extended warranty if planned.)	Cost:	Cost:
<b>Warranted life:</b> What is the warranted life of the product?	Warranted life:	Warranted life:
<b>Durability:</b> What is the estimated life of the product in your application? (This information may come from the manufacturer, maintenance records or consumer publications.) Is the product upgradable for a longer life?	Estimated life:  N/A      Yes Somewhat   No	Estimated life:  N/A      Yes Somewhat   No
<b>Repairability:</b> Is it cost-effective to have the product refilled, remanufactured or repaired? Does the product have parts that are interchangeable with other models currently in use?	N/A      Yes Somewhat   No  N/A      Yes Somewhat   No	N/A      Yes Somewhat   No  N/A      Yes Somewhat   No
<b>Quantity per year:</b> Based on expected product life, what is the number of items needed for one year?	Quantity per year:	Quantity per year:
<b>Cost per year:</b> Cost of one unit x the number needed per year. (Note: Number needed per year may be a fraction of a whole number when the longevity of the product is greater than one year. For example, if product life is four years, then 25% of product life is used in one year.)  * Figures from Side B	Cost per year of product only: Labor cost (*): Resource cost (*): Extra material cost (*): Disposal cost (*): Total cost:	Cost per year of product only: Labor cost (*): Resource cost (*): Extra material cost (*): Disposal cost (*): Total cost:
<b>Weight:</b> What is the disposal weight of the product, including packaging? (This gives weight for the use of one product. Note: Absorbent products often increase in weight after use.)	Weight:	Weight:
<b>Weight per year:</b> Quantity per year x weight for the use of one product.	Weight per year:	Weight per year:
<b>Volume:</b> What is the disposal volume of a case of the product (or one product), including packaging?	Volume:	Volume:
<b>Volume per year:</b> Number of cases or products per year x disposal volume of one case or product.	Volume per year:	Volume per year:

## Source Reduction Purchasing Guidelines Chart (Side B)

Factor	Product A	Product B
<p><b>Disposal costs per year:</b> What are the costs for disposal of the product? Cu. yds. or gallons of waste x cost for one = cost. Note: Not actualized unless service is reduced.) * Add to Side A, under Cost per year.</p>	Cost per year:	Cost per year:
<p><b>Toxicity:</b> What is the comparative toxicity of the product, in use and disposal?</p>	N/A Low Medium High	N/A Low Medium High
<p><b>Worker safety:</b> Including servicing and repair, what is the comparative worker safety involved in the use and disposal of the product? Rate the danger as low, medium or high.</p>	N/A Low Medium High	N/A Low Medium High
<p><b>Labor:</b> What is the comparative labor expense of using the product? Infrequent labor —Low Frequent labor —Medium Very frequent labor —High Not applicable —N/A (With known labor costs and time required for each activity, actual costs can be estimated. Note: Not actualized unless there are staff changes.) * Add to Side A, under Cost per year.</p>	Ordering: N/A Low Medium High Stocking: N/A Low Medium High Servicing: N/A Low Medium High Disposing: N/A Low Medium High	Ordering: N/A Low Medium High Stocking: N/A Low Medium High Servicing: N/A Low Medium High Disposing: N/A Low Medium High
<p><b>Other costs:</b> What is the comparative resource use required through the use of the product? Quantify where possible. Electricity Other fuels Water Additional materials *Add to Side A, under Cost per year.</p>	Electricity: N/A Low Medium High Other fuels: N/A Low Medium High Water: N/A Low Medium High Addn'l materials: N/A Low Medium High	Electricity: N/A Low Medium High Other fuels: N/A Low Medium High Water: N/A Low Medium High Addn'l materials: N/A Low Medium High
<p><b>Recyclability:</b> Is the product locally recyclable? Is its container locally recyclable? Does this affect costs?</p>	Yes Somewhat No Yes Somewhat No Yes Somewhat No	Yes Somewhat No Yes Somewhat No Yes Somewhat No
<p><b>Recycled content:</b> Does the product have post-consumer recycled content? If yes, what percent?</p>	Yes No _____%	Yes No _____%

On an annual basis, Product \_\_\_\_ appears to be cost-effective and reduce waste.

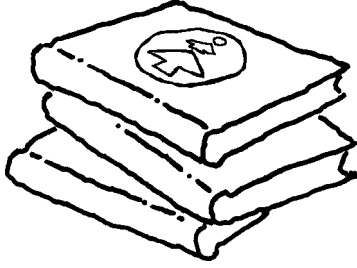

# Case Studies

The following case studies report the results of implementing source reduction programs at three organizations: a hospital, a county courthouse and a newspaper. These studies focus on solid waste reduction, although changes in hazardous and liquid waste are also identified.

The OEA gave assistance to focus source reduction activity and document results for the organizations, but the programs are self-perpetuating. The reduction teams continue without assistance from the OEA. As the organizations find new ways to reduce their waste, the OEA will update the case studies.

The goal of the case studies was to determine what changes reduce amounts of waste generated by the organizations, not to conduct full life-cycle analysis of the products.

The OEA has several criteria for prioritizing potential case studies.

- **So that the information will have broad applicability:** Case studies are done with organizations whose waste is similar to that of numerous other organizations. Organizations with several major waste streams are preferred over those with just one or two major waste streams. An exception to this is when one particular waste stream is significant to a region or community.

- **So that information can be readily distributed:** Case studies are done with organizations that are members of professional associations, preferably associations that have their own newsletters.
- **To identify which organizations are motivated to reduce waste:** Organizations are chosen from those that request assistance. This is accomplished by informing organizations about the availability of technical assistance to reduce waste and costs, write up and promote programs. Selection is made from the applicants. Working with organizations that request help is preferred because they are more likely to have the internal motivation necessary for a successful program. In addition, for programs to last, motivation to reduce waste must come from within the organization.

## Recycling versus Reduction

Though reduction programs were the only efforts quantified in the case studies, recycling programs were facilitated at the same time. Research showed that source reduction rarely affected recyclable material. Approximately 90 percent of the reduction activities dealt with products that were non-recyclable, indicating that the conflict between reduction and recycling may be overstated.

## Savings

Most of the cost savings came through use of more efficient products or behavior. Because these savings proved so significant, on a percentage basis, comparatively little savings came from reductions in waste hauling costs.

# Source Reduction

## A hospital case study

Facility:

**Itasca Medical Center**  
126 First Avenue SE  
Grand Rapids, Minnesota 55744

The Itasca Medical Center is a 108-bed community hospital with an attached 35-bed convalescent nursing care facility. The hospital staff made a commitment to source-reduce the hospital's waste as much as possible. Secondly, what they could not reduce they committed themselves to recycle.

The project demonstrates that source reduction is a viable waste management method for hospitals. Measurement of cost changes and waste prevented took place on a product-by-product basis. Product waste was measured through the hospital's use and disposal of a product and did not attempt to measure waste produced through the manufacturing process of the product. The hospital's goal was simple: Reduce the amount of solid waste generated by the facility.

As a result of reduction actions alone, the hospital personnel is preventing **245 cubic yards** and over **10,700 pounds** of waste. Not including the savings from avoided disposal fees, these

actions result in a **\$11,030** yearly cost savings for the hospital.

Reduction is defined as any activity that reduces waste at its source. The staff members examined their own waste stream and brainstormed ideas to accomplish reduction. As they looked at their waste stream, they asked themselves the following questions:

- ▼ Where can I **reduce** the amount or the toxicity of material used to accomplish any task?
- ▼ Are there existing or new products I can **reuse** over and over again?
- ▼ Are there existing or new products that are repairable, refillable or more durable to give a **longer useful life**?

These are the three pillars on which they based their efforts to reduce the amount of solid waste generated by their facility. The specific measures they identified are contained within this report.

This project was a team effort involving virtually all of the supervisors and staff at the hospital and had complete support of the director, David Triebes. Without their suggestions and implementation of the actions reported here, unnecessary waste would continue. Jim Thibodeau of purchasing and Judy Mager of dietary gave outstanding leadership for the project. Without this leadership the project would not have been possible. Technical support for the case study was provided by Kenneth Brown 612-296-3417, Minnesota Office of Environmental Assistance.



## Use reusable instead of single-use cafeteria salad plates

Although reusable plates are used to serve most food, the cafeteria served salads on single-use plates. Now salads are served on reusable dishes as well. As a further measure to reduce waste, cafeteria customers pay by the ounce for the salad they serve themselves, cutting down on food waste.

### Volume of waste avoided: 43 cu yd/yr: A 99% volume reduction

■ **Single-use:** 8" single-use plate; 55 cases/yr x 3,316 cu"/case = 182,380 cu" shipping volume. Actual disposal volume of 25 plates is 1,760 cu" for 25 plates.

6" single-use plate; 9 cases/yr x 2,100 cu"/case = 18,900 cu" shipping volume; Actual disposal volume of 32,000 plates was calculated to be  $32,000 \div 25 = 1,280 \times 1,760 \text{ cu}'' = 2,252,800 \text{ cu}''/\text{yr}$ , x 90% to allow for dumpster settling = 2,027,520 cu"/yr. Percent increase from shipping to disposal volume =  $2,027,520 - (182,380 + 18,900) \div 2,027,520 = 90\%$  increase.

● **Reusable:** measures 8.5" diameter x .375" thick.  $\pi r^2 h = v$ ;  $3.14 \times 4.24^2 \times .375'' = 21.26 \text{ cu}'' \text{ ea}$ ;  $21.26 \text{ cu}'' \times 72 \div 3 \text{ yr life} = 510 \text{ cu}''/\text{yr}$

Net:  $2,027,520 - 510 = 2,027,010 \text{ cu}'' \div 46,656 \text{ cu}''/\text{cu yd} = 43.4 \text{ cu yd/yr}$   
 $2,027,520 - 510 \div 2,027,520 = 99\%$  volume reduction

### Weight of waste avoided: 1,235 lbs/yr: 99% weight reduction /yr

■ **Single-use:** 8" single-use plate; 20 lbs/case of 500, 55 cases/yr = 1,100 lbs  
6" single-use plate; 15 lbs/case of 500, 9 cases/yr = 135 lbs; 1,235 total lbs/yr

● **Reusable:** plate weighs 5.625 oz x 72  $\div$  3 yr life = 135 oz/yr

Net:  $1,235 \text{ lbs} - (135 \text{ oz} \div 16 \text{ oz/lb}) = 1,226 \text{ lbs/yr reduction}$ ;  
 $1,226 \div 1,235 = 99\%$  weight reduction

### Cost savings, not including avoided disposal fees: \$2,126 /yr: 94% cost savings /yr

■ **Single-use:** 6" plate, \$275/yr + 9" plate, \$1,980/yr = \$2,255 /yr

● **Reusable:** 72 plates purchased @ \$2.08 ea = \$150,  $\div$  3 yr life = \$50 /yr

Washing cost: 14 plates /rack; 2.5 gallons of water is used /rack; 1/15¢ of electricity /rack; 3.5¢ of soap /rack. 32,000 single-use plates were used/yr,  $\div$  14 plates/rack = 2,285 racks/yr.

Water:  $2,285 \text{ racks} \times 2.5 \text{ gallons} = 5,713 \text{ gallons/yr} \times (\$2.47 \text{ per } 1000 \text{ gallons for water and sewer combined}) = \$14.11 / \text{yr}$

Electricity:  $2,285 \text{ racks} \times 1/15\text{¢} (.0066) = \$15 / \text{yr}$

Soap:  $2,285 \text{ racks} \times 3.5\text{¢} (.035) = \$79.97 / \text{yr}$

Net: Single-use \$2,255 - (Reusable \$50 + \$14 + \$15 + \$80) = \$2,126 savings /yr

• **Indirect costs:** Old reusable plates are given to Goodwill for reuse; no disposal cost. On large volume days, maintenance was called to empty cafeteria trash cans one to two extra times per week. With reusables, extra pick-ups have ceased. A reduction of 36 cu yd/yr x \$6.25/yd gives a theoretical savings of \$225 /yr. However, contracted hauling volume was not decreased due to this action alone.

There was a decrease in labor for purchasing and maintenance departments in managing and handling this waste. There was an increase in labor for dietary to handle the reusables. The existing staff integrated this action. There were no staff changes for the hospital as a whole.



## Reusable desert dishes replace single-use

Small ceramic dishes are now used instead of plastic, single-use desert cups. Nurses report that patients appreciate the change to the use of the more substantial ceramic dishes because they convey a more positive feeling than the thin plastic trays.

### Volume of waste avoided: 75 cu yd/yr: 99% volume reduction

■ **Single-use:** Two sizes were replaced. Tray one:  $138 \text{ /day} \times 365 \text{ days/yr} = 50,370 \text{ dishes/yr}$  with a shipping volume of  $80 \text{ cu}''$  versus  $1,430 \text{ cu}''$ , actual disposal volume for 50 trays. (A 94.4% volume increase).  $50,370 \text{ trays/yr} \div 50 = 1,007.4$ ,  $\times 1,430 \text{ cu}''$  for 50 trays,  $\times 90\%$  (dumpster settling allowance) =  $1,296,524 \text{ cu}''/\text{yr}$

Tray two:  $246 \text{ /day} \times 365 = 89,790 \text{ dishes/yr}$  with a shipping volume of  $65 \text{ cu}''$  versus  $1,375 \text{ cu}''$ , actual disposal volume for 50 trays. (A 95.3% volume increase).  $89,790 \text{ trays/yr} \div 50 = 1,795.8$ ,  $\times 1,375 \text{ cu}''$  for 50 trays,  $\times 90\%$  (dumpster settling allowance) =  $2,222,302 \text{ cu}''/\text{yr}$

$1,296,524 + 2,222,302 = 3,518,826 \text{ cu}''/\text{yr}$

● **Reusable:** 400 needed, measuring  $4'' \times 2.75'' \times 1.5'' = 16.5 \text{ cu}$  in each. Life is 3 years,  $400 \div 3 = 133.3 \text{ /yr}$ ,  $\times 16.5 \text{ cu}'' = 2,200 \text{ cu}''/\text{yr}$

Net:  $3,518,826 \text{ cu}'' - 2,200 \text{ cu}'' = 3,516,626 \text{ cu}''/\text{yr} \div 46,656 \text{ cu}''/\text{yd} = 75 \text{ cu yd/yr}$  volume reduction;  $3,516,626 \div 3,518,826 = 99\%$  reduction

### Weight of waste avoided: 1,230 lbs/yr: 96% weight reduction

■ **Single-use:** Tray one:  $6.1 \text{ oz}$  for 50;  $50,370 \text{ used /yr} \div 50 = 1,007.4$ ,  $\times 6.1 \text{ oz} = 6,145 \text{ oz/yr}$

Tray two:  $8 \text{ oz}$  for 50;  $89,790 \text{ used/yr} \div 50 = 1,795.8$ ,  $\times 8 \text{ oz} = 14,366 \text{ oz/yr}$

$6,146 + 14,366 = 20,512 \text{ oz/yr}$

● **Reusable:**  $6.26 \text{ oz}$  each  $\times 133.3 \text{ /yr} = 833 \text{ oz/yr}$

Net:  $20,512 - 833 = 19,679 \text{ oz/yr} \div 16 \text{ oz/lb} = 1,230 \text{ lbs/yr}$  weight reduction;  $19,679 \text{ oz/yr} \div 20,512 \text{ oz/yr} = 95.9\%$  weight reduction

### Cost savings, not including avoided disposal fees: \$904 /yr: 60% cost savings/yr

■ **Single-use:** Cost;  $\$64.40/\text{case} \times (8.4 + 15) \text{ cases} = \$1,507/\text{yr}$

● **Reusable:** Cost  $23.95$  a dozen; 400 needed,  $\div 12 = 34$  dozen,  $\times \$23.95 = \$814$ ;  $\div 3 \text{ yr/life} = \$271/\text{yr}$

Costs of water, sewer, electricity and soap:  $400 \text{ dishes washed /day} \div 21 \text{ dishes on a rack} = 19 \text{ racks run/day}$ .

Water and sewer for  $2.5 \text{ gallons/rack}$  is  $19 \times 2.5 \text{ gal} = 47.5 \text{ gal/day} \times 365 \text{ days/yr} = 17,338 \text{ gal/yr}$ ,  $\times \$2.47/1000 \text{ gal} = \$42.82/\text{yr}$

Electricity is  $.0066\text{¢} /\text{rack} \times 19 \text{ racks/day} \times 365 = \$45.77/\text{yr}$

Soap is  $3.5\text{¢} /\text{rack} \times 19 \text{ racks/day} \times 365 = \$243/\text{yr}$

Net:  $\$1,507 - (\$271 + \$43 + \$46 + \$243) = \$904 \text{ cost savings/yr}$ ;  $\$904 \div \$1,507 = 60\%$

**Indirect costs:** A reduction of  $62 \text{ cu yds}$  of waste /yr theoretically translates into  $62 \times \$6.25/\text{cu yd} = \$387 \text{ /yr}$ . However, contracted hauling volume was not decreased due to implementation of this measure alone. Labor for purchasing and maintenance decreased due to less management and handling of single-use dishes. Labor for dietary increased or due to washing of reusables. Implementation of this action was integrated by existing labor. The hospital as a whole did not experience an increase in labor cost.





## Change to rechargeable batteries

For minimal disruption of patients' sleep, nursing staff used "D" cell flashlights to check on patients during the night. This practice was appreciated by patients but resulted in large quantities of spent batteries. Rechargeable flashlights are now used. Purchased over four years ago, the original sample still performs very well.

### Volume of waste avoided: 1,272 batteries or .074 cu yd each year; 98% volume reduction

■ **Disposable:** "D" cell battery purchased dropped from 120 per month to 14 per month, a decrease of 106 batteries per month.

Net change in battery volume;  $106/\text{mo} \times 2.77 \text{ cu}"/\text{battery} \times 12 = 3,523 \text{ cu}"/\text{yr}$

● **Reusable:**  $7" \times 2.25" = 17.5 \text{ cu}'' \times 18 \text{ flashlights} \div 4 \text{ yr life} = 78.75 \text{ cu}''/\text{yr}$

Net:  $3,523 - 79 = 3,444 \text{ cu}'' \div 46,656 \text{ cu}''/\text{cu yd} = .074 \text{ cu yd}/\text{yr}$ ;  $3,444 \div 3,523 = 97.76\% \text{ volume reduction}$

### Weight of waste avoided: 394 lbs each year; 99% weight reduction

■ **Disposable:** "D" cell weighs 5 oz,  $106 \times 5 \text{ oz} \times 12 = 6,360 \text{ oz}$  per year  $\div 16 \text{ oz}$  for one pound = 398 lb/yr.

● **Reusable:** rechargeable flashlight weighs 1 lb  $\times 18 \text{ flashlights purchased} = 18 \text{ lbs}$ ,  $\div 4 \text{ yr life} = 4.5 \text{ lb}/\text{yr}$

Net:  $398 \text{ lbs} - 4.5 \text{ lbs} = 393.5 \text{ lb}/\text{yr}$  reduction;  $393.5 \div 398 = 98.9\% \text{ weight reduction}$ .

### Cost savings, not including avoided disposal fees: \$260 each year: 86% cost savings

■ **Disposable:**  $106 \text{ batteries}/\text{mo} \times 12 = 1,272 /\text{yr} \times 23.7\text{¢}$  ea = \$302 /yr

● **Reusable:** \$207 was spent purchasing 18 reusable flashlights.

Flashlights are guaranteed for one year, but a four year life has been experienced. Over four years, 5,088 batteries and \$1,208 in disposable battery purchase cost is avoided. Electricity used to recharge the batteries is reported insignificant compared to total hospital usage.

Net:  $\$1,208 - \$207 = \$1,041 \div 4 \text{ years}$  for an average of \$260 saved each year;  $\$1,041 \div 1,208 = 86.2\% \text{ cost reduction}$

**Indirect costs:** Currently, hospitals must manage alkaline batteries as hazardous waste. Significant reduction in volume and weight reduces disposal costs.

**Issues:** Staff must be trained on use of recharger. Electrical outlets must be convenient for nursing staff. Rechargeable flashlights with "low battery" indicators are recommended. With these measures in place, implementation has been successful.

Note: Minnesota Statute 115A.9155 applies to disposal of industrial batteries. Mercuric oxide and silver oxide as well as nickel-cadmium and lead-acid batteries purchased for use by government, industry, communications and medical facilities are covered. Manufacturers selling these batteries to these facilities are responsible for ensuring a system of collection and processing of these batteries by August 1, 1990.

Pilot collection for all other rechargeable batteries and appliances (primarily from households) must be in place by April 15, 1992. Rechargeable tools and appliances must have a rechargeable battery that can be easily removed after July 1, 1993.

Alkaline batteries sold in Minnesota may contain no more than 0.025 percent mercury by battery weight as of February 1, 1992. Although rechargeable batteries result in substantially less solid waste than their alkaline or carbon-zinc counterparts, it is difficult to compare the complete environmental impact of these three battery types. However, in Minnesota, rechargeable batteries are subject to mandatory collection which ultimately results in recycling or controlled hazardous waste disposal, while low-mercury and carbon-zinc batteries can be disposed in municipal solid waste.



## Use reusable, not single-use, pitchers on patient floors

Nurses must have individual pitchers of water available for patients on each floor of the hospital. Reusable, color-coded pitchers for each department are now used.

### Volume of compacted waste avoided: 19 cu yd /yr; 99% volume reduction

■ **Single-use:** The hospital threw out 5,500 single-use pitchers every year, 11 cases of 500/case. Assembly of container and handle required, separate components.

The volume of one container ( $\pi r^2 h = v$ )  $3.14 \times 2.5^2 \times 8 = 157 \text{ cu"}.$  x 5,500 pitchers/yr = 863,500 cu"

Handle - solid plastic, must be assembled, not autoclavable (steam sterilization), case  $80" \times 23.5" = 1,880 \text{ cu"} \times 11 \text{ cases/yr} = 20,680 \text{ cu"}/\text{yr}$

Lid - solid plastic, not autoclavable, case  $60" \times 14" = 840 \text{ cu"} \times 11 \text{ cases/yr} = 9,240 \text{ cu"}/\text{yr}$

$863,500 + 20,680 + 9,240 = 893,420 \text{ total cu"}/\text{yr}$ , minimum volume

● **Reusable:** The volume of the autoclavable, reusable pitcher is  $170 \text{ cu"}.$  It has a minimum life expectancy of 3 years. 180 were purchased.  $180 \times 170 \text{ cu"} = 30,600 \text{ cu"} \text{ every 3 years; } \div 3 = 10,200 \text{ cu"}/\text{yr}.$

Net:  $893,420 \text{ cu"} - 10,200 \text{ cu"} = 883,220 \text{ cu"}/\text{yr} \div 46,656 = 18.9 \text{ cu yd/yr volume reduction;}$

$883,220 \div 893,420 = 98.8\%$

### Weight of waste avoided: 414 lbs; 94% weight reduction

■ **Single-use:** One 500-count pitcher case has the following weights:

Pitchers, 10 lbs

Handles, 20 lbs

Lids, 10 lbs

$40 \text{ lbs} \times 11 \text{ cases used /yr} = 440 \text{ lbs/yr}$

● **Reusable:** Pitcher weighs 7 oz x 180 purchased  $\div$  min. 3 yr life =  $420 \text{ oz} \div 16 \text{ oz/lb} = 26 \text{ lbs/yr}.$

Net:  $440 - 26 = 414 \text{ lbs avoided /yr}; 440 - 26 \div 440 = 94.1\%$

### Cost savings, not including avoided disposal fees: \$1,445 /yr: 81% savings /yr

One 500 count case of each of the following costs:

Pitchers, \$49

Handles, \$69

Lids, \$43

■ **Single-use:** Cost =  $\$161 \times 11 = \$1,771 \text{ /yr} = \$148 \text{ /mo}.$

● **Reusable:** Cost =  $\$1.77 \text{ ea} \times 180 \text{ needed} = \$318, \div 3 \text{ yr life cycle} = \$106 \text{ /yr} = \$8.83 \text{ /mo}.$

Water, electricity and soap is calculated to cost approximately \$225 /yr

Net: Single-use ( $\$148 \times 12$ ) - ( $\$8.83 \times 12 + \$225$ ) = 1,445/yr savings

$\$1,445 \div \$1776 = 81\% \text{ savings /yr}$

**Indirect costs:** There was a decrease of labor in ordering, stocking and delivering for the purchasing and maintenance departments. No significant labor change to get reusables to kitchen because taken with other food cart items. Increase in loading/unloading dishwasher. No change in overall staff for the hospital due to implementation of this action.

**Issues:** Color-coding assures pitchers are returned to correct department. Reusable pitchers are stackable and are stored where single-use pitchers used to be kept.

## Change from disposable to reusable pads

When nursing staff changed from plastic-lined, fiber-filled disposable underpads used on patient beds to a reusable cotton underpad, patients reported an increase in comfort.

### **Volume of waste avoided: 44 cu yds each year: 92% volume reduction**

■ **Single-use:** 300 fewer cases of disposable pads are used each year. The cases measure 21" x 14" x 15" = 4410 cu" /case x 300 = 1,323,000 cu" ÷ 46,656 cu"/cu yd = 28 cu yd. This volume represents manufacturer's shipping volume, a minimum volume for the product. Actual disposal volume after use was observed to be a minimum of 70% greater. 28 cu yd ship. vol. x 70% = 19.6 cu yd., 28 cu yd + 19.6 cu yd = 47.6 cu yd/yr

● **Reusable:** Each pad measures 24" x 36" x 1/2" = 432 cu in., 768 pads were purchased. Pad life is estimated to be a minimum of 2 years. 432 cu in. x 768 = 331,776 cu in of waste every 2 years, ÷ 2 = 165,888 cu in of waste/yr. 165,888 ÷ 46,656 cu in/yd = 3.55 yards/yr. When worn out, these pads will be reused as rags and rag pads. When they are eventually thrown out net waste volume will be 47.6 cu yds - 3.55 cu yds = 44.05 cu yds net volume reduction/yr.  
47.6 - 3.55 ÷ 47.6 = 92.5% volume reduction/yr

### **Weight of waste avoided: 5,537 lbs each year: 97% weight reduction**

■ **Single-use:** Unused, disposable pads from one case weigh 19 lbs; 300 x 19 lbs = 5,700 total lbs. Due to fluid absorption, actual disposal weight would be higher. Minimum weight used.

● **Reusable:** 6.8 oz each, 768 purchased for 2 yrs = 2,611.2 oz/yr ÷ 16 oz/lb = 163.2 lbs/yr  
Net: 5,700 lbs - 163 lbs = 5,537 lbs net weight reduction/yr  
5,700 - 163 ÷ 5,700 = 97% weight reduction/yr

### **Cost savings, not including avoided disposal fees: \$5,021 each year: 67% cost reduction**

■ **Single-use:** Approximately 16,000 single-use pads, a cost of \$7,466, were thrown out each year.

● **Reusable:** \$4,440, reusable pad purchase cost ÷ 2 yr pad life = \$2,220 /yr plus \$225 in water, soap and electricity/yr = \$2,445/yr.  
Net: \$7,466 - \$2,445 = \$5,021 /yr cost savings ÷ \$7,466 = 67% cost reduction/yr

**Indirect costs:** Reduction in disposal of 44 cu yds of single-use pads at \$6.25 per cu yd = \$275/yr. However, this figure was not included in savings because contracted hauling volume for the facility was not changed. Labor cost of purchasing, checking-in, moving, storing and disposing of 16,000 single-use pads/yr decreased for purchasing and maintenance departments. Labor cost of washing and folding reusable pads increased for laundry department. These changes were not incorporated into the cost figure because, though labor for individual departments changed, labor costs for the hospital as a whole did not change. This action was integrated by the existing staff.



## Exit sign conversion

There are 18 exit signs throughout the facility, all lit continuously. Existing incandescent bulb sockets were converted to fluorescent. Fluorescent bulbs were found to last 10 times longer (2.5 yrs) than the hospitals incandescent exit sign bulbs (1/4 of one yr). Although most exit signs have 2 incandescent bulbs per exit sign, the hospitals fixtures contained one. It is worthy to note that conversion to fluorescent was still beneficial.

### Percent reduction of this waste stream: 89%

Incandescent count; 67 used/yr in facility

Fluorescent count; 18 needed for 2.5 yr; 7.2/yr; 89% count reduction

### Volume of waste avoided: .0034 cu yd; 80% volume reduction of exit lighting waste

15-watt incandescent bulbs = 3 cu" x 67 = 201 cu"/yr

7-watt fluorescent bulb = 3.75 cu" x 18 used in 2.5 yr = 27 cu"/yr

Ballast; 4 cu", life 5 yrs, 1 yr = 19% of total life, 4 cu" x 18 count = 72 x 19% = 14 cu"/yr

Net: 201 - 27 - 14 = 160 cu" ÷ 46,656 cu"/yd = .0034 cu yd/yr

201 cu" - (27 + 14 cu") ÷ 201 = 79.6% volume reduction

### Weight of waste avoided: 24 oz; 40% weight reduction of exit lighting waste

15-watt incandescent bulb; .8 oz x 67/yr = 54 oz/yr

7-watt fluorescent bulb; 1.15 oz x 18 bulbs for 2.5 yr ÷ 2.5 = 8.3 oz/yr:

Ballast; last 45,000 hrs (5 yrs); magnetic ballast wt. 7 oz; 19% life use/yr; 19% x 7 oz = 1.33 oz/yr/fixture.

Net: 18 x 1.33 = 24 oz/yr for total

54 oz/yr - (8.3 + 24) ÷ 54 = 40%

### Cost savings, not including avoided disposal fees: \$6/yr: 11% /yr cost savings

Incandescent bulbs cost \$0.64 ea x 67 = \$43/yr

Fluorescent bulbs cost \$2.50 ea x 18 = \$45 for 2.5 yrs, \$18/yr

Retrofit kits cost \$12.70 ea x 18 = \$228; conservative 10 yr life = \$23/yr

Electricity cost savings: \$3.85; 46% electricity cost savings

Incandescent: \$.05 /kWh x 15 watts = \$01.01 /1,000hrs. x 8.760 (8760 hrs/yr) = \$8.45 /yr

Fluorescent: \$.05 /kWh x 8 (7 watts for bulb + 1 watt for ballast) = .525 /1,000hrs x 8.76 = \$4.60

Net: (\$43 + \$8.45) - (\$18 + \$23 + \$4.60) = \$5.85/yr

\$5.85 ÷ \$51.45 = 11.4% /yr cost savings

**Indirect costs:** Labor - Each bulb change costs \$8 in labor. Replacing 67 incandescent costs \$536/yr. Replacing 18 fluorescents every 2.5 yrs costs \$144; or \$58/yr. Net labor cost change; \$478 savings. However, no staff changes were made at the hospital as a direct result of implementation of this action.

**Issues:** Although the hospital's incandescent bulbs listed a 2,500-hour life, that proved to be a maximum. Although fluorescents listed a 10,000-hour life, in continuous-burn applications they have lasted over 2 years (22,000 hrs). Loop type PL and straight tube mini bi-pin fluorescent lamps are both available for exit sign conversion.



## Replace incandescent floodlights with fluorescent floodlights

During remodeling, the hospital installed 87 compact fluorescent, recessed ceiling floodlights instead of recessed incandescent floodlights. Reported benefits of the change were source reduction, less heat build-up, lower maintenance costs and improved light quality.

The fixtures have been in place over 2 years. No bulbs have burned out. Approximately half are continuously lit and half are on a computerized timer.

### Volume of uncompact waste avoided: .1 cu yd; 94% volume reduction

Incandescent; a 60-watt bulb measured 7 cu" displacement, life 1000 hrs

Fluorescent; a 13-watt bulb measured 4 cu" displacement, life 22,000 hrs (over 2 yrs)

Ballast; last 45,000 hrs (5 yrs) and measures 8.9 cu".

Usage for 45,000 hours of one light:

Incandescent; 696 bulbs x 7 cu" = 4,872 /yr cu"

Fluorescent; 34.8 bulbs x 4 cu" = 139 cu"/yr

Ballast, 1 = 8.9 cu"; 5 yr life; 87 fixtures;  $87 \div 5 = 17.4$  prorated use/yr;  $17.4 \times 8.9 = 155$  cu"/yr

Net:  $4,872 - 139 - 155 = 4,578$  cu" avoided  $\div 46,656$  cu"/yd = .098 cu yd/yr

$4,872 - 155 \div 4,872 = 94\%$

### Weight of waste avoided: 26.5 lbs/yr; 64% weight reduction

Incandescent; 60-watt bulb weighs .95 oz x 696 used/yr = 661 oz/yr waste

Fluorescent; a 13-watt bulb weighs 1.75 oz; .5 life used /yr x 87 fixtures = 76.5 oz/yr/waste

Ballasts; life 45,000 hrs:

**Magnetic** ballast weighs 9.75 oz; 19% life used /yr = 1.85 prorated oz/yr x 87 lights = 161 oz/yr waste

**Electronic** ballasts weighs 2.30 oz; 19% life used /yr = .437 oz/yr x 87 lights = 38 oz/yr waste.

• Fluor. bulb (76.5) + Mag. bal. (161) = 237.5 oz/yr

• Fluor. bulb (76.5) + Elec. bal. (38) = 114.5 oz/yr

Net:  $661 - 76 - 161 = 424$  oz  $\div 16$  oz/lb = 26.5 lbs/yr

$661$  oz -  $238$  oz  $\div 661$  oz = 64%

### Cost savings, not including avoided disposal fees: \$268 /yr: 36% cost savings /yr

• Incandescent bulbs cost \$0.64 ea x 696 = \$445/yr

• Fluorescent bulbs cost \$2.51 ea x 34.8 prorated bulbs/yr = \$87/yr

• Ballast cost \$12.70 ea for conservative 10 yr life = \$1.27 prorated cost/fixture x 87 fixtures = \$110/yr

• Electricity savings; 60-watt incandescents (cost \$3 /1,000 hrs) were replaced by 14 watt fluorescent (cost \$.70 / 1000 hrs); 8760 hrs in one yr  $\div 1000 = 8.76$  kwatt; Yearly incandescent cost  $\$3 \times 8.76 = \$26$ /yr; Yearly fluorescent cost  $\$.70 \times 8.76 = \$6$ /yr;  $\$26 - \$6 = \$20$ /yr savings = **77% electricity cost savings.**

Net:  $(\$445 + 26) - (87 + 110 + 6) = \$268$  cost savings/yr;  $\$268 \div (\$445 + \$26) = 36\%$  savings/yr

**Indirect costs:** Labor for changing incandescent bulbs; \$8/change x 696 = \$5,568/yr. Labor for changing fluorescent bulbs; \$8/change x 34.8 = \$278/yr. A significant labor decrease for the maintenance department results from this action. However, no change was made in staff due to this action alone.

**Issues:** The maintenance staff discovered that some compact fluorescent units are sold with the ballast and bulb glued together as one unit. When the bulb burns out the entire lens and ballast must be thrown out. To avoid this unnecessary waste and expense, make sure the bulbs can be replaced.



## Use efficient flow shower heads

There are 33 showers in the hospital and long-term care center. By changing to efficient-flow fixtures, the hospital conserves water, energy and capital.

- The old shower heads used 3.5 gallons /min.
- The new shower heads use 1.5 gallons /min.

### **Volume of waste water avoided: 103,000 gallons /year: 57% volume reduction**

Approximately 2,100 showers lasting an average of 7 minutes each are taken at the facility each year.

**Old:** 3.5 gal./min x 7 min = 24.5 gal/shower x 2,100 showers = 51,450 gal/yr

**New:** 1.5 gal./min x 7 min = 10.5 gal/shower x 2,100 showers = 22,050 gal/yr

**Net:** 29,400 gallons saved;  $29,400 \div 51,450 = 57\%$  volume reduction

### **Cost savings, including avoided waste water treatment cost: \$89/yr: 57% cost reduction**

Water cost is \$1.70 /1,000 gal. Sewer charge is pegged to the number of gallons of water used and is \$.77 /1,000 gal.

Total cost of water used is \$2.47 /1,000 gal.

$29,400 \div 1,000 \times \$2.47 = \$73$  /yr

It takes 22 watt-hours to heat one gallon of water to 120°F x # gal heated ( $29,400 \div 2 = 14,700$  gal heated) =  $323,400 \div 1000$  (for kilowatt hours) = 323.4 kilowatt hours x watt hourly rate of \$0.05 /kilowatt = \$16; \$73 water and sewer savings + \$16 electricity savings = \$89

**Old:** 51,450 gal/yr x \$2.47/1,000 gal = \$127/yr

**New:** 22,050 gal/yr x \$2.47/1,000 gal = \$54/yr

**Net:** \$127 - \$54 = \$73 = 57% cost reduction

**Issues:** Although shower heads were replaced by efficient-flow fixtures, the timing of replacement was determined by existing shower head life-cycle maintenance. The hospital replaces shower heads when corrosion and mineral build up impair function. Old shower heads are given away for reconditioning and reuse. Aerators are used on faucets.

## Toxicity reduction by developing solution change

X-ray image quality was not compromised when the hospital changed to non-toxic "T2" chemistry. The new developer contains no hexavalent or trivalent chromium, is 95 percent acid-free, has no irritating fumes and does not damage clothing. The fixer is borate-free and the developer starter has a neutral pH.

### **Percent reduction of this toxic waste stream: 100%**

The hospital no longer uses acidic developer or fixer.

### **Volume of toxic waste avoided: 810 gallons /year**

10 gallons of fixer is used every 18 days = 203 gal/yr

10 gallons of developer is used every 6 days = 608 gal/yr

### **Cost savings, not including avoided disposal fees: Break even**

**Issues:** Improved worker safety and eliminating over 800 gallons of toxic waste were the reasons for the change. The product is manufactured by White Mountain Imaging, Webster, NH 03303 (603) 648-2124. It is handled by medical supply distributors nationwide.

---

## Change from straight to circular tubes for x-ray view boxes

Some X-ray view box models contain four straight fluorescent X-ray tubes, and all must be replaced when one bulb burns out. Updated versions contain only one circular tube. Life expectancy is the same, 2 years.

### **Volume of waste avoided: .01 cu yd/yr: 24% volume reduction /yr**

**Straight tube:** measures 1" dia x 17.25" long = 54.2 cu", x 4 tubes /fixture = 217 cu" x 18 fixtures ÷ 2 year life = 1,953 cu"/yr.

**Circular tube:** measures 1.25" dia x 33.5" circum = 165 cu", x 18 fixtures ÷ 2 year life = 1,485 cu"/yr.

Net: 1,953 cu" - 1,485 cu" = 468 cu", ÷ 46,656 cu"/cu yd = .01 cu yd/yr

1,953 cu" - 1,485 cu" ÷ 1953 cu" = 24% volume reduction

### **Weight of waste avoided: 1 lb/yr: 22% weight reduction**

**Straight tube:** 2.1 oz ea x 4 tubes/fixture x 18 fixtures ÷ 2 year life = 76 oz/yr

**Circular tube:** 6.5 oz ea x 18 fixtures ÷ 2 year life = 59 oz/yr; 76 - 59 = 17 oz, ÷ 16 oz/lb = 1.1 lb

17 oz ÷ 76 = 22% weight reduction

### **Cost savings: \$71 /yr: 44% annual cost savings**

**Straight tube:** 4 required /fixture x \$2.24 ea x 18 fixtures = \$161

**Circular tube:** 1 required /fixture x \$4.97 ea x 18 fixtures = \$90

Net: With replacement life the same, \$161 - \$90 = \$71/yr, \$71 ÷ \$161 = 44% cost savings /yr

**Indirect costs:** Less labor is required to service circular tube units than 4 tube units.



## Change to reusable cups

Use of single-use foamed polystyrene cups by staff was eliminated. The hospital provided high-quality, reusable plastic mugs embossed with the hospital's logo for all employees. Employees are responsible for their own mugs. Reusable cups are provided for all meetings. The hospital plans to phase out single-use cups in the facility in 1993.

### Volume of waste avoided: 26 cu yd/yr: 99.8% volume reduction

■ **Single-use cups:** Shipping volume is 6,084 cu" /case of 1000; Measured disposal volume of 50 cups is 1,287 cu"; 20 x 1,287 = 25,740 cu" for 1,000 cups (76% increase from shipping to disposal volume.) A minimum of 1,000 single-use cups were used/week. Allowing for settling in a dumpster, 90% of the measured disposal volume is used for calculations. 90% x 25,740 cu" = 23,166 cu" x 52.14 wks/yr = 1,207,941 cu"/yr

● **Reusable cups:** Since cups are the property of individual staff, and they must be replaced at their own expense, it is not anticipated that they will be thrown away. However, a 4-year functional life was assigned to the cups. Cups measure 3" dia. x 5" ht = 35.4 cu"; 200 cups were distributed, ÷ 4 yr life = 50 disposed/yr; 35.4 cu" x 50 = 1,770 cu"/yr  
Net: 1,207,941 cu"/yr - 1,770 cu"/yr = 1,206,171 cu"/yr ÷ 46,656 cu"/yd = 25.85 cu yd/yr; 1,206,171 ÷ 1,207,941 = 99.8% volume reduction

### Weight of waste avoided: 69 lbs/yr: 82% volume reduction

■ **Single-use:** 7 lbs /case of 1,000; 12 cases/yr x 7 lbs = 84 lbs/yr

● **Reusable:** 4.75 oz x average of 50 disposed/yr = 237.5 oz, ÷ 16 oz/lb = 14.8 lbs/yr  
Net: 84 lbs - 14.8 lbs = 69.2 lbs/yr avoided; 69.2 ÷ 84 = 82.3% volume reduction

### Cost savings, not including avoided disposal fees: \$94 /yr: A 58% cost savings/yr

■ **Single-use:** Cost \$13.50/case x 12 = \$162/yr

● **Reusable:** Cost \$1.35 ea x 200 = \$270, however future cost of purchasing single-use cups is eliminated. If the hospital decides to purchase new cups in 4 years (estimated life) instead of having employees purchase their reusable cups as is now the policy, the hospital cost savings would be \$162 x 4 = \$648, - \$270 = \$378 savings over 4 yr, = \$94 /yr savings; \$94 ÷ \$162 = 58% cost reduction.

**Indirect costs:** 26 cu yd waste abatement x \$6.26/yd = \$162 cost reduction. However, due to implementation of this measure alone, no change was made in the hospital's contracted hauling volume. The maintenance department has a considerable reduction in labor expense due to decrease in volume and weight of waste managed. Staff are responsible for washing out their own mugs, 1 minute per day. No staff changes.





## Change to bulk milk dispenser

Milk was served to patients in half-pint, plastic coated, gable-top milk cartons. The containers composed a major element of food service's waste. An average of 205 milk cartons were thrown out each day, 74,825 each year. Food service staff reduced this by changing to reusable cups and a bulk milk dispenser.

### Volume of waste avoided: 1.9 cu yds/yr: 7% volume reduction

■ **Single-use:** One 8-oz carton takes 17 cu in x 74,825/yr = 1,272,025 cu in/yr. Cartons are plastic coated cardboard, not locally recyclable. Actual disposal volume is greater than stacked volume used here.

● **Bulk container:** One 3-gallon (128-oz) container measures 11.5" x 8.25" x 8" = 759 cu in. Plastic liner separates from cardboard box, cardboard is locally recyclable. 8 oz x 74,825 = 598,600 oz/yr, ÷ 128 oz/gal = 4,676.6 gal/yr, ÷ 3 gal/container = 1,559 containers. 759 cu in x 1,559 = 1,183,170 cu in/yr.

Reusable glass measures 3.25" dia x 3.25" high = 8.58 cu in ea. x 105 disposed/yr = 901 cu in/yr

Single-use lid measures 3.25" dia x .001" thick = .0026 cu in ea. x 205 used/day x 365 = 195 cu in/yr; 60% increase in disposal volume observed, 60% x 195 = 117, + 195 = 312 cu in disposal volume/yr

Net: carton use, 1,272,025 cu in/yr - Bulk use (1,183,170 + 901 + 312) = 87,642 cu in/46,656 cu in/cu yd = 1.88 cu yd, 6.89%

The cardboard is recycled but 59,158 cu in of currently non-recyclable plastic remains. Because the cardboard of the bulk containers is locally recyclable while the cartons are not, 26 cu yds/yr, a 95% volume reduction, is kept from the dumpsters through the use of bulk milk.

### Weight of waste avoided: 740 lbs/yr: 32% weight reduction

■ **Single-use:** One 8-oz carton weighs .5 oz x 74,825/yr = 37,415 oz, ÷ 16 oz/lb = 2,338 lbs/yr.

● **Bulk container:** One 3-gallon (128-oz) container weighs .81 lbs of cardboard and .015 lb of plastic for a total of .825 lbs, x 1,559 containers/yr = 1,286 lbs/yr.

Reusable glass weighs 2.1 oz ea., 205 used, life 2 yrs = 103 disposed/yr. 103 x 2.1 oz = 216 oz ÷ 16oz/lb = 13.5 lbs/yr

Single-use glass cover weighs .20 lb for 50, 205 used/day 365 = 74,825/yr ÷ 50 = 1,497, x .20 lb = 299 lbs/yr

Net: 2,338 lbs/yr - 1,286 - 13.5 - 299 = 739.5 pounds prevented, ÷ 2,338 lbs = 31.6% weight reduction due to source reduction.

Because virtually all of the weight of the bulk milk containers is recycled, the change represents a 99% disposal weight reduction due to recyclability.

### Cost: A \$98/yr increase: 1% cost increase

■ **Single-use:** Cost 12¢ a carton x 74,825/yr = \$8,979/yr

● **Bulk container:** One 3-gallon (384-oz) container costs 11.6 cents/serving; 74,825 servings ÷ 48 = 1,559 3 gal containers/yr, x \$5.57 = \$8,683/yr. The dispenser furnished by the milk distributor

Reusable glasses cost \$48/case, 80 to a case or 60¢ ea., 205 used/day. Two year life; 103 x .60 = \$62/yr

Single-use cup lids are used to cover glasses, \$9.15 a case of 3,000 = .00305¢ ea x 205 used/day = .62¢ x 365 = \$228/yr

Washing, soap, water and energy use for 8 additional racks run/day = \$104/yr

Net: \$8,683 + \$62 + \$228 + \$104 = \$9,077/yr

\$8,979 for cartons - \$9,077 for bulk = -\$98, a 1% cost increase

**Indirect costs:** Because the hospital's recyclable material is picked up without charge and the bulk milk container is recyclable, 26 cu yds of waste is not disposed. 26 cu yd x \$6.25 cu yd = \$162/yr savings. However, implementation of this measure alone did not result in a decrease in contracted hauling volume for the facility. Labor for handling 75,000 cartons is replaced by handling 1,600 three-gallon containers plus the 75,000 glasses and lids a year. More labor is spent using bulk milk; however, the change was integrated by the existing staff.

**Issues:** Bulk milk may be more cost-effective at other facilities. Cartons usually range in price from 12 to 13 cents each. They are 12 cents for this facility. 3-gallon bulk can be less than \$5.57 each.



## Change to milk pouch

The cafeteria changed from 8 oz milk cartons to milk pouches. Staff members puncture the self-sealing bag with a small straw before serving.

### Volume of waste avoided: 6.2 cu yd/yr: 87% volume reduction

■ **Cartons:** 50 cartons used/day x 365 = 18,250 cartons/yr x 17 cu in/carton = 310,250 cu in/yr. Straws are paper-wrapped, a box of 400 measures 9" x 5.5" x 6" = 279 cu in.,  $18,250 \div 400 = 45.6$  boxes of straws/yr, x 279 cu in/box = 12,729 cu in/yr.  $310,250 + 12,729 = 322,979$  cu in/yr

● **Plastic pouches:** 50 pouches used/day x 365 = 18,250 pouches/yr x 2.3 cu in = 41,975 cu in/yr. Straws are .056194 cu in ea. including packaging,  $18,250 \times .056194 = 1,025.5$  cu in/yr.

Net:  $41,976 + 1026 = 43,002$  cu in/yr

$322,979 - 43,002 = 289,977$  cu in/ $46,656$  cu in/yd = 6.2 cu yd/yr, 87% volume reduction

### Weight of waste avoided: 472 lbs/yr: 78% weight reduction

■ **Cartons:** 18,250 cartons/yr at .5 oz = 9,125 oz/yr., 18,250 straws, 400 weigh 12.8 oz,  $18,250 \div 400 = 45.6$ , x 12.8 oz = 584 oz.,  $9,125 + 584 = 9,708$  oz/yr

● **Plastic pouches:** 18,250 pouches/yr at .11 oz = 2,007 oz/yr., 18,250 straws, 400 weigh 3.3 oz,  $18,250 \div 400 = 45.6$ , x 3.3 oz = 150 oz.,  $2,007 + 150 = 2,157$  oz/yr

Net:  $9,708 - 2,157 = 7,551$  oz  $\div 16$  oz/lb = 472 lbs/yr.;  $7,551$  oz  $\div 9,708$  oz = 77.8 % weight reduction

### Cost savings: \$276/yr: 12% cost reduction

■ **Cartons:** Cost 12¢ each x 18,250 = \$2,190; Straws cost \$2.03 for 400,  $18,250 \div 400 = 45.6$ , x \$2.03 = \$92.57/yr; \$2,190 + \$93 = \$2,283 /yr

● **Plastic pouches:** Cost 11¢ each x 18,250 = \$2,007; Straws are included;

Net:  $\$2,283 - \$2,007 = \$276$  /yr;  $\$276 \div \$2,283 = 12\%$  cost reduction

**Indirect costs:** A reduction in disposal of 6.2 cu yd of waste x \$6.25 = \$39/yr. Contracted hauling volume was not changed for the facility due to implementation of this measure alone. More pouches fit into a smaller space in the walk-in cooler, more efficiently using space. No appreciable labor change for dietary department. Due to less waste, there is a labor savings for the custodial department. No staff changes.



## Reusable decubitus care mattresses

“Egg-crate” mattresses are designed to distribute pressure so that decubitus ulcers do not develop on patients’ skin. Typical egg-crate mattresses cannot be reused by another patient. The reusable mattresses accomplish the same goal but create much less waste, do not require mattress pads and save money.

### Volume of waste avoided: 43 cu/yds: 97% volume reduction

- **Single-use:** 26 cases of 12 thrown out each year = 312; 30" x 80" x 2.75" ea = 6,600 cu" x 312 used/yr = 2,059,200 cu"/yr
- **Reusable:** The dense foam decubitus-care insert is warranted for 5 years. They measure 27" x 72" x 3.25" = 6,318 cu in. Eight were purchased to serve the average need. Standard egg-crate mattresses will be used if need exceeds supply of reusable. Over time, the hospital will replace all standard mattresses with reusable, Bio Gard Therapeutic Mattresses. To be conservative, a 1-year life was assigned to the decubitus care component of the mattress, though it is warranted for 5 years. 8 needed ÷ 1 year life = 8 /yr, x 6,318 cu" ea = 50,544 cu"/yr. Only the volume of the decubitus-care insert and single-use egg-crate overlay are used for calculations. Note: The whole Bio Gard mattress has replaceable components, so disposal volume is likely to be less than that of a whole, standard mattress.  
Net: 2,059,200 - 50,544 = 2,008,656 cu" ÷ 46,656 cu"/cu yd = 42.9 cu yd/yr; 2,008,656 ÷ 2,059,200 = 97% volume reduction.

### Weight of waste avoided: 601 lbs: 96% weight reduction

- **Single-use:** 2 lb x 312 = 624 lb
- **Reusable:** 2.8 lb for decubitus care portion x 8 /yr = 22.4 lb  
624 - 23 = 601 lb/yr; 601 ÷ 624 = 96% weight reduction

### Cost savings, not including avoided disposal fees: \$879 /yr: 62% cost reduction /yr

- **Single-use:** Cost \$4.56 ea x 312/yr = \$1,423 /yr
- **Reusable:** Cost of entire mattress \$230 each x 8 = \$1,840 ÷ 5 yr life = \$368 /yr; Cost of inserts, \$22 ea x 8/yr = \$176 /yr  
Net: \$1,423 - (\$368 + \$176) = \$879 cost reduction; \$879 ÷ \$1,423 = 62% cost reduction

**Indirect costs:** Volume and weight waste reduction results in lower disposal costs, (43 cu yd x \$6.25/ yd = \$269); however, contracted hauling volume was not decreased due to implementation of this measure alone. Purchasing and maintenance departments have decreased labor demand because of the change. No staff changes resulted, however, so overall labor costs for the hospital did not change. The reusable decubitus-care mattress does not require use a mattress pad. When all old-style mattresses are changed over, the change will result in an additional \$2,445 /yr savings, the current cost of using underpads.



### **Reusable diapers**

Although the hospital supported this action, implementation was delayed. Several styles of reusable diapers were considered; however, commercial reusable diapers that would hold up to the hospital's laundry procedures, did not stain with meconium and were consistent in preventing leakage were not found. The hospital is continuing its search for a reusable diaper.



### **Reusable soup bowls**

The dietary department is phasing in the use of reusable tableware over time to assure that existing staff can integrate the changes. The change to reusable bowls from single-use ones looks functional at this point, and implementation is expected to take place.



### **Reink printer ribbons**

Reinking of ribbons and remanufacture of photocopy and printer cartridges were identified as viable source reduction measure. The hospital is currently researching remanufacturers and expects savings of 33 to 50% over current costs.



### **Senior citizens make use of old electronic equipment**

The hospital collects from others and also gives its own old electronic equipment to nursing home residents who disassemble, sort and recycle the components. Though this use of old electronic equipment results in the end of its functional life, reuse of the equipment in this way gives valued activity to the residents and accomplishes recycling of the components.

The hospital has also had these source reduction measures in place:

- Reusable bed pans
- Reusable emesis basins
- Reusable male urinal basins
- Reusable patient eating utensils
- Reusable sterilization trays
- Double-sided copying
- Reusable isolation and surgical gowns

### **In addition**

As a result of the hospital's source reduction and recycling efforts, contracted garbage hauling services were decreased from one 6-cu-yd dumpster five times a week to two times a week. This is a 60 percent decrease in contracted garbage hauling service volume. Yearly garbage hauling expense decreased \$5,244.

All changes took place without additions to hospital staff. In fact, after implementing their integrated waste management program the hospital eliminated two staff positions in the maintenance department.

As a result of reduction actions alone, the hospital is preventing 245 cubic yards and over 10,700 pounds of waste. Not including the savings from avoided disposal fees, these actions result in a \$11,030 yearly cost savings for the hospital.

When the \$5,244 hauling expense savings due to implementation of reduction and recycling is added to the \$11,030 savings due to reduction, the total savings for the hospital is over \$16,270 each year.

# Source Reduction

## A community newspaper case study

Facility:

### **Herald Review**

301 1st Avenue NW

Grand Rapids, Minnesota 55744

The Herald Review publishes a bi-weekly newspaper with a circulation of 8,000 and a weekly advertiser with a circulation of 20,000.

This business made a commitment to source-reduce its waste as much as possible. Secondly, what the staff members could not reduce they committed themselves to recycle.

As a result of their reduction measures alone, they are keeping 31 cubic yards and 25,150 pounds of waste out of their community's landfill each year. Not including the savings from avoided disposal fees, these measures result in a \$12,914 yearly cost savings for the business.

Reduction is defined as any activity that reduces waste at its source. Employees

examined their own waste stream and generated ideas to accomplish reduction. As they looked at their waste stream, they asked themselves the following questions.

- ▼ Where can I reduce the amount or the toxicity of material used to accomplish any task?
- ▼ Are there existing or new products I can reuse over and over again?
- ▼ Are there existing or new products that are repairable, refillable or more durable to give a longer useful life?

These are the three pillars on which they based their reduction program.

The publisher, Charlie Johnson, and the circulation manager, Ron Oleheiser, provided expertise and motivational staff leadership. Kenneth Brown, reduction specialist at the OEA, compiled this case study and facilitated staff meetings where recently implemented or potentially beneficial reduction measures were identified. The results of the businesses teamwork are contained within this report.

## Use end rolls of paper stock

Newspaper stock arrives on large spools. When the paper on the spool is wound down, it is replaced so the spool does not run out of paper during a printing run. A local ceramic packaging firm buys the newspaper's leftover spools and uses the paper for packing material in place of styrofoam pellets, an excellent example of waste exchange.

**Percentage reduction of this waste stream: 100%**

None of this waste paper is thrown into the dumpster.

**Volume of (compacted) waste avoided: 9.7 cu yds/year**

This measurement is taken from a factory roll. This volume is extremely conservative because measurements were taken from new rolls, not disposal volume of used rolls.

**Weight of waste avoided: 7,537 lbs/year**

**Cost savings before avoided disposal fees: \$1,809 /year from sales**

currently sold for 24¢ a lb.

$\$1,809 \div .24 = 7,537 \text{ lbs}$

Implementation of this measure resulted in a 6.4-percent savings in paper roll cost.

---

## Reduce paper, ink and labor waste caused by overruns

The circulation manager made a concerted effort to determine the accurate count of publications needed for distribution. Overruns of 250 copies per publication are now decreased to no more than 50 overruns per publication. As a result, approximately 20 rolls of paper are saved each year.

**Percent reduction of this waste stream: 80%**

**Volume of compacted waste avoided: 19 cu yds/year**

20 rolls saved x [volume of cylinder= $\pi r^2 h$ ]  $3.15 \times 20''^2 \times 35'' = 44,100 \text{ cu in} \div 46,656 \text{ cu in for one cu yd} = .945 \text{ cu yd/roll} \times 20 \text{ rolls} = 18.9 \text{ cu yds}$ . This volume is extremely conservative because measurements were taken from new rolls, not disposal volume of printed, folded newspaper.

**Weight of waste avoided: 17,000 lbs/year**

20 rolls saved x 850#/roll = 17,000#

**Cost savings before avoided disposal costs: \$7,300 per year.**

One roll of 35" wide paper costs \$350 x 20 rolls saved each year = \$7,000.

Estimate of ink cost savings: \$45

Estimate of labor cost savings: \$250

$7,000 + 45 + 250 = 7,295$

Implementation of this measure resulted in a 2.5-percent savings in publication paper cost.



## Reuse of waste ink

Rather than dispose of excess colored and black ink, The staff collects in catch pans and adds it to the respective hoppers. When a colored ink becomes too contaminated, it is added to the black ink hopper. Through this measure all ink is used.

**Percent reduction of this waste stream: 100%**

**Volume of waste avoided: 250 gallons/yr**

190 gallons/year of black ink  
60 gallons/year of colored ink

**Weight of waste avoided: 2,100 lbs/year**

one gallon of ink equals approximately 8.5 lbs  
1,615 lbs/year of black ink  
510 lbs/year of colored ink  
 $1,615 + 510 = 2,125$  lbs

**Cost savings not including avoided disposal fees: \$2,615**

\$615.60 per year black ink  
\$2,000 per year colored ink  
If this ink were not reused, it would be classified a hazardous waste.

Implementation of this measure resulted in a 17-percent savings in ink cost.

**Issues:** The newspaper staff expressed the desire to change from petroleum-based to non-toxic soy-based inks. Research showed that soy black ink is cost-competitive, but colored is not. Since combining inks is a source reduction requirement for the paper, when economically feasible the change will be made.

---



## Roll own film

Since the newspaper works under a deadline, many unshot frames on pre-rolled film were often wasted when the film had to be developed. Now, the reporters roll their own film and load only the number of frames needed for the day. Through this measure, newspaper also switched from single-use to refillable film canisters.

**Percent reduction of this waste stream: 10%**

The newspaper is using less film

**Cost savings: \$60 /year**

Implementation of this measure resulted in a 10-percent savings in film costs.

**Issues:** Reporters take pleasure from the fact that they can roll the number of shots and film speed to suit the job at hand, without wasting material.



## Reduce chemicals needed in film developing

The newspaper was using fresh chemicals for each photograph developing session. One gallon of developer was used each week. Since these chemicals were far from exhausted, the photography staff experimented by pouring this solution back into the bottle instead of down the drain. Through reuse, they found that life of developing solution was extended dramatically. One gallon of developer now lasts 3 weeks.

**Percent reduction of this waste stream: 66%**

**Volume of waste avoided: 35 gallons/year**

$$52 - 17 = 35$$

**Weight of waste avoided: 210 lbs/year**

$$6 \text{ lbs for each gallon} \times 35 \text{ gallons used per year} = 210 \text{ lbs}$$

**Cost savings, not including avoided disposal fees: \$140 /year**

$$\text{one gallon costs } \$4$$

$$\$4 \times 35 = \$140$$

Implementation of this measure resulted in a 66-percent savings in developing solution costs.

---

## Reuse paste-up sheets

Ruled paste-up sheets are used to lay out newspaper pages. As a source reduction measure, the camera-ready copy and posters are peeled off the paste-up sheets so the paste-up sheets can be reused again and again. Sheets are reused an average of 6 times. Through this measure, use of over 6,700 sheets per year is cut to 1,000.

**Percent reduction of this waste stream: 85%**

**Volume of compacted waste avoided: .4 cu yd/year**

$$1,000 \text{ sheets} = 6.5" \times 25" \times 20.5" = 3,331 \text{ cu in}$$

$$5.7 \times 3,331 = 18,986 \text{ cu in} \div 46,656 \text{ cu in for one cu yd} = .4 \text{ cu yd}$$

**Weight of waste avoided: 285 lbs/year**

$$1,000 \text{ sheets} = 50\#$$

$$5.7 \times 50\# = 285$$

**Cost savings not including avoided disposal costs: \$570 /year**

$$.10 \text{ cost per sheet} \times 5,700 \text{ sheets not purchased} = 570$$

Labor cost to peel sheets is reported insignificant because staff uses the activity to fill down time that occurs during the production process.

Implementation of this measure resulted in a 85-percent savings in paste-up sheet costs.



## Reuse toner cartridges for computer printout and photocopier

Empty cartridges are refilled and rebuilt by a professional re-inker.

**Percent reduction of this waste stream: 75%**

Cartridges are refilled for reuse 3 times, then recycled.

**Volume of compacted waste avoided: .49 cu yds/year**

$11" \times 7" \times 16.5" = 1,270 \text{ cu in} \times 18 = 22,869 \div 46,656 = .49 \text{ cu yd}$

**Weight of waste avoided: 27 lbs/year**

1.5 lbs per unit x 18

**Cost savings before avoided disposal costs: \$900 /year.**

Two replacement cartridges are required each month. New ones cost \$105 each.  $24 \times \$105 = \$2,520$

Rebuilding one costs \$54.95 each.

Because new cartridges are now used once then reused 3 more times, new purchase is down to 6 cartridges per year. Re-inking occurs 18 times.

$6 \text{ [new]} \times \$105 = \$630$     $18 \text{ [refilled]} \times \$54.95 = \$989$

$\$630 + \$989 = \$1,619 - \$2,520 = \$901 \text{ saved}$

Implementation of this measure resulted in a 35-percent savings in cartridge costs.

---



## Use narrow ruled reporter's notebooks

By switching from wide-ruled to narrow-ruled reporters' notebooks, the newspaper cut purchase of notebooks by half.

**Percent reduction of this waste stream: 50%**

**Volume of waste avoided: .83 cu yd/year**

Using 144 fewer notebooks each year

**Weight of waste avoided: 34 lbs/year**

2 lbs 13 oz per dozen X 12 = 33.75 lbs

**Cost savings: \$96 /year**

Implementation of this measure resulted in a 50-percent savings in notebook costs.



## Reuse of single-sided copy paper

The staff uses the remaining blank side of used paper for note pads and bundle labels.

**Percent reduction of this waste stream: 100%**

All single sided paper is eventually used.

**Volume of compacted waste avoided: .15 cu yd**

**Weight of waste avoided: 120 lbs**

**Cost savings not including avoided disposal fees: \$180 /year.**

As a result of implementing this measure NO paper is purchased for labeling, a 100-percent cost savings.

---



## Change to reusable cloth towels from disposable paper towels

There are four restrooms in the newspaper building. By changing to cabinets dispensing cloth rolled towels, the newspaper derived a financial as well an aesthetic benefit. Litter from the restroom floors disappeared, as did the large trash can. Because there was not room to hang the cabinet in the press room, one paper towel dispenser was kept there.

**Percent reduction of this waste stream: 80%**

**Volume of waste avoided: .66 cu yds/year**

Volume measurements were taken from new boxes of towels. Used towels take up significantly more volume. A new box of towels measures 18" x 12" x 12" = 3,888 cu in. x 8 (the number of boxes of towels kept out of the landfill) = 31,104 cu in ÷ 46,656 (for yds) = .66

**Weight of waste avoided: 135 lbs/year**

**Cost savings not including avoided disposal fees: \$120 /year**

Implementation of this measure resulted in a 33-percent savings in towel costs.

---



## Use blank, excess mailing labels

The newspaper contracts for its mailing list to be put on mailing labels. There are often unused labels remaining on a partially used sheet. Newspaper staff decided to trim off these unused labels and use them on old manila file folders in need of new labels. The labels are used and the folders are given new life.

**Cost savings is approximately \$20 /year**

From reduction in purchasing labels and does not including cost savings due to reused folders.

As a result of this measure NO labels are purchased, a 100-percent cost savings.



## Coordinate reporters' activities

More effort was made to plan reporters' itineraries so that stops were logical rather than haphazard.

Cost savings: \$200 /year

Implementation of this measure resulted in a 16-percent savings in reporters' travel budgets.

---



## Reuse aluminum printing plates

5,000 24" x 36" aluminum sheets are used each year. The printing plates are sold for reuse as construction sheeting (waste exchange). Any not sold for reuse are recycled.

**Volume of waste avoided: 1.1 cu yd of solid aluminum /year**

1,000 plates are 12" x 24" x 36" = 10,368 cu in x 5 = 51,840 cu in/yr ÷ 46,656 cu" in one yd = 1.1 cu yds/yr

**Weight of waste avoided: 4,250 lbs/year**

1,000 sheets weigh 850 lbs, x 5 = 4,250 lbs/yr

**Cost savings before avoided disposal fees: \$1,200 per year in sales**

Implementation of this measure resulted in a 14-percent savings in plate costs.

**Issues:** Staff recognized that current reuse and recycling of the plates was valuable, but due to the reduction program they pursued reuse a step further. The manufacturer was contacted to see if the plates could be taken back, re-buffed and re-filmed so that newspapers could simply use them again. The outcome is unknown at this time, but it demonstrates the depth to which staff has integrated concepts of reduction. Because this measure has been in place some time, it was not included in the total cost, volume and weight of waste avoided.

---

## In addition

As a result of the newspaper's source reduction and recycling efforts, container services were decreased from three 12-cu-yd dumpsters per week (3 x 12 = 36 cu yd/wk) to three 30-gallon trash cans twice a week (3 x 30 x 2 = 180 gal x 231 cu" in one gal = 41580 cu"/wk ÷ 46656 cu"/yd = .89 cu yd/wk.) This is a 97-percent reduction in contracted hauling volume that cut garbage hauling expense by \$3,900 per year.

Since much less time is now spent dumping office trash cans into the dumpster, cleaning service expense was consolidated, resulting in a further \$134 savings each month or \$1,608 per year. Total disposal and cleaning service savings is \$5,508. When added to the \$12,914 savings which result from source reduction measures, the total waste management program saves over \$18,400 /year.

Note: The Herald Review has always used reusable mugs.

# Source Reduction

## A case study: County courthouse and garages

### Itasca County Courthouse

123 NE 4th Street

Grand Rapids, MN 55744

Itasca County is located in north central Minnesota, has a population of 42,000 and is known for its forests and scenic waterways. It contains the much of the upper watershed for the Mississippi River. Its major industries are timber and tourism.

Itasca County government made a commitment to source-reduce the waste it generated. Secondly, what could not be prevented was targeted for recycling.

The project demonstrates source reduction in practice. It shows that reduction is a realistic goal for county governments and that it can be measured on a product-by-product basis.

A staff of 350 in the courthouse and the road and bridge department reduced the amount of waste they generated by approxi-

mately 13 percent. They prevented 122 cubic yards and 9,255 pounds of waste. Not including the savings from avoided disposal fees, these actions resulted in a \$46,198 yearly cost savings.

Reduction is defined as any activity that reduces waste at its source. Staff members examined their own waste stream and brainstormed ideas to accomplish reduction. As they looked at their waste stream, they asked themselves the following questions:

- ▼ Where can I **reduce** the amount or the toxicity of material used to accomplish any task?
- ▼ Are there existing or new products I can **reuse** over and over again?
- ▼ Are there existing or new products that are repairable, refillable or more durable to give a **longer useful life**?

These are the three pillars on which they based their efforts to reduce the amount of waste generated at their organization. The specific actions they employed are described in this report.

## **Acknowledgement**

Implementing source reduction methods takes teamwork. This project is a team effort, and most of the people listed below had firsthand experience implementing the reduction methods reported here.

Itasca County Courthouse/Road and Bridge Department Solid Waste Reduction Committee:

Terry Greenside, Committee Chair, Itasca County Zoning/Solid Waste Officer/Sanitarian

Robert R. Olson, County Coordinator/Human Resources Director

Rick Johnson, Purchasing Clerk, Road and Bridge Department

Walt Mandich, Master Mechanic and Purchasing Agent, Road and Bridge Department

Harold Goggeye, Chief Maintenance Supervisor

Loren Gelle, Environmental Specialist

Lois Ness, Office Services Supervisor

Connie Arezzo and Lisa Skelly, Central Purchasing Clerks

Ron Wilke, Assistant Chief Custodian

Mary Jo Eckholm, Solid Waste Program Assistant

Judy Pittack and Cindy Miltich, Public Health Nurses

Linda Taylor, Management Information Systems Director

Doug Veit, District Forester

Connie Swanson, Clerk Treasurer's Office

**Thanks also to:**

The Itasca County Board of Commissioners

Ann Franklin and Alyce McLane of The Neutral Corner Coffee Shop

Barb Loida of the Minnesota Technical Assistance Program (MnTAP)

Brett Smith, Jan Gustafson, Barbara Johnson, Mary Stangler and William D. Lauer for project support and Harvey B. Winthrop, Ideal Market, Duluth, for weighing and measuring boxes of polystyrene cups and other items.

These people all believe in reduction and put time, thought and effort into proving its efficacy.

Technical support for the initial case study was provided by Pamela Winthrop Lauer of the OEA. Technical support for this update was provided by Kenneth Brown of the OEA.

**Itasca County Government**  
**Waste Abatement and Cost Savings**  
**Summary of Totals**

Volume of waste avoided: 122.5 cu. yd/year

Weight of waste avoided: 9,255 lbs/year

Amount of dollar savings per year, not including avoided disposal costs: \$46,544/year

**Additional money potentially saved through avoided disposal costs at \$25/4 cubic yards: \$702/year**

Waste disposal for the courthouse is charged on a flat-fee basis. The \$25-per-4-cubic-yards figure is an estimated volume-based fee included for comparative purposes only. It is derived from the fact that it is not uncommon in Minnesota for a hauler to charge \$100/month to pick up a 4-cubic-yard dumpster once a week. The courthouse dumpster is 4 cubic yards. The Itasca County landfill tipping fee is \$55/ton.

**Estimate of the organization's waste abatement due to source reduction:**

The solid waste generated in the courthouse and 16 road and bridge department garages (employing around 350 people) was estimated to be approximately 880 cubic yards per year before the program. Reduction due to source reduction measured on a product-by-product basis was 112 cubic yards per year;  $880 \text{ cu yd/yr} - 112 \text{ cu yd/yr} \div 880 \text{ cu yd/yr} = .873$  or a **12.7% reduction in solid waste**.

The Courthouse/Road and Bridge Department committee that implemented these measures also initiated a "Reduction Workshop" that committee members conducted for other employees. This was crucial in both gaining staff participation and informing the staff of the program.



## Use reusable-component forced-air filters

There are 140 filters used to clean air as it circulates in the county courthouse. Consumption was 1,680 single-use filters a year. To reduce solid waste, reusable steel frames with steel wire filter supports were purchased. Now, all that is disposed is the filter medium. These filters result in substantial waste and cost reduction. The calculations are based on a conservative estimate of a 10-year life for the reusable frames. Manufacturers estimate they will last for the life of the building and can then be recycled.

### Volume reduction of waste stream: 25.83 cu yd/yr; a 85% volume reduction

- **Single-use:** Four different sizes of single-use filters are used in the courthouse, 1,680 single-use filters per year for a total volume of 30.33 cu yd/yr.
- **Reusable:** The same number of filters (1,680) is still needed with reusable frames, but waste is generated by the filter medium only. The total waste volume is  $(25" \times 20" \times 1/4") \times 1,680 = 210,000 \text{ cu}^3/\text{yr} \div 46,656 \text{ cu}^3/\text{yd} = 4.50 \text{ cu yd/yr}$   
Waste volume avoided:  $30.33 \text{ cu yd/yr} - 4.50 \text{ cu yd/yr} = 25.83 \text{ cu yd/yr}$   
Percentage change:  $30.33 \text{ cu yd/yr} - 4.50 \text{ cu yd/yr} \div 30.33 \text{ cu yd/yr} = 85\% \text{ volume reduction per year}$

### Weight of waste avoided: 1,610 lbs avoided per year; a 88% weight reduction

- **Single-use:** 1 case = 12 filters = 13 lbs; 1,680 filters needed/yr;  $1,680 \text{ filters} \div (12 \text{ filters/case}) = 140 \text{ cases/yr} \times 13 \text{ lbs} = 1,820 \text{ lbs/yr}$ .
- **Reusable:** 1 filter medium = 2 oz; 1,680 filters needed/yr;  $(1,680 \times 2 \text{ oz}) \div (16 \text{ oz/lb}) = 210 \text{ lbs/yr}$   
Weight avoided;  $1,820 \text{ lbs/yr} - 210 \text{ lbs/yr} = 1,610 \text{ lbs/yr}$   
Percentage change:  $1,820 \text{ lbs/yr} - 210 \text{ lbs/yr} \div 1,820 \text{ lbs/yr} = 88\% \text{ weight reduction}$

### Cost Savings: \$783/yr; a 46% cost savings

- **Single-use:** (Four different size filters);  $(216 \times \$0.86 \text{ filter}) + (168/\text{yr} \times \$0.98 \text{ filter}) + (768/\text{yr} \times \$0.98 \text{ filter}) + (528 \times \$1.16 \text{ filter}) = \$1,715.52/\text{yr} = \$1,716/\text{yr}$
- **Reusable:** Material cost for each filter change = \$0.47/roll; the roll is easily cut on-site to fit different lengths;  $1,680 \text{ filter changes} \times \$0.47 = \$789/\text{yr}$   
Initial purchase cost for reusable filter frames = \$1,436; cost of frames  $\$1,436 \div 10 \text{ year life} = \$144/\text{yr}$ ;  $\$789 + \$144 = \$933/\text{yr}$   
Single-use cost  $\$1,716 - \text{reusable cost } \$933 = \$783/\text{yr savings}$   
Percentage change  $\$1,716 - \$933 \div \$1,716 = 46\% \text{ cost savings}$

Payback for installing reusable component filters occurs after: Disposable filter cost  $(\$1716/\text{yr})/12 \text{ months} = \$143/\text{mo}$ ; reusable filter purchase and use cost is \$2,225 for the first year;  $\$2,225/(\$143/\text{mo}) = 15.6 \text{ months for payback}$ .

### Additional costs

**Labor:** The maintenance department found that it takes approximately 15 percent less time to service the reusable filters when compared to the single-use filters. Handling the extra 26 cu yds and 1,600 pounds of waste generated by 1,600 single-use filters is more time-consuming. There was, however, no labor cost change for the facility as a whole due to implementation of this action.

**Disposal:**  $26 \text{ cu/yds} \times \$6.25/\text{cu yd for disposal} = \$162/\text{yr potential savings}$ . Hauling service was not reduced due to this action alone.





## Use completely reusable forced-air filters

There are 60 forced-air filters in 16 Road and Bridge Department garages. They are changed an average of once a week. The reusable air filters are made of aluminum and are washed with high-pressure water equipment. With proper care, the filters will last the life of the building and are completely recyclable. Before the switch to reusable filters, the Road and Bridge Department garages landfilled approximately 3,120 single-use air filters each year.

### Volume of waste avoided: 53.5 cubic yards/year; a 99% volume reduction

- **Single-use:** Filters measure 16" x 25" x 2" x 3,120 used/yr = 2,496,000 cu in/yr. This figure represents shipping volume. Shipping cartons are tightly packed, when filters are disposed, they take up significantly more volume. To be conservative, shipping volume is used for calculations.
- **Reusable:** No solid waste from filter. Soap is only used with the washer when filters are unusually greasy. A minimal amount of solid waste is created from the soap container.

### Weight of waste avoided: 1,040 lbs/year; a 99% weight reduction

- **Single-use:** A case of 24 disposable filters weighs 8 lbs x 130 cases = 1,040 lbs
- **Reusable:** No solid waste from filter. Minimal amount of waste from soap container.

### Cost savings before avoided disposal costs: \$4,740/year; a 97% cost savings

- **Single-use:**  $\$1.56 \text{ e} \times 3,120 \text{ used/yr} = \$4,867$
- **Reusable:**  $\$10.58 \text{ e} \times 120$  (Two were purchased for each slot so that one can be in service while the other is cleaned) =  $\$1,270$  (10 yr life) =  $\$127/\text{yr}$ .  
Percentage change:  $\$4,867 - \$127 \div \$4,867 = 97\%$

Pay back occurs after:  $\$4,867 \div 12 = \$406/\text{mo} \div \text{into } \$1,270 = 3.1 \text{ months}$

**Issues:** The reusable filters work well in the Road and Bridge Department garages, and they are easily cleaned by staff with the washer. Adding a little detergent when washing takes care of any grease that may be in the filters. The shop foreman considers the time taken to wash the filters to be about equal to the time required to purchase, stock and dispose of the single-use filters.

The county already owned portable high-pressure water sprayer, so purchase was not required to implement this action. Water used by the washer is drawn from a well. Electricity used to operate the pump is not significant when compared to overall power demand.

The completely reusable air filters did not filter out enough small particulates to work for forced air units within the courthouse. However, they are being used for the courthouse air intake.



## Use reusable cups

Staff and visitors are encouraged to use reusable instead of disposable drinking cups in four ways:

- In the Road and Bridge Department, the purchasing clerk informed all of the garages that he would no longer purchase single-use cups.
- The coffee shop charges five cents extra for coffee in a disposable cup.
- The Neutral Corner coffee shop loans ceramic coffee cups to the county for meetings and washes them afterward.
- Employees who attend a reduction workshop receive a ceramic mug (donated by organizations listed below.)

### **Volume (compacted) of waste avoided: 3.4 cubic yards/year**

A case of 1,200 cups measures approximately 23" x 18" x 16". This represents shipping volume which is significantly more compact than disposal volume.

### **Weight of waste avoided: 213 lbs/year**

A case of 1,200 8-ounce polystyrene cups weighs approximately 6.72 lbs + 2.15 lbs/box = 8.87 lbs. 24 cases eliminated/year x 8.87 lbs/case = 213 lbs

### **Cost savings before avoided disposal costs: \$496 per year.**

A case of 1,200 cups costs approximately \$20.67. 24 cases x \$20.67 each = \$496/year. The 36 reusable cups were donated (cost \$45).

**Issues:** After the "Reduction Workshops" were presented to the staff by the reduction committee, cup use went down to 25 cups per week. After the coffee shop began charging five cents for a disposable cup, cup use was further reduced to approximately six cups per week. The coffee shop also purchased three dozen reusable cups for meetings. This has eliminated the need for around 2,000 cups per year that were purchased just for meetings. The Neutral Corner coffee shop went from using approximately 100 cups per week to less than seven cups per week. In addition, the Road and Bridge Department used to purchase approximately 21,600 cups per year before deciding to forgo the use of disposable cups in the garages.

Organizations that donated funds for Itasca County ceramic mugs: Minnesota Nurses Association, North Country Recycling, Recycle Minnesota Resources, AFSCME locals 580 and 1626, Norwest Bank, The Cohasset Shop, and Non-Contract Personnel.



## Reduce junk mail and duplicate mail

Staff members sent pre-printed post cards back to the senders of the unsolicited mail asking to be taken off mailing lists. Often, cards were enclosed in pre-addressed and pre-paid mailers supplied by the sender of the unsolicited mail.

This reduction action was implemented in two courthouse departments to test its effectiveness. Here is how it worked: Anyone in the office receiving junk or duplicate mail deposits it in a collection box. Periodically, a staff person takes the mail and encloses the post card in the senders pre-addressed mailer. If this is not supplied, the person cuts off the portions containing addresses of the sender and the recipient, attaches them to the card and mails it. The card reads: "To whom it may concern: In an effort to reduce our disposable waste, we request that you remove our name from your mailing list. Thank you."

### **Percent reduction of this waste stream: Over 90%**

As a result of this action, unsolicited mail has been reduced from between 75 and 100 pieces to about six per week. This is a 90-percent reduction in unsolicited mail.

### **Weight of waste avoided: 338 lbs/year**

### **Cost \$173 to purchase and mail 1,000 post cards.**

#### **Issues:**

Unsolicited mail received in the Itasca County Zoning Office and Coordinator/Human Resources Office went from an average of eight pounds per week in February to 1.5 pounds per week in May. But does this mail generally decrease from February to May anyway? No, it does not, according to information obtained from St. Paul's Main Post Office. Bulk mail is fairly constant during most of the year, but it drops off in June, July and August (after school lets out) and increases before major holidays. So it is justifiable to extrapolate this February - May data to the rest of the year.

#### **Details:**

In the coordinator's office, junk mail collected

January 25 - February 8 = 7.5 lbs/2 weeks

February 8 - March 7 = 6 lbs/2 weeks

March 7 - March 21 = 3 lbs/2 weeks

March 21 - April 20 = 3 lbs/2 weeks

April 20 - May 2 = 0.5 lbs/2 weeks

72 post cards requesting removal from junk mail lists were sent out from the coordinator's office during the period from January 25 - May 2, 1990.

In the zoning office, junk mail collected

January 16 - February 7 = 8.6 lbs/2 weeks

February 7 - March 21 = 3 lbs/2 weeks

April 3 - May 2 = 6 lbs/2 weeks (note that a 3-lb catalogue is included here)

May 2 - May 31 = 2.5 lbs/2 weeks

90 post cards requesting removal from junk mail lists were sent out from the zoning office during the period from January 16 - May 31, 1990.

The coordinator's office has 11 people, and the zoning office has six.

**Suggestion:**

Staff members came up with an idea to make it easier to reduce unsolicited mail. Senders should be required to enclose and honor a prepaid return envelope or card requesting that the receiver's name be dropped from the mailing list. If implemented: The burden of stopping unsolicited mail would include the sender, not just the receiver; specific advertisers would send mail only to those interested in it; significant resource conservation and waste abatement would result.

**In Addition:**

To help prevent its name from being sold to other mass mailing lists, the courthouse staff contacted this association (\*):

Mail Preference Service  
Direct Marketing Association  
P.O. Box 9008  
Farmingdale, NY 11735

(\*) The Mail Preference Service removes individual consumers' names from many national mailings lists at no charge. Individuals may include their name, address and zip code with their request. The Mail Preference Service cannot remove the name of an organization or company from national marketing databases.

---



## **Use reusable cloth roll towels instead of single-use paper**

Last year the courthouse used – and landfilled – a case of single-use paper towels every week. The cloth towels can be washed and reused more than 100 times. When the cloth towels wear out, they will be recycled into rags.

Courthouse uses an average of 25 cloth roll towels per week.  
Number of paper towel rolls formerly used: 504 rolls per year.

**Volume of waste avoided: 30.24 cubic yards/year**

Volume of a paper towel roll that has been used and then compacted: 0.06 cubic yard.

**Weight of waste avoided: 1,134 lbs/year**

Weight of a paper towel roll: 2.25 lbs.

**Cost increase: \$971/year**

Cost of paper towels: \$3.18 per roll (12 rolls per case).

Cost of cloth towels: \$1.90/roll + \$2.00/week charge.

**Issues:** In restrooms with usually heavy traffic, two or three cloth roll towel dispensers were installed to avoid running out of toweling during the day. The decision was made to switch to reusable towels because of a significant reduction in solid waste, even though it cost more to do so. The single-use brown paper towel rolls used by the county were the least expensive paper towel option. Local businesses that used the most expensive paper towel option, highly absorbent center C-fold towels, saved money through this action.



## Use both sides of paper

Courthouse employees are encouraged to photocopy on both sides of a page (duplex) in the following ways:

- Signs reminding people to “use both sides” are posted by photocopy machines.
- Staff members were informed during the reduction workshops that the Human Services Department photocopy machine, which can duplex automatically, is available for use by any department to make two-sided copies of documents.
- Staff in the Coordinator/Human Resources Office collect paper used on one side and make scratch pads from it. The scratch pads are available to all courthouse employees.

**Percent reduction of this waste stream: 5%**

**Volume (compacted) of waste avoided: 0.9 cubic yards/year**

212 reams of 500 sheets, 10 reams measure 17" x 10.5" x 11". This is shipping volume; because shipping containers are compact reams, disposal volume would be significantly higher.

**Weight of waste avoided: 1,060 lbs**

212 reams of 500 sheets, one ream weighs 5 lbs.

**Cost savings before avoided disposal costs: \$740 per year**

Cost per ream: approximately \$3.49; x 212 reams = \$739.88

### Details:

With comparable work loads, total copy paper purchases during the period February - April 1990 was down five percent or 53 reams from February - April 1989. Extrapolated over the year, that's 212 fewer reams of paper purchased in 1990 due primarily to photocopying on two sides of a page.

No numbers are available on the amount of waste avoided through making scratch pads out of paper used on one side, but 480 fewer Post-It™ notes will be purchased this year, probably due to the availability of these scratch pads.

### Copy paper purchased February - April 1989

February 1989:	1,031 reams
March 1989:	6 reams
April 1989:	16 reams
3-month total 1989:	1,053 reams

### Copy paper purchased February - April 1990

February 1990:	10 reams
March 1990:	990 reams
April 1990:	0 reams
3-month total 1990:	1,000 reams

The “Use both sides” sign used by the courthouse was designed by Juan Lazo of Treasure Bay Printing.



## Use fluorescent exit sign lights

There are 12 exit signs in the courthouse. Twenty-four incandescent exit sign bulbs were replaced by 12 fluorescent bulbs. The bulbs have been in place four years; none have burned out. When they begin to flicker, they will be replaced.

### Volume of waste avoided: 0.01 cu yd/yr; a 98% volume reduction

■ **Incandescent:** One bulb = 2.56 cu" x 210 bulbs used/yr = 537.6 cu"/yr

● **Fluorescent:** One bulb = 3.08 cu" x (12 fixtures ÷ 4 yr life = 3 bulbs used/yr) = 9.24 cu"/yr

One ballast = 2.03 cu" x (12 fixtures ÷ 10 yr life = 1.2 ballasts used/yr) = 2.4 cu"/yr. Note: Ten years is a conservative estimate of ballast life. Manufacturers suggest ballasts will last 15 years.

Total: 4.87 cu" + 2.4 cu" = 7.27 cu"/yr

Volume difference: Incandescent 537.6 cu"/yr - Fluorescent 7.27 cu"/yr = 530 cu" ÷ 46,656 cu"/cu yd = .01 cu yd/yr

Percentage difference:  $537.6 - 7.27 \div 537.6 = 98\%$  volume reduction

### Weight of waste avoided: 9 lbs/yr; a 92% weight reduction

■ **Incandescent:** One bulb = 0.749 oz x 210 bulbs/yr = 157.29 oz/yr

● **Fluorescent:** One bulb = 1.364 oz x 3 bulbs/yr = 4.092 oz/yr

One ballast = 7 oz x 1.2 ballasts/yr = 8.4 oz/yr

Total: 4.092 oz + 8.4 oz = 12.5 oz/yr

Weight difference: Incandescent 157.29 oz - Fluorescent 12.5 oz = 145 oz/yr ÷ 16 oz/lb = 9 lbs/yr

Percentage difference:  $157.29 \text{ oz} - 12.5 \text{ oz} \div 157.29 = 92\%$  weight reduction

### Cost savings: \$614 /year; a 92% cost savings

■ **Incandescent:** One bulb costs \$1.65 x 210 needed/yr = \$346.50/yr

Electricity use: \$1.10/1000 hours/bulb; x 24 bulbs = \$26.40 /1000 hrs or \$0.026/hr; x 8760 hrs/yr = \$231.26/yr. Total: Bulbs \$346.50 + Electricity \$231.26 = \$667.76 incandescent cost/yr.

● **Fluorescent:** One bulb costs \$1.75 x 3 needed/yr = \$5.25/yr

One conversion kit (including ballast) costs \$11.50 x 12 needed = \$138

Note: Cost comparison was conservatively based on replacing the entire kit rather than just the ballast.

\$138 ÷ 10 yr life = \$14 /yr

Electricity use; \$0.70/1000 hours/bulb and ballast; x 12 fixtures = \$8.40 /1000 hrs or \$0.0084 /hr; x 8760 hrs/yr = \$105.12 /yr.

Labor for installation: Kits are simple to install. They have an adapter that screws into existing socket; ballast mounts with adhesive. 12 fixtures x 1/2 hr (at \$20 /hr) = \$120 ÷ 10 yr life = \$12/yr for kit installation

Total: \$28 bulb cost + \$14 kit cost + \$12 installation cost = \$54 fluorescent cost/yr

Cost difference: Incandescent \$668 - Fluorescent \$54 = \$614/yr

Percentage difference:  $668 - 54 \div 668 = 92\%$  cost savings

Payback occurs after: Incandescent cost, including electricity is  $668 \div 12 \text{ months/yr} = \$57/\text{month}$ ; fluorescent cost, \$138 for kits + \$120 installation + \$105 for electricity = \$363;  $363 \div 57 = 6.4 \text{ months}$

### Additional costs: Labor and Disposal

■ **Incandescent labor:** Each fixture required service every two months or six times a year. 6 service calls x 12 fixtures x 1/3 hour/service call = 24 hours x \$20/hr labor = \$480/yr labor.

● **Fluorescent labor:** Fixtures have been in place without needing service for four years. 12 fixtures ÷ 4 yr life = average of 3 service calls/yr. 3 calls x 1/3 hr x \$20/hr = \$20/yr labor.

Note: Although a potential \$460 labor savings results from the change, this figure was not added to direct cost savings because implementation did not result in an actual reduction in staff for the facility.

**Disposal:** There was no change in contracted hauling volume for the facility due to implementation of this action alone.



## Use two-tube instead of four-tube ceiling lights

When 3M Silverlux reflectors were installed in the fluorescent ceiling fixtures of the courthouse, the building needed 816 fewer bulbs. This action reduced the number of four-foot bulbs needed from 1,732 to 916. The life of the bulbs is approximately five years. Since 816 bulbs will no longer be in place;  $816 \div 5 \text{ yrs} =$  a reduction in the purchase and maintenance of 163 bulbs/yr.

### Volume of waste avoided: .168 cu yd/yr; a 47% volume reduction

According to 3M Lighting Services (612) 487-9917, it takes 972 standard four-foot fluorescent to fill one cubic yard. Although 816 bulbs are eliminated, since they have a five-year life, 163 of those would show up as waste in a given year.  $163 \div 972 = .168 \text{ cu yd/yr}$  reduction.

Percentage difference:  $1,732 \text{ original bulbs} - 916 \text{ remaining bulbs} \div 1,732 = 47\%$  reduction in bulbs

### Weight of waste avoided: 244 lbs/yr; a 47% weight reduction

One bulb weighs 24 oz and use was decreased by 163 a year =  $3,912 \text{ oz/yr} \div 16 \text{ oz/lb} = 244 \text{ lbs/yr}$

Percent difference:  $(1,732 \times 24 \text{ oz}) - (916 \times 24 \text{ oz}) \div (1,732 \times 24 \text{ oz}) = 47\%$

Note: Half as many ballasts are now used to fulfill the same lighting need. To be conservative, however, this additional decrease in waste was not included in waste abatement figures.

### Cost savings: \$7,088/yr

Cost of all of the reflectors is \$22,411. One fixture type was changed at a time throughout the facility, streamlining the installation process. It took approximately 15 minutes per fixture at \$15/hr labor or \$3.75 per fixture.  $\$3.75 \times 628 \text{ fixtures} = \$2,355$  labor. Total installation cost is  $\$22,411 + \$2,355 = \$24,766$ ;  $\div 20 \text{ year life} = \$1,238/\text{year}$ . Reflectors are designed to last for the life of the building.

The bulbs cost \$1.39 each. One hundred and sixty-three fewer bulbs are need each year resulting in \$226 annual savings. Labor to replace one bulb is approximately five minutes at \$15/hr =  $\$1.25/\text{hr}$  each  $\times 163 \text{ bulbs/yr} = \$204/\text{yr}$ . However, this is an indirect cost savings. The action did not result in reduction in payable hours so this figure is not included in direct cost savings. Electricity: the courthouse will use 149,360 kw less;  $\times \$0.054/\text{kw} = \$8,100/\text{yr}$  electricity cost savings. Subtotal savings is  $\$204 \text{ in bulbs} + \$8,100 \text{ in elec.} = \$8,304$  every year.

Net yearly savings:  $\$1,238 - \$8,304 = \$7,088/\text{yr}$

Payback: Payback occurs after  $\$24,766 \text{ installation cost} \div \$8,304 \text{ annual savings} = 2.98$  or 3 years. Thereafter, \$8,304 is saved each year.

**Issues:** The courthouse choose to increase lighting efficiency by using reflectors to enhance performance of fewer bulbs. Another option is to install rare-earth phosphore bulbs. These bulbs produce 17 percent more light than their standard counterparts. Many overhead fixtures can be changed from four standard bulbs to two rare-earth phosphore bulbs. This is another way to decrease the number of tubes required to produce satisfactory light. This upgrade usually incorporates the use of electronic ballasts as well. The specific action that is most effective for a given facility depends on many factors and is best determined by a professional lighting consultant.

**Problem:** Through upgrading, old tubes are often replaced before they are burned out. It is wasteful to discard them when they still have useful life. Since Itasca Courthouse is using the same tubes with the reflectors, several hundred were put in storage for later use. However, storing all the used tubes was not cost-effective. So that these tubes can be reused, a give-away program was implemented. County residents many come to the courthouse and pick up some of the tubes for reuse in their home or shop fixtures. Reuse is the best option for tubes with remaining life.

Most used mercury-containing lamps from business, industry and institutions may not be placed in the trash. Even though these used fluorescents must now be managed as hazardous waste, energy efficient lighting is still the most environmentally sound choice. The need to generate 50 percent to 75 percent less electricity to run these lamps means far fewer resources are used and fewer pollutants need be released by power plants. Call the OEA for a fact sheet about fluorescent lamp disposal.

---



## Use soap and water as a degreaser

The county maintenance garage used chemical degreaser to clean engines and equipment. For other washing, a high-pressure washer was used. An experiment was made to determine if the washer could be used in place of the chemical degreaser. The washer proved to do the job as well and require less labor. As a result, the solid waste created by 65 five-gallon drums and 35 five-gallon drums is avoided. In addition, 980 gallons of chemical solvent have been replaced by soap and water.

### Volume of waste avoided: 3.8 cu yd: a 99% volume reduction

Volume for 55-gallon drum =  $\pi r^2 h = 3.14 \times (11.5")^2 \times 36 = 14,949 \text{ cu"} \times 6 \text{ drums} = 89,697 \text{ cu"} \div 46.656 \text{ cu"}/\text{cu yd} = 1.923 \text{ cu yd/yr}$

Volume for 35-gallon drum =  $3.14 \times (8.75")^2 \times 36 = 8,654.625 \text{ cu"} \times 10 \text{ drums} = 86,546.25 \text{ cu"} \div 46,656 \text{ cu"}/\text{yd} = 1.855 \text{ cu yd}$

Total volume = 1.923 cu yd + 1.855 cu yd = 3.778 cu yd

Percentage difference: The only solid waste created through the use of the washer is the soap container. The soap comes in a five gallon container and is reused by the staff. The washer is a heavy-duty, repairable unit. Its eventual disposal volume was considered insignificant when compared to solvent container waste.

### Weight of waste avoided: 558 lbs/yr: a 99% volume reduction

Weight for 55-gallon drum = 43 lbs x 6 drums = 258 lbs

Weight for 35-gallon drum = 30 lbs x 10 drums = 300 lbs.

Total weight = 258 lbs + 300 lbs = 558 lbs/yr

Percentage difference: Same information as above

### Cost savings: \$9,069/yr: a 99% cost savings

Cost of six 55-gallon drums = \$4,695/yr; Cost of ten 35-gallon drums = \$4,450/yr

Total solvent cost = \$4,695 + \$4,450 = \$9,145/yr

Cost to use washer: The high-pressure washer was already on hand and was purchased for general washing needs. The cost of the washer, approximately \$1,300, amortized over its expected 15-year life:  $\$1,300 \div 15 = \$87 / \text{yr}$ , and a percentage of its use determined for degreasing is 30%.  $\$87 \times 30\% = \$26 / \text{yr}$ . Water is drawn from a well using an electric pump. Costs for electricity and soap are estimated to be \$50 /yr.  $\$26 + \$50 = \$76 / \text{yr}$ .

Cost difference:  $\$9,145 - \$76 = \$9,069$

Percent difference:  $\$9,069 - \$76 \div \$9,145 = 99\% \text{ cost savings}$

### Additional factors:

Labor is 10 hours a week less. This represents  $10\text{hrs/wk} \times \$15/\text{hr} \times 52 \text{ wk/yr} = \$7,860$  potential savings. However, staff time was taken up by other activities and there were no actual reductions in staff.





## Reuse heavyweight equipment air filters

Over 350 air filters per year were used by road graders and large trucks. The maintenance department found it could have these filters professionally cleaned so that they could be reused three or four more times.

### Volume of waste avoided: 3 cu yd; a 75% volume reduction

One cylindrical filter is 15" height x 12" diameter = 540 cu" x 350/year = 189,000 cu". Filters are reused three times. In other words, one filter is used four times instead of once. One-quarter of the original waste volume is now produced.  $189,000 \text{ cu}'' \div 4 = 47,250 \text{ cu}''$  of waste is now produced.  $189,000 \text{ cu}'' - 47,250 \text{ cu}'' = 141,750 \text{ cu}'' \div 46,656 \text{ cu}''/\text{cu yd} = 3 \text{ cu yd}$  reduction. Percentage difference:  $189,000 - 47,250 \div 189,000 = 75\%$  reduction

### Weight of waste avoided: 2,625 lbs/yr; a 75% weight reduction

One filter weighs 10 pounds, x 350 used/yr = 3,500 lbs/yr,  $\div 4 = 875 \text{ lbs/yr}$  current generation;  $3,500 \text{ lb} - 875 \text{ lb} = 2,625 \text{ lb/}$  year reduction. Percentage difference:  $3,500 \text{ lb} - 875 \text{ lb} \div 3,500 \text{ lb} = 75\%$  reduction

### Cost savings: \$7,312/yr; a 52% cost savings

New filters cost \$40 each. It costs \$12 to recondition one.  $350 \text{ filters/yr} \times \$40 = \$14,000/\text{yr}$ . With reuse, 88 filters are purchased/yr x \$40 ea = \$3,520 and are reconditioned three times @ \$12 ea =  $88 \times 3 = 264 \text{ filters} \times \$12 = \$3,168$ .  $\$3,520$  initial purchase + \$3,168 reconditioning cost = \$6,688. Cost difference:  $\$14,000 - \$6,688 = \$7,312/\text{yr}$  savings. Percentage difference:  $\$14,000 - \$6,688 \div \$14,000 = 52\%$  cost savings

Issues: Itasca County uses NAPA, a national parts supplier, to recondition its filters. Olmsted County has had very good results from Filter Rite of St. Clair, Minnesota, 507-245-3097.



## Limit paint use

When road equipment was rebuilt by maintenance personnel, it was thoroughly cleaned and repainted before being put back into service. The equipment is still cleaned, but instead of being repainted, spot-painting is done. Although the equipment does not look "new" when it emerges from the shop, the areas in need of attention are repaired. This change in procedure prevents the use of 275 gallons of paint per year.

### Volume of waste avoided: 1.5 cu yds; a 92% volume reduction

One can measures 3.28" in radius and 7.5" in height.  $V = \pi r^2 h$ ;  $3.14 \times 10.76 \times 7.5 = 253.4 \text{ cu}''$ ; Due to this action, use of 300 gallons of paint is decreased to 25 gallons of paint/year.  $275 \text{ gallon reduction} \times 253.4 \text{ cu}'' = 69,674 \text{ cu}'' \div 46,656 \text{ cu}''/\text{cu yd} = 1.493 \text{ cu yds}$ . Percent difference:  $300 - 25 \div 300 = 92\%$  reduction

### Weight of waste avoided: 424 lbs; a 92% weight reduction

One can with a typical amount of residual paint weighs 700 grams; x 275 cans/yr = 192,500 gm/yr;  $\div 453.6 \text{ gm/lb} = 424 \text{ lbs/yr}$ . Percent difference:  $(300 \text{ cans} \times 700 \text{ gm}) - (25 \text{ cans} \times 700 \text{ gm}) \div (300 \text{ cans} \times 700 \text{ gm}) = 92\%$  weight reduction.

### Cost savings: \$16,500/year; a 92% cost reduction

The cost of one gallon of equipment paint is \$60. As a result of this action, 275 fewer gallons of paint are used.  $\$60 \times 275 = \$16,500$  savings/yr. Percent difference:  $(300 \times \$60) - (25 \times \$60) \div (300 \times \$60) = 92\%$  reduction



## **Policy: Use long-life, repairable products**

In both the courthouse and the Road and Bridge Department it is policy to purchase well-made, long-lasting tools and equipment and to repair or rebuild as needed. This policy results in significant money and waste savings for the county.

For example, several years ago chainsaws in the Road and Bridge Department were of many various makes and models. Not only did quality vary, but when a saw needed repair, either special parts had to be purchased or the saw was thrown out. Now the Road and Bridge Department purchases only one high-quality make and model of chainsaw. Using equipment with interchangeable parts saves time and money and prevents waste.

### **Examples of equipment with rebuildable parts:**

Heavy equipment and trucks are required to have rebuildable parts.

- Identified examples include such things as: diesel fuel injectors, water pumps, starters, generators, fuel pumps and hydraulic rams for dump trucks and other equipment.

### **Examples of equipment purchased in standard brands:**

- Chainsaws - one brand and one model.
- Brush saws - one brand and one model.
- Pneumatic tools - one brand.
- Tools with long warranties are given preference.

Note that current competitive bidding requirements mean that standard brands cannot be established for vehicles and equipment costing \$15,000 or more.

### **Purchase cleaners and other products in reusable five-gallon pails:**

Purchase of concentrated cleaners and other products in reusable five-gallon pails is another county policy. (The pails are given away for reuse). Rather than using pre-mixed cleaners in aerosol cans, employees dilute concentrates for use in refillable pump spray bottles.

### **Rebuild office furniture:**

Office chairs are rebuilt and reupholstered, file cabinets and desks are reconditioned and repainted.

### **Examples of reduction ideas that were not workable**

- Pop machine with reusable/refillable bottles.  
No longer available.
- Cloth rags in road and bridge department garages.  
Wastewater treatment system doesn't handle grease and oil well.
- Make scratch pads out of computer paper used on one side.  
Too much computer paper. Recycling made more sense in this case.
- Use bulk spray paint instead of throw-away cans for marking timber.  
Washing out containers and using more paint or ink may limit waste reduced.  
Inconvenience, low acceptance by foresters.

The committee continues to identify and implement source reduction actions. For example, in an effort to increase tire life, all the Road and Bridge Department trucks and equipment now sport stickers reminding drivers to check tire pressure.

## **Conclusions**

**Reduction can accomplish significant waste abatement.**

Although many of the reduction methods employed were simple (e.g., encouraging the use of reusable instead of disposable cups), when undertaken seriously they make a sizable dent in the waste stream.

Three factors were vital in the success of this project. They are:

1. Those people who work in a facility know or can best determine the reduction methods most appropriate for that facility. For example, the person facilitating this project from the Office of Environmental Assistance had never heard of washable, reusable air filters.
2. A team approach provides an opportunity to divide work and maintain motivation. In-house volunteerism makes the project work. One person cannot do it alone.
3. Education of the entire staff in a facility on the definition of reduction, the importance of each person's cooperation and reduction going on in each department is crucial to the project's success. Staff members who were not on the committee seemed particularly receptive because the project was supported by upper management but actually taught and implemented by peers.

As a result of county government reduction and recycling efforts, container services were decreased from four to two dumpsters per month. This is a 50-percent reduction in contracted hauling volume that cut garbage hauling expense by \$700 per year.

**The total savings for the waste management program is approximately \$46,900 a year.**

## Commonly used formulas

### Volume measurements

volume of rectangle = length x height x width  
volume of cylinder =  $\pi$  x radius squared x height  
 $\pi = 3.14$

### Volume conversions

1 gram = 1 milliliter of distilled water (at 36° F) = 1 cubic centimeter  
1 cubic centimeter = .061 cubic inch  
1 cubic inch = 16.387 cubic centimeters  
2 pints = 1 quart = 32 fluid ounces = .9464 liter  
4 quarts = 1 gallon = 128 fluid ounces = 231 cubic inches  
1 cubic yard = 46,656 cubic inches

### Weight conversions

10 grams = 0.3527 ounce  
1 kilogram = 2.2046 pounds  
16 ounces = 1 pound

### Comparisons

Ratio of the waste of one product to another in volume, weight or cost is:  
high-waste product ÷ low-waste product = ratio

Percentage of the waste of one product to another in volume, weight or cost is:  
high-waste product – low-waste product ÷ high-waste product = percent

### MSW volume to weight estimates

350 pounds of uncompacted household waste per cubic yard  
620 pounds of waste per cubic yard in a refuse hauling truck  
1 ton = 3.23 cubic yards in a refuse hauling truck

### Electricity

For calculating changes in electricity consumption for lighting, see Appendix B.

## Compact fluorescent savings

Check the label to make sure that the compact fluorescent gives the same amount of light as the incandescent you want to replace.

### Calculate your own savings

1. What is the wattage of the lamp "light bulb" (including ballast draw for the compact fluorescent)?

2. What is the rated life of the lamp?

3. How many incandescent lamps will have to be installed to produce light for as many hours as the single compact fluorescent lamp?

Divide the life of the compact fluorescent option by the life of the incandescent option and place answer in blank at right. Round off to the nearest whole number.

4. How much electricity does each option consume over the life of the compact fluorescent lamp?

Multiply #1 x #2 x #3 to get watt-hours, and divide the result by 1,000 to convert to kilowatt-hours.

5. What do you pay for electricity?

National average is \$.08/kW-h for residences and \$.06/kW-h for commercial facilities.

6. How much will it cost you to operate each option over the life of the compact fluorescent lamp?

Multiply #4 x #5

7. What will it cost you to purchase the lamps for each option over the life of the compact fluorescent lamp?

Multiply cost per lamp x #3

8. What will it cost you to buy and operate each option over the life of the compact fluorescent lamp?

Add #6 + #7

How much money will you save by using a single compact fluorescent lamp? (Subtract #8 right column from #8 left column to get your savings.)

Incandescent	Compact Fluorescent
Wattage: _____	Wattage: _____
Life: _____	Life: _____
Lamp cost: _____	Lamp cost: _____
_____ watts	_____ watts
_____ hours	_____ hours
_____ lamp	_____ lamp
_____ kW-h	_____ kW-h
\$ _____ kW-h	\$ _____ kW-h
\$ _____	\$ _____
\$ _____	\$ _____
\$ _____	\$ _____
<b>Savings *</b>	
\$ _____	

\* This figure represents the money saved on your electric bill and in purchase of lamps. Greater savings will be seen in most commercial facilities, where labor to change light bulbs is costly and the reduced heat gain from cooler-operating, more efficient lighting also translates into lower air-conditioning bills. (Reformatted by OEA with permission from Rising Sun Enterprises, Inc. 303-927-8051)

## ■ Appendix C

# Waste composition audits and surveys

### What is a waste composition audit?

A waste audit is a quantitative or measurable assessment of the amounts of waste created by different discarded products. Typically, a day's waste is collected and sorted by hand into different product types, such as white and colored paper, aluminum and steel cans. Different types are weighed to determine how much of each is generated as waste. This gives a quantitative "snapshot" of the waste composition. The more frequently the assessments are made, the more comprehensive the information.

Waste audits don't need to be complicated endeavors and, with proper safety training, can be accomplished by the organization's own employees. Puncture-resistant gloves, protective shoes and long-sleeved shirts are necessary. Hard hats with protective face shields are used in some circumstances. Consultants are sometimes used as team leaders or to conduct the entire process.

The goal of a waste audit is to establish quantities of individual product types in a waste stream. When results are contrasted with measurements obtained from another audit done at a later date, changes in waste composition can be shown. Audits can be useful for identifying source reduction, materials exchange, recycling and composting opportunities.

### What is a waste composition survey?

A waste survey is a qualitative or estimated assessment of the amounts of waste created by different discarded products. Limited quantitative measurement takes place. Typically, a day's waste is collected and spread on a large plastic sheet. Products are identified and estimates as to the percentage they occupy in the waste stream are made. At a minimum, team members who handle the trash should wear puncture-resistant gloves.

The goal of a waste survey is to familiarize employees with products that are discarded. Like a waste audit, a waste survey is useful for targeting products for source reduction, exchange, recycling and composting.

### Are there possibilities for materials exchange?

It is important to evaluate waste in terms of its potential use by other people. What is waste for one company may be a resource for another, and waste assessments can identify opportunities.

Limitations to waste assessments: In addition to products leaving an organization as waste, products may leave by mail or by shipping. This is one reason that employees suggest actions to reduce waste based on the products that they use, not just what they throw out. This is important because mailing and shipping less wasteful products, products with less packaging for example, conserves resources, decreases costs for the organization and decreases the amount of waste that must be managed by the receiver.

Many products may not show up in the waste stream on the days waste assessments take place but may be significant on an annual basis. Ideas to reduce waste usually come

from people as they work with products they use. However, seeing the waste the products create often provides motivation to find less wasteful alternatives.

Assessing the waste that leaves a facility is an excellent educational and targeting tool. However, using waste assessments to measure the success of a source reduction program in an organization can be more expensive and less precise than relying on purchasing records.

Examining purchasing records for targeted products shows how much of each product is used. **Waste generation is often more readily based upon what comes into a facility than or what goes out.** By measuring the weight and volume of a targeted product as it is discarded, the amount of waste generated through the use of that product over time can be accurately established.

The following list can be used during a waste assessment. It lists common materials found in waste. Other products should be added as they are found. The list is useful in identifying waste management opportunities. Valuable information may also come through interviewing personnel about the waste they create.

# Waste checklist

Date: \_\_\_\_\_

Location: \_\_\_\_\_

Personnel Present: \_\_\_\_\_

Product	Weight or volume percent present
White paper	
photocopy paper	_____
envelopes	_____
computer paper	_____
lined paper	_____
letterhead	_____
fax paper	_____
carbonless forms	_____
card stock	_____
other paper	_____
_____	_____
_____	_____
Colored paper	
pastel paper	_____
dark or fluorescent paper	_____
glossy brochures	_____
glossy bulk mail	_____
magazines/catalogs	_____
carbon paper	_____
_____	_____
_____	_____



**Product**

**Weight or volume percent present**

Manila or kraft paper

envelopes

file folders

bags

\_\_\_\_\_

\_\_\_\_\_

Newsprint

Cardboard

corrugated

boxboard

\_\_\_\_\_

\_\_\_\_\_

Napkins/paper towels

plates

cups

flatware

Aluminum

cans

foil

building materials

\_\_\_\_\_

\_\_\_\_\_

Steel

cans

under one gallon

between one and ten gallons

between ten and sixty gallons

bands for strapping

building materials

\_\_\_\_\_

\_\_\_\_\_

**Product**

**Weight or volume percent present**

Glass

- clear
- brown
- green
- blue
- drinking and window glass
- \_\_\_\_\_

Plastics

- #1's - PETE (polyethylene terephthalate)  
bottles
- #2's - HDPE (high-density polyethylene)  
unpigmented bottles  
colored bottles
- #3's - V (polyvinyl chloride)
- #4's - LDPE (low-density polyethylene)  
film
- #5's - PP (polypropylene)
- #6's - PS (polystyrene)  
foam  
rigid
- #7's - Other or unknown
- \_\_\_\_\_
- \_\_\_\_\_

Food waste

Yard waste

Other products

- \_\_\_\_\_
- \_\_\_\_\_
- \_\_\_\_\_
- \_\_\_\_\_
- \_\_\_\_\_

## Benefits of Funding Community Source Reduction Programs

Funding is required to implement regional source reduction programs. Several levels of financial commitment exist.

- ▼ The least expensive way to promote source reduction is through public domain educational videos and written materials. Staff members distribute these upon request, at public meetings or through mailings.
- ▼ Public speaking, technical assistance for case studies or paid advertising can achieve additional promotion of source reduction.
- ▼ Funding of promotion can be separate from funding of measurement of source reduction.

At a minimum, educational materials should be available to the public. This helps raise awareness and distribute ideas that, if implemented, will reduce waste. Even distribution of materials requires funding. With limited budgets, government entities hesitate at

## ■ Appendix D

dedicating funds for anything beyond duplication and mailing of educational materials until they know the programs will likely result in success. Measuring success, as described in the Product, Facility and Regional Measurement sections of this manual, helps justify expenditures.

### What are the potential benefits for a community that implements a source reduction program?

There may be a significant community economic benefits to implementing a reduction program. A conservative estimate of the average statewide cost of collecting, handling, processing and disposing of our MSW is at least \$120 per ton. Evidence from the OEA's research indicates that an average business or home can reduce its MSW by at least 10 percent through source reduction. Projected cost benefits follow.

#### For example:

Olmsted County (Minn.) managed approximately 75,000 tons of mixed MSW in fiscal year 1991 (1991 SCORE Report). This figure does not include recycled tonnage. At \$120 a ton, this represents a \$9 million yearly cost to county citizens and businesses to pay for management of their mixed MSW.

There are fixed and non-fixed costs for managing solid waste. Fixed costs are for equipment, operation of facilities and payment of capital bonds. These costs are paid independent of amounts of MSW handled. However, not all costs are fixed. As amounts of

<sup>1</sup>OEA estimate based on an informal survey of haulers and municipalities and does not include additional cost for monitoring, financial assurance for closure or clean-up costs.

<sup>2</sup>According to Resource Recycling, Oct. 92; The Region's Agenda, Oct. 92; and Seattle, WA 1991 Recycling Potential Assessment, the cost of a typical curbside collection program is under \$71 per ton. It is less for commercial and more for rural programs.

<sup>4</sup>This is based on state-average cost per ton. A more accurate cost figure is possible by using cost data for individual counties.

solid waste decrease: (1) existing compost and incineration facilities can process waste from a larger region; (2) landfills will have longer lives, the need for new construction can be postponed; (3) fuel and labor costs decrease because haulers can service more accounts before tipping; (4) fewer round trips are required on roadways. By maximizing the size of the region served by a MSW facility, more people are available to pay for the facility. This decreases costs per person.

According to information from waste haulers, non-fixed costs represent between 10 percent and 30 percent of the total cost of managing waste. Non-fixed costs represent between \$900,000 and \$2,700,000 a year for Olmsted County. Conservatively, a 10-percent decrease in amounts of solid waste would result in a savings of between \$90,000 and \$270,000 in non-fixed costs. (Additional savings come from extending the life of area landfills, which will be expensive to replace.)

Though changes in amounts of solid waste can be quantified, other savings due to source reduction may not be. Case studies document waste and cost savings of individual organizations. There will be some savings from decreased disposal costs. However, the majority of savings result from more efficient products and behavior. These savings are in addition to the savings in non-fixed costs. Reducing waste frees revenue for other needs. However, an organization's savings remain largely unknown to local or state government.

Most counties spend virtually nothing on source reduction. Olmsted County is an exception. It has one full-time source reduction coordinator. The cost of the county's entire program is under \$35,000 per year.

Potential barrier: Virtually all government programs, including recycling, cost money up front and are done for long-term public benefit.

The costs of public education, for example, are not returned to school district budgets until students become taxpayers. Source reduction has the potential to be cost-effective relatively quickly. Be aware of the temptation to evaluate source reduction programs by harsher fiscal criteria than those used to evaluate other community programs.

### **With cost savings so apparent through source reduction, why isn't more staff made available to implement programs?**

Economic realities often limit a community's best intentions. Savings from source reduction go to county citizens and businesses, not into the county budget. With no increase in funding, counties are being asked to spend additional resources for another program. In addition, some counties receive funds from the tipping fee charged at waste management facilities. Funds will decrease as less waste is dumped. (To specify this amount, calculate what a 10-percent decrease in tipping revenue means to a specific county's budget.)

Another barrier may be a preconception that source reduction interferes with recycling. OEA case studies show that less than 10 percent of the products targeted for source reduction were made from recyclable materials. Many of these recyclable materials were plastics with poor markets, not locally recyclable. This indicates that the conflict between reduction and recycling may be overstated.

### **How can programs be funded?**

Limited funding for source reduction already exists. Minnesota places a 6.5-percent sales tax on MSW collection and disposal, which goes into the state general fund. A majority of the funds received from this tax

goes to counties for the purpose of reducing and recycling solid waste. Much of the revenue for Olmsted County's reduction coordinator comes from this funding. Other counties may be able to do the same.

### **What does the state have to gain?**

Minnesotans generate over four million tons of MSW each year. Of that, 1.5 million tons is recycled, leaving 2.5 million tons for management. Collecting and processing this waste is expensive. At \$120 per ton, this represents a \$300-million yearly expense. Non-fixed cost estimates (those costs that are independent of waste management facilities and equipment) represent between 10 percent and 30 percent of this figure, or between \$30 million and \$90 million a year. A ten-percent reduction in waste generation would result in saving between \$3 million and \$9 million each year. While reaching the goal, the savings from source reduction progress accrue yearly.

### **Are other significant savings apparent through source reduction?**

While reducing waste decreases non-fixed costs of waste management, these savings do not include the substantial cost benefits businesses experience through increased efficiency. Actual disposal cost savings are small when compared to cost savings from using more efficient products and services. These cost savings increase the economic viability and the competitive edge of the organization.

In addition, environmental and economic benefits of source reduction may not show up on the state's balance sheet but benefit the populace as a whole. Source reduction provides for sound investment. It promotes sustainable environmental and economic development.

For further information on source reduction in Minnesota:



520 Lafayette Rd. N., Second Floor  
Saint Paul, Minnesota 55155-4100  
phone 612-296-3417 (\*)  
fax 612-215-0246 (\*)  
800-657-3843 Minnesota toll-free  
<http://www.moea.state.mn.us>

(\*) Beginning in July 1998, a new area code (651) will take effect for the OEA. After January 1999, calls made to the (612) area code will no longer reach the OEA. Please make note of this change.

# Source Reduction

Source reduction is the first priority among waste management options because it has virtually no negative effect the environment, conserves energy and resources, and does not require new facilities.

Source reduction can be defined as any activity that prevents waste at its source. It includes:

- Reducing the amount or the toxicity of material used to do anything.
- Reusing an item in its original form.
- Using repairable, refillable, durable products that last longer before they wear out.

## Comparing reducing, recycling

Recycling uses waste in place of virgin material to make new products. Recycling is

### Example 1

*Reduction prevents waste: Bag groceries in reusable cloth bags.*

*Recycling uses waste: Bag groceries in a paper bag and recycle it for remanufacture into a new product.*

### Example 2

*Reduction prevents waste: Purchase milk in a returnable container and return it for reuse as a bottle.*

*Recycling uses waste: Take a single-use bottle to a recycling center for remanufacture into a new bottle.*

a familiar concept to most people, and it usually overshadows reduction when the two are promoted together. While both waste reduction methods have the same goals of environmental protection and resource conservation, in practice they differ.

## How to reduce your waste

- **Reduce material used to do any task.**  
Buy in bulk or in economy-size packages. Buy concentrated liquids; mix them in reusable containers. Use double-sided photocopying. Use efficient-flow valves to reduce liquid use. Buy products with minimal packaging.
- **Reuse item in original form again and again.**  
Reuse packing containers and bags. Refill printer toner cartridges. Exchange waste with others – your waste may be useful to someone else.
- **Buy reusable instead of single-use products.**  
Use reusable instead of single-use cups and plates. Use cloth instead of paper towels, napkins and diapers. Use rechargeable batteries. Use refillable instead of single-use bottles.
- **Buy for durability and repairability.**  
Select products with long warranties. Buy products with interchangeable parts. Use refillable ink pens and dispensers. Use compact fluorescent instead of incandescent lights.



Minnesota  
Office of  
Environmental  
Assistance

520 Lafayette Rd. N.  
Second Floor  
St. Paul, MN  
55155-4100

612-296-3417  
Toll Free:  
800-657-3843

### ■ Reduce toxicity of process or product.

Use non-toxic cleaners.

Use non-toxic varnishes and paints.

Use propylene glycol instead of ethylene glycol antifreeze.

Use hand-operated instead of motorized can-openers, pencil-sharpeners and tools such as screwdrivers.

## Reduction saves money

Reduction practices often save money both directly and indirectly. For example, by using compact fluorescent light bulbs, a business can reduce maintenance, trash and energy costs.

Sometimes, projecting long-term costs will determine whether money saved through reduction will offset an initial investment. For example, a school cafeteria considers whether to use reusable trays, which require washing, instead of single-use dishes. The long-term cost of the dishwasher and labor may turn out to be less than the cost of purchasing and disposing of single-use dishes over the lifetime of the reusable dishes and dishwasher.

## Measuring the results

Source reduction can be readily measured on a product-by-product basis. For each change that is made, costs as well as weight and volume of waste can be determined. If hauling truck scales are used, it is possible to measure the change in an entire facility's waste over time. Measuring the changes in a community's waste is possible, but expensive. However, too much emphasis on measuring may divert money from the actual reduction program.

There are other ways to assess the effects of reduction. Surveys can help determine how well people have incorporated source reduction practices into their daily routines. This information may help predict the success of a community source reduction program.

## Source reduction pilot project

In 1989, Itasca County was selected for Minnesota's first source reduction pilot project. The Minnesota Office of Environmental Assistance (OEA) worked with county government, businesses and institutions to try reduction methods and analyze the results.

The evaluation shows how much waste can be eliminated through a number of specific reduction practices. The actions that government and businesses in Itasca County undertook resulted in significant cost savings and reduction of waste. These case studies are available from the OEA.

Reduction committees have recognized that there is no such thing as throwing an item "away." It goes somewhere. It may be "single-use," but it is not "disposable." It may be moved, compacted, buried or changed to ash and vapor, but something still must be done with the resulting waste. Realizing this has motivated the reduction committees to find solutions by reducing waste at its source.

Reduction does not require new facilities, but it does require forethought – buying durable, repairable products and reusable instead of single-use products; reusing an item over and over again; reducing the amount or toxicity of material used to produce and package an item, or simply reducing the material used to do anything. All reduce waste at its source.

## For more information

For technical assistance on source reduction, contact Kenneth Brown at 612-215-0241, or 800-657-3843 toll-free. For printed information, contact the OEA's Education Clearinghouse, 612-215-0232 or toll-free 800-877-6300.

## Popular Ways for Businesses to Reduce Waste

Source reduction prevents waste at its source. When you do any of the following, you reduce waste:

- Reduce the material used to do any task.
- Reduce the toxicity of the material used to do any task.
- When safe, reuse a single-use product over and over again.
- Purchase reusable instead of single-use products.
- Use concentrates; buy in bulk when practical.
- Use refillable, repairable products.
- Participate in a waste exchange.

Here are 14 increasingly popular actions that are reducing waste and saving money for many institutions and businesses. The list of vendors is provided to aid you in your information-gathering efforts only and does not constitute endorsement by the Minnesota Office of Environmental Assistance (OEA).

### ■ Use solar-powered calculators and battery rechargers.

Solar-powered calculators eliminate the need for batteries. Solar-powered rechargers use sunlight, not generated electricity, to recharge batteries.

### ■ Use refillable pens, pencils and tape dispensers.

Americans throw out 1.6 billion single-use pens each year. Refillable pens and mechanical pencils often don't cost more over the long term, and their use prevents unnecessary waste.

If your company must use wooden pencils, hand-powered sharpeners are often as fast as electric sharpeners. Refillable tape dispensers eliminate the need for single-use ones.

### ■ Use reusable calendars.

Hard-surfaced, perpetual calendars can be wiped clean and reused year after year. By using water-based markers, you can avoid petroleum-based markers.

### ■ Use two-way envelopes.

If your office conducts a large amount of regular correspondence with other facilities, use two-way envelopes. These envelopes can be sent back and forth dozens of times before being recycled.

For billing, use convenient send-and-return envelopes. They look like standard envelopes, but after a slight twist they can be used again. For more information on send-and-return envelopes contact Tension Envelope at 800-966-5452. **Note:** If your envelopes need windows, order them without plastic.

### ■ Reuse file folders and binders.

Applying new labels extends the usefulness of file folders and binders. Unused mailing labels work, but if you plan to buy labels, get those with gum instead of adhesive. Gum labels don't contaminate recyclable paper.

### ■ Refurbish office equipment.

Many agencies and business are reusing office furniture instead of buying new furniture. Sometimes in-house maintenance people recondition the furniture; sometimes businesses that specialize in office furniture



Minnesota  
Office of  
Environmental  
Assistance

520 Lafayette Rd. N.  
Second Floor  
St. Paul, MN  
55155-4100

612-296-3417  
Toll Free:  
800-657-3843



repair do the job. Look in the Yellow Pages under "Furniture - Repair and Refinishing - Office." Computers are also repairable. Businesses that recondition and sell them are now flourishing.

#### ■ Use bulletin boards.

Rather than routing memos, post information on bulletin boards or use computer networks for electronic mail.

#### ■ Change to cloth towel dispensers.

Changing to modern cotton towel dispensers in place of paper towels reduces solid waste, makes for tidier restrooms and can save money.

**For more information:** Look in the Yellow Pages under "Uniform Supply Services."

#### ■ Reuse printer toner and ribbon cartridges.

Remanufactured cartridges can cut these costs 50 percent yearly. Some remanufacturers use higher-quality replacement parts than those that are originally installed.

**For more information:** Look in the Yellow Pages under "Computer Supplies."

Questions to ask your vendor are:

- Do you refill or remanufacture cartridges?
- If you remanufacture, what parts do you replace?
- What do you do with the old parts and toner?
- Do you service both ribbon and toner cartridges or do you send one out?
- How long have you been in business?
- What does your guarantee cover?

#### ■ Change to fluorescent exit sign bulbs.

One fluorescent exit sign bulb outlives six to eight incandescent bulbs, creates less waste and requires dramatically less labor to maintain. In addition, fluorescent bulbs use a fourth of the electricity to produce the same amount of light. Both straight tube (mini-bi pen) and U-tube (PL) are available in convenient exit sign conversion kits. This measure

can result in significant cost savings and garbage reduction.

**For more information:** Look in the Yellow Pages under "Lighting Distributors." Suppliers that have contacted the OEA are:

Energy Saving Devices, St. Paul, 612-222-0849

Hetherington Industries, 215-949-3888

Progressive Technology in Lighting, 616-396-2556

Rising Sun, Inc., 303-927-8051

Compact fluorescent indoor and flood lights can also give excellent source reduction and cost savings. Use caution, however; some are sold with the ballast and bulb glued together as one unit. When the bulb burns out the entire assembly must be thrown out. To avoid this waste and expense, make sure the bulbs can be replaced.

Stay with tested, well-made, name-brand products. Inferior compact fluorescent lights with poor performance are on now the market.

**Note:** The Legislature amended Minn. Stat. 1990, Sect. 16B.126, in May 1991 to require fluorescent exit sign bulbs in all internally lit exit signs by Jan. 1, 1994.

#### ■ Convert four-bulb fluorescent fixtures to high-efficiency two-bulb fixtures.

By replacing standard four tube-two ballast fixtures with rare-earth phosphor two-tube-one-electronic-ballast retrofits, Cable News Network reduced lighting costs by 63 percent. The modern tube produces 17 percent more light than the old. The new ballast is silent, eliminates any perceptible flicker and uses 75 percent less power. In addition, only half the waste is produced to fulfill the same lighting need.

**Note:** Old but still functional bulbs can be given away to citizens for reuse in their shops or garages. Itasca County Courthouse has such a reuse program for its lighting upgrade project (218-626-2857).

**For more information:** Look in the Yellow Pages under "Lighting Systems." Retrofit companies that have contacted the OEA are:

3M Lighting Services, St. Paul, 612-487-9917

Rising Sun, Inc., 303-927-8051

■ **Use reusable cafeteria dishware.**

Reusable dishes are often cost-effective, even when dishwasher installation expense is included. A decrease in refuse-hauling cost can accompany the change because it can result in such a notable reduction of waste.

■ **Use least-waste milk containers.**

Cardboard milk cartons are made of plastic coated paperboard and are not readily recyclable. In a landfill, they take up approximately 10 percent of their original volume and take decades to decompose.

If a dishwasher is in place to wash the reusable cups that go with serving milk from bulk dispensers, the change to bulk milk reduces a major component of cafeteria waste. It can also save money and teach reuse.

If a change to bulk milk is not possible, a change to reusable milk containers is effective. Reusable gallon and half-gallon milk containers are available in much of Minnesota, and pilot programs are under way to test reusable eight-ounce (single-serving) containers.

If bulk or reusable containers are not an option, plastic pouches are next best. Plastic pouches take up 1/25 the volume of paper cartons in a landfill and are made of LDPE, a relatively recyclable plastic.

**For more information:** Contact milk distributors in your area who carry these products. The OEA was contacted by the following dairies.

Kemp's Dairy, 800-356-1326, has information on bulk and pouch milk.

Schroeder Milk, 612-487-1471, has information on

reusable half-gallon and gallon containers.

Sauk Centre Cooperative Creamery, 612-352-6513, has information on reusable eight-ounce containers.

■ **Use reusable forced-air filters.**

By installing completely reusable aluminum forced-air filters in Itasca County garages, the county saves approximately \$4,000 and eliminates more than 53 cubic yards of waste each year. Installing partially reusable forced-air filters in the county courthouse saves approximately \$800 and eliminates 26 cubic yards of waste each year.

**For more information:** Reusable filter suppliers that have contacted the OEA are:

Scan Air Filter, Inc., 612-825-2020

Twin City Filter Service, 612-722-9391

■ **Eliminate single-use cups.**

Many offices and businesses have eliminated single-use cups in favor of employees using reusable cups. Progressive coffee shops are charging five cents less to customers who bring reusable cups.

■ **Reuse single-sided paper.**

Use a box next to the photocopier for stacking single-sided photocopy paper "waste." With the simple use of a paper cutter and binding glue, this waste paper can be made into note pads. One company that sells binding glue is Merritt Products Co., 216-352-0697. The glue is not absolutely necessary. Employees can stack quarter sheets beside their phones for note paper.

**Note:** Print on both sides of a sheet of paper when appropriate.

■ **Eliminate aerosol spray cans.**

Significant cost savings and waste reduction can result when businesses use concentrates and mix them in reusable pump-spray bottles. The Sawmill Inn, Grand Rapids, eliminated aerosol cans in favor

of refillable pump-sprays and found the change reduced waste and saved money.

## **Spread the word**

As your organization implements these or any other source reduction activities, please contact the OEA so that the information can be made available to others.

## **For more information**

For further information on source reduction, call the Office of Environmental Assistance Clearinghouse at 612-215-0232, or 800-877-6300.

For technical assistance on source reduction for businesses or to give information on how your source reduction program is working, call Kenneth Brown, Minnesota Office of Environmental Assistance, 612-215-0241 or 800-657-3843 toll-free.

## Preventing waste: A source reduction checklist

Source reduction is an activity that **prevents** waste at its source. It is first among waste management options because it has virtually no negative effect on the environment, it conserves energy and resources, and it does not require new facilities.

People often want to know which products are best for the environment so they can make environmentally friendly purchases. But determining which products are most environmentally friendly is difficult. Such a calculation must take into account the toxic materials and resources used and the waste produced through:

- Gathering and refining raw materials.
- Manufacturing the products, including construction of the factory where the products are made and the energy needed to make the products.
- Transporting raw materials and finished products.
- The consumers' use and disposal of the products.

An evaluation this comprehensive is beyond the capabilities of most organizations. However, people can focus on one element: the waste created through their own use and disposal of products. Choosing to produce less waste reduces the need for facilities such as landfills to manage the garbage. Having fewer or smaller facilities means less impact on the environment. To reduce your waste:

### Choose less packaging

- Buy refillable bottles of milk, soft drinks, beer and other beverages.
- Look for products with minimal packaging. Buy the ones with the fewest layers.
- Bring your own cloth or paper bag when shopping. Reuse plastic bags when buying produce or bulk items.
- Use reusable storage containers instead of single-use plastic bags.
- Buy items in bulk to avoid extra packaging and expense. Products available include nails, screws, bolts, cereals, pasta, spices, candy and dried fruit.

- Avoid individually wrapped items. Buy economy-size packages of products you use a lot.
- Make a shopping list of items you really need and stick to it. Impulse buying may add to waste.

### Use products that last a long time before they wear out

- Products that last a long time create less waste, and you will often save money in the long run. Buy well made products that are easy to repair and have long warranties.
- Use reusable cloth napkins, diapers and towels.
- Take a reusable coffee mug to work.
- Use silverware and heavy-duty, reusable plastic plates and glasses for parties and picnics.
- Ask for high-mileage tires. They usually cost less per mile traveled. Keep them filled to the proper air pressure for maximum wear.
- Buy compact fluorescent lights instead of incandescent ones.
- Clean, maintain and repair your tools, appliances, vehicles, shoes and clothing.
- Check consumer publications for lists of durable items.

### Borrow and rent

- Rent or borrow such things as power and hand tools, landscaping equipment, specialized tools, audiovisual equipment, office furniture, medical equipment, baby furniture, ladders and moving equipment.
- Buy and share equipment such as rototillers or snowblowers with a group of neighbors or friends.



Minnesota  
Office of  
Environmental  
Assistance

520 Lafayette Rd. N.  
Second Floor  
St. Paul, MN  
55155-4100

612-296-3417  
Toll Free:  
800-657-3843

## Reuse it

- Use glass jars for storing foods, screws and nails, and sewing supplies.
- Make a kit of twist ties and plastic bags to take along when you go shopping.
- Save plastic tubs from prepared foods to use as storage containers in the refrigerator and freezer.
- Use plastic jugs from windshield-washer fluid to collect used oil for recycling.
- Reuse scrap paper that's printed on one side. Use the blank side for phone messages or notes.
- Reuse greeting cards by using the front flap as a post card.
- After you've read a magazine, give it to someone else to read, such as friends, nursing homes, hospitals, schools, doctors' waiting rooms or the library.
- Save plastic foam peanuts and other packing materials to use with your next fragile package.
- Save used gift wrap to use again on a smaller package.
- Cut old bedding, drapes and clothes into pieces for rags, or use them in braided rugs or patchwork designs.
- Remove nails and hardware from used lumber so it can be reused in smaller projects. Lumber that is not painted or treated can be safely used for firewood.
- Donate unwanted household items, clothes and appliances that are still usable to charitable organizations. You can also sell them through classified ads, community bulletin boards or garage sales.
- Buy used or remanufactured products and goods when they will do the job as well as new items.

## Use your consumer power

- If the store where you shop doesn't offer returnable containers or products without needless packaging, ask for them. If the items are not provided, tell the store manager you intend to shop somewhere that does offer these items, and do it.
- Write to the manufacturers of products you like and tell them that you'd like these items in returnable, recyclable or less wasteful packaging.

## Reduce waste at work

- Examine the office, production and purchasing procedures where you work to see where wastes can be reduced.
- Offer incentives to workers to come up with new ways to reduce the company's wastes. Establish a quality control program to reduce wastes in your organization.
- Buy equipment that is well built and easily repaired. Maintenance contracts can help extend the life of equipment. Old equipment can be sold or donated to others who can use it.
- Reduce waste paper by circulating and posting memos instead of making copies. Copy documents on both sides of the paper. This will save file space, paper costs and mailing costs while reducing wastes.
- Reuse inter-office envelopes, file folders, boxes and pallets. Scrap paper can be used for notes or donated to schools and day care centers for use in art projects.
- Use convenient send-and-return envelopes for billing. The envelope goes out to the customer, who returns it with payment enclosed.
- Eliminate unnecessary forms, reports and publications to reduce the number that end up being thrown out. Always print or copy double-sided.
- For your cafeteria, parties and company events, buy or rent reusable glassware, table settings, silverware, table linens and serving equipment. Ask caterers to provide these items.

## For more information

To obtain more information about source reduction, contact:

Minnesota Office of Environmental Assistance  
520 Lafayette Rd. N., Second Floor  
Saint Paul, MN 55155-4100  
612-296-3417, or 800-657-3843 toll-free

This fact sheet was prepared by the Minnesota Office of Environmental Assistance with information from Rhode Island Solid Waste Management Corporation and Seattle Engineering Department's Solid Waste Utility.

## Packaging: Reducing waste and cost

Each Minnesotan produces an average of four-and-a-half pounds of garbage every day. Some is being recycled. But the rest must be managed: either by burying it in a landfill, burning it in a waste-to-energy plant or composting it.

About two-thirds of household garbage is packaging from food, cosmetics, toys and other items we buy. One way to reduce trash is to shop with packaging in mind, and look for packaging that creates the least waste.

But what are the alternatives? Which ones generate the least waste?





In 1989, the Minnesota Office of Environmental Assistance (OEA) proved, through a study of commercial sector waste, that it is possible to measure and compare waste and cost between products. The same approach was used in an OEA study of consumer-product packaging. The results show that packaging choices do matter, in terms of both cost and waste.





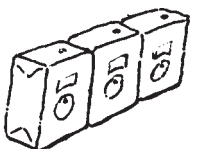

### How the study was done

Researchers began by investigating types of product packaging found in supermarkets. Then they chose 15 grocery-store products with a variety of packaging for measurement. To avoid brand-name bias, they compared different packaging of the same brand, such as raisins in a 1.5-pound bag and the same brand of raisins in snack-size boxes in a bag.

An electronic scale was used to weigh each item both full and empty. Volume was determined by measuring the water displaced when the package, first full and then emptied and crushed in a trash compacter, was submerged in a water-filled cylinder.

The study results reveal that volume and weight vary widely with different packaging, and products with more packaging are usually much more expensive than their less-packaged counterparts.

Waste	
less	more
<b>Glass Cleaner</b>  Liquid pump bottle Less waste, volume: 1239 ml, 61% Less waste, weight: 172 g, 71% Less expensive: \$0.70, 26%	 Pre-moistened wipes
<b>Orange juice</b>  12-oz. can frozen concentrate Less waste, volume: 745 ml, 83% Less waste, weight: 86 g, 74% Less expensive: \$1.33, 55%	 3-pack ready-to-drink boxes
<b>Pre-cut Carrots</b>  Bulk bag Less waste, volume: 194 ml, 89% Less waste, weight: 23 g, 87% Less expensive: \$2.00, 56%	 Pre-packed plastic container



Waste	
less	more
<b>Raisins</b>  1.5-lb plastic bag Less waste, volume: 1108 ml, 97% Less waste, weight: 112 g, 93% Less expensive: \$1.74, 47%	 14 mini-snack boxes in bag
<b>Non-carbonated soft drink</b>  0.13-oz powder packet * Less waste, volume: 2693 ml, 99% Less waste, weight: 218 g, 99% Less expensive: \$2.64, 93%	 6-pack plastic bottles
<b>Chicken Noodle Soup (II)</b>  Condensed can Less waste, volume: 296 ml, 46% Less waste, weight: 42 g, 46% Less expensive: \$2.30, 82%	 Microwave single





Minnesota  
Office of  
Environmental  
Assistance



520 Lafayette Rd. N.  
Second Floor  
St. Paul, MN  
551 55-4100

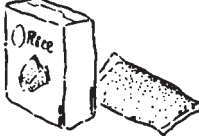

612-296-3417  
Toll Free:  
800-657-3843



	Waste	
	less	more
<b>Pudding</b>		
	5.9-oz. instant box *	Snack 6-pack
	Less waste, volume: 822 ml, 89%	
	Less waste, weight: 47 g, 73%	
	Less expensive: \$1.60, 64%	

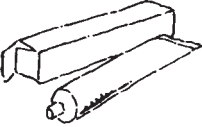

<b>Rice</b>		
	5-lb plastic bag	Boil-in-bag box
	Less waste, volume: 2726 ml, 98%	
	Less waste, weight: 314 g, 96%	
	Less expensive: \$3.75, 47%	



<b>Chicken Noodle Soup</b>		
	Instant single	Microwave single
	Less waste, volume: 211 ml, 98%	
	Less waste, weight: 28 g, 91%	
	Less expensive: \$0.60, 65%	



<b>Frozen Corn</b>		
	28-oz. plastic bag	Single serving 4.5-oz. box
	Less waste, volume: 1006 ml, 98%	
	Less waste, weight: 115 g, 94%	
	Less expensive: \$2.45, 59%	



<b>Toothpaste</b>		
	6.4-oz. tube	4.6-oz. pump
	Less waste, volume: 229 ml, 69%	
	Less waste, weight: 55 g, 58%	
	Less expensive: \$1.00, 36%	



<b>Cereal</b>		
	20-oz. box	3.67-oz. snack box
	Less waste, volume: 1489 ml, 50%	
	Less waste, weight: 174 g, 55%	
	Less expensive: \$2.74, 45%	

<b>Pre-cut Broccoli</b>		
	Bulk bag	Pre-packed plastic container
	Less waste, volume: 194 ml, 89%	
	Less waste, weight: 23 g, 87%	
	Less expensive: \$0.70, 31%	

	Waste	
	less	more
<b>Oats</b>		
	72-oz. bag	12-pack instant box
	Less waste, volume: 1719 ml, 84%	
	Less waste, weight: 303 g, 89%	
	Less expensive: \$10.75, 72%	

<b>Spring Water</b>		
	1-gallon jug	6-pack 12-oz plastic bottles
	Less waste, volume: 4223 ml, 83%	
	Less waste, weight: 310 g, 80%	
	Less expensive: \$4.36, 87%	

<b>Furniture Polish</b>		
	Pump spray bottle	Aerosol can
	Less waste, volume: 176 ml, 29%	
	Less waste, weight: 33 g, 29%	
	Less expensive: \$0.57, 20%	

<b>Milk</b>		
	1-gallon returnable	half gallon cardboard carton
	Less waste, volume: 771 ml, 99%	
	Less waste, weight: 113 g, 95%	
	Less expensive: \$0.11, 4%	

\*Figures do not include cost of additional ingredients added by consumer. All figures are based on an equivalent amount of product. Prices were determined from shelf labels in fall 1991 and will vary slightly according to location and brand. Volume was uniformly compacted and is a conservative estimate of household waste.

To help raise awareness of how consumer choices affect the environment, the Minnesota Office of Environmental Assistance has developed educational materials from the packaging study. These materials are available free of charge.

*For more information on source reduction and waste education contact Ken Brown at 612-215-0241, Jeff Ledermann at 612-215-0236, or 800-657-3843 toll-free.*

# Source-reduced and Reusable Transport Packaging

## *Saving Money and Reducing Waste*

Packaging provides protection for the products we buy, makes handling convenient and displays useful product information. Discarded packaging makes up about one-third of garbage, and packaging waste in the U.S. has more than doubled in 30 years, from 27 million tons in 1960 to 57 million tons in 1988. Retail product packages create about half of all packaging waste. The other half is transport packaging — containers for shipping products from manufacturer to purchaser.

The European Community and Japan generate about one-fourth less packaging waste per person than we do. In the U.S., the consumer bears the cost of packaging disposal. Legislation in Europe places this burden on manufacturers.

However, in both places, manufacturers must pay to buy, ship, store and handle the package. Needlessly heavy or bulky packaging is inefficient, so manufacturers decrease packaging waste to be more competitive. Suppliers are developing new packaging designs and services to meet the demand for source-reduced or reusable, recyclable packaging.

### Packaging guidelines

The Conference of North Eastern Governors (CONEG) developed several initiatives on packaging, including guidelines for packaging design.

- ▶ Eliminate the package whenever possible.

- ▶ Minimize the amount of material in the package.
- ▶ Design packages to be returnable, refillable or reusable.
- ▶ Make packages out of recycled material.

Success stories show that source-reduced packaging decreases waste and cost if product damage does not increase. Reusable packaging works best in “closed-loop” distribution systems.

### “Economic and environmental improvements go hand in hand.”

**Unisys Corp.**’s Roseville facility replaced single-use foam, plastic wrap, paper and cardboard transport packaging with reusable containers — a “kit” containing all assembly components, and use of a computer frame itself as a container for parts. The increase in packaging efficiency saves \$868,000 each year.

**Clow Stamping Co.** manufactures customized shapes for all gauges of sheet metal. Unsatisfied with recycling increasing amounts of container waste, the company bought 380 reusable fiberglass containers to take advantage of a continuous shipping distribution loop coordinated with a supplier. The new containers take less labor, are safer, provide more protection for surfaces, eliminate 24,000 lbs. of waste and save \$14,000 per year.



Minnesota  
Office of  
**Environmental  
Assistance**

520 Lafayette Rd. N.  
Second Floor  
St. Paul, MN  
55155-4100

612-296-3417  
Toll Free:  
800-657-3843



NSC provides computer networking and encryption equipment to a global customer base. Now that a vendor stocks fasteners such as screws, nuts, bolts and washers in refillable bins on a cart on the factory floor instead of supplying them in individualized disposable packaging, NSC saves \$3,050 in decreased material and disposal costs, plus \$3,200 in labor. Adding savings from purchase and disposal costs for all the packaging changes NSC made, the company's new system eliminates more than 65,000 cubic feet or 8,000 pounds of waste and saves \$145,000 each year.

## For more information

Further information and resources about transport packaging and source reduction for businesses are available from the OEA's Education Clearinghouse, 612-215-0232 or 800-877-6300.

## Video

*Transport Packaging: Reducing Waste and Saving Money* is a 12-minute video designed to accompany this fact sheet. It shows examples of packaging efficiency changes made by businesses, and describes their costs of doing so.

**Loan:** Copies are available to borrow for a free, two-week loan and returned for reuse. Call the Clearinghouse at 612-215-0232 to schedule.

**Purchase:** The video is available for purchase by making a out check or money order to the "Minnesota OEA" for \$9.50 and sending it to:

Transport Packaging Video  
Minnesota OEA  
520 Lafayette Rd N 2nd Floor  
Saint Paul MN 55155-4100



## Directory

The OEA's free *Reusable Transport Packaging Directory* lists manufacturers and suppliers of many types of reusable transport packaging. It was developed as a response to increased requests for information on packaging alternatives.



## Fact sheets

Three fact sheets to help businesses recycle common transport packaging wastes — pallets, plastic film and corrugated cardboard — are also available. Each lists markets and common requirements of recycling haulers.

## Steps to make source-reduced and reusable packaging work for you

Efforts to decrease packaging waste and costs work best as part of a company's ongoing quality improvement program. This helps ensure management support, allocation of staff and resources and a structure to inform management about progress.

### 1. Organize a team.

Individuals interested in reducing packaging waste make effective team members, especially people with good communication skills from departments affected by transport packaging changes. Purchasing and marketing staff, in addition to those who handle containers, are important. A facilitator from the team makes sure that progress, assignments and reports are distributed and that communication remains open.

- The team is the link between management and the "packaging handlers" to see that good ideas get support.
- It prioritizes ideas, with those that have the greatest potential for cost savings at the top. However, performance standards must be known first. Employees who unpack materials, truckers, people receiving goods you ship, suppliers and packaging engineers can identify performance needs.
- The team evaluates cost and waste benefits for each packaging change.

### 2. Ask for suggestions.

People who handle packaging will have good ideas about how to reduce it. Make it easy and safe to offer suggestions. The flow of materials into, through and out your facility and assembly line is important to examine.

Questions to ask include:

- Can this package be eliminated? Individually contained products can sometimes be bulked or concentrated.
- Can this package be minimized? Thinner, lighter or less packaging may do the job.
- Is a reusable package an option? A vendor may be able to refill a tray at your facility, or a reusable cart may be able to move a product from a supplier to the assembly floor and out the door.
- Can you use a recyclable package made with recycled content? Even minimized or reusable packages should be recyclable.

Encourage everyone, including forklift and truck drivers, custodial staff and the boss, to put their ideas into suggestion boxes. Signed suggestions allow recognition. Work cell or unit meetings and e-mail are other ways to gather ideas. It is particularly effective when team members write down coworkers' ideas. This also encourages leadership.

Don't forget to ask for ideas outside your facility. Suppliers who participate with you in "Just In Time" delivery systems are often excellent candidates for reusable containers.

### 3. Determine the best type of container.

Many types of source-reduced or durable packaging are available — bags, boxes, bins, totes, pails, drums, racks and pallets. Packaging suppliers will gladly supply samples and information. Reusable containers should stack, nest or collapse for back-hauling; they should wash easily.



Minnesota  
Office of  
**Environmental  
Assistance**

520 Lafayette Rd. N.  
Second Floor  
St. Paul, MN  
55155-4100

612-296-3417  
Toll Free:  
800-657-3843

Whatever the container type and material, it should make handling, emptying and filling easier for everyone. Gather samples.

- ▶ Preliminary cost-benefit information can be obtained at this point to determine which, if any, merit a test run.
- ▶ Some samples may be clear winners; others may require help from a packaging engineer. Source-reduced packaging is effective if product damage does not increase. Reusable packaging requires closed-loop distribution.

#### **4. Test sample containers.**

Walk a sample through its distribution system to see how it works. Write down the opinions of users. Don't expect this to go smoothly, especially if your first effort involves distribution outside the facility. Changes of any kind are rarely accepted without resistance. Use the feedback you get to modify the container or the distribution system to maximize efficiency. Address everyone's concerns before proceeding and keep management informed. If issues are too complex or controversial, choose another suggestion and walk it through its distribution system. Go with the one that works first.

#### **5. Document final changes in cost and waste.**

Keep careful records of cost changes. Staff time decreases for purchasing, stocking, assembling, opening and disposing of single-use containers. Disposal costs go down. Product damage typically decreases. Reuse often improves working relationships in the facility, with suppliers and with the community, as environmental benefits are made known. Write up the issues and benefits, including the payback period.

- Use the most cost-effective container, but stay flexible. A nestable, corrugated *plastic* container may be best for long-term savings, but piloting with a reusable corrugated *cardboard* container may help uncover communication problems unrelated to packaging.

#### **6. Change one package at a time.**

Tests will show which packaging change has the best chance of success. Changing one package at a time allows people to adjust to the "reduce, reuse" principle and lets modifications be made without disrupting productivity.

Announcing the decrease in waste generation helps people understand the environmental effects of their actions. If steps one through four were done well, this process can go smoothly.

#### **7. Establish a feedback method.**

After a packaging change, team members should ask everyone involved — suppliers, assembly line workers, maintenance, truck and fork-lift drivers — for feedback frequently so small problems don't become large ones. Keep management informed. Use staff meetings, newsletters, posters or e-mail to inform employees. Report to local citizen groups. Reward personnel who demonstrate commitment to reduce packaging waste and costs.

#### **Build on your success!**

Once the initial packaging change is in place, proceed with the next one. Depending on complexity, once the first change is done, more than one change may be made at a time.

Improved communication with employees and suppliers may uncover other opportunities for saving! Encourage the team to report these ideas as well, so that economic and environmental benefits continue to thrive in your company.

Reduced and reusable transport packaging does more than protect and move products with less cost and waste. For many companies, it is improving relationships and communication in the warehouse, on the sales or assembly floor, on the road, with vendors and with the community. It can do the same for you.

**If you're  
not  
preventing  
waste,  
you're  
wasting  
resources.**



**Closed minds keep  
dumpsters open.**

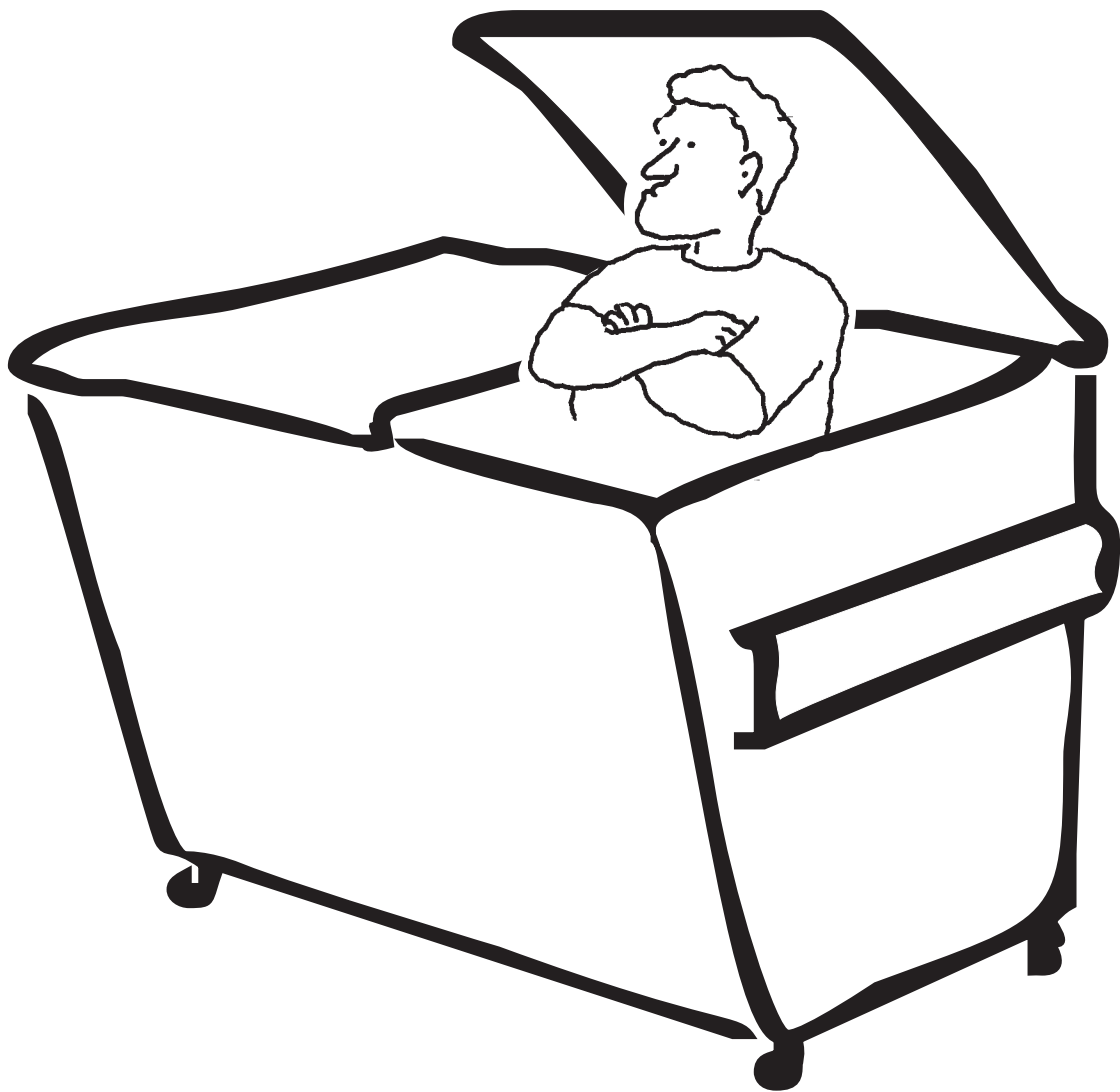

**Two Sides  
are better than  
ONE!**



**Get the same  
amount of copies  
with half the amount  
of paper**

- ★ **No bulk**
- ★ **No Weight**
- ★ **No Waste**

**USE BOTH SIDES!**

— A Reminder from the Solid Waste Reduction Program —

# It pays to repeat yourself.

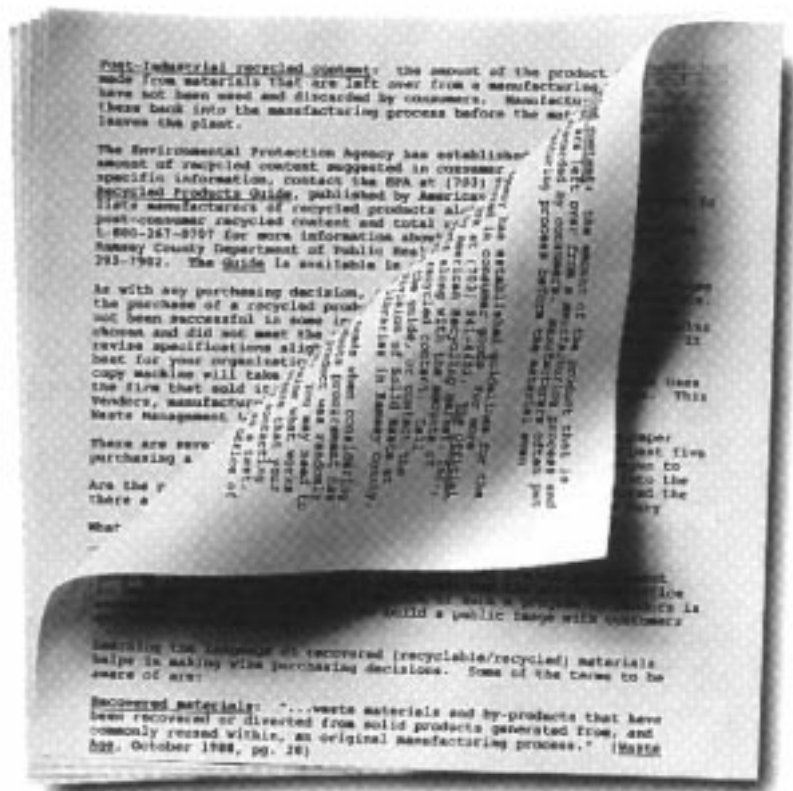

**Some copiers will make double-sided copies automatically, while others have a manual feed slot.**

**Know your copier — and cut paper use in half.**

-  Reduce,
-  reuse, *then*
-  recycle.

# Reusing office supplies is a hot idea.



Use reusable mugs and dinnerware to reduce  
waste and protect the environment.













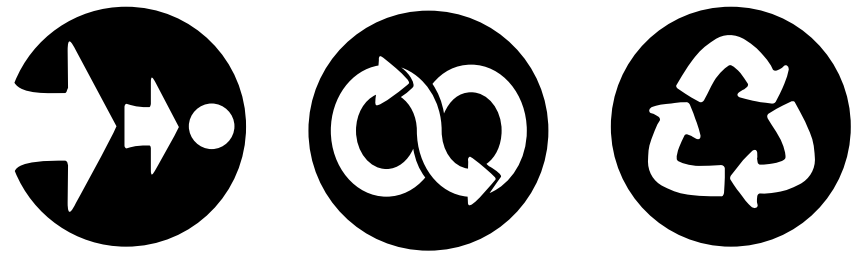









Preventing  
waste  
saves  
money.

 Reduce,  
 reuse, *then*  
 recycle.

 Reduce,  
 reuse, *then*  
 recycle.

    
Reduce Reuse Recycle



          
Reduce Reuse Recycle        
Reduce Reuse Recycle     
Reduce Reuse Recycle

 Reduce,  
 reuse, *then*  
 recycle.

 Reduce,  
 reuse, *then*  
 recycle.

 Reduce,  
 reuse, *then*  
 recycle.